

Spare parts list

WKT 1200

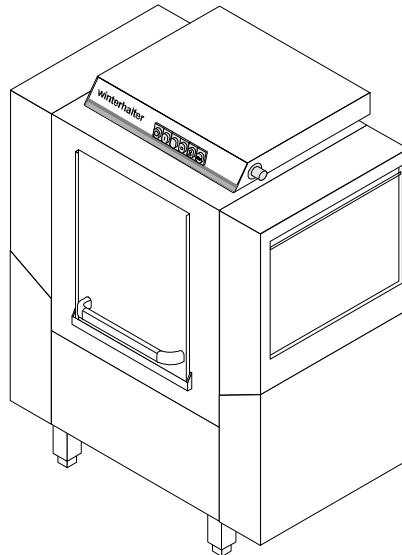

Contents

Water inlet -Standard-	Page 1 - 2
Water inlet (Tundish GB)	Page 3 - 4
Water drainage / Mediamat	Page 5 - 6
Wash pump	Page 7 - 8
Wash system	Page 9 - 10
Pressure boiler	Page 11 - 12
Rinse pump	Page 13 - 14
Pressure-independent boiler	Page 15 - 16
Rinse system	Page 17 - 18
Drive	Page 19 - 20
Rack guide	Page 21 - 22
Chassis, container and panelling	Page 23 - 24
Door	Page 25 - 26
Curtains	Page 27 - 28
Electrical parts I	Page 29 - 30
Electrical parts II up to machine no.: 430 048	Page 31 - 32
Electrical parts II from machine no.: 430 049	Page 33 - 34
Electrical parts III	Page 35 - 36
Steam pipes and steam valves	Page 37 - 38
Steam tank heater	Page 39 - 40
Steam boiler	Page 41 - 42
Condensate conductors	Page 43 - 44

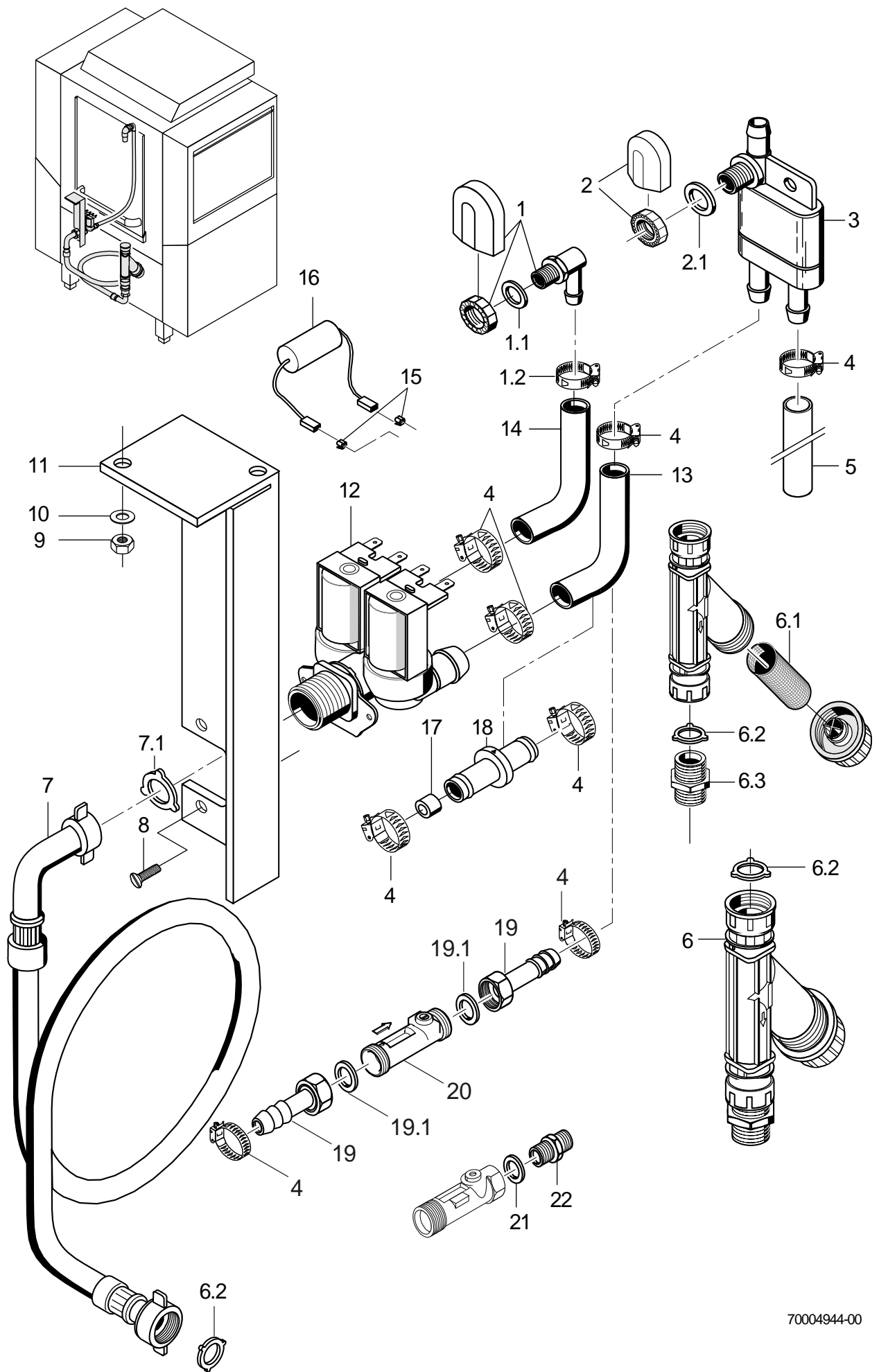

70004944-00

WKT 1200

Water inlet -Standard-

Item.	Designation	Parts no.	Pc.	Notes
1	Water inlet, 3-part set	55 31 007		incl. item 1.1 - 1.2
1.1	O-ring; 20 X 3	27 07 031		
1.2	Hose clamp; D12-22 X 9	30000711		
2	TANK INLET SET	61004545		incl. item 2.1
2.1	Gasket; D17 X D24 X 2,0	62001366		
3	Lateral check valve	35 01 194		
4	Hose clamp; D12-22 X 9	30000711		
5	Industrial hose; DN13 X 3,5	40 02 035		Pressure-independent boiler 1500 mm; Metre item; L-R
5	Industrial hose; DN13 X 3,5	40 02 035		Pressure-independent boiler 2270 mm; Metre item; R-L
5	Hose elbow; DN12,5 X 4,0	40 03 051		Pressure boiler
6	Dirt trap; 150 MICROMETER	80002153		incl. item 6.1 - 6.3
6.1	Strainer; D27 X 67 X 150 MICROMETER	80002728		
6.2	Gasket; D16 X D24 X 3,0	83001022	2	
6.3	DOUBLE NIPPLE; G 3/4" X 40; SW30	80002167		
7	Hose WRC tested; DN13 X 3,5; 2000	40 02 032		incl. item 7.1
7.1	Gasket; D16 X D24 X 3,0	83001022	2	
8	Countersunk screw; M4 X 8	20 10 309		
9	Hexagonal nut; M6	21 05 304		
10	Washer; D6,4 X D12,5 X 1,6	22 01 302		
11	Elbow; 1,5 X 97 X 167	70002418		
12	Double solenoid valve; 220-240V/50-60HZ	31 06 182		
12	Double solenoid valve; 180-220V; 50-60HZ	31 06 200		Japan
13	Industrial hose; DN13 X 3,5	40 02 035		2300 mm; Metre item; L-R
13	Industrial hose; DN13 X 3,5	40 02 035		1200 mm; Metre item; R-L
14	Industrial hose; DN13 X 3,5	40 02 035		1550mm; "By-the-metre" goods
15	Flat plug; 6,3 X 0,8	31 12 018	2	only with Aquamatik; parallel to item 12 connect
16	RC element; 0,15 MICRO F; 3,3 KOHM	31 13 114		only with Aquamatik; parallel to item 12 connect
17	Flow control; 7 L/MIN	31 06 183		with pressure-independent boiler ; not with tundish (UK)
18	Adapter; D9,4 X D13,5 X 54	61004511		with pressure-independent boiler ; not with tundish (UK)
19	Hose coupling; R 3/4" X 1/2"	60002453	2	with pressure boiler and with tundish (UK)
19.1	Gasket; D16 X D24 X 3,0	83001022		
20	Flow regulator; 2 - 8 L/MIN	70011176		with pressure boiler and with tundish (UK)
21	Gasket; D20,9 X D27 X 2,0	27 04 006		
22	Reducing nipple; G 1/2" X G 3/4"; SW27	61003430		

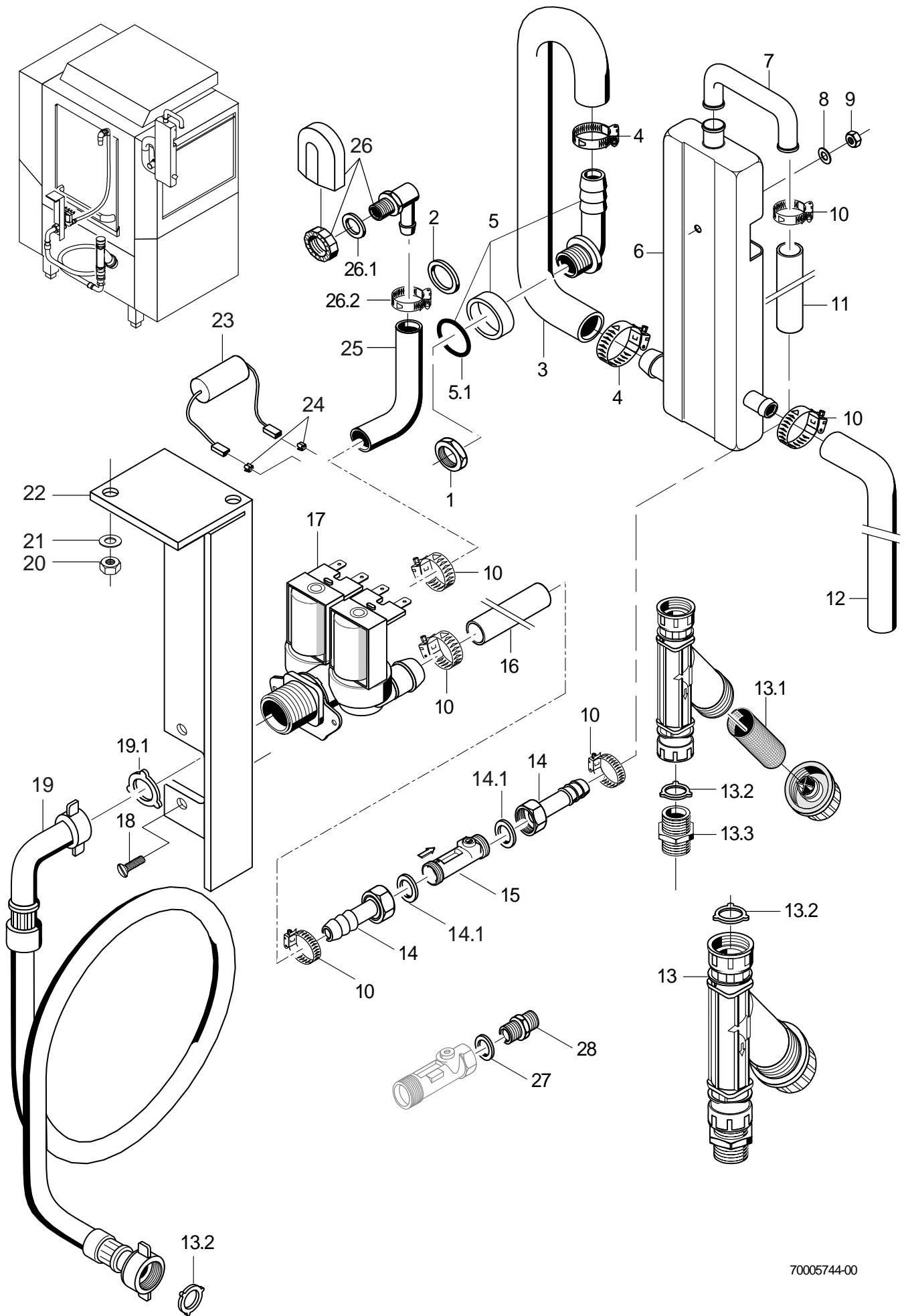

70005744-00

WKT 1200

Water inlet (Tundish GB)

Item.	Designation	Parts no.	Pc.	Notes
1	Hex nut; G 3/4" X 18,0; SW32	30 09 502		
2	Gasket; D26 X D36 X 2,0	27 01 003		
3	Hose bend; DN25 X 4,0	61004322		
4	Hose clamp; D24-44 X 12	28 02 309		
5	Wash distributor cpl.	62002887		adapt
5.1	O-ring; 24 X 3,0	27 07 087	2	
6	Intermediate container; 39 X 131 X 293	60002542		
7	Pipe elbow; DN12 X DN14 X 2,0	60002507		
8	Washer; D5,3 X D10 X 1,0	22 01 300		
9	Hexagonal nut self securing; M5	21 05 302		
10	Hose clamp; D12-22 X 9	30000711		
11	Industrial hose; DN13 X 3,5	40 02 035		2300 mm; "By-the-metre" goods
12	Hose elbow; DN12,5 X 4,0	40 03 051		adapt
13	Dirt trap; 150 MICROMETER	80002153		incl. item 13.1 - 13.3
13.1	Strainer; D27 X 67 X 150 MICROMETER	80002728		
13.2	Gasket; D16 X D24 X 3,0	83001022	2	
13.3	DOUBLE NIPPLE; G 3/4" X 40; SW30	80002167		
14	Hose coupling; R 3/4" X 1/2"	60002453	2	incl. item 14.1
14.1	Gasket; D16 X D24 X 3,0	83001022		
15	Flow regulator; 2 - 8 L/MIN	70011176		
16	Industrial hose; DN13 X 3,5	40 02 035		50 mm; "By-the-metre" goods
17	Double solenoid valve; 220-240V/50-60HZ	31 06 182		
18	Countersunk screw; M4 X 8	20 10 309		
19	WATER SUPPLY HOSE; DN13 X 3,5; 2500	40 02 060		incl. item 19.1
19.1	Gasket; D16 X D24 X 3,0	83001022	2	
20	Hexagonal nut; M6	21 05 304		
21	Washer; D6,4 X D12,5 X 1,6	22 01 302		
22	Elbow; 1,5 X 97 X 167	70002418		
23	RC element; 0,15 MICRO F; 3,3 KOHM	31 13 114		
24	Flat plug; 6,3 X 0,8	31 12 018	2	
25	Industrial hose; DN13 X 3,5	40 02 035		1550mm; "By-the-metre" goods
26	Water inlet, 3-part set	55 31 007		incl. item 26.1 - 26.2
26.1	O-ring; 20 X 3	27 07 031		
26.2	Hose clamp; D12-22 X 9	30000711		
27	Gasket; D20,9 X D27 X 2,0	27 04 006		
28	Reducing nipple; G 1/2" X G 3/4"; SW27	61003430		

WKT 1200

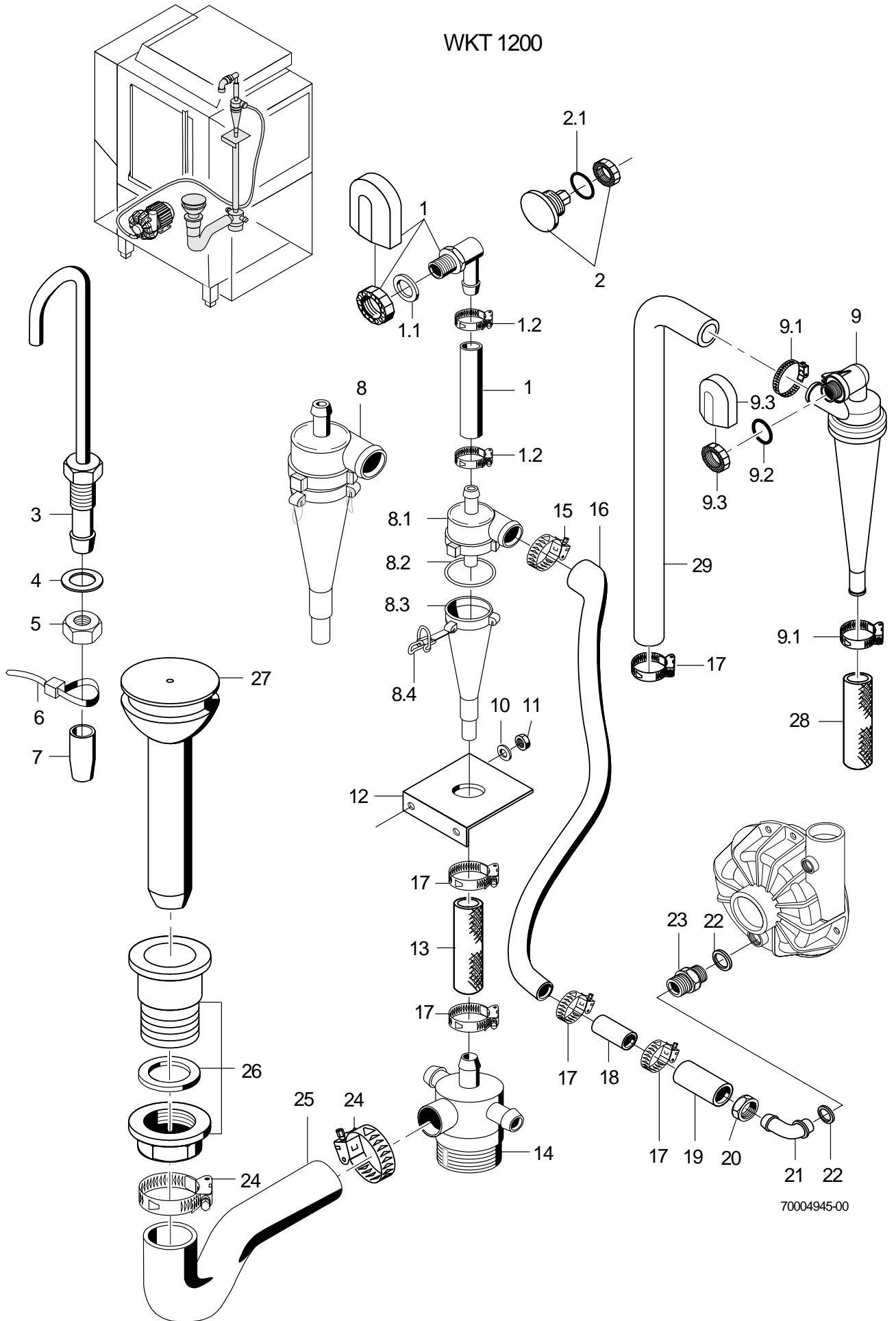

70004945-00

WKT 1200

Water drainage / Mediamat

Item.	Designation	Parts no.	Pc.	Notes
1	Mediamat inlet set cpl.	55 31 001		incl. item 1.1 - 1.2
1.1	Gasket; D20,5 X D28,5 X 2,0	27 01 002		
1.2	Hose clamp; D20-30 X 12	28 02 109	2	
2	Dummy plug; G 1/2" X 21,4;SW10;SW5	70004912		Machine without Mediamat
2.1	O-ring; 20 X 2,5	27 07 004		
3	Dosing nipple	70002494		
4	Gasket; D8 X D15 X 1,5	27 09 001		
5	Hexagonal nut; M8	21 01 305		
6	Cable tie; 100 X 2,5	31 20 175		
7	End cap; D5,7 X 25,4	35 06 180		
8	Mediamat	55 27 040		incl. item 8.1 - 8.4 up to mach. no.: 477 033
8.1	Mediamat top section; ZULAUF D30; XX LG	35 01 124		
8.2	O-ring; 51 X 3	27 07 043		
8.3	Accelerator; D75 X 169 X D4,3	35 01 035		
8.4	Wash arm end piece clip; D2,0	28 04 041	4	
9	Mediamat Cyclo	61005184		from machine no.: 477 034
9.1	Hose clamp; D12-22 X 9	30000711	2	
9.2	O-ring; 20 X 3,5	27 07 040		
9.3	Tank inlet set; G 1/2" X 8; SW27	61005339		
10	Washer; D5,3 X D12 X 0,8	22 02 313		up to machine no.: 477 033
11	Hexagonal nut self securing; M5	21 05 302		up to machine no.: 477 033
12	Support for mediamat; 1,5 X 50 X 75	61000658		up to machine no.: 477 033
13	Industrial hose; DN19,4 X 3,5	40 01 016		R-L 880 mm; "By-the-metre" goods
13	Industrial hose; DN19,4 X 3,5	40 01 016		L-R 650 mm; "By-the-metre" goods
14	Mediamat drain; G 1 1/2"; D40	35 01 080		
15	Hose clamp; D32-52 X 12	28 02 110		up to machine no.: 477 033
16	Reducing hose; DN16 X DN30; 1300	40 03 036		up to machine no.: 477 033
17	Hose clamp; D20-30 X 12	28 02 306		
18				L-R 50 mm "By-the-metre" goods 0220027
19	Reducing hose; DN16 X DN30; 1300	40 03 036		L-R
20	Coupling nut; G 3/4" X D20,5; SW30	29 07 203		
21	Mediamat connection elbow; D17; 90GRAD	29 06 524		
22	Gasket; D19,5 X D24 X 1,5	27 09 010	2	
23	Mediamat connection nipple; G 1/2" X G 3/4" X 32	30 11 502		
24	Hose clamp; D32-52 X 12	28 02 110		
25	Reducing elbow; DN37 X DN40	40 03 022		
26	Stand pipe bottom part; G 1 1/2"; D70 X 55	29 04 224		
27	Standpipe; ÜBERLAUFHÖHE 334; D40	70002114		
28	Industrial hose; DN16 X 4,0	40 01 015		from machine no.: 477 034; 980 mm; "By-the-metre" goods
29	Moulded hose; DN15 X 4; 90 Grad; 1637	70005415		from machine no.: 477 034

WKT 1200

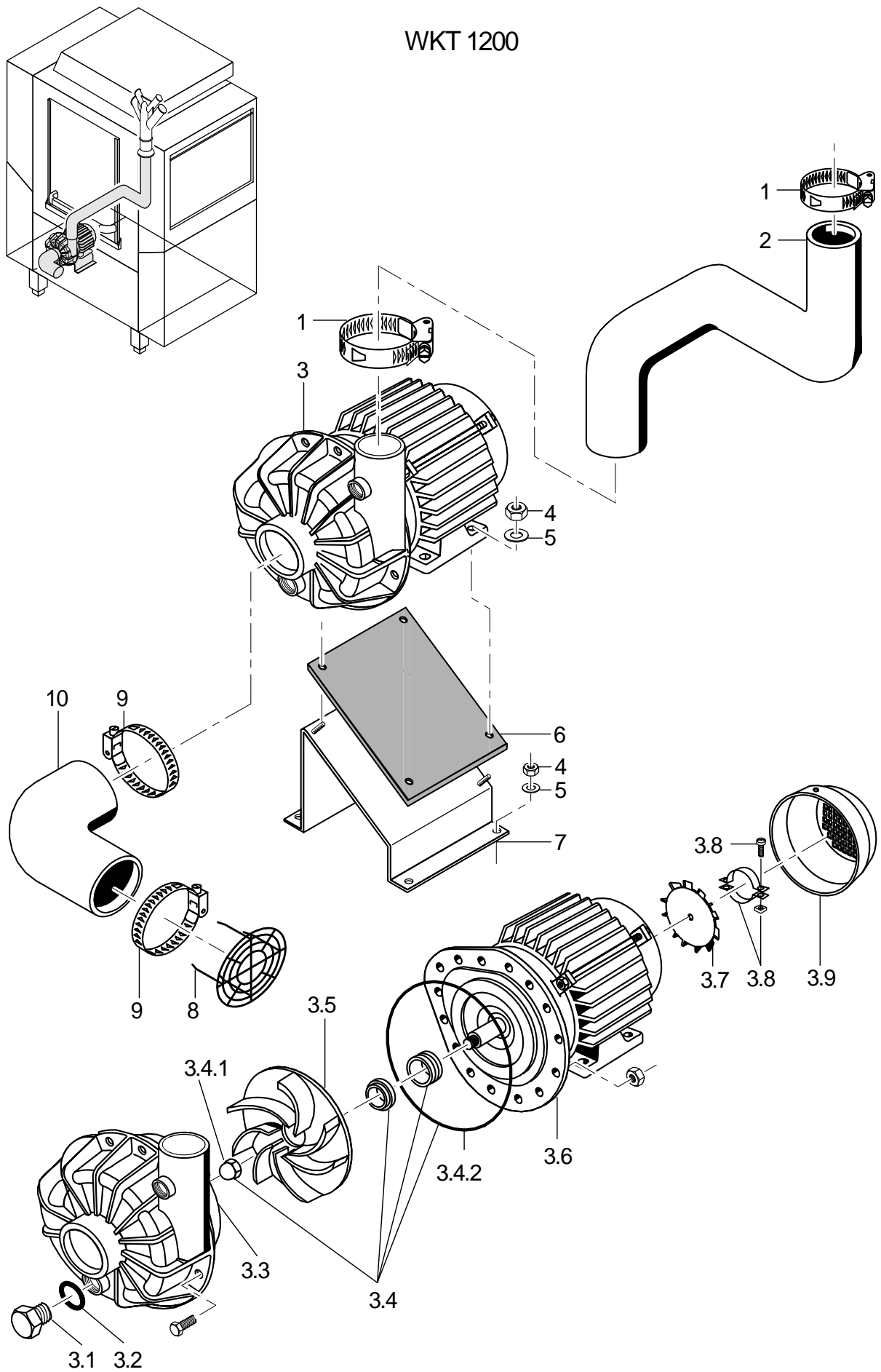

70004946-00

WKT 1200

Wash pump

Item.	Designation	Parts no.	Pc.	Notes
1	Hose clamp; D50-70 x 12	30001243		
2	Hose elbow; DN50 X 6,0	70002581		L-R
2	Hose elbow; DN50 X 6,0	70002580		R-L
3	Pump 1.1 kW 9/1; 230V/400V/3/50HZ; IP44	31 02 411		incl. item 3.1 - 3.9
3	Pump 1.1 kW; 230V/400V/3/60HZ; IP44	31 02 412		
3	; 200V/346V/3/50HZ; IP44	31 02 556		
3	; 200V/346V/3/60HZ; IP44	31 02 554		
3	Pump 1.1 kW 9/1; 254V/440V/3/60HZ; IP44	31 02 416		
3.1	Dummy plug; G 1/2" X 20,5	35 01 108		
3.2	O-ring; 20 X 3,5	27 07 040		
3.3	Pump housing	31 02 204		
3.4	Gasket set; 1,1/1,7/1,85/0,73 KW	80002670		incl. item 3.4.1, 3.4.2
3.4.1	Dome head nut; M8	21 10 305		
3.4.2	O-ring; 158,35 X 3,53	31 02 209		
3.5	Pump impeller; D111	31 02 273		50 Hz
3.5	Pump impeller; D96	31 02 274		60 Hz
3.6	Pump cover	31 02 208		
3.7	Fan blade	31 02 211		
3.8	Fixing clamp	31 02 218		
3.9	Fan cover	31 02 212		
4	Hexagonal nut; M6	21 05 304		
5	Washer; D6,4 X D12,5 X 1,6	22 01 302		
6	Rubber base; 3,0 X 130 X 155	71000283		
7	Support	70002068		
8	Suction sieve; D72	62001956		
9	Hose clamp; 70 - 90MM / 12MM	30002614		
10	Hose elbow 90°; DN62X9,0;80X180	40 03 028		

WKT 1200

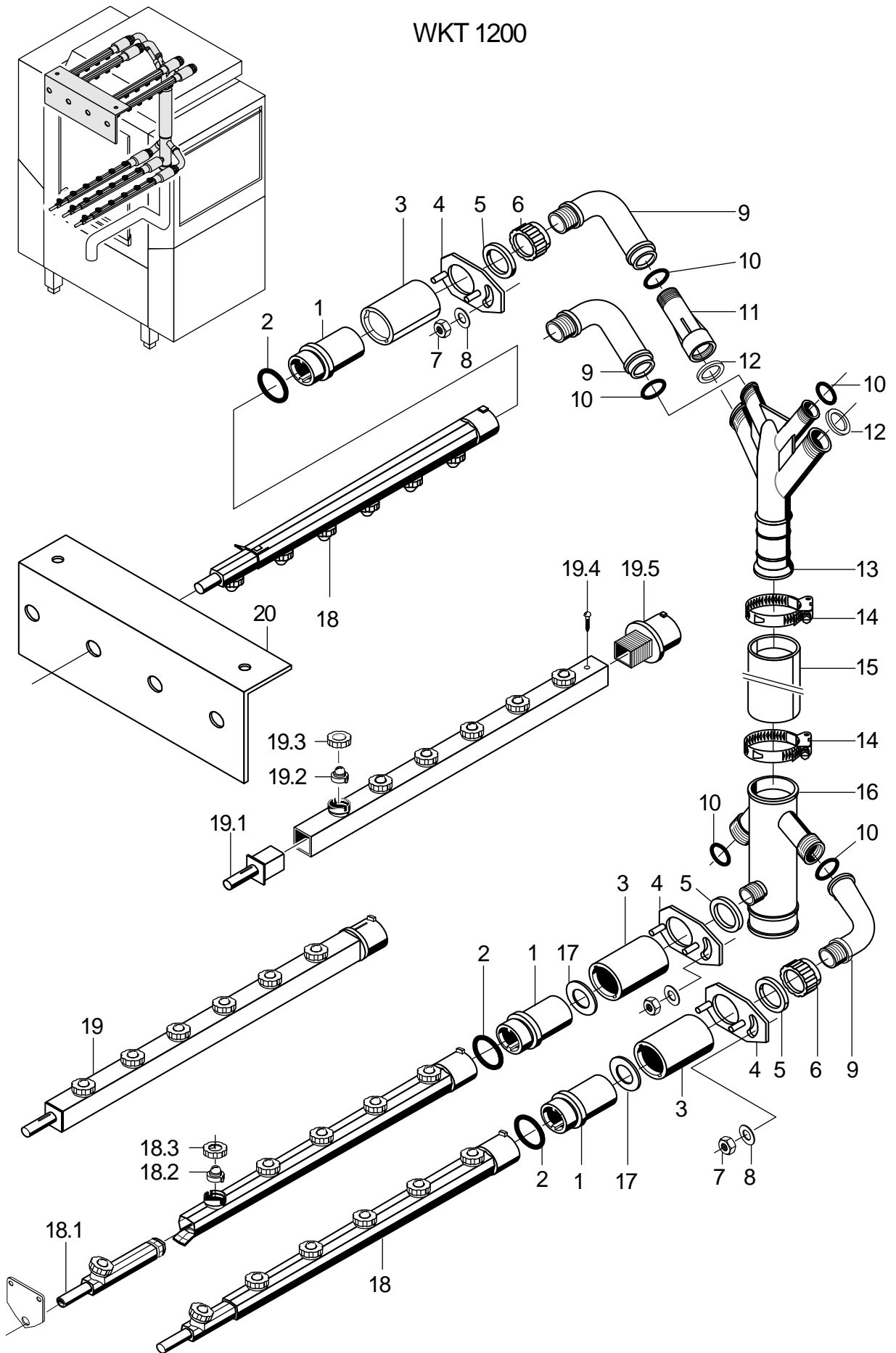

70004947-00

WKT 1200

Wash system

Item.	Designation	Parts no.	Pc.	Notes
1	Locking nut; D38 X 69,5; G 3/4"	61004060	7	
o.P.	Locking nut; D38 X 53; G 3/4"	61004061	7	with wash arm metal
2	O-ring; 28 X 2,5	27 07 049	7	
3	Locking ring 70 mm; D49 X 68,5	70002095	7	
o.P.	Locking nut; D49 X 51,5	72001074	7	with wash arm metal
4	Fixing ring; 1,5 X 50 X 70	70002092	7	
o.P.	Fixing ring; 1,5 X 50 X 70	65003529	7	with wash arm metal
5	Gasket; D26 X D36 X 2,0	27 01 003	6	
6	Coupling nut; G 1 1/4" X 24	35 01 004	6	
7	Hexagonal nut self securing; M4	21 05 300		
8	Washer; D4,3 X D12 X 1,0	22 05 300		
9	Manifold elbow short; G 3/4"; 51 X 76	35 01 150	6	
10	O-ring; 24 X 3,0	27 07 087	6	
11	Extension; G 1 1/4" X 131	35 01 003	2	
12	Gasket; D30 X D39 X 2,0	27 02 001	2	
13	Wash manifold top section	35 01 017		
14	Hose clamp; D50-70 x 12	30001243		
15	Industrial hose; DN50 X 6,0	40 02 006		90 mm; "By-the-metre" goods
16	Wash manifold bottom section	35 01 018		
17	Washer; D10 X D24 X 1,5	62002653		Japan
18	Wash arm cpl.; 6 DÜSEN; 132,5 LG	70002382	7	incl. item 18.1 - 18.3
18.1	End piece - sloping; 1DÜSE; 117 LG	61002084		
18.2	Slotted jet; D20,5 X 14	70002104	6	
18.3	Coupling nut; G 3/4" X D16	62001808	6	
19	Wash arm cpl.; 6 DÜSEN; 489 LG	70002295		Option incl. item 19.1 - 19.5
19.1	Guide piece; 30 X 30 X 73,5	65002080		
19.2	Slotted jet; D20,5 X 14	70002104	6	
19.3	Coupling nut; G 3/4" X D16	62001808	6	
19.4	Sheet metal screw; ST 2,9 X 6,5	20 20 308		
19.5	Wash arm head; D44 X 69	65002079		
20	Bracket; 1,5 X 129,5 X 530	70002436		
21	O-ring; 28 X 2,5	27 07 049		

WKT 1200

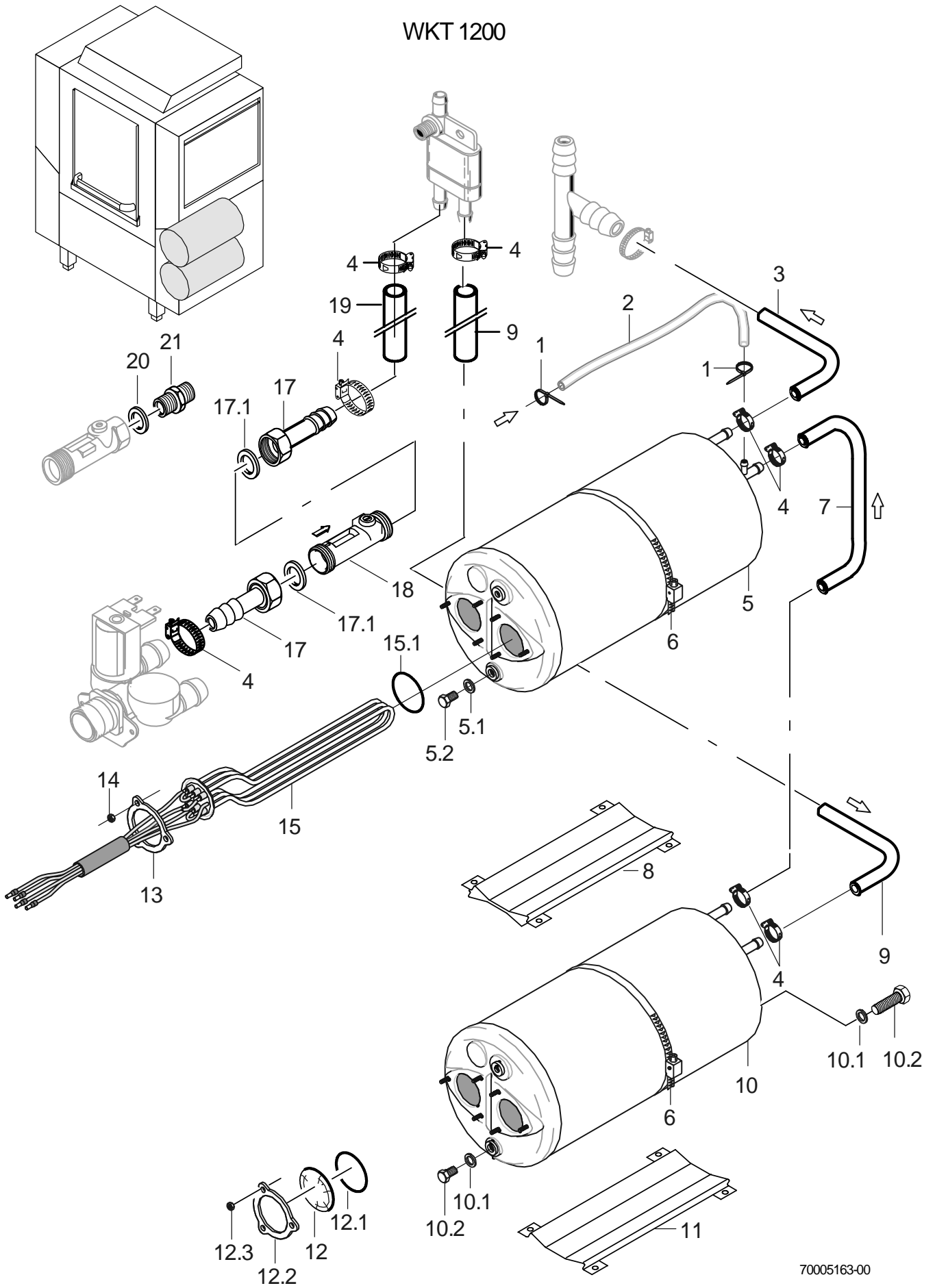

70005163-00

WKT 1200

Pressure boiler

Item.	Designation	Parts no.	Pc.	Notes
1	Cable tie; 100 X 2,5	31 20 175		
2	Hose; DN5 X 1,5	40 01 024		1000 mm; "By-the-metre" goods
3	Hose bend; DN12,5 X 4,0	40 03 050		
4	Hose clamp; D12-22 X 9	30000711		
5	Boiler compl.	61005192		incl. item 5.1 – 5.2
5.1	Hexagon screw; M10 X 16; A70	20 01 352		
5.2	Gasket; D10 X D18 X 1,5	27 03 003		
6	Hose clamp; D50-215 X 12	28 02 126		
7	Shaped; DN12,5 X 4,0	70005118		
8	Boiler profile; 31 X 126,6 X 300	70005119		
9	Hose elbow; DN12,5 X 4,0	40 03 051		
10	Boiler compl.	61005819		incl. item 10.1 - 10.2
10.1	Hexagon screw; M10 X 16; A70	20 01 352		
10.2	Gasket; D10 X D18 X 1,5	27 03 003		
11	Boiler profile; 1,5 X 155,3 X 300	70005003		
12	Blind flange	60002787		incl. item 12.1 - 12.3
12.1	O-ring; 43 X 7,0	27 07 088		
12.2	Locking washer; D43 X D80 X 4,0	01 17 003		
12.3	Hexagonal nut; M5	21 01 203		
13	Locking washer; D43 X D80 X 4,0	01 17 003		
14	Hexagonal nut; M5	21 01 203		
15	Heating element, boiler 6.0 kW with fuse; 400-440V, 3~, 6KW	30008044		
15	Heating element, boiler 6.0 kW with fuse; 400-440V, 3~, 6KW	30008045		Australia
15	Heating element, boiler 6.0 kW with fuse; 230V, 3~, 6KW	30008050		
15	Heating element, boiler 6.0 kW with fuse; 200V, 3~, 6KW	30008046		
15.1	O-ring; 43 X 7,0	27 07 088		
17	Hose coupling; R 3/4" X 1/2"	60002453		incl. item 17.1
17.1	Gasket; D16 X D24 X 3,0	83001022		
18	Flow regulator; 2 - 8 L/MIN	70011176		
19	Industrial hose; DN13 X 3,5	40 02 035		2300 mm; "By-the-metre" goods
20	Gasket; D20,9 X D27 X 2,0	27 04 006		
21	Reducing nipple; G 1/2" X G 3/4"; SW27	61003430		
o.P.	Conversion to pressurised boiler	55 28 276		w/o heating elements

WKT 1200

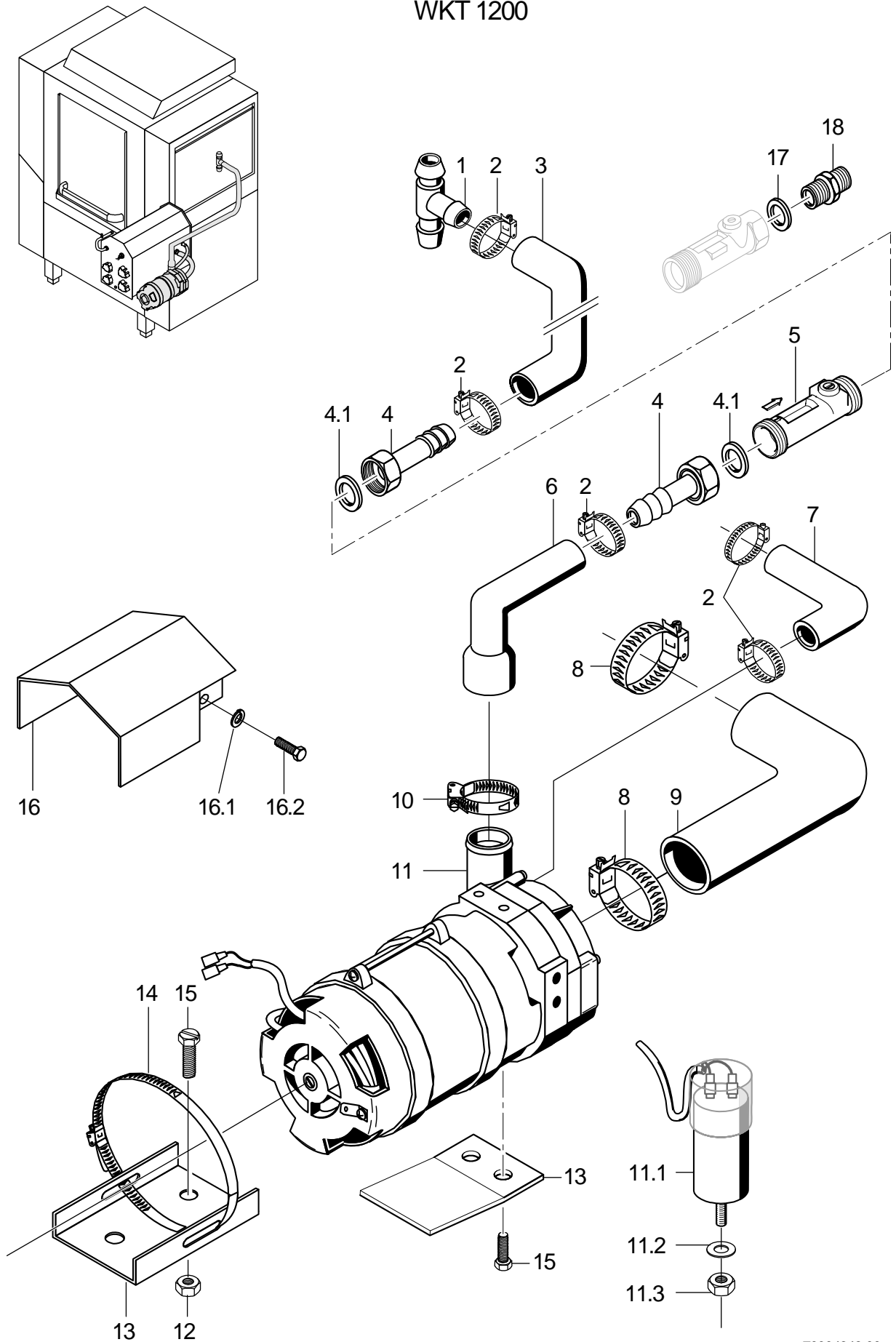

70004949-00

WKT 1200

Rinse pump

Item.	Designation	Parts no.	Pc.	Notes
1	Hose T-connecting piece; D15 X D15 X D15	70010598		
2	Hose clamp; D12-22 X 9	30000711		
3	Industrial hose; DN13 X 3,5	40 02 035		L-R 850 mm; "By-the-metre" goods
3	Industrial hose; DN13 X 3,5	40 02 035		R-L 2000 mm; "By-the-metre" goods
4	Hose coupling; R 3/4" X 1/2"	60002453	2	incl. item 4.1
4.1	Gasket; D16 X D24 X 3,0	83001022		
5	Flow regulator; 2 - 8 L/MIN	70011176		
6	Reducing elbow; DN13 X DN25	62002145		adapt
7	Reducing elbow; DN10 X DN14	40 03 003		
8	Hose clamp; D32-52 X 12	28 02 110		
9	Hose elbow 90°; DN25X4,0;80X130	80001902		
10	Hose clamp; 25 - 40MM / 12MM	30002612		
11	Pump 0.270 kW 8/0; 220/240V/1/50HZ	31 02 477		incl. item 11.1 - 11.3
11	Pump 0.270 kW 8/0; 220/240V/1/60HZ	31 02 445		incl. item 11.1 - 11.3
11	Pump 0.270 kW 8/0; 200V/1/50HZ	31 02 446		incl. item 11.1 - 11.3
11	Pump 0.270 kW 8/0; 200V/1/60HZ	31 02 447		incl. item 11.1 - 11.3
11.1	Capacitor; 5 MIKRO F	31 13 099		
11.2	Spring washer; B8	23 03 301		
11.3	Hexagonal nut; M8	21 01 305		
12	Hexagonal nut; M6	21 01 304		up to machine no.: 470 078
13	Pump bracket; 2,0 X 60 X 70	80001407		up to machine no.: 470 078
13	Support; 2,0 X 45 X 75,5	70005288		from machine no.: 470 079
14	Hose clamp; D90-110 X 12	30002084		up to machine no.: 470 078
15	Hexagon screw; M6 X 16; A70	20 01 306		
16	Guard plate	80002255		incl. item 16.1 – 16.2
16.1	Spring washer; B6	23 03 300		
16.2	Hexagon screw; M6 X 16; A70	20 01 306		
17	Gasket; D20,9 X D27 X 2,0	27 04 006		
18	Reducing nipple; G 1/2" X G 3/4"; SW27	61003430		
o.P.	Conversion to pressurised boiler	55 28 276		w/o heating elements

WKT 1200

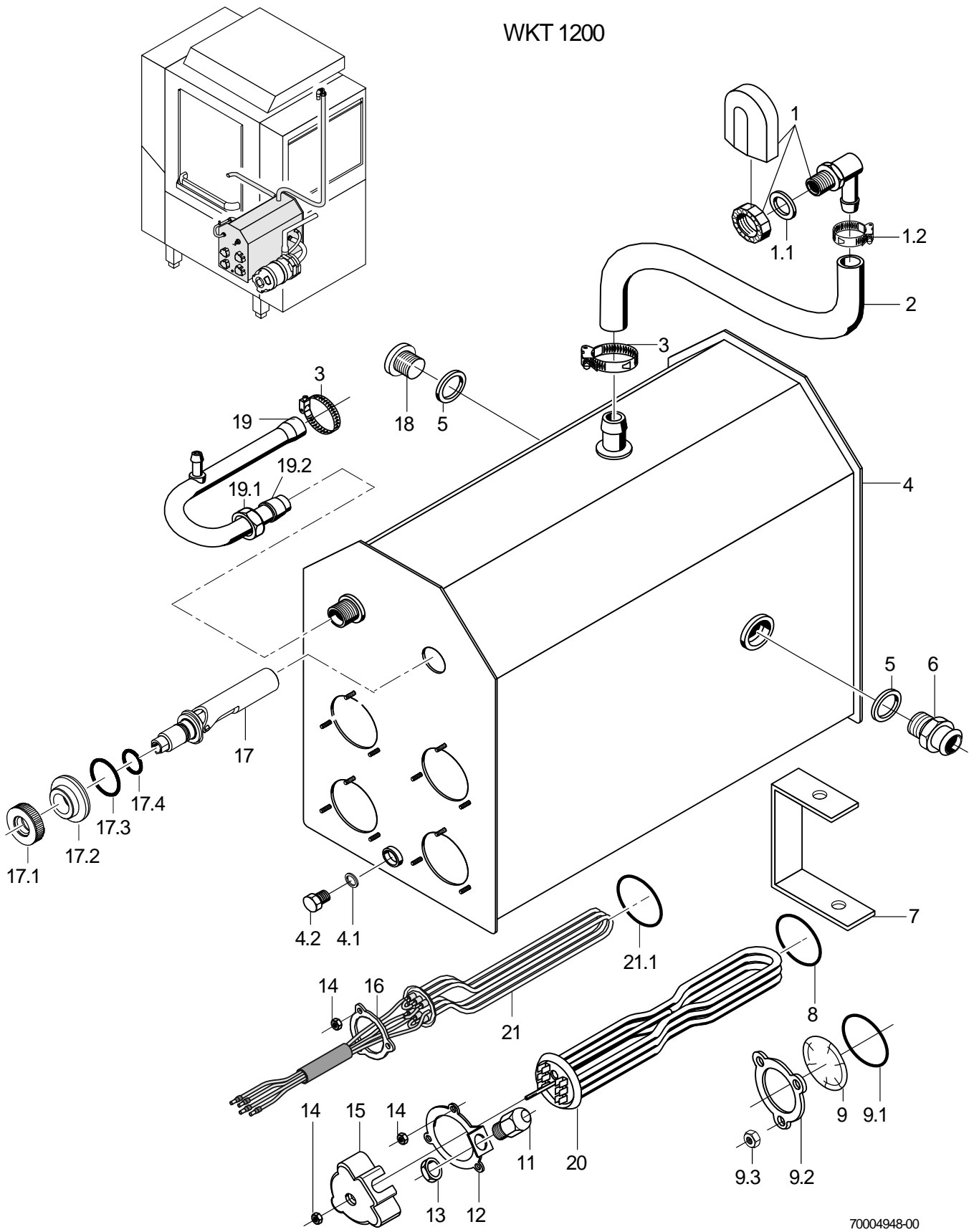

70004948-00

WKT 1200

Pressure-independent boiler

Item.	Designation	Parts no.	Pc.	Notes
1	Water inlet, 3-part set	55 31 007		incl. item 1.1 - 1.2
1.1	Gasket; D20,5 X D28,5 X 2,0	27 01 002		
1.2	Hose clamp; D12-22 X 9	30000711		
2	Hose bend; DN12,5 X 4,0	40 03 050		
3	Hose clamp; D12-22 X 9	30000711		
4	Boiler 4-holes; 484,25 LG	70002387		incl. item 4.1 - 4.2
4.1	Hexagon screw; M10 X 16; A70	20 01 352		
4.2	Gasket; D10 X D18 X 1,5	27 03 003		
5	Gasket; D13,3 X D18 X 2,0	27 09 012		
6	Hose nipple; D26 X 41; G 1/2"; SW27	80001403		
7	Bracket; 1,5 X 20 X 100	65003523		
8	O-ring; 43 X 7,0	27 07 088		
9	Blind flange	60002787		incl. item 9.1 – 9.3
9.1	O-ring; 43 X 7,0	27 07 088		
9.2	Locking washer; D43 X D80 X 4,0	01 17 003		
9.3	Hexagonal nut; M5	21 01 203		
11	Cable gland PG13.5; PG13,5; 6-12 MM; IP68	31 10 040	4	up to machine no.: 430 047
12	Clamping plate; D43 X D80 X 4,0	55 19 018	4	up to machine no.: 430 047
13	Hexagonal nut; PG13,5	31 10 041	4	up to machine no.: 430 047
14	Hexagonal nut; M5	21 01 203		
15	Element cover; 50 X D67 X 89,5	31 03 014	4	up to machine no.: 430 047
16	Locking washer; D43 X D80 X 4,0	01 17 003		from machine no.: 430 048
17	Floating switch installation set	55 28 255		incl. item 17.1 - 17.4
17.1	Nut; M14 X 2, D26,8 X 8	60003989		
17.2	Ring; D14,3 X D32 X 11	60003872		
17.3	O-ring; 24 X 3,0	27 07 087		
17.4	O-ring; 11,11 X 1,78	27 07 079		
18	Screw plug; G 1/2"	30 08 303		
19	Boiler inlet elbow, cpl.	55 09 054		incl. item 19.1 – 19.2
19.1	Coupling nut; G 1/2" X D12,2; SW24	29 07 201		
19.2	Cutting ring; D12 X 10	29 07 300		
20	Heating element cranked 9,0kW; 230V/400V/3	31 03 018		up to machine no.: 430 047
20	Heating element cranked 6.0kW; 230V/400V/3	31 03 017		up to machine no.: 430 047
20	Heating element cranked 9,0kW; 240V/420V/3	31 03 057		up to machine no.: 430 047
20	Heating element cranked 6.0kW; 240V/420V/3	31 03 043		up to machine no.: 430 047
20	Heating element cranked 6.0kW; 200V/346V/3	31 03 046		up to machine no.: 430 047
21	Heating element, boiler 6.0 kW with fuse; 400-440V, 3~, 6KW	30008044		from machine no.: 430 048
21	Heating element, boiler 6.0 kW with fuse; 400-440V, 3~, 6KW	30008045		Australia
21	Heating element, boiler 6.0 kW with fuse; 230V, 3~, 6KW	30008050		from machine no.: 430 048
21	Heating element, boiler 6.0 kW with fuse; 200V, 3~, 6KW	30008046		from machine no.: 430 048
21.1	O-ring; 43 X 7,0	27 07 088		
o.P.	Conversion to pressurised boiler	55 28 276		w/o heating elements

WKT 1200

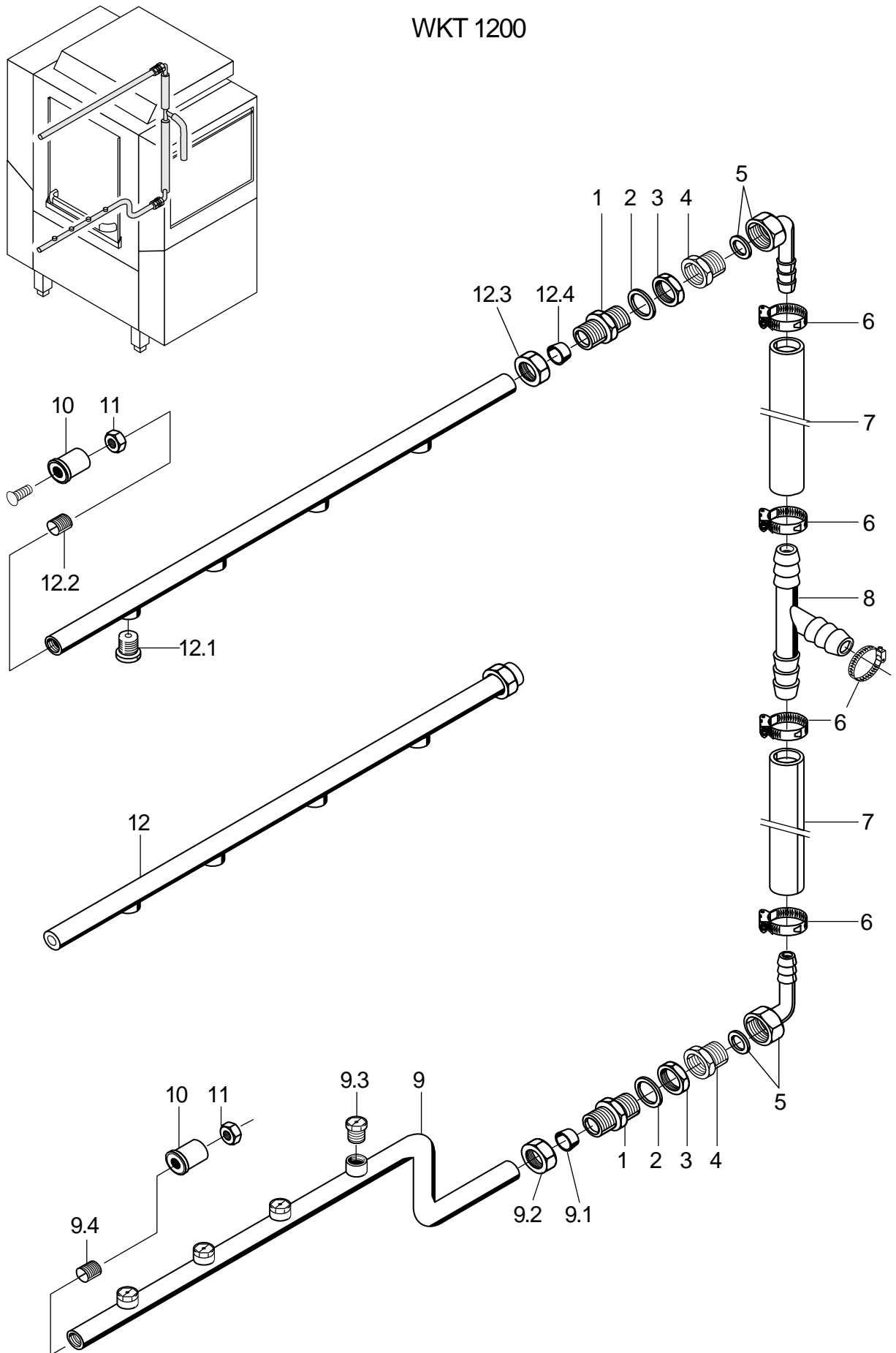

70004950-00

WKT 1200

Rinse system

Item.	Designation	Parts no.	Pc.	Notes
1	Double nipple; G 1/2" X 38; SW27	30 11 301	2	
2	Gasket; D21 X D28 X 2,0	27 09 011	2	
3	Hexagonal nut; G 1/2" X 8,0; SW27	30 09 201	2	
4	Reducing nipple; G 1/2" X G 3/4"; SW30	70004851	2	from machine no.: 391 605
5	Set elbow screwing	55 28 249	2	up to machine no.: 391 604
5	Hose nipple, angled; D18	60002474	2	from machine no.: 391 605
6	Hose clamp; D12-22 X 9	30000711	5	
7	Industrial hose; DN13 X 3,5	40 02 035		300 mm; "By-the-metre" goods
8	Hose T-connecting piece; D15 X D15 X D15	70010598		
9	Rinse pipe cpl.; 4 DÜSEN, 623 LG	70003338		incl. item 9.1 - 9.4
9.1	Cutting ring; D12 X 10	29 07 300	2	
9.2	Coupling nut; G 1/2" X D12,2; SW24	29 07 301	2	
9.3	Flat rinse jet; 1/16 NPT; SW10;GR.5-90	29 10 313	4	
9.4	Threaded pin; M11 X 1,0 X 20	20 30 503		
10	Bushing; D28 X 30	61002343	2	
11	Hexagonal nut; M6	21 05 304		
12	Rinse pipe cpl.; 4 DÜSEN, 623 LG	70003337		incl. item 12.1 - 12.4
12.1	Flat rinse jet; 1/16 NPT; SW10;GR.5-90	29 10 313	4	
12.2	Threaded pin; M11 X 1,0 X 20	20 30 503		
12.3	Coupling nut; G 1/2" X D12,2; SW24	29 07 301	2	
12.4	Cutting ring; D12 X 10	29 07 300	2	

WKT 1200

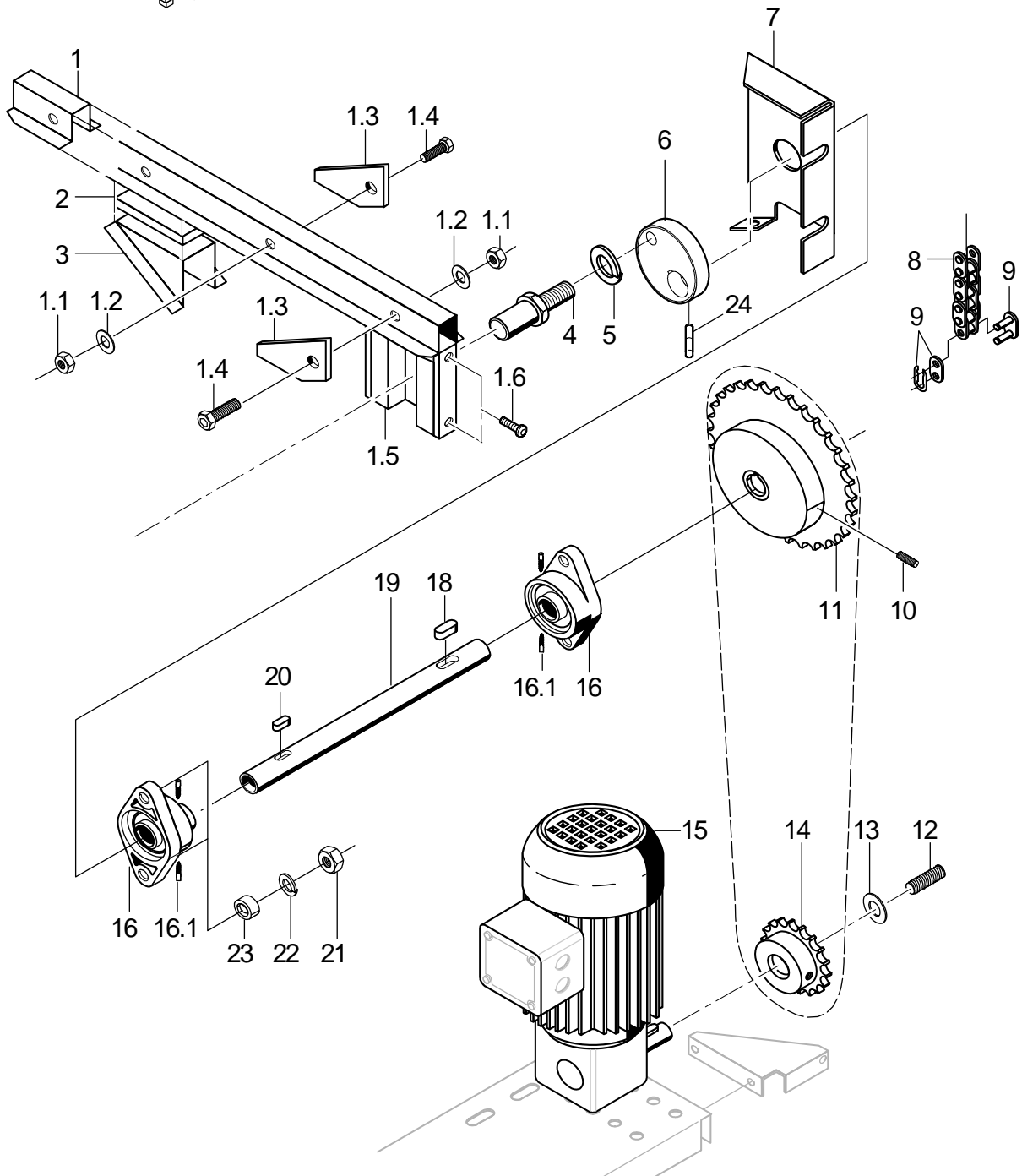
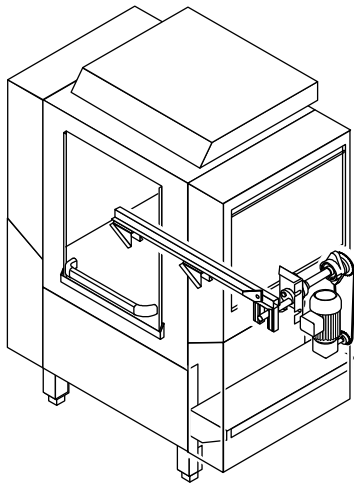

70004951-00

WKT 1200

Drive

Item.	Designation	Parts no.	Pc.	Notes
1	Connecting rod cpl. L-R; 1173 LG	70002556		incl. item 1.1 - 1.6
1	Connecting rod cpl. R-L; 1173 LG	70002558		
1.1	Hexagonal nut; M6	21 05 304	7	
1.2	Washer; D8,5 X D17 X 1,0	22 08 515	7	
1.3	Ratchet; 4,0 X 48 X 67	55 16 069	7	
1.4	Screw for connecting rod; M6 X 28,8; D12	70000205	7	
1.5	CF-profile; 14 X 20 X 98	70002538	2	up to machine no.: 441 427
1.5	Sliding piece; 16,8 X 20 X 98	70005164		from machine no.: 441 428
1.6	PT screw; KB 50 X 16	20 17 301	4	
2	Sliding rail; 14 X 20	70002574		60 mm; "By-the-metre" goods
3	Support	70002405	2	
4	Bolt; SW17 X 53	70002547		
5	Spring ring; A10	23 03 303		
6	Eccentric cam; D60 X 20; HUB 70	70002432		
7	Support	70002422		
8	Roller chain; 3/8" X 7/32"	28 10 038		1200 mm; "By-the-metre" goods
9	Master link; 06 B-1	28 10 037		
10	Grub screw; M6 X 16	20 30 302		
11	Chain wheel 22 teeth; 3/8" X 7/32" X 28	70002434		racks/hr: 100/155 frequency: 50 Hz
11	Chain wheel 24 teeth; 3/8" X 7/32" X 28	70002577		up to mach. no. 401 951; racks/hr: 60/120; frequency: 50 Hz
11	Chain wheel 27 teeth; 3/8" X 7/32" X 28	70003174		racks/hr: 100/155 frequency: 60 Hz
11	Chain wheel 32 teeth; 3/8" X 7/32" X 30	65003750		racks/hr: 70/110; frequency: 50 Hz
11	Chain wheel 38 teeth; 3/8" X 7/32" X 30	70002825		racks/hr: 70/110; frequency: 60 Hz
12	Grub screw; M6 X 16	20 30 302		
13	Washer; D8,4 X D17 X 1,6	22 01 303		
14	Chain wheel 16teeth; 3/8" X 7/32" X 28	65003268		up to machine no.: 401 951
14	Chain wheel 18 teeth; 3/8" X 7/32" X 28	70002576		up to machine no.: 401 951
14	Chain wheel with clutch; 3/8" X 7/32"	28 10 005		from machine no.: 401 952
15	Geared motor 0,12/0,18kW; 380-440V/3/50HZ	31 16 035		50 Hz up to machine no.: 401 951
15	Geared motor 0,12/0,18kW; 380-440V/3/50HZ-60HZ	31 16 014		60 Hz up to machine no.: 401 951
15	Geared motor 0,12/0,18kW; 230V/3/50HZ	31 16 026		up to machine no.: 401 951
15	Geared motor 0,12/0,18kW; 230V/3/60HZ	31 16 065		up to machine no.: 401 951
15	Geared motor 0,12/0,18kW; 200V/3/50HZ-60HZ	31 16 067		up to machine no.: 401 951
15	Gear motor; 380V-440V/3/50-60HZ	31 16 070		from machine no.: 401 952
15	Gear motor; 220-230V/3/50-60HZ	31 16 072		from machine no.: 401 952
15	Gear motor; 200V/3/50-60HZ	31 16 071		from machine no.: 401 952
16	Kit bearing with housing	70011769	2	incl. item 16.1
16.1	Grub screw; M6 X 8	20 30 304	2	
18	Parallel key; A6 X 6 X 25	70002435		
19	Shaft; D20 X 345	70002431		up to machine no.: 401 951
19	Shaft; D20 X 350	70002822		from machine no.: 401 952
20	Parallel key; A6 X 6 X 20	26 10 300		
21	Hexagonal nut; M8	30002585		
22	Spring washer; B8	23 03 301		
23	Pipe; D10 X 0,75 X 10	70200405	4	
24	Grub screw; M6 X 8	20 30 304		

WKT 1200

Rack guide

Item.	Designation	Parts no.	Pc.	Notes
1	Covering plate; 1,25 X 150 X 251,5	70004909		
2	Washer; D5,3 X D10 X 1,0	22 01 300		
3	Hexagonal nut self securing; M5	21 05 302		
4	Dirt trap; 1,25 X 334,4 X 539,5	70004908		
5	Bracket; D8 X 869,9	70002594		Wash zone
6	Switching rod	70005398	2	incl. magnet
7	Support left; 1,5 X 70 X 82	70004889	2	
8	Fastening for switching tube; 16 X 16 X 40	70200413		
9	Hexagon screw; M6 X 10; A70	30002732	4	
10	Set collar; D20 X 12	70000595	4	
11	Support right; 1,5 X 70 X 82	70004888	2	
12	Bracket; D8 X 665,9	70002593		
13	Rack guide	70005336		
14	U-profile; 1,25 X 91,25 X 623	70002555	2	
15	Washer; D6,4 X D12,5 X 1,6	22 01 302	6	
16	Hexagon screw; M6 X 16; A70	20 01 306	6	
17	Pump sieve	70002415		
18	Guide rail; 1,5 X 28,6 X 150	70003048	2	
19	Cup screw; M5 X 10	75100426		
20	Bracket; 1,25 X 48,8 X 60	70002409		
21	Hexagonal nut; M6	21 01 304		
22	Baffle plate; 1,25 X 239,4 X 563,5	70002483		
23	Elbow; 1,25 X 87,6 X 930	70003217		
23	Elbow; 1,25 X 87,6 X 930	70003216		
24	Strainer; 1,25 X 324,5 X 348,25	70002414		
25	Supporting bow; 1236 LG	70002559	2	up to machine no.: 408 489
25	Supporting bow	70004910	2	from machine no.: 408 490

WKT 1200

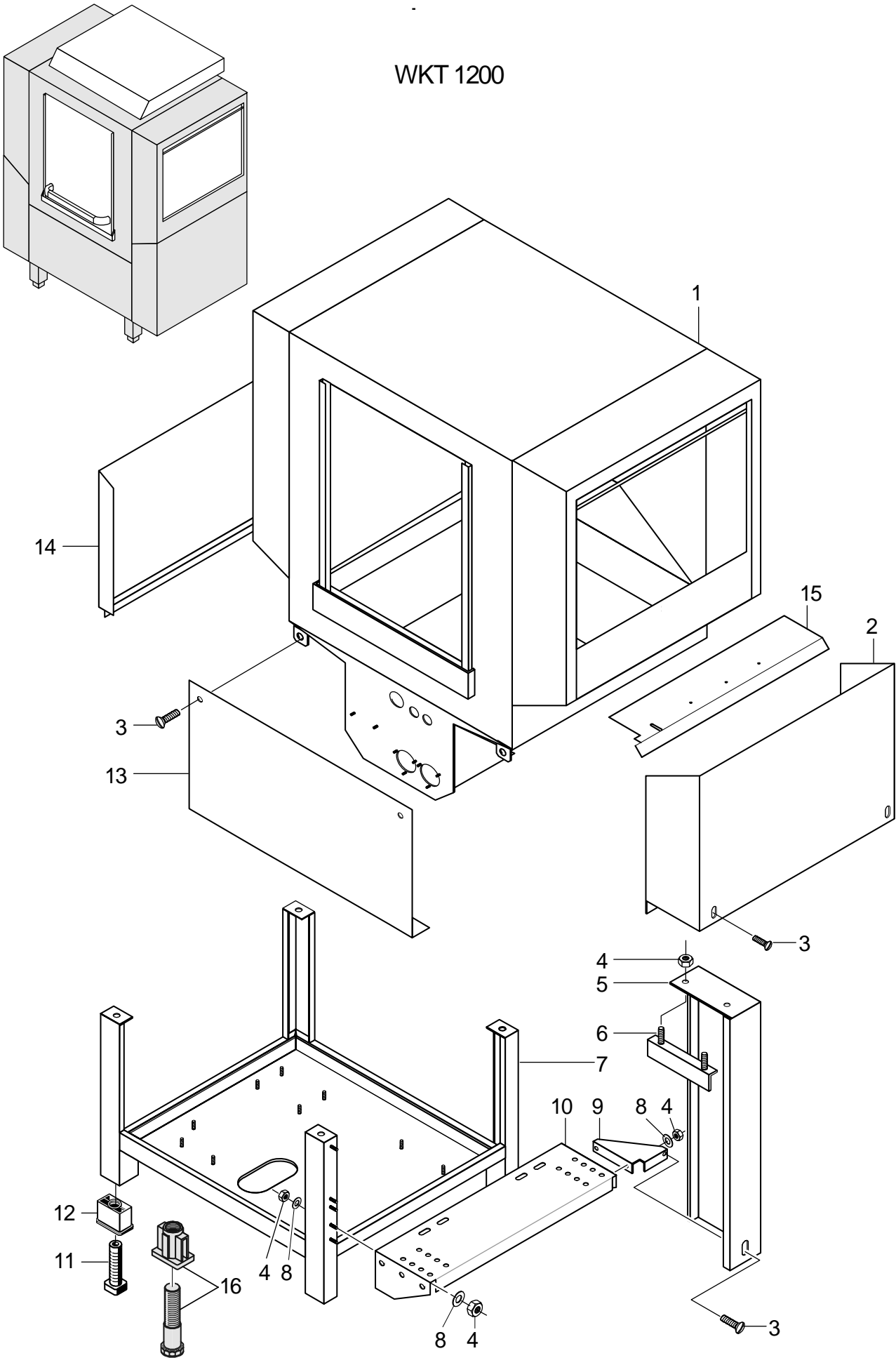

70004953-00

WKT 1200

Chassis, container and panelling

Item.	Designation	Parts no.	Pc.	Notes
1	Housing cpl. L-R; 1300 LG	70002473		
1	Housing cpl. R-L; 1300 LG	70002479		
2	Housing	70002489		
3	Cup screw; M5 X 10	75100426		
4	Hexagonal nut; M6	21 05 304		
5	Panelling; 1,25 X 269,5 X 807,5	70002430		
6	Elbow	65003534		
7	Base frame; 950 LG	70002362		
8	Washer; D6,4 X D12,5 X 1,6	22 01 302		
9	Bracket cpl.	70004972		
10	Support; 2,0 X 305 X 763,5	70002066		up to machine no.: 401 951
10	Support	70004971		from machine no.: 401 952
11	Adjustable foot; G 3/4"; 32 X 32 X 100	35 01 064	4	
12	Threaded insert; G 3/4"; 42 X 62 X 50	35 01 063	4	
13	Housing	70002487		
14	Housing	70002488		
15	Set splash guard	55 28 288		retrofitable
16	Adjustable foot with threaded insert	61008117		
o.P.	Back panel; 1,0 X 1142 X 1389	80002173		

WKT 1200

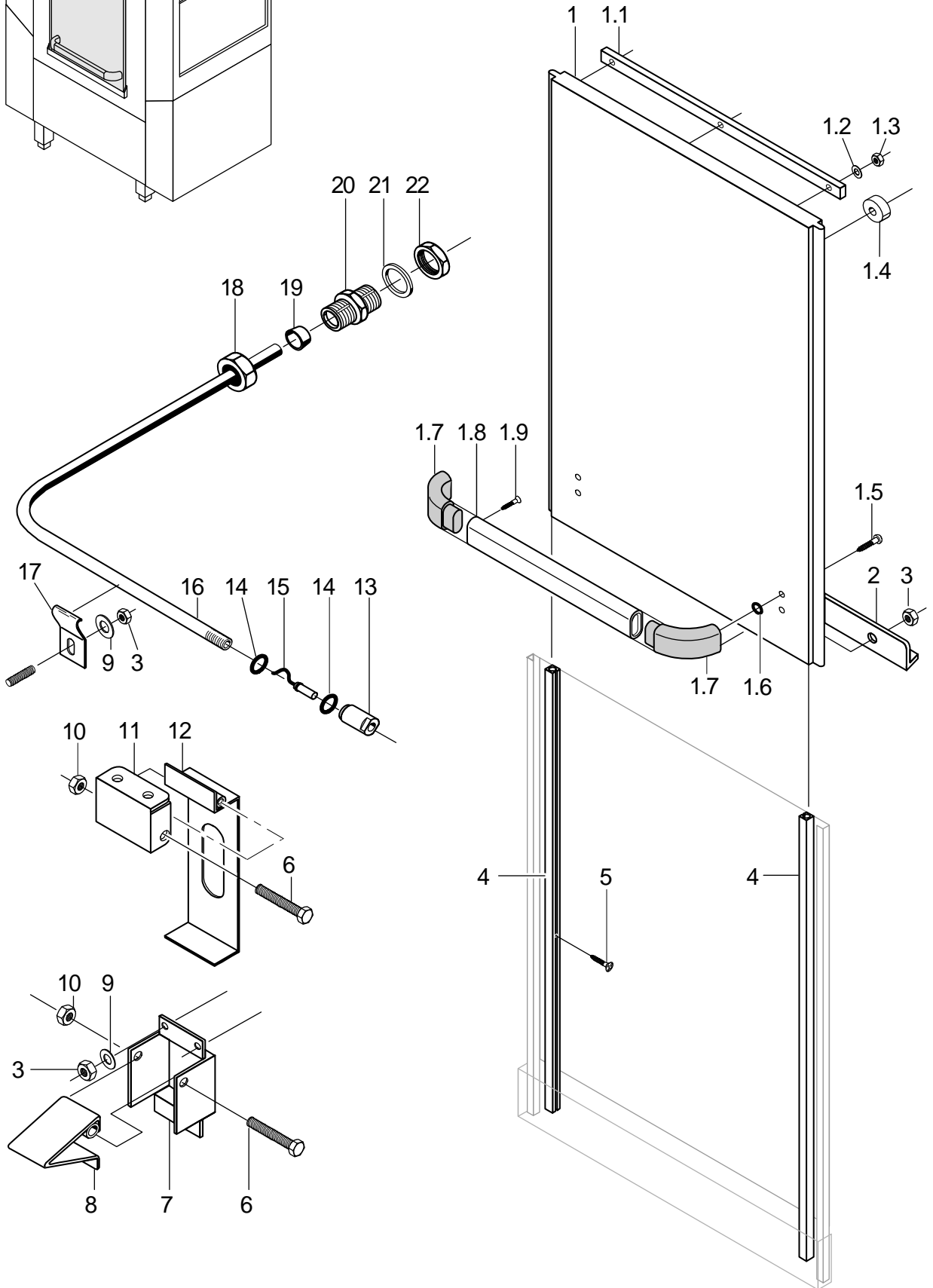
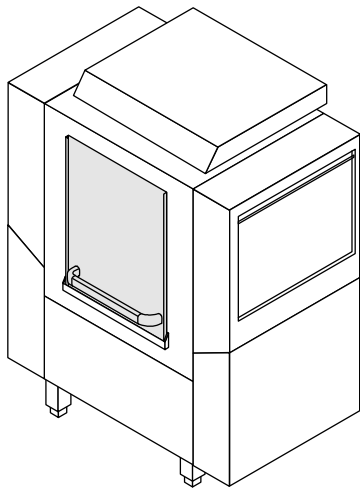

70004954-00

WKT 1200

Door

Item.	Designation	Parts no.	Pc.	Notes
1	Sliding door	70200065		incl. item 1.1 - 1.9
1.1	Cover; 10,5 X 25 X 548	70200530		
1.2	Washer; D5,3 X D10 X 1,0	22 01 300		
1.3	Hexagonal nut self securing; M5	21 05 302		
1.4	Magnet support	70200366		incl. magnet
1.5	PT screw; KB 50 X 16	20 17 301	4	
1.6	O-ring; 7 X 2,5	27 07 013	4	
1.7	Connection corner; 45 X 55 X 103,5	70200109	2	
1.8	Oval-profile; 17 X 45 X 1,2 X 403	70200302		
1.9	PT screw; KB 40 X 12	20 17 302	2	
2	Elbow; 1,25 X 37,5 X 545	70200208		
3	Hexagonal nut self securing; M5	21 05 302		
4	Sliding rail; 18,3 X 19,7 X 715 LG	70200250	2	
5	Sheet metal screw; ST 2,9 X 6,5	20 20 308	3	
6	Hexagon screw; M8 X 80; A70	20 01 364	2	
7	Bracket; 1,5 X 120 X 169	70002439		
8	Stop	70002437		
9	Washer; D5,3 X D10 X 1,0	22 01 300		
10	Hexagonal nut; M8	21 05 306		
11	Bracket; 2,0 X 114 X 140	70002535		
12	Stop	70002437		
12	Notch lever	70200077		
13	Coupling nut; M12 X 1,0 X D8,2; SW13	55 18 032		
14	O-ring; 7 X 1,5	27 07 014		
15	Magnetic switch; KABELLÄNGE 2500	31 24 134		
16	Cable pipe; D12 X 1,5 X 1023	70002441		
17	Pipe clamp; 1,25 X 20 X 49	55 04 057	2	
18	Coupling nut; G 1/2" X D12,2; SW24	29 07 301		
19	Cutting ring; D12 X 10	29 07 300		
20	Double nipple; G 1/2" X 38; SW27	30 11 301		
21	Gasket; D21 X D28 X 2,0	27 09 011		
22	Hexagonal nut; G 1/2" X 8,0; SW27	30 09 201		

WKT 1200

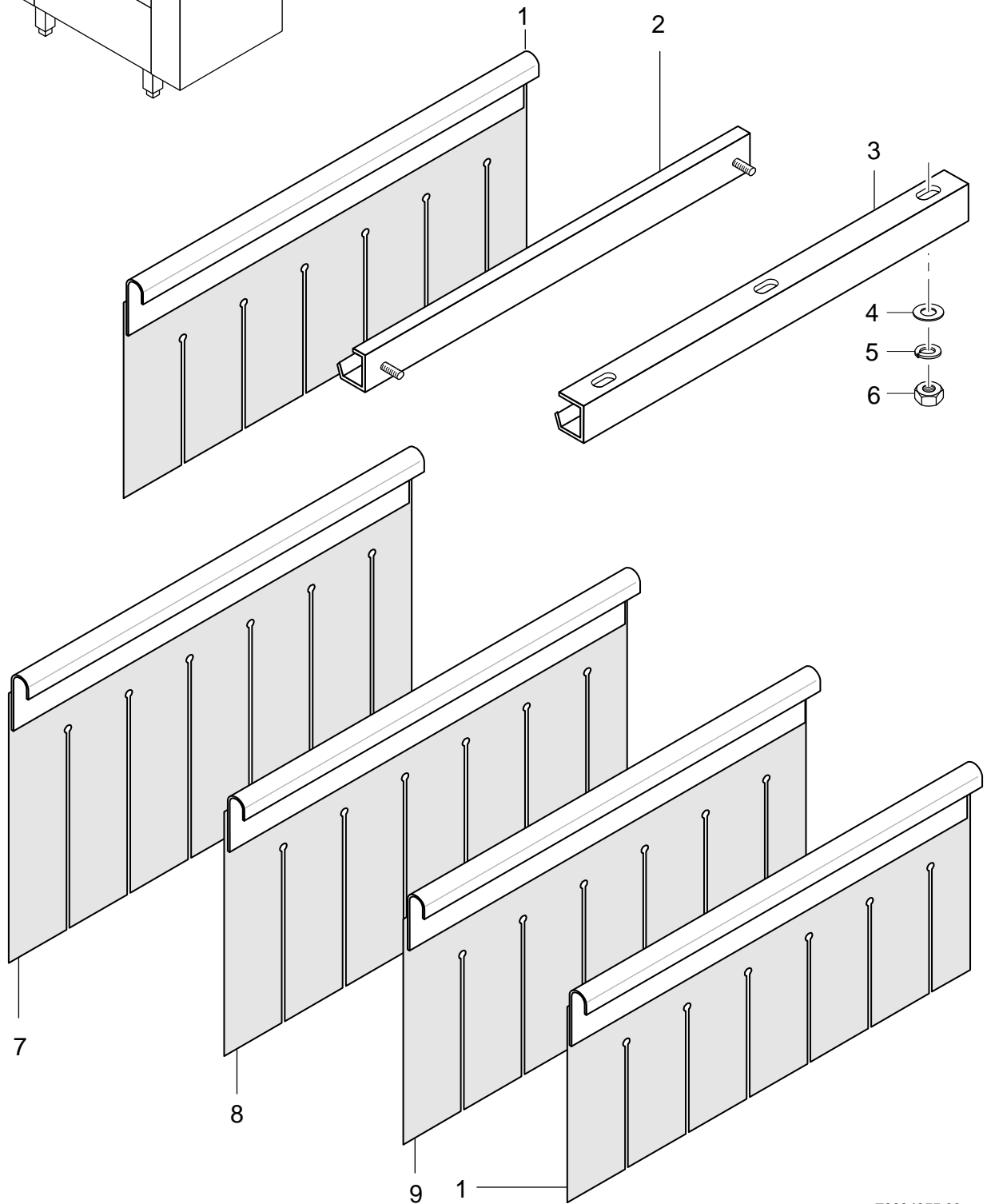
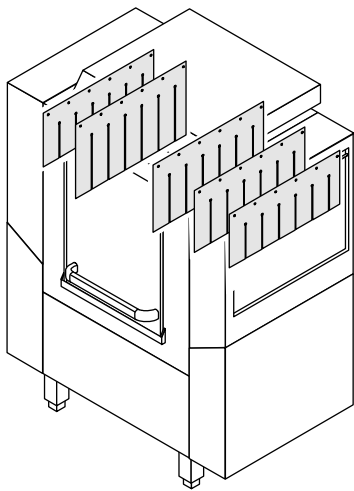

70004955-00

WKT 1200

Curtains

Item.	Designation	Parts no.	Pc.	Notes
1	Curtain cpl.; 500 LG	70002255	2	Nr. 1 + 5
2	U-profile	70002329	2	
3	Rail; 1,5 X 90 X 658	70002328		
4	Spring washer; B6	23 03 300		
5	Washer; D6,4 X D12,5 X 1,6	22 01 302		
6	Hexagonal nut; M6	21 05 304		
7	Curtain cpl.; 250 LG	70002270		Nr. 2
8	Curtain cpl.; 420 LG	70002271		Nr. 3
9	Curtain cpl.; 335 LG	70002272		Nr. 4

WKT 1200

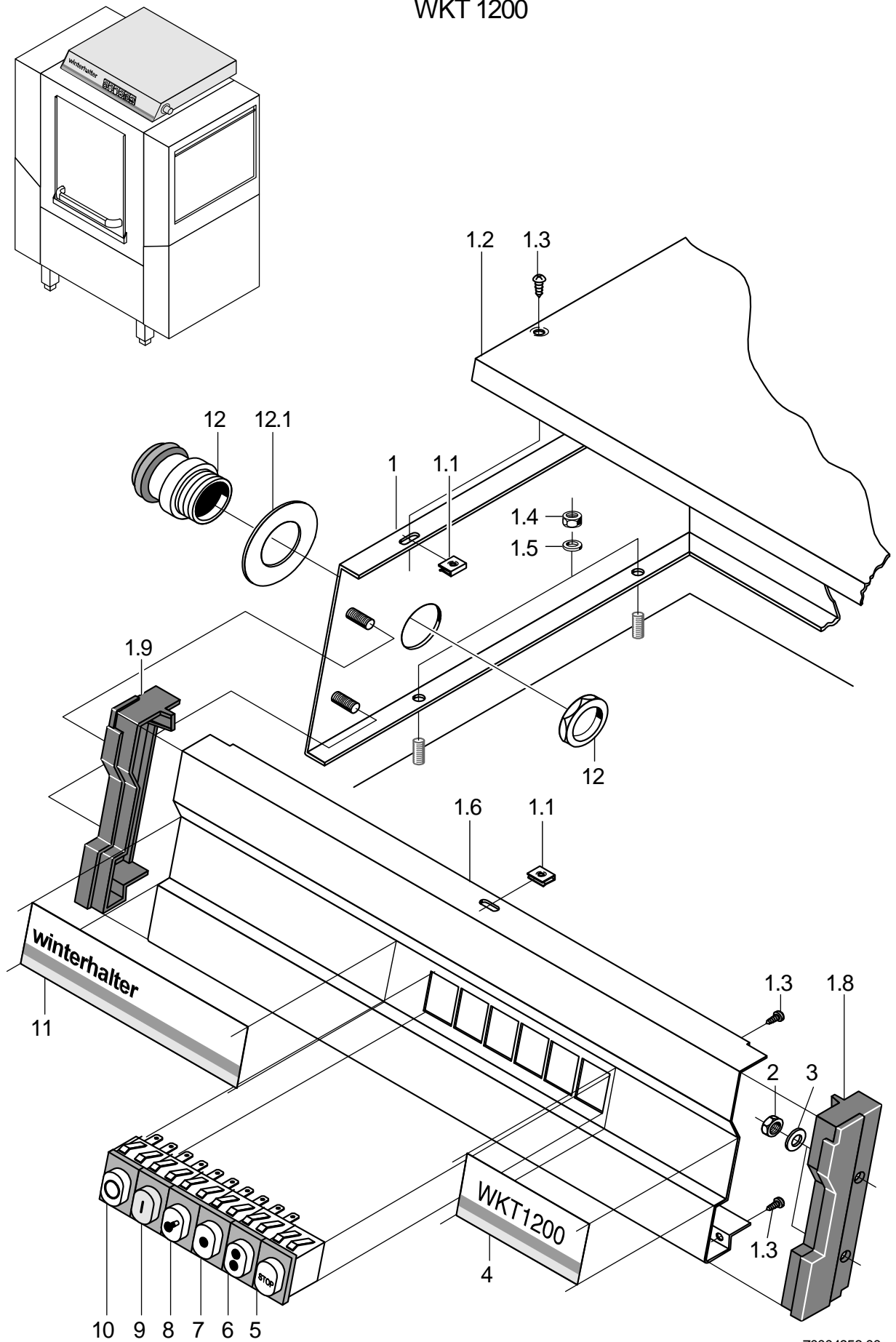

70004956-00

WKT 1200

Electrical parts I

Item.	Designation	Parts no.	Pc.	Notes
1	Switch box housing; 131 X 700 X 710	70002368		incl. item 1.1 - 1.9
1.1	Sheet metal nut; B 3,9	21 17 002		
1.2	Switch box cover; 0,8 X 686 X 730,8	70002377		
1.3	Sheet metal screw; ST 3,9 X 16	20 20 300	6	
1.4	Hexagonal nut self securing; M4	21 05 300		
1.5	Washer; D4,3 X D12 X 1,0	22 05 300		
1.6	Switch box screen; 0,8 X 236,6 X 701,6	70002374		
1.8	Switch box corner right	65002642		
1.9	Switch box corner left	65002641		
2	Hexagonal nut self securing; M4	21 05 300		
3	Washer; D4,3 X D12 X 1,0	22 05 300		
4	Strip label WKT 1200; 0,4 X 38 X 203,8	70002493		
5	Pressure key "stop"; 250V; AC; 1-POL; IP54	31 24 164		
6	Pressure key "Programme II"; 250V; AC; 1-POL/W;IP54	31 24 163		
7	Pressure key "Programme I"; 230V; AC; 1-POL/W;IP54	31 24 162		
8	Lamp with extinction resistor; 230V; IP54	31 08 116		
9	Pressure key -ON-; 250V; AC; 1-POL; IP54	31 24 160		
10	Pressure key -OFF-; 250V; AC; 1-POL; IP54	31 24 161		
11	Plate Winterhalter; 0,4 X 38 X 331,8	65002959		
12	Emergency off key; 30MM; ROT	31 24 193		
12.1	Emergency off plate; 60 X 1,0MM; ENGL./FRZ.	31 24 195		

WKT 1200

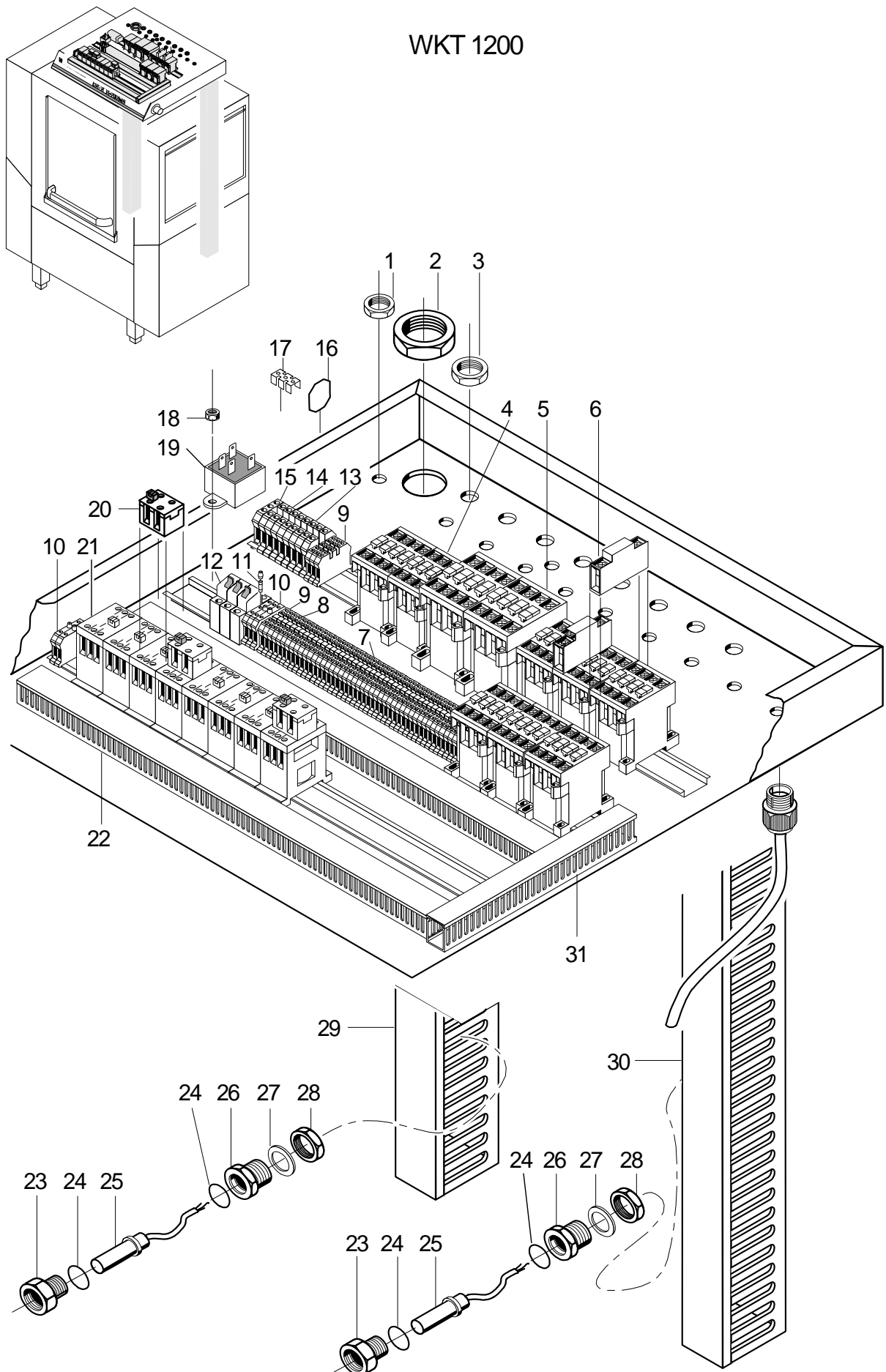

70004957-00

WKT 1200

Electrical parts II up to machine no.: 430 048

Item.	Designation	Parts no.	Pc.	Notes
1	Hexagonal nut; PG9	31 10 043	7	
1	Hexagon bolt; PG9	31 10 021		
1	PG9 cable gland; PG9; 4-8 MM; IP68	31 10 042	6	
2	Hexagonal nut; PG48 X 8; SW70	31 10 138		
2	Cable gland; PG48; 34 - 44 MM	31 10 137		
2	Cable gland; PG36; 22 - 32 MM	31 10 136		
2	Reducing ring; PG48/PG36	31 10 140		
3	Hexagonal nut; PG16; SW30;	31 10 110	11	
3	Cable gland PG16; PG16; 10-14 MM; IP68	31 10 049		
3	Locking screw; PG16	31 10 025		
4	Contacteur AF16; 100-250V/50-60HZ AC/DC; 7,5KW	30000861		
5	Kit Contacteur AF30; 100-250V/50-60HZ AC/DC; 15KW	30008327		
6	Auxiliary switch, 1 N/O contact	31 04 166	2	
7	UDK 4 double terminal	31 09 151	35	
8	UDK 4 BU double terminal	31 09 152	4	
9	UDK 4-PE double terminal	31 09 153	5	
10	Fuse terminal; 10 A	31 09 149	5	
11	Fine fuse, medium time lag; 250V; 6,3A; 5 X 20	31 11 043	10	
12	Circuit breaker; 1-POLIG; 16A-B	31 11 100	3	
13	Universal terminal block, grey; UK 35	31 09 172		
14	Universal terminal block, UK 35, blue	31 09 173		
15	Protective conductor terminal USKLG 5	31 09 064	2	
16	Isolating disc; 14 X 16	31 09 169	2	
17	Fixed bridge; 3-POLIG; FB 3-6	31 09 136	2	
18	Hexagonal nut self securing; M4	21 05 300	2	
19	Radio interference suppression capacitor; AC 250/440 VOLT	31 13 072		
19	Radio interference suppression capacitor; 33000 PF Y; 250 VOLT A	31 13 073		
20	Contact modul; PV 11	31 04 130	3	
21	Mini contacteur; 220V/50-60HZ; 240V/60H	31 04 114		
21	Mini contacteur; 220V/50-60HZ; 240V/60H	31 04 115	7	
22	Cable channel; 65 HOCH X 46 BREIT	31 20 104		600 mm; "By-the-metre" goods
23	Threaded nipple; M12 X 1,0 X 24; SW19	70002490	2	
24	O-ring; 7 X 1,5	27 07 014	2	
25	Magnetic switch; KABELLÄNGE 2500	31 24 134	2	
26	Reducing piece; M12 X 1,0 X G3/8";SW24	70002428	2	
27	Gasket; D17 X D24 X 2,0	27 09 009		
28	Hexagonal nut; G 3/8" X 5,5; SW22	30 09 200	2	
29	Cable channel; 23 HOCH X 31 BREIT	31 20 118		800 mm; "By-the-metre" goods
30	Cable channel; 65 HOCH X 46 BREIT	31 20 104		750 mm; "By-the-metre" goods
31	Cable channel; 65 HOCH X 46 BREIT	31 20 104		300 mm; "By-the-metre" goods
o.P.	Fixed bridge; 2-POLIG; FB 2-15	31 09 175		
o.P.	Wire assortment control; 0,75QMM	70002445		
o.P.	Wire assortment; three-phase STAR	70002444		
o.P.	Wire assortment control panel	70002443		
o.P.	Clamp strap; 3,2 X 14 X 19,8	31 09 095		
o.P.	Hexagonal nut; M6	21 01 304		
o.P.	Washer; D6,4 X D12,5 X 1,6	22 01 302		
o.P.	Protection symbol green/yellow; D16	31 09 096		
o.P.	Fixed bridge; 2-POLIG;	31 09 126		
o.P.	Fixed bridge; 4-POLIG; FB 4-6	31 09 146		
o.P.	Fixed bridge; 3-POLIG;	31 09 176		
o.P.	Isolating disk	31 09 066		

430049 ...

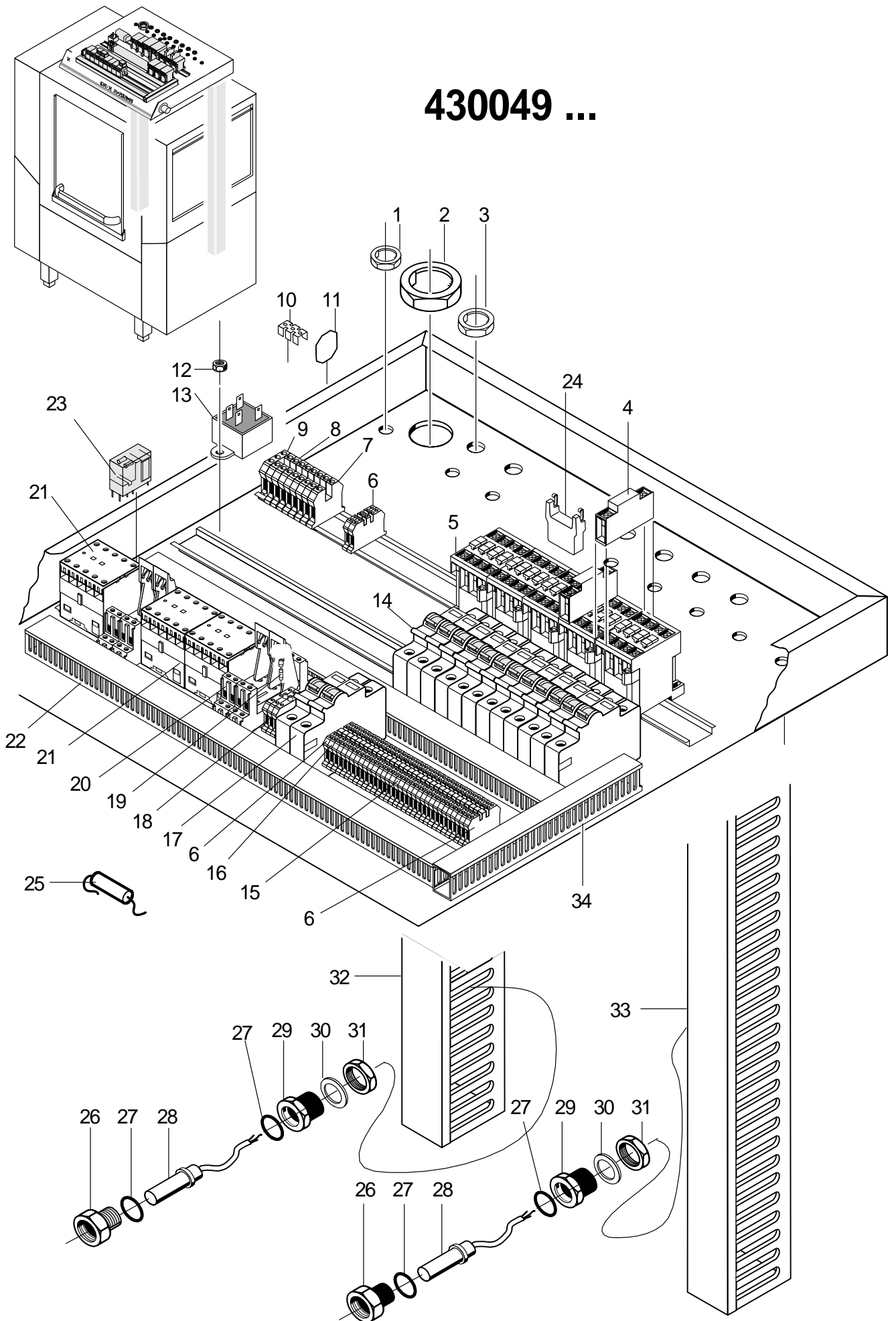

WKT 1200

Electrical parts II from machine no.: 430 049

Item.	Designation	Parts no.	Pc.	Notes
1	Hexagonal nut; PG9	31 10 043	7	
1	Hexagon bolt; PG9	31 10 021		
1	PG9 cable gland; PG9; 4-8 MM; IP68	31 10 042	6	
2	Hexagonal nut; PG48 X 8; SW70	31 10 138		
2	Cable gland; PG48; 34 - 44 MM	31 10 137		
2	Cable gland; PG36; 22 - 32 MM	31 10 136		
2	Reducing ring; PG48/PG36	31 10 140		
3	Hexagonal nut; PG16; SW30;	31 10 110	11	
3	Cable gland PG16; PG16; 10-14 MM; IP68	31 10 049	8	
3	Locking screw; PG16	31 10 025	3	
4	Auxiliary switch, 1 N/O contact	31 04 166	2	
5	Contactor AF16; 100-250V/50-60HZ AC/DC; 7,5KW	30000861		
6	UDK 4-PE double terminal	31 09 153	5	
7	Universal terminal block, UK 35, blue	31 09 173		
8	Universal terminal block, grey; UK 35	31 09 172		
9	Protective conductor terminal USLKG 35	31 09 174		
10	Fixed bridge; 3-POLIG;	31 09 176	2	
10	Fixed bridge; 2-POLIG; FB 2-15	31 09 175	2	
11	Isolating disc; 14 X 16	31 09 169	2	
12	Hexagonal nut self securing; M4	21 05 300	2	
13	Radio interference suppression capacitor; AC 250/440 VOLT	31 13 072	2	
14	Circuit breaker; 1-POLIG; 10A-B	31 11 110		
14	Circuit breaker; 1-POLIG; 20A-B	31 11 111		
15	UDK 4 double terminal	31 09 151	35	
16	UDK 4 BU double terminal	31 09 152	4	
17	Circuit breaker; 1-POLIG; 6A-B	31 11 101	3	
18	Fuse terminal; 10 A	31 09 149	5	
19	Fine fuse, medium time lag; 250V; 6,3A; 5 X 20	31 11 043	10	
20	Socket, snap fixture; RASTER 5,0	31 04 157		
21	Contactor B7:3H 1 N/C contact; 220-255V/50-60HZ	31 04 154		
21	Contactor B7:3H 1 N/C contact; 200V/50-60HZ	31 04 171		Japan
22	Cable channel; 65 HOCH X 46 BREIT	31 20 104		600 mm; "By-the-metre" goods
23	Print relay 1 changer; 230V AC;16A;RASTER 5,0	31 04 158		
24	Varistor; 110-250V AC	31 04 168		
25	Radio interference suppression capacitor; 33000 PF Y; 250 VOLT A	31 13 073		
26	Threaded nipple; M12 X 1,0 X 24; SW19	70002490	2	
27	O-ring; 7 X 1,5	27 07 014	2	
28	Magnetic switch; KABELLÄNGE 2500	31 24 134	2	
29	Reducing piece; M12 X 1,0 X G3/8";SW24	70002428	2	
30	Gasket; D17 X D24 X 2,0	27 09 009		
31	Hexagonal nut; G 3/8" X 5,5; SW22	30 09 200	2	
32	Cable channel; 23 HOCH X 31 BREIT	31 20 118		800 mm; "By-the-metre" goods
33	Cable channel; 65 HOCH X 46 BREIT	31 20 104		750 mm; "By-the-metre" goods
34	Cable channel; 65 HOCH X 46 BREIT	31 20 104		300 mm; "By-the-metre" goods
o.P.	Wire set Control; 0,75QMM	70004974		
o.P.	Wiring loom (base frame)	70004976		

WKT 1200

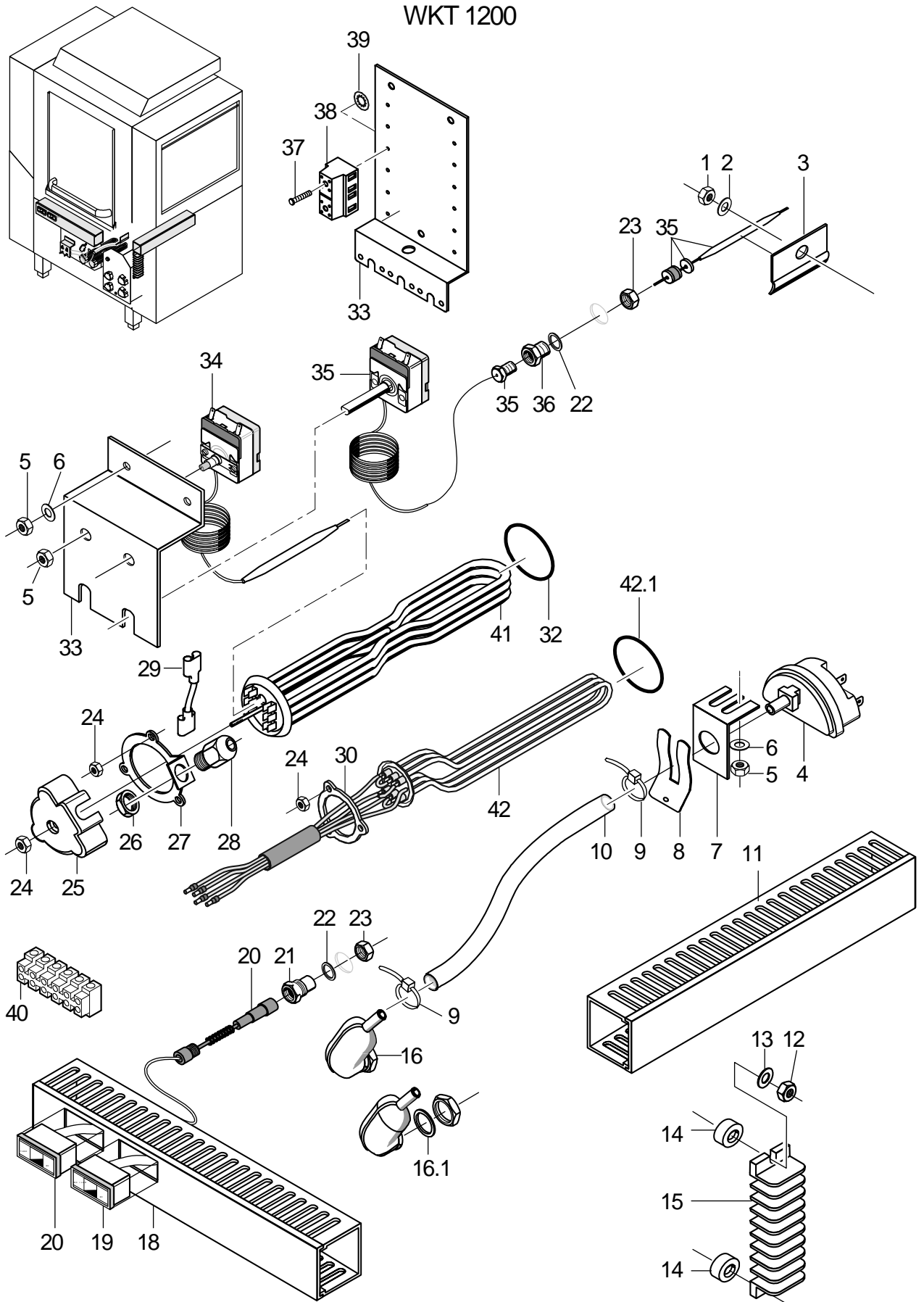

70004958-00

WKT 1200

Electrical parts III

Item.	Designation	Parts no.	Pc.	Notes
1	Hexagonal nut self securing; M5	21 05 302		
2	Washer; D5,3 X D10 X 1,0	22 01 300		
3	Thermostat clamp; 0,8 X 28 X 50	55 19 011		
4	Level control; 250V/50-60HZ	31 26 003		
5	Hexagonal nut; M6	21 05 304		
6	Washer; D6,4 X D12,5 X 1,6	22 01 302		
7	Level control bracket; 1,25 X 50 X 75	61002345		
8	Retaining spring for leveller	31 26 001		
9	Cable tie; 100 X 2,5	31 20 175		
10	Hose; DN5 X 1,5	40 01 024		600 mm; "By-the-metre" goods
11	Cable channel; 65 HOCH X 46 BREIT	31 20 104		460 mm; "By-the-metre" goods
12	Hexagonal nut self securing; M4	21 05 300		
13	Washer; D4,3 X D8 X 0,5	22 02 202		
14	Spacer; D5,3 X D12 X 7	22 08 513	2	
15	Terminal strip; 16-POLIG	31 09 154		
16	Air chamber	55 04 030		incl. item 16.1
16.1	O-ring; 24 X 3,0	27 07 087		
18	Cable channel; 65 HOCH X 46 BREIT	31 20 104		600 mm; "By-the-metre" goods
19	Thermometer 85 degrees; MESSLEITUNG 2500 LG	32 01 036		
20	Thermometer 58 degrees; MESSLEITUNG 2500 LG	32 01 035		
21	Gland for thermometer; M14 X 1,0 X 35,5; SW19	32 01 030		
22	Gasket; D14,2 X D20 X 2,0	27 09 036		
23	Hexagonal nut; M14 X 1,0 X 5,0	31 25 002		
24	Hexagonal nut; M5	21 01 203		
25	Element cover; 50 X D67 X 89,5	31 03 014		up to machine no.: 430 048
26	Hexagonal nut; PG13,5	31 10 041		up to machine no.: 430 048
27	Clamping plate; D43 X D80 X 4,0	55 19 018		up to machine no.: 430 048
28	Cable gland PG13.5; PG13,5; 6-12 MM; IP68	31 10 040		up to machine no.: 430 048
29	Star bridge; 2,5QMM; 90 LG	70004616		up to machine no.: 430 048
30	Locking washer; D43 X D80 X 4,0	01 17 003		from machine no.: 430 049
32	O-ring; 43 X 7,0	27 07 088		
33	Bracket; 1,5 X 97,5 X 138	70001224		up to machine no.: 430 048
33	Bracket; 1,25 X 120 X 282,6	70004970		from machine no.: 430 049
34	Safety thermostat; 160 GRAD C -12K "AUS"	31 25 030	2	up to machine no.: 430 048
35	Thermostat; 1750 LG; 220V	31 25 013	2	
36	Gland for thermostat; M14 X 1,0 X 15; SW19	31 25 001		
37	Lens head screw with hexagon socket; M4 X 20	20 10 003		
38	Appliance terminal G10/4; 4-POLIG; 10QMM	31 09 227		
39	Sleeve nut; M4	21 13 000		
40	Binding post; 6-POLIG; 6QMM; 62LG	31 09 236		from machine no.: 485 745
41	Heating element cranked 5,0kW; 230V/400V/3	31 03 030	2	up to machine no.: 430 048
41	Heating element cranked 5,0kW; 240V/420V/3	31 03 032	2	up to machine no.: 430 048
41	Heating element cranked 5,0kW; 200V/346V/3	31 03 098	2	up to machine no.: 430 048
41	Heating element cranked 5,0kW; 254V/440V/3	31 03 031	2	up to machine no.: 430 048
42	Heating element, wash tank 5.0 kW with fuse; 400-440V, 3~, 5KW	30008058	2	from machine no.: 430 049
42	Heating element, wash tank 5,0 kW with fuse; 230V, 3~, 5KW	30008057	2	from machine no.: 430 049
42	Heating element, wash tank 4,7/6,2 kW with fuse; 200V, 3~, 4,7KW/230V, 3~, 6,2KW	30008049	2	from machine no.: 430 049
42.1	O-ring; 43 X 7,0	27 07 088		

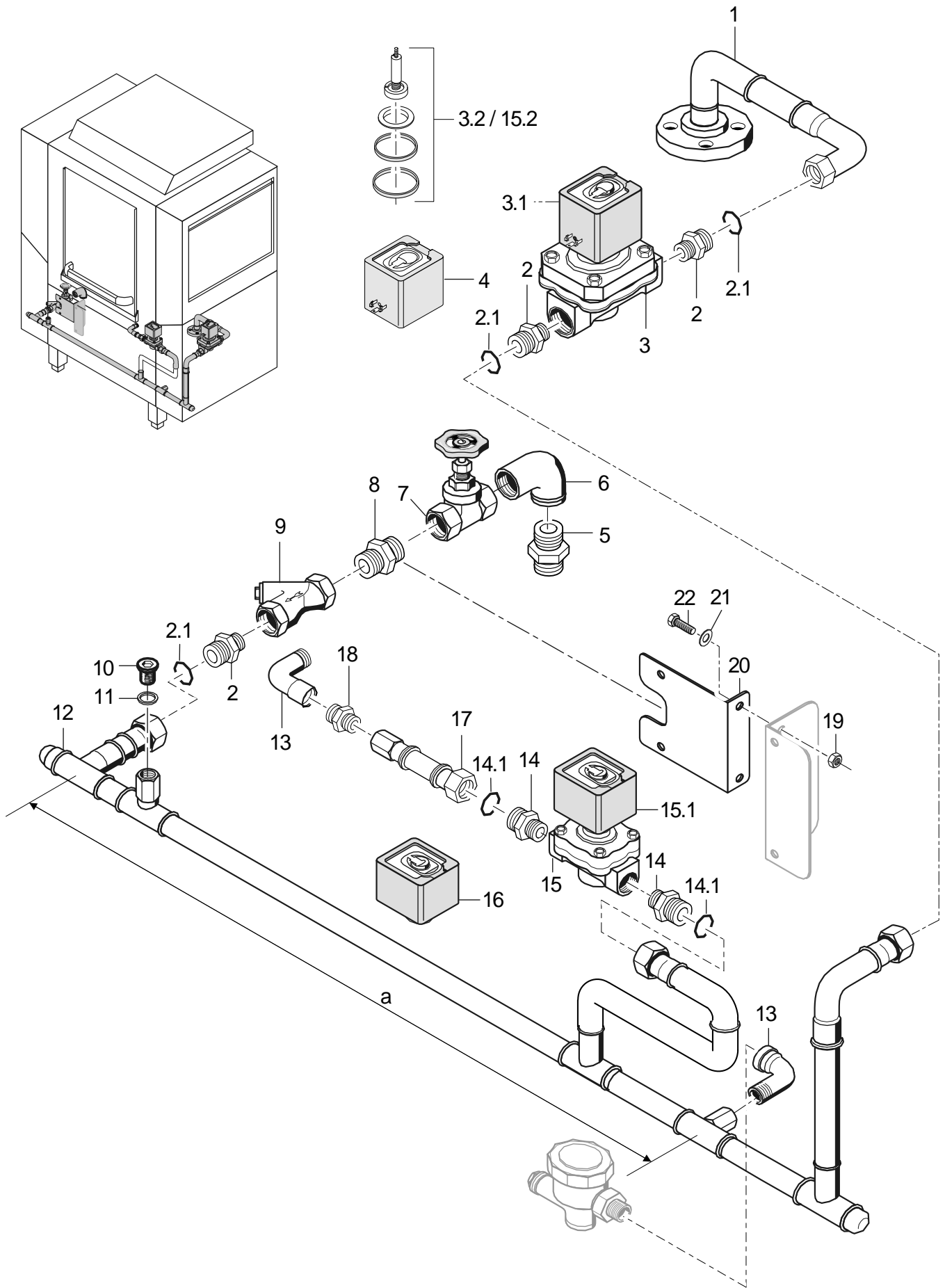

WKT 1200 70005363-01

WKT 1200

Steam pipes and steam valves

Item.	Designation	Parts no.	Pc.	Notes
1	Boiler inlet pipe	70005524		from machine no.: 478 963 ; with older machines: contact with factory necessary
2	Reducing nipple; G 1 1/4" X R 1"; SW46	70005632		incl. item 2.1
2.1	O-ring; 28 X 3 (28,3 X 3,1)	27 07 078		
3	2/2-Way solenoid valve; R1"BSP;11,6KV;0,35-3,5	31 06 142		incl. item 3.1 - 3.2
3.1	Coil; 230V/50HZ	31 06 170		
3.2	Repair kit solenoid valve; R 1"	31 06 146		
4	Coil; 220V/60HZ	31 06 171		
4	Coil; 200V/50HZ	31 06 172		
4	Coil; 200V/60HZ	31 06 173		
5	Double nipple; G 1" X 54; SW41	30 11 011		
6	Elbow; R 1"	30 02 010		
7	Sleeve slide valve; R 1"	29 03 100		
8	Double nipple; R 1" X 40	70004142		
9	Dirt trap; G 1" X 80	28 07 200		
10	Screw plug; G 1/2"	30 08 303		
11	Gasket; D21 X D28 X 2,0	27 09 011		
12	Conversion set steam pipes	70005631		up to 12/2001
12	Distributor pipe assembly	70005515		from 01/2002 - 478962 ; a=930mm
12	Distributor pipe assembly	70005516		from machine no.: 478 963 ; a=906mm
13	Elbow; R 1/2"	30 02 111		
14	Reducing nipple; G 3/4" X R 1/2"; SW27	70005633		incl. item 14.1
14.1	O-ring; 18 X 2,5 (18,2 X 2,6)	27 07 077		
15	2/2-Way solenoid valve; R1/2";230-240V;50-60HZ	31 06 143		incl. item 15.1 - 15.2
15.1	Coil; 220V/50HZ	31 06 147		
15.2	Repair kit solenoid valve; R 1/2"	31 06 145		
16	Coil; 220V/60HZ	31 06 149		
16	Coil; 200V/50HZ	31 06 156		
16	Coil; 200V/60HZ	31 06 157		
17	Distributor pipe assembly	70005534		from machine no.: 478 963 ; with older machines: contact with factory necessary
18	Double nipple; G 1/2" X 30; SW27	70000459		
19	Hexagonal nut; M6	21 05 304		
20	Bracket; 2,0 X 80 X 136	70003948		
21	Washer; D6,4 X D12,5 X 1,6	22 01 302		
22	Hexagon screw; M6 X 10; A70	30002732		

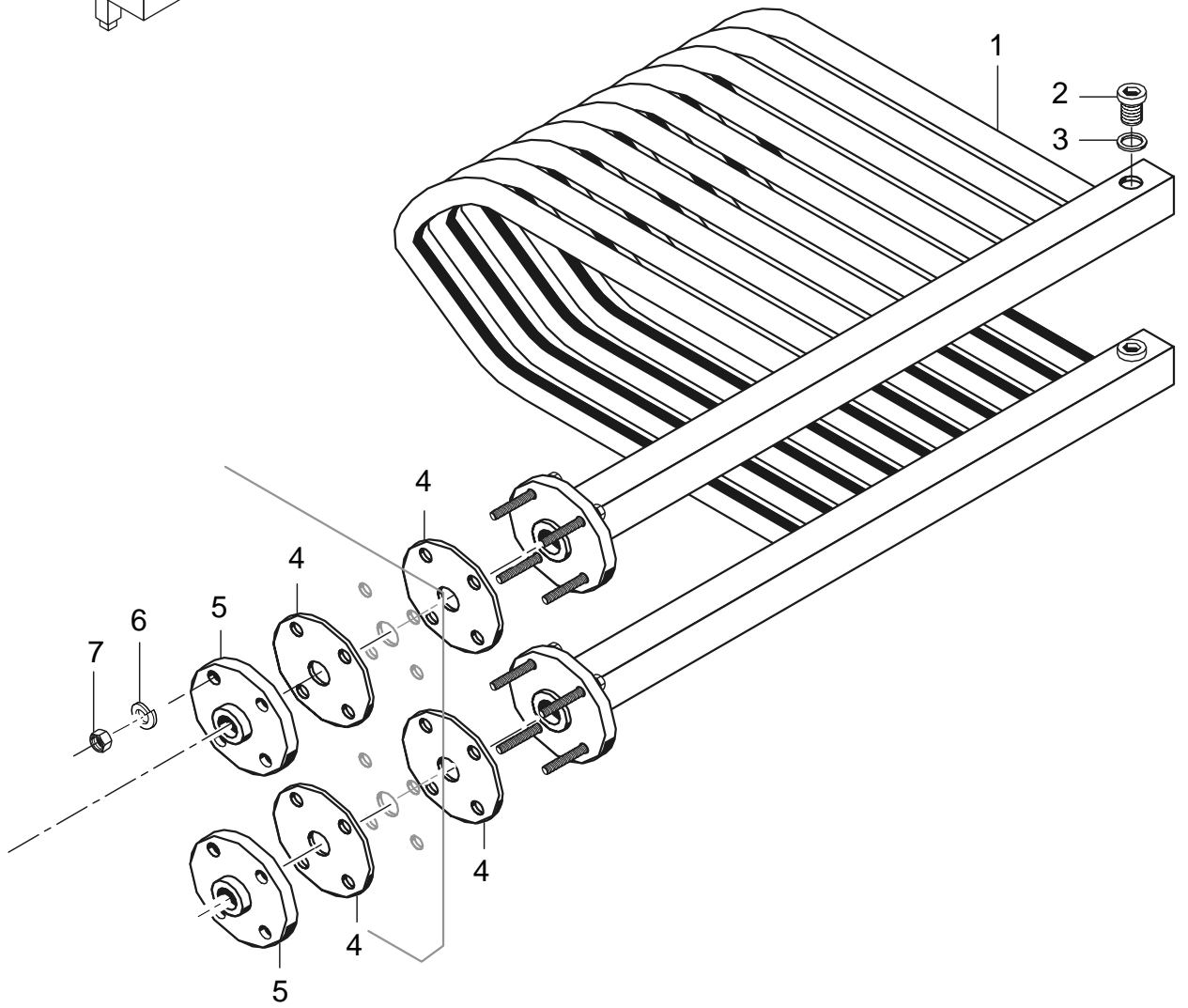
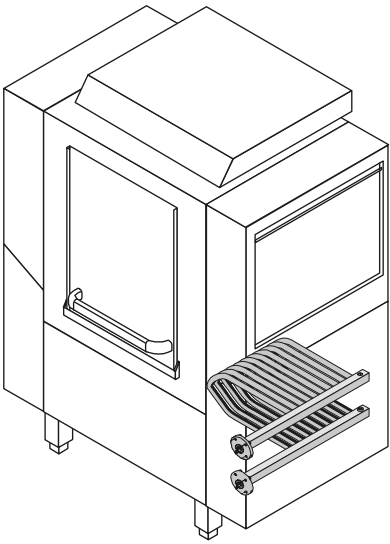

WKT 1200 70005364-01

WKT 1200

Steam tank heater

Item.	Designation	Parts no.	Pc.	Notes
1	Steam heating element	70004478		
2	Screw plug; G 1/2"	30 08 303		
3	Gasket; D21 X D30 X 2,0	27 09 017		
4	Gasket; D15 X D95 X 2,0	70004104		
5	Threaded flange; D95 X 17,5; G 1/2"	70004607		
6	Spring washer; B12	23 03 305		
7	Hexagonal nut; M12 x 6	21 02 307		

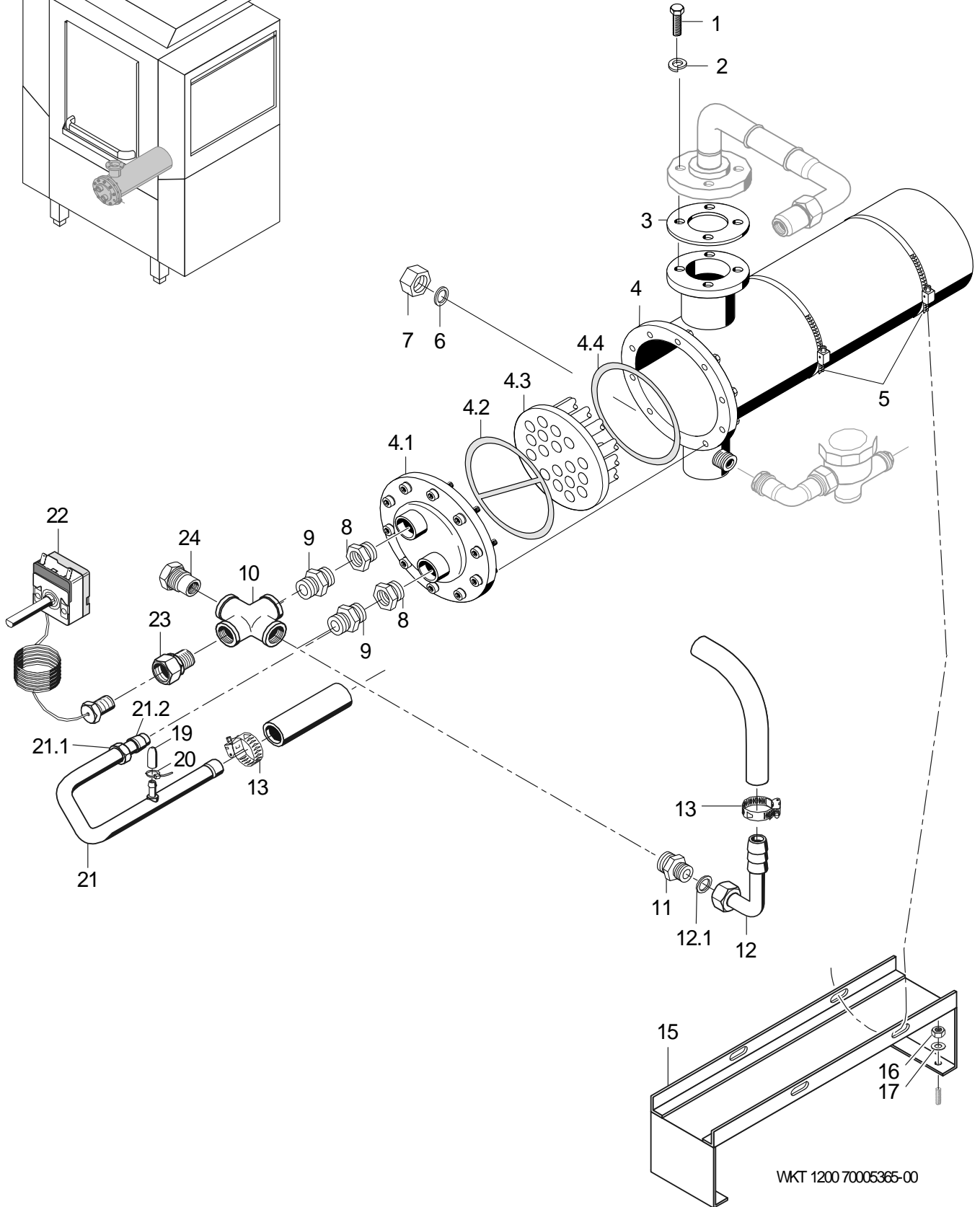
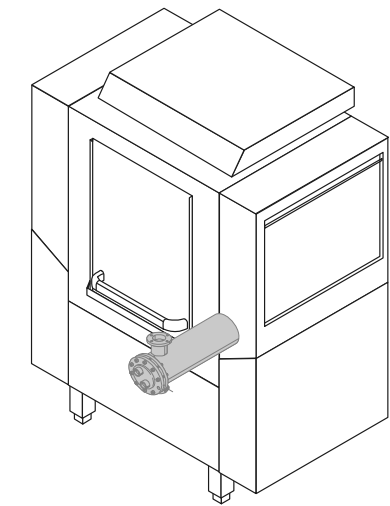

WKT 1200 70005365-00

WKT 1200

Steam boiler

Item.	Designation	Parts no.	Pc.	Notes
1	Hexagon screw; M12 X 30	20 01 370		
2	Spring washer; B12	23 03 305		
3	Gasket; D51,5 X D105 X 2,0	70004103		
4	Counterflow device cpl.	70004108		incl. item 4.1 - 4.4
4.1	Connecting flange counterflow device	28 13 035		
4.2	KIT GASKETS STEAM BOILER	30000713		
4.3	Pipes f.reverse current device	28 13 030		
4.4	KIT GASKETS STEAM BOILER	30000713		
5	Hose clamp; D50-145 X 12	28 02 008	2	
6	Gasket; D10 X D18 X 1,5	27 09 013		
7	Locking cap; R 1/2"	29 07 204		
8	Reducing piece; R 1" X R 1/2"	30 06 304		
9	Double nipple; G 1/2" X 30; SW27	70000459		
10	Cross piece; R 1/2"	30 05 105		
11	Reducing nipple; G 1/2" X G 3/4"; SW27	61003430		
12	Hose nipple, angled; D18	60002474		incl. item 12.1
12.1	Gasket; D16 X D24 X 3,0	83001022		
13	Hose clamp; D12-22 X 9	30000711		
15	Boiler support; 1,5 X 80 X 372	70004601		
16	Hexagonal nut self securing; M5	21 05 302		
17	Washer; D5,3 X D15 X 1,2	22 05 301		
19	End cap; D5,7 X 25,4	35 06 180		
20	Cable tie; 100 X 2,5	31 20 175		
21	Boiler inlet elbow, cpl.	55 09 054		incl. item 21.1 - 21.2
21.1	Coupling nut; G 1/2" X D12,2; SW24	29 07 201		
21.2	Cutting ring; D12 X 10	29 07 300		
22	Thermostat; 1750 LG; 220V	31 25 013		
23	Bush for thermostat; G1/2" X 29; SW27	70004709		
24	Bush for thermostat; G1/2" X 35,5; SW27	70004708		

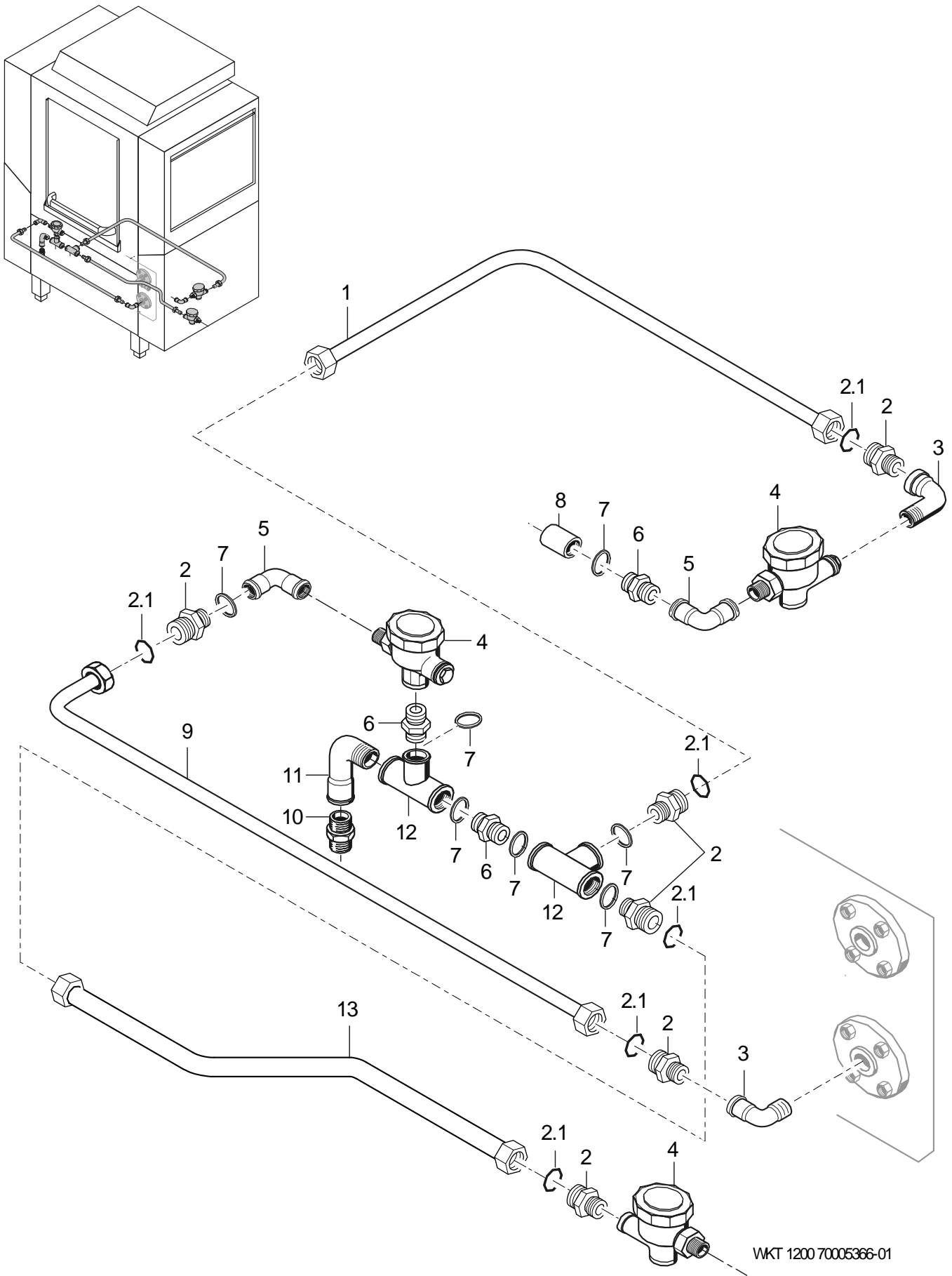

WKT 1200 70005366-01

WKT 1200

Condensate conductors

Item.	Designation	Parts no.	Pc.	Notes
1	Condensate pipe cpl.; D12X1	70005368		up to machine no.: 478 962
1	Suction elbow	70005528		from machine no.: 478 963
2	Reducing nipple; G 3/4" X R 1/2"; SW27	70005633		incl. item 2.1
2.1	O-ring; 18 X 2,5 (18,2 X 2,6)	27 07 077		
3	Elbow; R 1/2"	30 02 111		
4	Rapid condensate drain; R 1/2"	29 03 002		
5	Elbow; R 1/2"	30 02 110		
6	Double nipple; G 1/2" X 30; SW27	70000459		
7	Gasket; D20,9 X D27 X 2,0	27 04 006		
8	Sleeve; R 1/2" X D25	30 07 302		
9	Condensate pipe cpl.; D12X1	70005369		up to machine no.: 478 962
9	Suction elbow	70005532		from machine no.: 478 963
10	Reducing nipple; G 1/2" X G 3/4"; SW27	61003430		
11	Elbow; G 1/2"	30 02 301		
12	T-piece; R 1/2"	30 04 101		
13	Condensate pipe cpl.; D12X1	70005370		up to machine no.: 478 962
13	Suction elbow	70005530		from machine no.: 478 963