

Spare parts list

GS 640 / GS 650

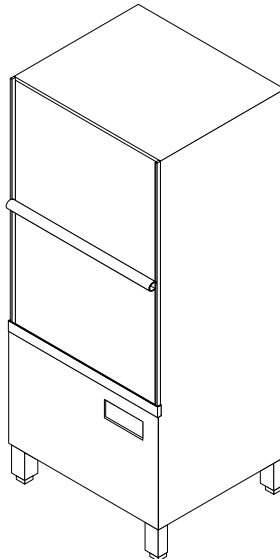

Contents

Water inlet	GS 640: ...814 318; GS 650: ...813 826	Page 1 - 2
Water inlet	GS 640: 814 319...; GS 650: 813 827...	Page 3 - 4
Tank and tank heating		Page 5 - 6
Water drain, Mediamat Cyclo		Page 7 - 8
Wash pump		Page 9 - 10
Wash system		Page 11 - 12
Reversing	GS 640: ...814 318; GS 650: ...813 826	Page 13 - 14
Reversing	GS 640: 814 319...; GS 650: 813 827...	Page 15 - 16
Pressure boiler	GS 640: ...814 318; GS 650: ...813 826	Page 17 - 18
Pressure-independent boiler	GS 640: ...814 318; GS 650: ...813 826	Page 19 - 20
Pressure-independent boiler	GS 640: 814 319...; GS 650: 813 827...	Page 21 - 22
Rinse pump		Page 23 - 24
Rinse system	GS 640: ...814 318; GS 650: ...813 826	Page 25 - 26
Rinse system	GS 640: 814 319...; GS 650: 813 827...	Page 27 - 28
Dosage		Page 29 - 30
Chassis, container and panelling	GS 640: ...814 318; GS 650: ...813 826	Page 31 - 32
Chassis, container and panelling	GS 640: 814 319...; GS 650: 813 827...	Page 33 - 34
Door		Page 35 - 36
Electric parts		Page 37 - 40
Vapour extraction	GS 640 + GS 650 Energy	Page 41 - 42
Cold water pre-rinse (optional)	GS 640: ...814 318; GS 650: ...813 826	Page 43 - 44
Cold water pre-rinse (optional)	GS 640: 814 319...; GS 650: 813 827...	Page 45 - 46

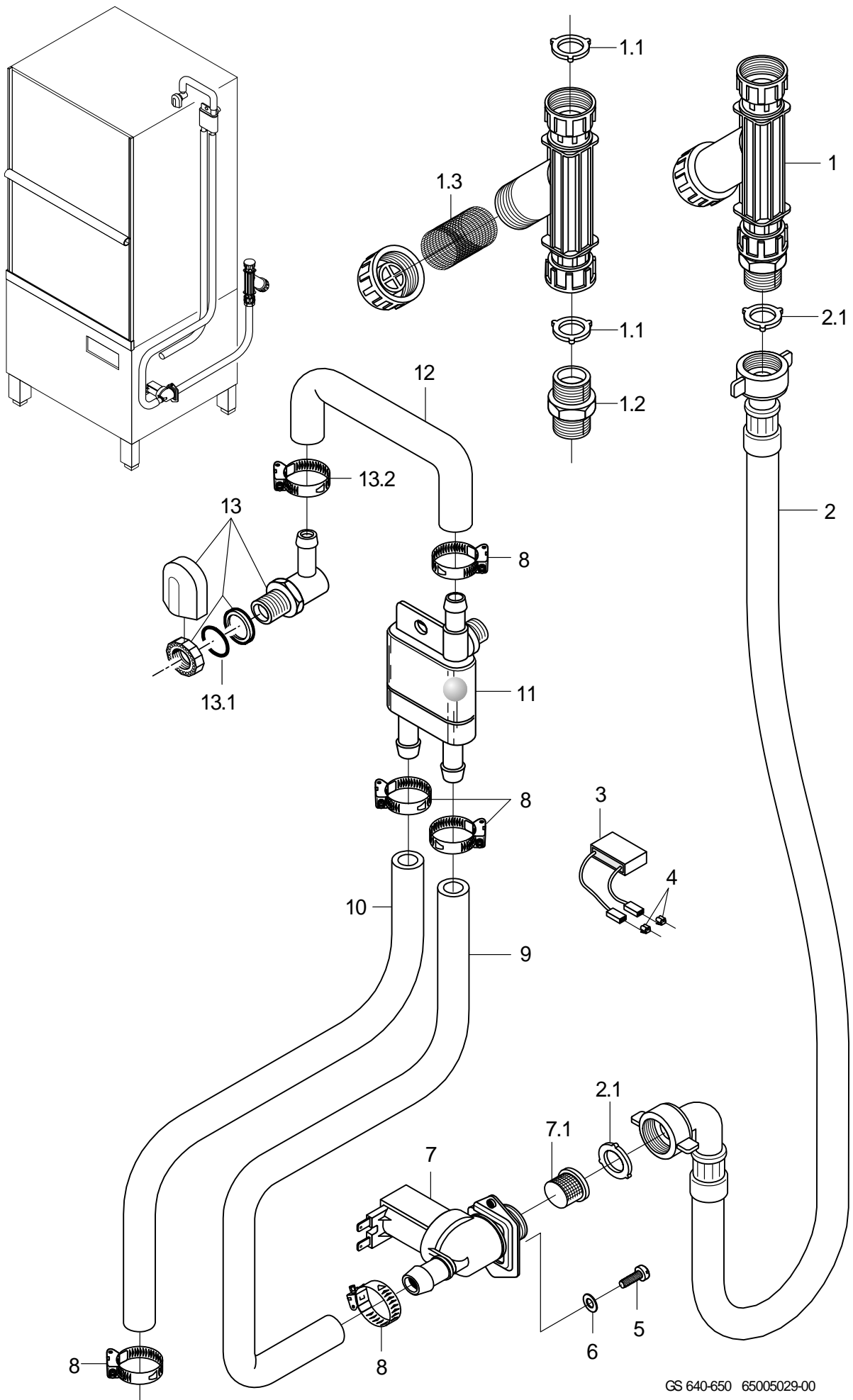

GS 640-650 65005029-00

GS 640 / GS 650

Water inlet GS 640: ...814 318; GS 650: ...813 826

Item.	Designation	Parts no.	Pc.	Notes
1	Dirt trap; 150 MICROMETER	80002153		incl. item 1.1 – 1.3
1.1	Gasket; D16 X D24 X 3,0	83001022	2	
1.2	DOUBLE NIPPLE; G 3/4" X 40; SW30	80002167		
1.3	Strainer; D27 X 67 X 150 MICROMETER	80002728		
2	WATER SUPPLY HOSE; DN13 X 3,5; 2500	40 02 060		incl. item 2.1
2.1	Gasket; D16 X D24 X 3,0	83001022	2	
3	RC element; 0,15 MICRO F; 3,3 KOHM	31 13 114		only with Aquamatik; parallel to item 7 connect
4	Flat plug; 6,3 X 0,8	31 12 018	2	only with Aquamatik; parallel to item 7 connect
5	Countersunk screw; M4 X 8	20 10 309		
6	Washer; D4,3 X D12 X 1,0	22 05 300		
7	Solenoid valve flow restrictor 15l; 220-240V/50-60HZ	31 06 180		...801 742; Machines with pressurized boiler
7	15 l solenoid valve set; 200-240V/50-60HZ/+10%	60004148		...801 742; Japan; Pressure boiler
7	Solenoid valve flow restrictor 5l; 220-240V/50-60HZ	31 06 174		...801 742; Pressure-independent boiler
7	Solenoid valve 5l; 200-240V/50-60HZ/+10%	60004147		...801 742; Japan; Pressure-independent boiler
7	Solenoid valve flow restrictor 15l; 230-240V 50/60HZ RAST5	31 06 214		801 743...; Machines with pressurized boiler
7	15 l solenoid valve set; 200-240V/50-60HZ/+10%	60004148		801 743...; Japan; Pressure boiler
7	Solenoid valve flow restrictor 5l; 230-240V 50/60HZ RAST5	31 06 215		801 743...; Pressure-independent boiler
7	Solenoid valve flow restrictor 5l; 200-208V 50/60HZ RAST5	31 06 213		801 743...; Japan; Pressure-independent boiler
7.1	Solenoid valve filter	31 06 186		
8	Hose clamp; D12-22 X 9	30000711		
9	Industrial hose; DN13 X 3,5	40 02 035		2030 mm; "By-the-metre" goods GS 640
9	Industrial hose; DN13 X 3,5	40 02 035		2200 mm; "By-the-metre" goods GS 650
10	Industrial hose; DN13 X 3,5	40 02 035		1510 mm; "By-the-metre" goods GS 640
10	Industrial hose; DN13 X 3,5	40 02 035		1680 mm; "By-the-metre" goods GS 650
11	Reverse suction preventer, top; PN6 BEI 60 GRAD C	35 01 193		
12	Hose bend; DN13 X 4,0	40 03 053		
13	Water inlet, 3-part set	55 31 007		incl. item 13.1 - 13.2
13.1	Gasket; D21 X D28 X 2,0	27 09 011		replaced by 55 31 007
13.1	Gasket; D20,5 X D28,5 X 2,0	27 01 002		replaced by 55 31 007
13.1	O-ring; 20 X 3	27 07 031		
13.2	Hose clamp; D12-22 X 9	30000711		

GS 640: 814319 ...
GS 650: 813827 ...

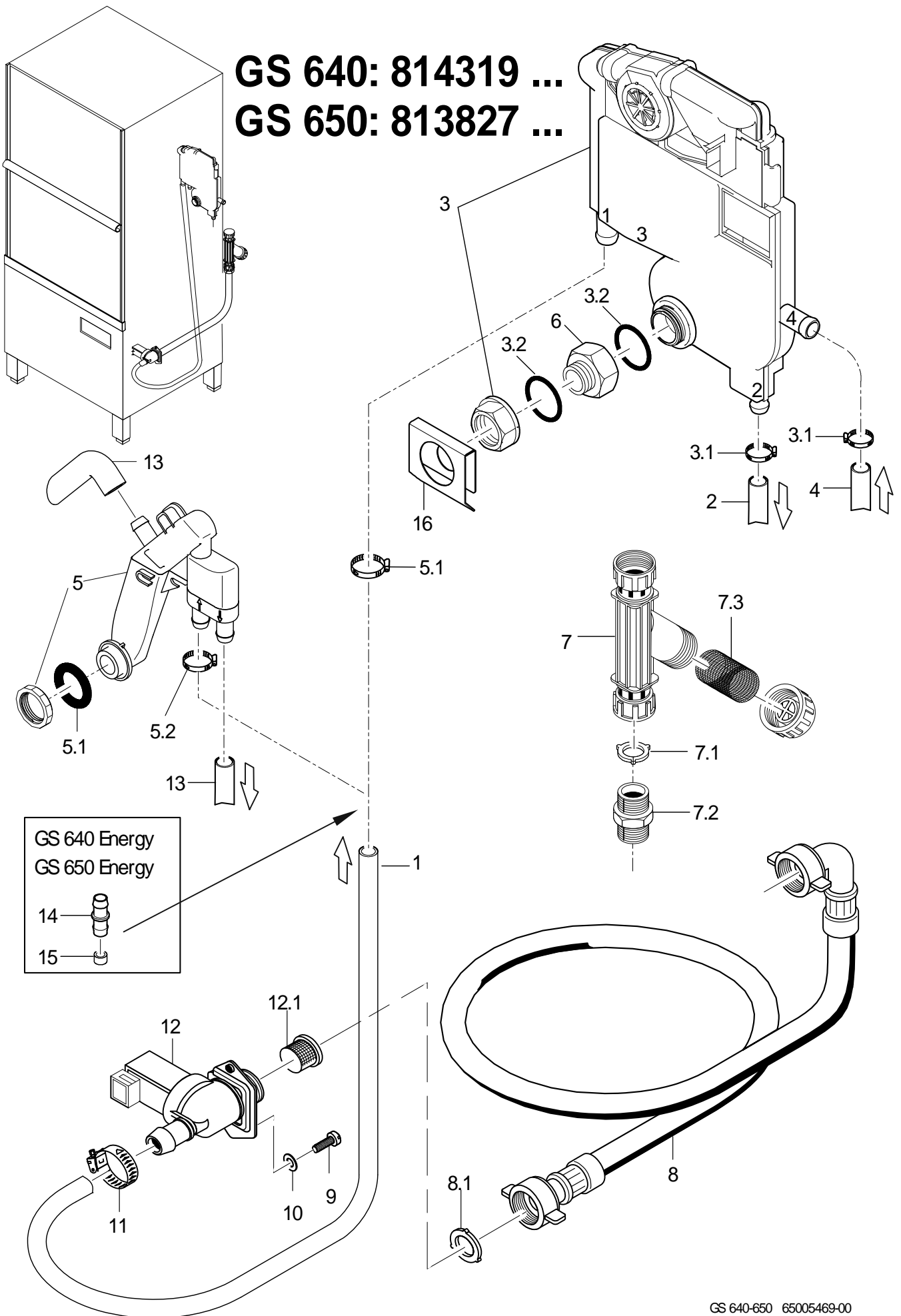

GS 640-650 65005469-00

GS 640 / GS 650

Water inlet GS 640: 814 319...; GS 650: 813 827...

Item.	Designation	Parts no.	Pc.	Notes
1	Industrial hose; DN13 X 3,5	40 02 035		1780 mm; "By-the-metre" goods
2	Reducing hose; DN10 X DN13; 55 X 1090	65005358		
3	WSE WITH IMPELLER COUNTER KIT	60003512		
3.1	Hose clamp; D12-22 X 9	30000711	4	
3.2	O-ring; 24 X 3,0	27 07 087		
3.3	Round cap; D11 X 20	35 03 029		
4	Hose elbow 90°; DN12,5X4,0;40X1400	60001610		
5	Kit airflow preventer	60003846		
5	CONVERSION WSE TO BACKFLOW PREVENTER	61006616		up to machine no.: 830 306; Replacement for WSE set (pos. 3), not for UK and Australia
5.1	O-ring; 24 X 3,0	27 07 087		
5.1	Hose clamp; D12-22 X 9	30000711		
6	Extension piece; D20 X 21; SW36	61005911		up to machine no.: 829 991
7	Dirt trap; 150 MICROMETER	80002153		incl. item 7.1 – 7.3
7.1	Gasket; D16 X D24 X 3,0	83001022		
7.2	DOUBLE NIPPLE; G 3/4" X 40; SW30	80002167		
7.3	Strainer; D27 X 67 X 150 MICROMETER	80002728		
8	WATER SUPPLY HOSE; DN13 X 3,5; 2500	40 02 060		incl. item 8.1
8.1	Gasket; D16 X D24 X 3,0	83001022	2	
9	Countersunk screw; M4 X 8	20 10 309	2	
10	Washer; D4,3 X D12 X 1,0	22 05 300	2	
11	Hose clamp; D12-22 X 9	30000711		
12	Solenoid valve flow restrictor 5l; 230-240V 50/60HZ RAST5	31 06 215		incl. item 12.1
12	Solenoid valve flow restrictor 5l; 200-208V 50/60HZ RAST5	31 06 213		Japan
12.1	Solenoid valve filter	31 06 186		
13	Hose elbow 90°; DN12,5X4,0;40X1400	60001610		adapt
14	Hose socket; D13 X D13	29 06 509		GS 640 + GS 650 Energy
15	Flow control; 3 L/MIN; VIOLETT	31 06 176		GS 640 + GS 650 Energy
16	Deflector plate	65005568		up to machine no.: 829 991

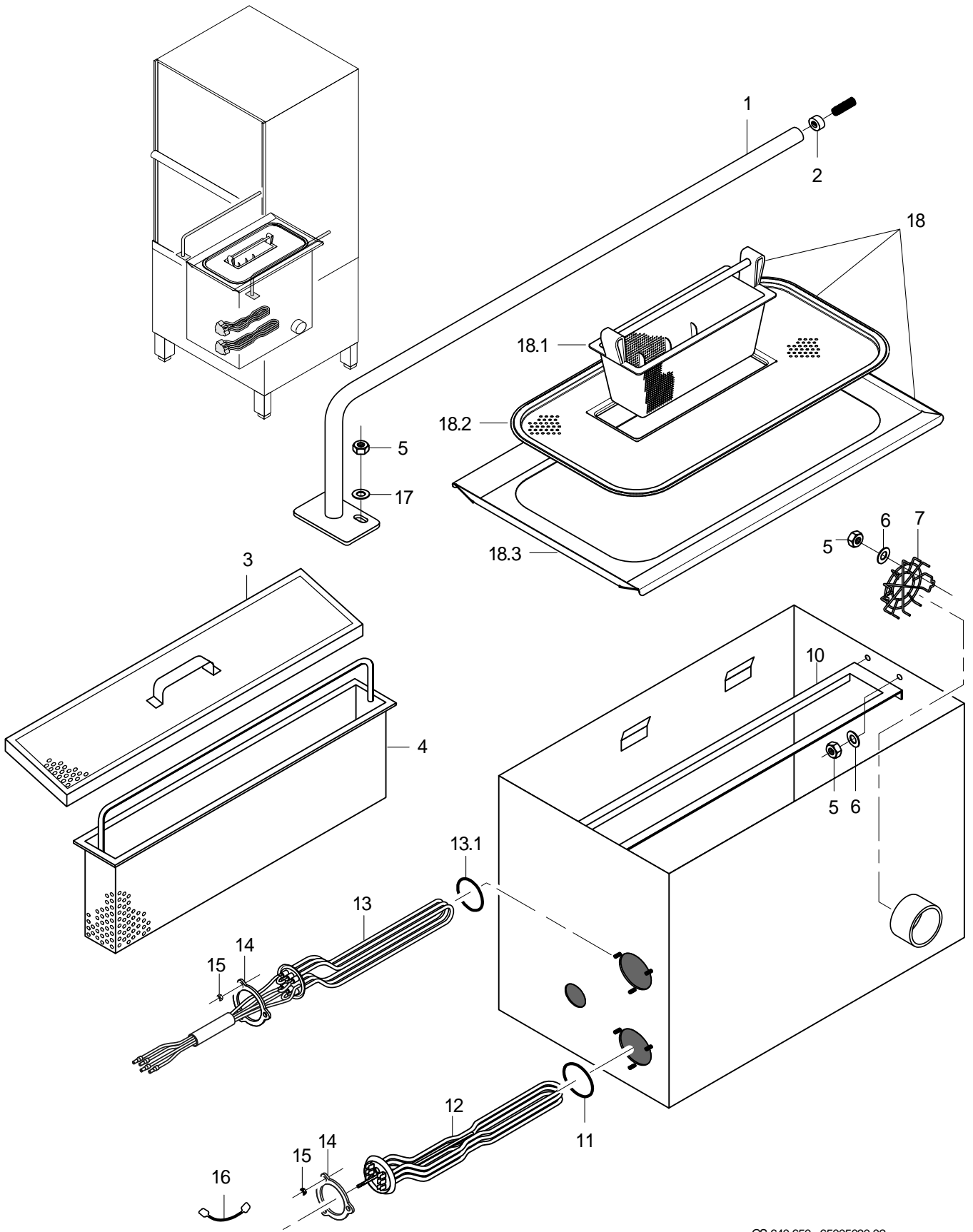

GS 640-650 65005030-02

GS 640 / GS 650

Tank and tank heating

Item.	Designation	Parts no.	Pc.	Notes
1	Rack carrier cpl.	65004213	2	
2	Roller; D18,9 X 20; M8	65004215	2	
3	Set exchange of flat filter	65005558	1	Replacement for: 65004092 (Flat filter)
4	Sump filter cpl.	65003029		up to machine no.: 827 715
5	Hexagonal nut self securing; M5	21 05 302		
6	Washer; D5,3 X D12 X 0,8	22 02 313		
7	Filter; D84 X D2 X 12	65004188		
10	Filter frame; 1,5 X 118 X 672,5	65004086		up to machine no.: 827 715
11	O-ring; 43 X 7,0	27 07 088	1	
12	Heating element cranked 6.0kW; 230V/400V/3	31 03 132		Slow start-up
12	Heating element cranked 6.0kW; 240V/420V/3	31 03 133		Slow start-up
12	Heating element cranked 6.0kW; 200V/346V/3	31 03 134		Slow start-up
12	Heating element cranked 6.0kW; 254V/440V/3	31 03 135		Slow start-up
13	Heating element, wash tank 9.0 kW with fuse; 400-440V, 3~, 9KW	30008054		
13	Heating element, wash tank 6.0 kW with fuse; 400-440V, 3~, 6KW	30008051		
13	Heating element, wash tank 6.0 kW with fuse; 200V, 3~, 6KW	30008053		
13	Heating element, wash tank 4,7/6,2 kW with fuse; 200V, 3~, 4,7KW/230V, 3~, 6,2KW	30008049		
13.1	O-ring; 43 X 7,0	27 07 088		
14	Locking washer; D43 X D80 X 4,0	01 17 003	2	
15	Hexagonal nut; M5	21 01 303		
16	Star bridge; 2,5QMM; 90 LG	70004616	3	
17	Washer; D5,3 X D15 X 1,2	22 05 301		
18	Set exchange of flat filter	65005558		from machine no.: 827 716
18.1	Filter cassette	61006262		
18.2	Strainer; 30 X 291 X 546	61004703		
18.3	Filter frame; 1,5 X 397,29 X 631,53	65005507		

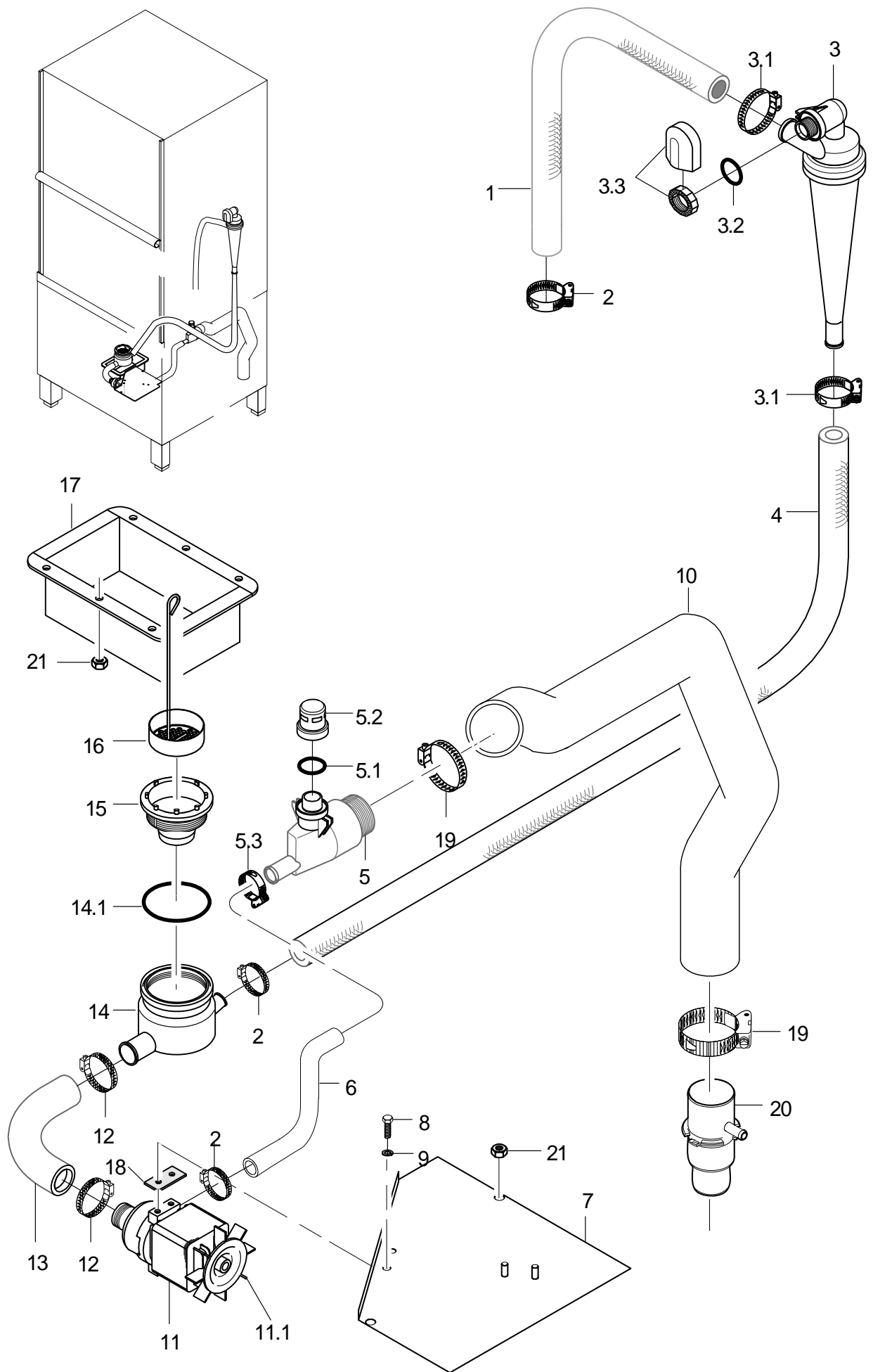

GS 640-650 65005031-01

GS 640 / GS 650

Water drain, Mediamat Cyclo

Item.	Designation	Parts no.	Pc.	Notes
1	Industrial hose; DN16 X 4,0	40 01 015		GS 640: up to mach. no. 814 318; 780 mm; "By-the-metre" goods
1	Industrial hose; DN16 X 4,0	40 01 015		GS 640: from mach. no. 814 319; 280 mm; "By-the-metre" goods
1	Industrial hose; DN16 X 4,0	40 01 015		GS 650: up to mach. no. 813 826; 950 mm; "By-the-metre" goods
1	Industrial hose; DN16 X 4,0	40 01 015		GS 650: from mach. no. 813 827; 280 mm; "By-the-metre" goods
2	Hose clamp; D20-30 X 12	28 02 109		
3	Mediamat Cyclo	61005184		incl. item 3.1 - 3.3
3.1	Hose clamp; D12-22 X 9	30000711	2	
3.2	O-ring; 20 X 3,5	27 07 040		
3.3	Tank inlet set; G 1/2" X 8; SW27	61005339		
4	Industrial hose; DN16 X 4,0	40 01 015		GS 640: up to mach. no. 814 318; 1460 mm; "By-the-metre" goods
4	Industrial hose; DN16 X 4,0	40 01 015		GS 640: from mach. no. 814 319; 1350 mm; "By-the-metre" goods
4	Industrial hose; DN16 X 4,0	40 01 015		GS 650: up to mach. no. 813 826; 1630 mm; "By-the-metre" goods
4	Industrial hose; DN16 X 4,0	40 01 015		GS 650: from mach. no. 813 827; 1350 mm; "By-the-metre" goods
5	Outlet	61005185		incl. item 5.1 – 5.3
5.1	O-ring; 29,5 X 4,5	27 07 008		
5.2	Cap; G 3/4" X 24; SW32	61004974		
5.3	Hose clamp; 25 - 40MM / 12MM	30002612		
6	Hose elbow; DN24X4,0;534X55	65004996		
7	Pump bracket cpl.	65004981		GS 640: up to mach. no. 814 318
7	Bracket cpl.	65005350		GS 640: from mach. no. 814 319
7	Pump bracket cpl.	65004981		GS 650: up to mach. no. 813 826
7	Bracket cpl.	65005350		GS 650: from mach. no. 813 827
8	Hexagon screw; M6 X 10; A70	30002732	2	
9	Spring washer; B6	23 03 300	2	
10	Drain hose kit; DN50 X 4	65005612		
11	3/0 lye pump; 200-240V/50-60HZ	31 02 410		incl. item 11.1
11.1	Fan blade	31 02 431		
12	Hose clamp; 25 - 40MM / 12MM	30002612	2	
13	Hose bend; DN24 X 4,0	61005028		
14	Sump pot	61005186		incl. item 14.1
14.1	O-ring; 91 X 3,5	27 07 075		
15	Sump drain set	61006178		
16	Sump filter; D70	65005555		
17	Trough; 1,5 X 401 X 655	65005021		
18	Spacer; 3,0 X 16 X 46	61005003		
19	Hose clamp; D50-70 x 12	30001243		
20	Double nipple; D51 X 124; D40	61006227		GS 640: from mach. no. 814 319
20	Double nipple; D51 X 124; D40	61006227		GS 650: from mach. no. 813 827
21	Hexagonal nut; M5	21 01 203	8	

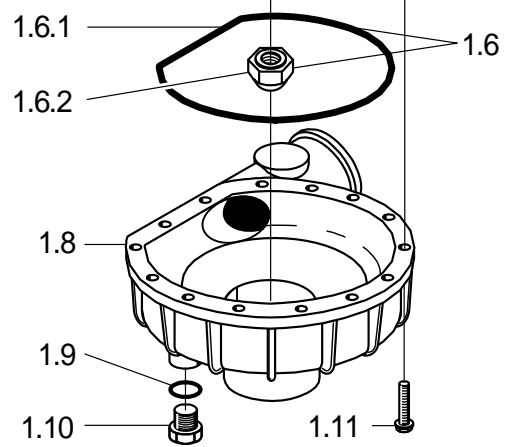
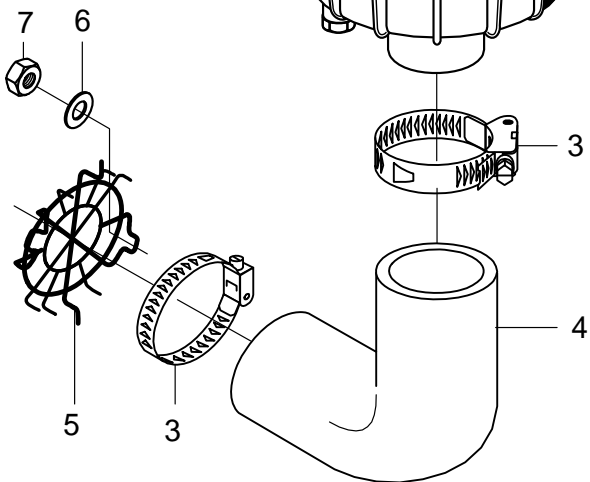
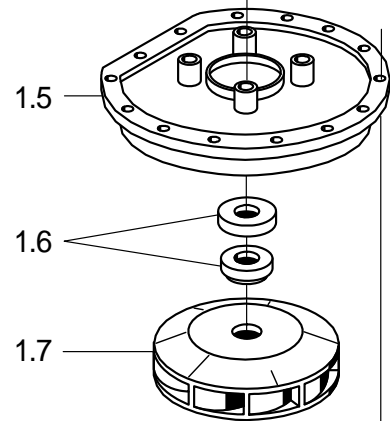
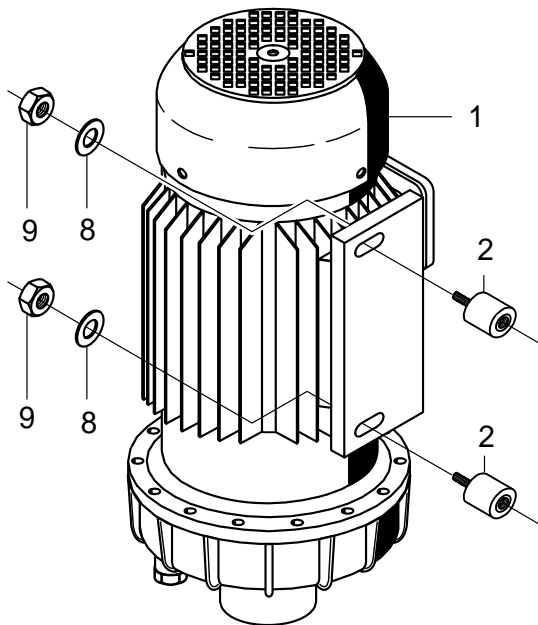
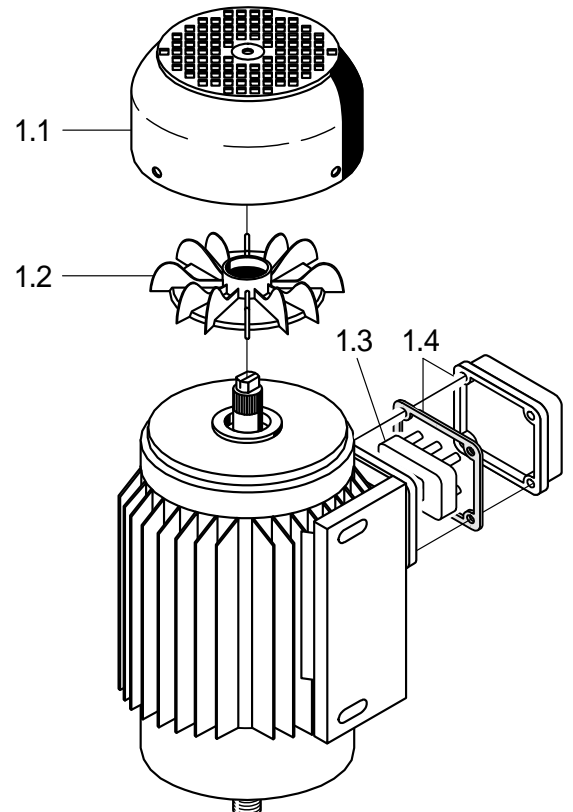
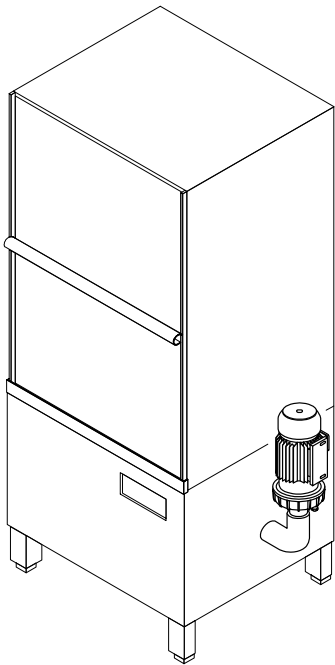

GS 640-650 65005032-00

GS 640 / GS 650

Wash pump

Item.	Designation	Parts no.	Pc.	Notes
1	1.85 kW 3/3 pump; 230V/400V/3/50HZ	31 02 573		incl. item 1.1 - 1.11
1	1.85 kW 3/3 pump; 230V/400V/3/60HZ	31 02 574		incl. item 1.1 - 1.11
1	1.85 kW 3/3 pump; 200V/346V/3/50HZ	31 02 575		incl. item 1.1 - 1.11
1	1.85 kW 3/3 pump; 200V/346V/3/60HZ	31 02 576		incl. item 1.1 - 1.11
1	1.85 kW 3/3 pump; 254V/440V/3/60HZ	31 02 577		incl. item 1.1 - 1.11
1.1	Fan cover	31 02 212		
1.2	Fan blade	31 02 211		
1.3	Terminal plate; 6-POLIG (FIR-PUMPE)	31 02 225		
1.4	Terminal box with gasket	31 02 327		
1.5	Pump cover	31 02 208		
1.6	Gasket set; 1,1/1,7/1,85/0,73 KW	80002670		incl. item 1.6.1 - 1.6.2
1.6.1	O-ring; 158,35 X 3,53	31 02 209		
1.6.2	Dome head nut; M8	21 10 305		
1.7	Pump impeller; D119; 1,85KW; 50HZ	31 02 407		for 50 Hz pumps
1.7	Pump impeller; D100; 1,85KW; 60HZ	31 02 408		for 60 Hz pumps
1.8	Pump housing	31 02 204		
1.9	O-ring; 20 X 3,5	27 07 040	2	
1.10	Dummy plug; G 1/2" X 20,5	35 01 108	2	
1.11	Hexagon screw; M4 X 25; 8.8	20 01 020		
2	Buffer; D30 X 25	40 06 022	2	
3	Hose clamp; 70 - 90MM / 12MM	30002614	2	
4	Hose elbow; DN62 X 7,0	65004103		
5	Filter; D84 X D2 X 12	65004188		
6	Washer; D5,3 X D12 X 0,8	22 02 313		
7	Hexagonal nut self securing; M5	21 05 302		
8	Washer; D8,4 X D17 X 1,6	22 01 303		
9	Hexagonal nut; M8	21 01 305		

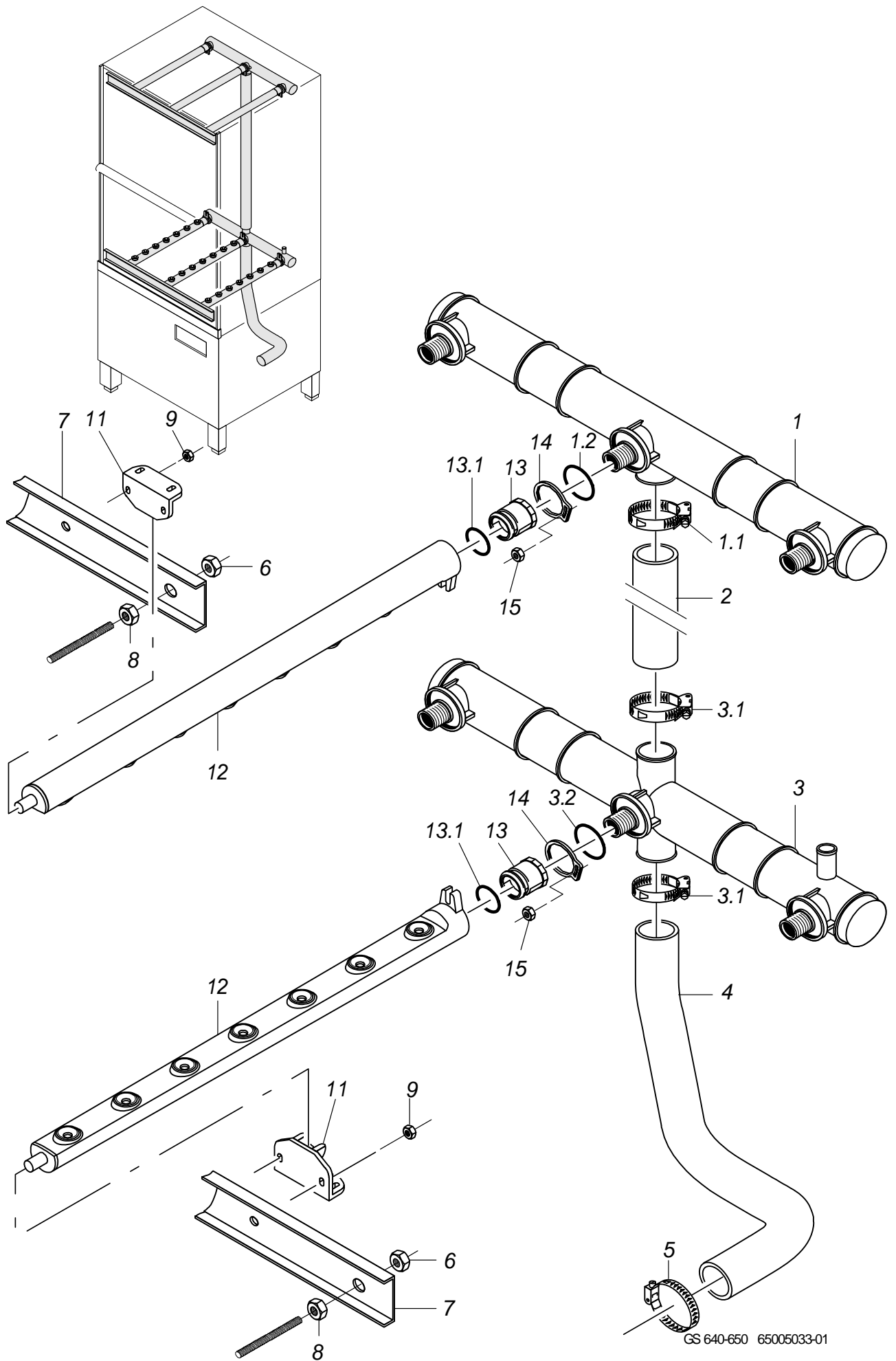

GS 640 / GS 650

Wash system

Item.	Designation	Parts no.	Pc.	Notes
1	Top wash distributor cpl.	65004824		incl. item 1.1 - 1.2
1.1	Hose clamp; D50-70 x 12	30001243		
1.2	O-ring; 29,5 X 4,5	27 07 008	3	
2	Industrial hose; DN50 X 6,0	40 02 006		755 mm; "By-the-metre" goods GS 640
2	Industrial hose; DN50 X 6,0	40 02 006		925 mm; "By-the-metre" goods GS 650
3	Bottom wash distributor cpl.	65004825		incl. item 3.1 - 3.2
3.1	Hose clamp; D50-70 x 12	30001243	2	
3.2	O-ring; 29,5 X 4,5	27 07 008	3	
4	Hose bend; DN50 X 6,0	65004151		
5	Hose clamp; D50-70 x 12	30001243		
6	Hexagonal nut; M8	21 05 306		
7	Wash arm support cpl.	65004014	2	
8	Hexagonal nut; M8	21 01 305		
9	Ratchet nut; M5	21 01 310	6	
11	Snap fit short; 29 X 32 X 64	60002524	6	
12	Wash arm cpl.; 7 DÜSEN	65004997	6	
13	Locking nut cpl.	65005484	6	incl. item 13.1
13.1	Seal ring; D26 X D32,5 X 5,0	70009122		
14	Setting washer; 5,0 X 40 X 50	60002540	6	
15	Self-locking nut with serrated surface; M4	21 01 313	6	

GS 40: ... 814318

GS 650: ... 813826

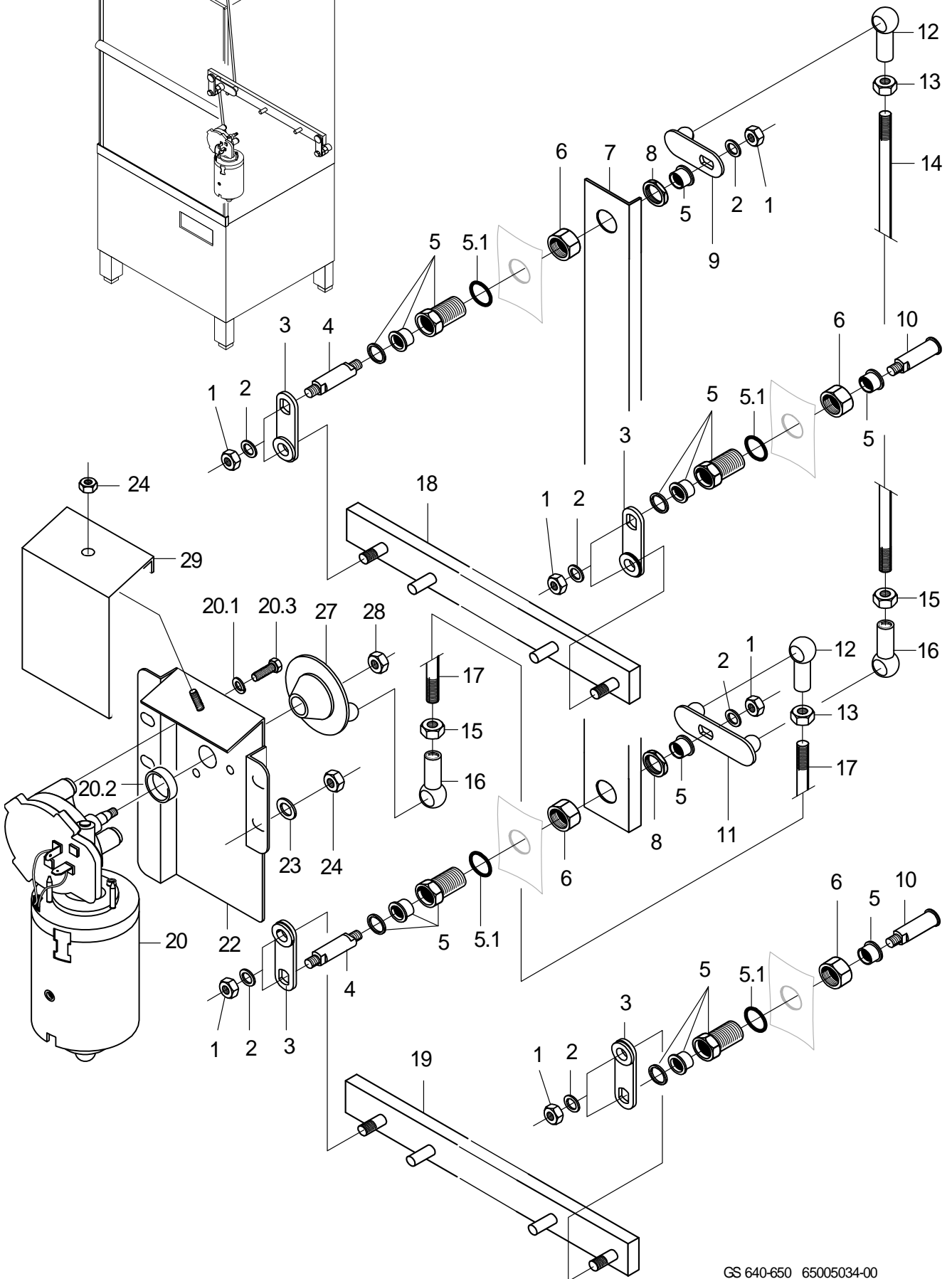

GS 640-650 65005034-00

GS 640 / GS 650

Reversing GS 640: ...814 318; GS 650: ...813 826

Item.	Designation	Parts no.	Pc.	Notes
o.P.	Reversal wiring loom; 2 X 0,75QMM	65005013		
1	Hexagonal nut; M6	21 05 304		
2	Washer; D6,4 X D18 X 1,6	22 05 302		
3	Reversing lever	61006181	4	
4	Reversing shaft; D12 X 66,6	60002385	2	
5	Bearing bush cpl.	65004835	4	incl. item 5.1
5.1	O-ring; 26 X 2,5	27 07 062		
6	Hexagonal nut; G 3/4" X 10,0; SW36	30 09 209	4	
7	Elbow; 1,5 X 57 X 863	65004323		GS 640
7	Elbow; 1,5 X 57 X 1034	65003002		GS 650
8	Hex nut; G 3/4" X 5,0; SW32	61002626	2	
9	Lever	60002391		
10	Reversing axle; D15 X 57,3	60002384	2	
11	Lever	65003803		
12	Ball socket right; M8	28 05 500	2	
13	Hexagonal nut; M8	21 01 305		
14	Threaded rod; M8 X 775	65004047		GS 640
14	Threaded rod; M8 X 952	65003807		GS 650
15	Hexagonal nut; M8 LH	21 01 001		Left-hand thread
16	Ball socket left; M8-LH	28 05 501	2	Left-hand thread
17	Threaded rod; M8 X 180	65003806		
18	Top connecting rod cpl.	65004132		
19	Connecting rod cpl.	65003987		
20	Geared motor set	61006607		
20.1	Spring washer; B6	23 03 300		
20.2	Radial shaft seal; D9,7 X D18 X 6	27 10 022		
20.3	Hexagon screw; M6 X 16; A70	20 01 306		
22	Bracket; 2,0 X 164 X 255,23	65004799		
23	Washer; D5,3 X D12 X 0,8	22 02 313		
24	Hexagonal nut self securing; M5	21 05 302		
27	Crank disk cpl.	60001297		
28	Hexagonal nut; M8	21 05 306		
29	Guard plate; 1,0 X 98 X 217,4	65004801		

GS 640: 813827 ...

GS 650: 813827 ...

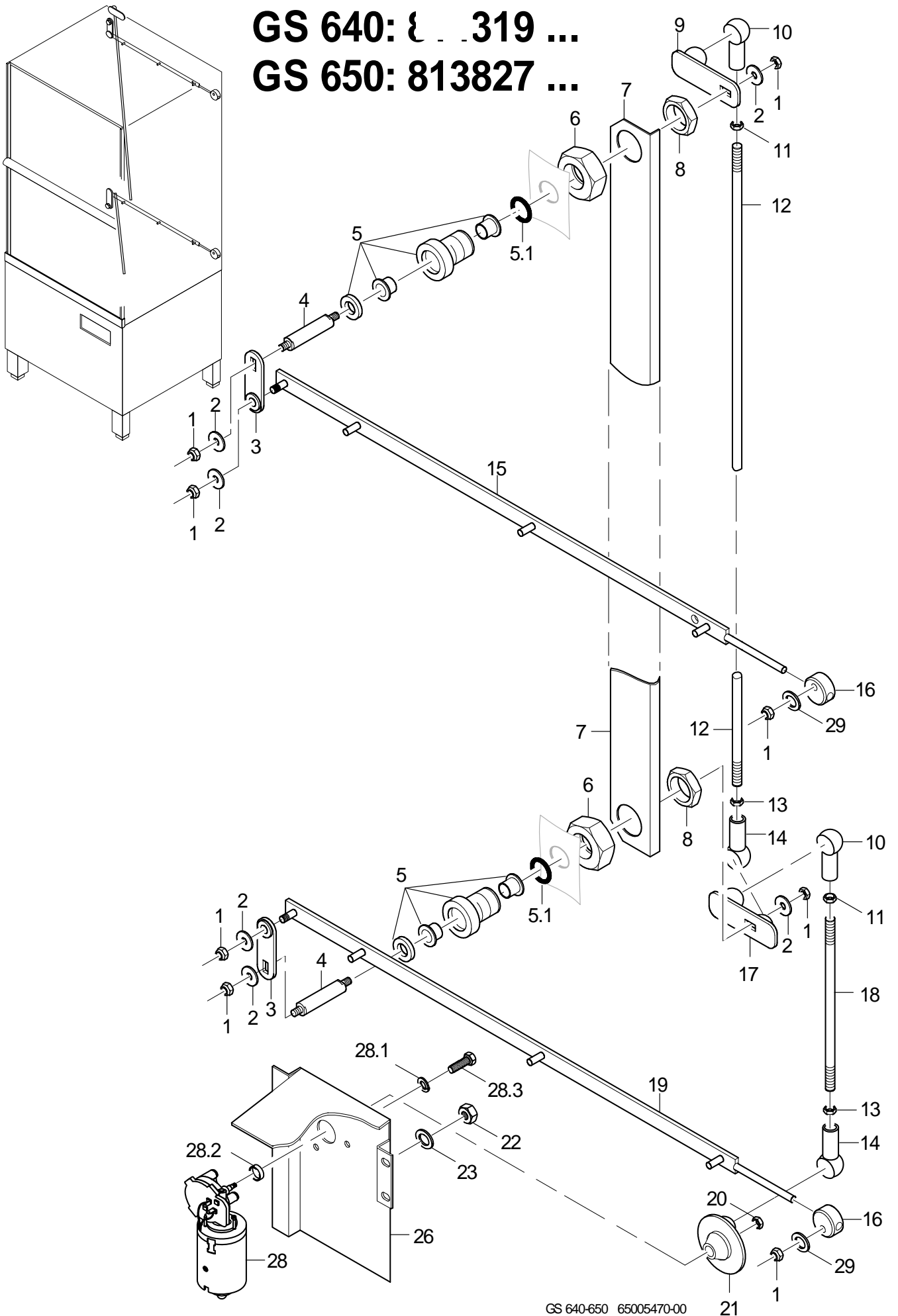

GS 640-650 65005470-00

GS 640 / GS 650

Reversing GS 640: 814 319...; GS 650: 813 827...

Item.	Designation	Parts no.	Pc.	Notes
1	Hexagonal nut; M6	21 05 304	8	
2	Washer; D6,4 X D18 X 1,6	22 05 302	8	
3	Reversing lever	61006181	2	
4	Reversing shaft; D12 X 66,6	60002385	2	
5	Bearing bush cpl.	65004835	2	
5.1	O-ring; 26 X 2,5	27 07 062		
6	Hexagonal nut; G 3/4" X 10,0; SW36	30 09 209	2	
7	Elbow; 1,5 X 57 X 863	65004323		GS 640
7	Elbow; 1,5 X 57 X 1034	65003002		GS 650
8	Hex nut; G 3/4" X 5,0; SW32	61002626	2	
9	Lever	60002391		
10	Ball socket right; M8	28 05 500	2	
11	Hexagonal nut; M8	21 01 305	2	
12	Threaded rod; M8 X 775	65004047		GS 640
12	Threaded rod; M8 X 952	65003807		GS 650
13	Hexagonal nut; M8 LH	21 01 001	2	Left-hand thread
14	Ball socket left; M8-LH	28 05 501	2	Left-hand thread
15	Top connecting rod cpl.; 4,0 X 15 X 618,5	65005201		
16	Bearing; D26 X 12	61005648	2	
17	Lever	65003803		
18	Threaded rod; M8 X 180	65003806		
19	Bottom connecting rod; 4,0 X 15 X 618,5	65005203		
20	Hexagonal nut; M8	21 05 306		
21	Crank disk cpl.	60001297		
22	Hexagonal nut self securing; M5	21 05 302	4	
23	Washer; D5,3 X D12 X 0,8	22 02 313	4	
26	Bracket; 2,0 X 164 X 255,23	65004799		
28	Geared motor set	61006607		
28.1	Spring washer; B6	23 03 300	3	
28.2	Radial shaft seal; D9,7 X D18 X 6	27 10 022		
28.3	Hexagon screw; M6 X 16; A70	20 01 306	3	
29	Washer; D6,4 X D12,5 X 1,6	22 01 302	2	

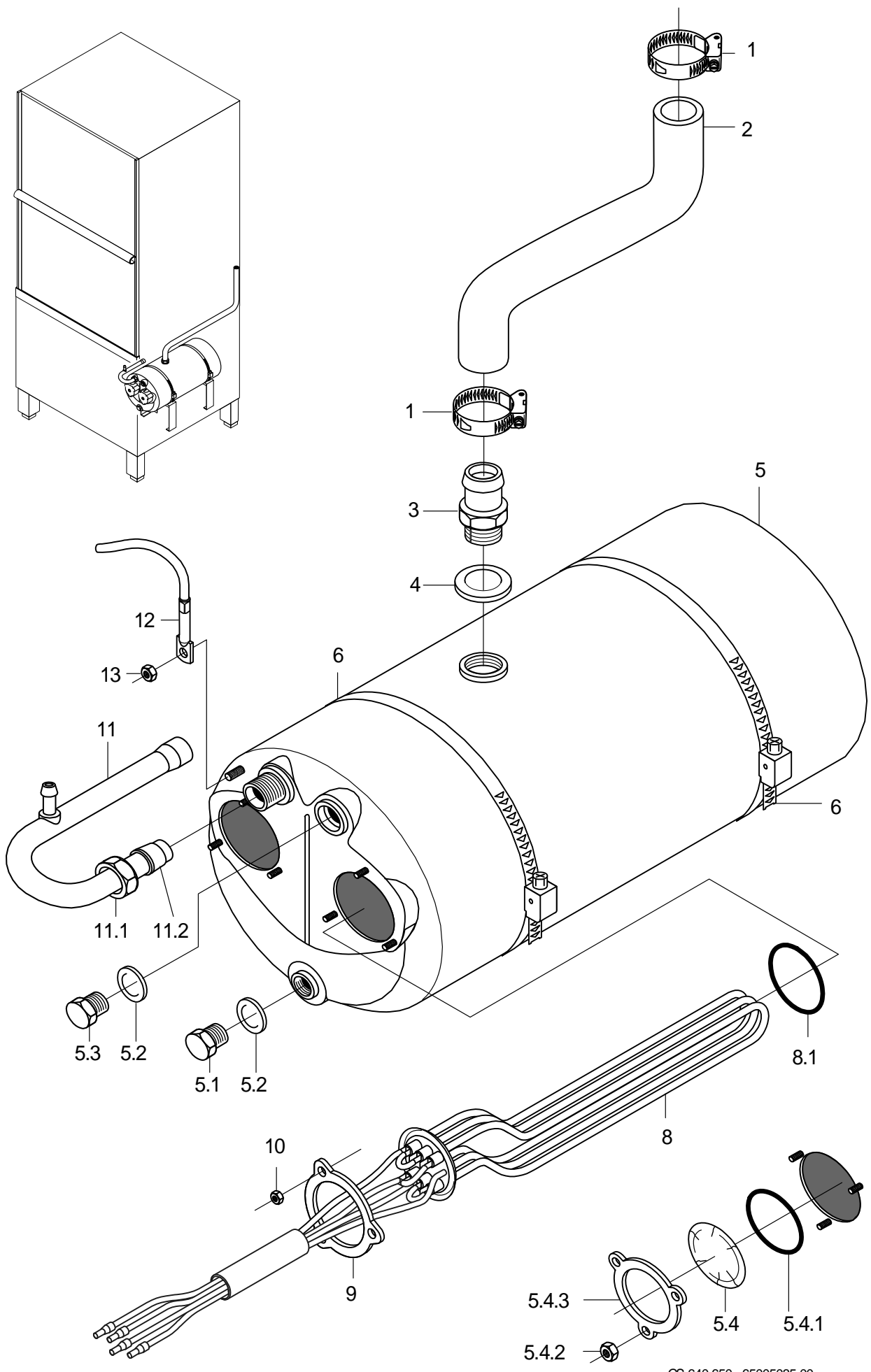

GS 640-650 65005035-00

GS 640 / GS 650

Pressure boiler GS 640: ...814 318; GS 650: ...813 826

Item.	Designation	Parts no.	Pc.	Notes
1	Hose clamp; D24-44 X 12	28 02 309		
2	Hose bend; DN25 X 4,0	65004182		
3	Hose nipple; D26 X 41; G 1/2"; SW27	80001403		
4	Gasket; D21 X D28 X 2,0	27 09 011		
5	Boiler cpl., 2-hole; 12 KW; 480 LG	55 12 032		incl. item 5.1 - 5.4
5.1	Hexagon screw; M10 X 16; A70	20 01 352		
5.2	Gasket; D10 X D18 X 1,5	27 03 003		
5.3	Locking screw; M9 X 1 X 14	70003890		
5.4	Blind flange	60002787		incl. item 5.4.1 - 5.4.3
5.4.1	O-ring; 43 X 7,0	27 07 088		
5.4.2	Hexagonal nut; M5	21 01 203	3	
5.4.3	Locking washer; D43 X D80 X 4,0	01 17 003		
6	Hose clamp; D50-215 X 12	28 02 126		
8	Heating element, boiler 6.0 kW with fuse; 400-440V, 3~, 6KW	30008044		
8	Heating element, boiler 9.0 kW with fuse; 400-440V, 3~, 9KW	30008047		
8	Heating element, boiler 6.0 kW with fuse; 400-440V, 3~, 6KW	30008045		Australia
8	Heating element, boiler 6.0 kW with fuse; 200V, 3~, 6KW	30008046		
8	Heating element, boiler 3.0 kW with fuse; 200V, 3~, 3KW	30008042		
8	Heating element, boiler 6.0 kW with fuse; 230V, 3~, 6KW	30008050		
8	Heating element, boiler 3.0 kW with fuse; 230V, 3~, 3KW	30008043		
8.1	O-ring; 43 X 7,0	27 07 088		
9	Locking washer; D43 X D80 X 4,0	01 17 003		
10	Hexagonal nut; M5	21 01 203		
11	Boiler inlet elbow, cpl.	55 09 054		incl. item 11.1 - 11.2
11.1	Coupling nut; G 1/2" X D12,2; SW24	29 07 201		
11.2	Cutting ring; D12 X 10	29 07 300		
12	Thermal sensor kit 1000mm	80003803		with heat-conducting foil
13	Ratchet nut; M5	21 01 310		

GS 640: ... 814318
GS 650: ... 813826

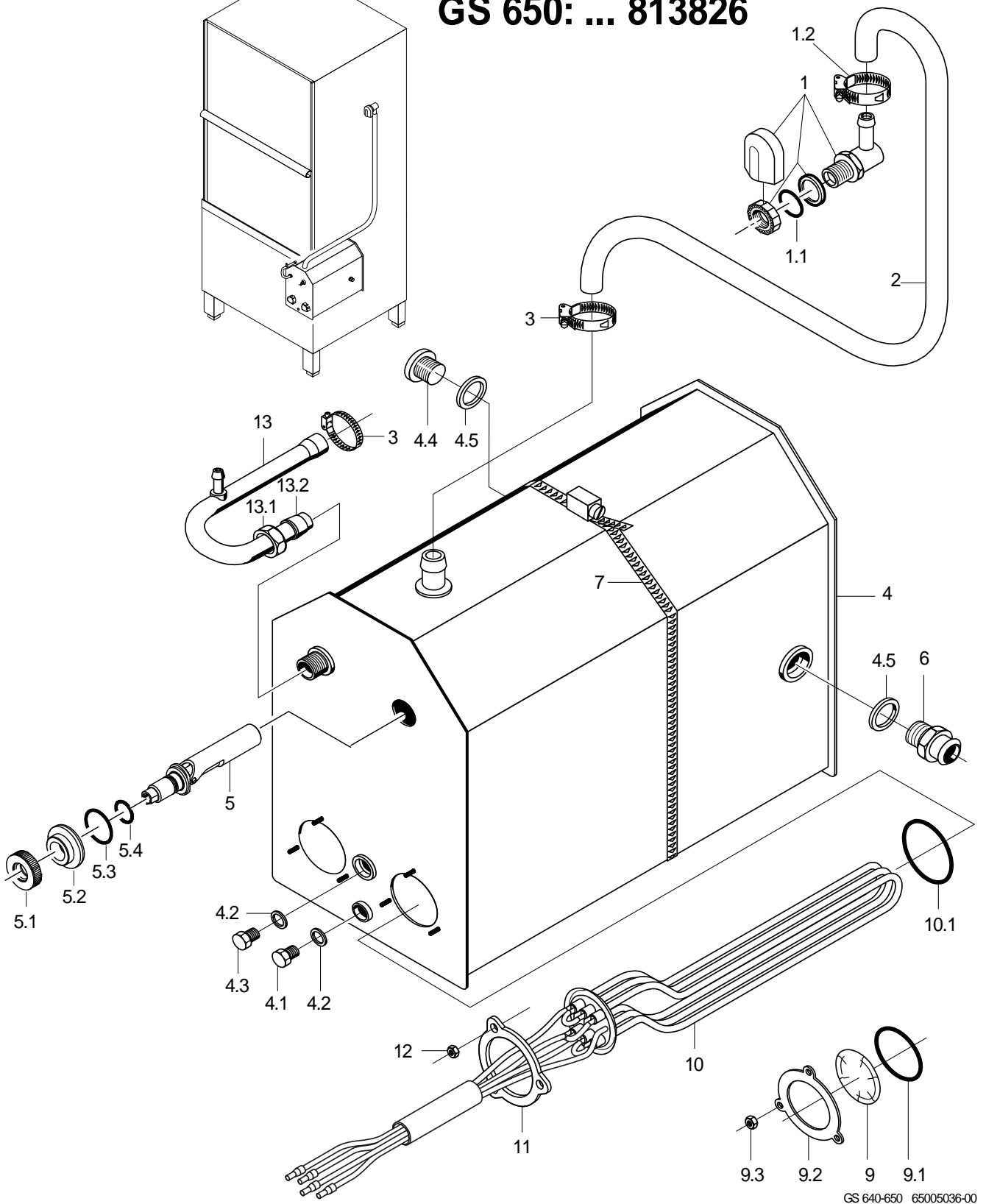

GS 640-650 65005036-00

GS 640 / GS 650

Pressure-independent boiler GS 640: ...814 318; GS 650: ...813 826

Item.	Designation	Parts no.	Pc.	Notes
1	Water inlet, 3-part set	55 31 007		incl. item 1.1 - 1.2
1.1	Gasket; D21 X D28 X 2,0	27 09 011		replaced by 55 31 007
1.1	Gasket; D20,5 X D28,5 X 2,0	27 01 002		replaced by 55 31 007
1.1	O-ring; 20 X 3	27 07 031		
1.2	Hose clamp; D12-22 X 9	30000711		
2	Hose bend; DN12,5 X 4,0	40 03 056		adapt
3	Hose clamp; D12-22 X 9	30000711		
4	Pressureless boiler cpl.	80002128		incl. item 4.1 - 4.5
4.1	Hexagon screw; M10 X 16; A70	20 01 352		
4.2	Gasket; D10 X D18 X 1,5	27 03 003		
4.3	Locking screw; M9 X 1 X 14	70003890		
4.4	Screw plug; G 1/2"	30 08 303		
4.5	Gasket; D21 X D28 X 2,0	27 09 011	2	
5	Floating switch installation set	55 28 255		incl. item 5.1 - 5.4
5.1	Nut; M14 X 2, D26,8 X 8	60003989		
5.2	Ring; D14,3 X D32 X 11	60003872		
5.3	O-ring; 23 X 3,5	27 07 093		
5.4	O-ring; 11,11 X 1,78	27 07 079		
6	Hose nipple; D26 X 41; G 1/2"; SW27	80001403		
7	Hose clamp; D212-232 X 12	28 02 136		
9	Blind flange	60002787		incl. item 9.1 - 9.3
9.1	O-ring; 43 X 7,0	27 07 088		
9.2	Locking washer; D43 X D80 X 4,0	01 17 003		
9.3	Hexagonal nut; M5	21 01 203		
10	Heating element, boiler 6.0 kW with fuse; 400-440V, 3~, 6KW	30008044		
10	Heating element, boiler 9.0 kW with fuse; 400-440V, 3~, 9KW	30008047		
10	Heating element, boiler 6.0 kW with fuse; 400-440V, 3~, 6KW	30008045		Australia
10	Heating element, boiler 6.0 kW with fuse; 200V, 3~, 6KW	30008046		
10	Heating element, boiler 3.0 kW with fuse; 200V, 3~, 3KW	30008042		
10	Heating element, boiler 6.0 kW with fuse; 230V, 3~, 6KW	30008050		
10	Heating element, boiler 3.0 kW with fuse; 230V, 3~, 3KW	30008043		
10.1	O-ring; 43 X 7,0	27 07 088		
11	Locking washer; D43 X D80 X 4,0	01 17 003		
12	Hexagonal nut; M5	21 01 203		
13	Boiler inlet elbow, cpl.	55 09 054		incl. item 13.1 - 13.2
13.1	Coupling nut; G 1/2" X D12,2; SW24	29 07 201		
13.2	Cutting ring; D12 X 10	29 07 300		

GS 640: 814319 ...
GS 650: 813827 ...

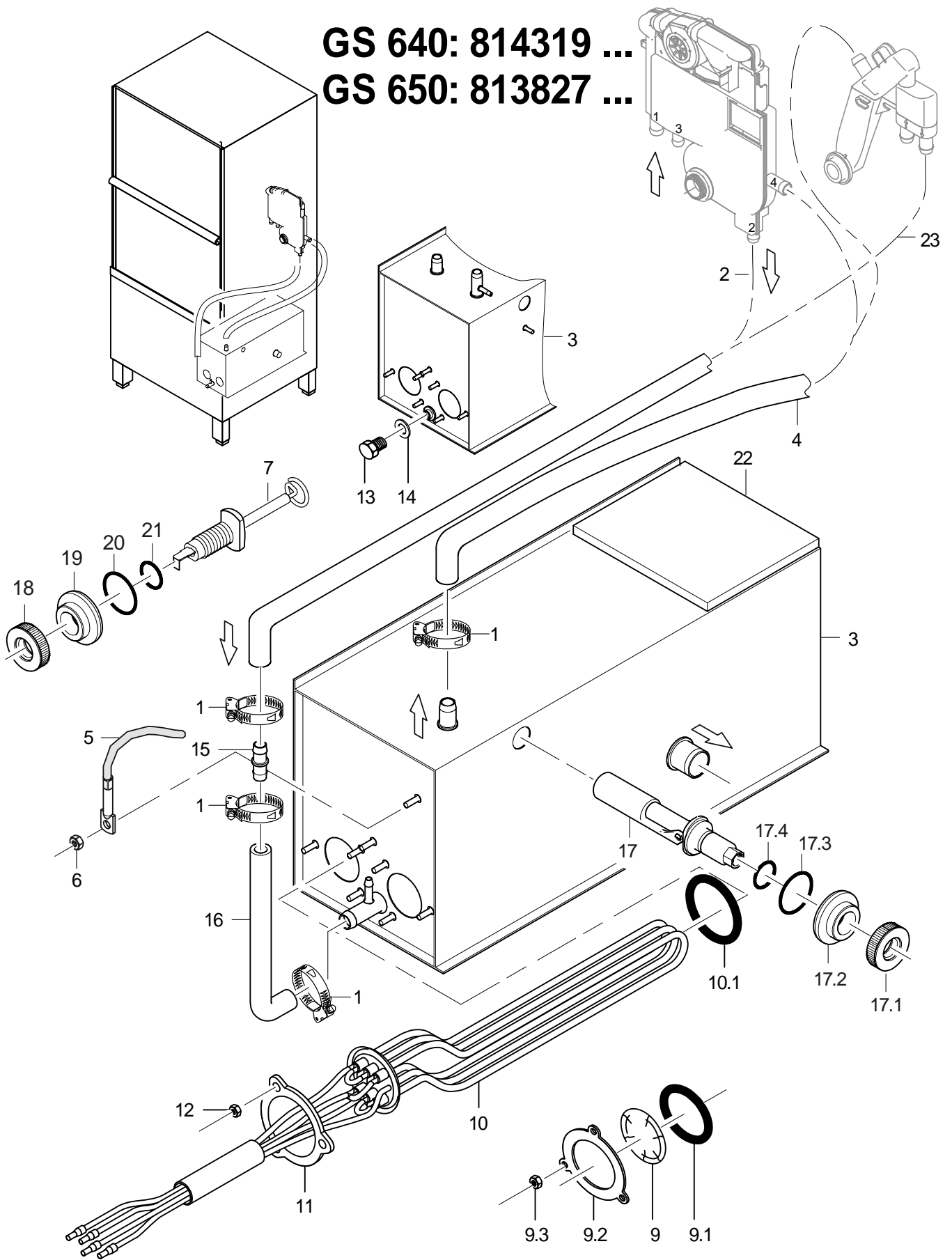

GS 640-650 65005471-02

GS 640 / GS 650

Pressure-independent boiler GS 640: 814 319...; GS 650: 813 827...

Item.	Designation	Parts no.	Pc.	Notes
1	Hose clamp; D12-22 X 9	30000711	2	
2	Reducing hose; DN10 X DN13; 55 X 1090	65005358		
3	Pressure-independent boiler	65005550		includes all necessary hoses
4	Hose elbow 90°; DN12,5X4,0;40X1400	60001610		
5	Thermal sensor kit 1000mm	80003803		with heat-conducting foil
6	Ratchet nut; M5	21 01 310		
7	Floating switch installation set	55 28 255		Replacement for: 5528292 (Built-in electrode)
7.1	Nut; M14 X 2, D26,8 X 8	60003989		incl. item 7.1 - 7.4
7.2	Ring; D14,3 X D32 X 11	60003872		
7.3	O-ring; 23 X 3,5	27 07 093		
7.4	O-ring; 11,11 X 1,78	27 07 079		
9	Blind flange	60002787		incl. item 9.1 – 9.3
9.1	O-ring; 43 X 7,0	27 07 088		
9.2	Locking washer; D43 X D80 X 4,0	01 17 003		
9.3	Hexagonal nut; M5	21 01 203	3	
10	Heating element, boiler 6.0 kW with fuse; 400-440V, 3~, 6KW	30008044		
10	Heating element, boiler 9.0 kW with fuse; 400-440V, 3~, 9KW	30008047		
10	Heating element, boiler 6.0 kW with fuse; 400-440V, 3~, 6KW	30008045		Australia
10	Heating element, boiler 6.0 kW with fuse; 230V, 3~, 6KW	30008050		
10	Heating element, boiler 3.0 kW with fuse; 230V, 3~, 3KW	30008043		
10	Heating element, boiler 6.0 kW with fuse; 200V, 3~, 6KW	30008046		
10	Heating element, boiler 3.0 kW with fuse; 200V, 3~, 3KW	30008042		
10.1	O-ring; 43 X 7,0	27 07 088		
11	Locking washer; D43 X D80 X 4,0	01 17 003		
12	Hexagonal nut; M5	21 01 203	3	
13	Hexagon screw; M10 X 16; A70	20 01 352		
14	Gasket; D10 X D18 X 1,5	27 03 003		
15	Hose socket; D13 X D13	29 06 509		
16	Hose elbow 90°; DN12,5 X 4,0; 40 X 200	65005547		
17	Floating switch installation set	55 28 255		
17.1	Nut; M14 X 2, D26,8 X 8	60003989		
17.2	Ring; D14,3 X D32 X 11	60003943		
17.3	O-ring; 23 X 3,5	27 07 093		
17.4	O-ring; 11,11 X 1,78	27 07 079		
18	Nut; M14 X 2, D26,8 X 8	60003989		
19	Ring; D14,3 X D32 X 11	60003943		
20	O-ring; 24 X 3,0	27 07 087		
21	O-ring; 11,11 X 1,78	27 07 079		
22	Insulating board; 10 X 150 X 180	65005554		
23	Hose elbow 90°; DN12,5X4,0;40X1400	60001610		

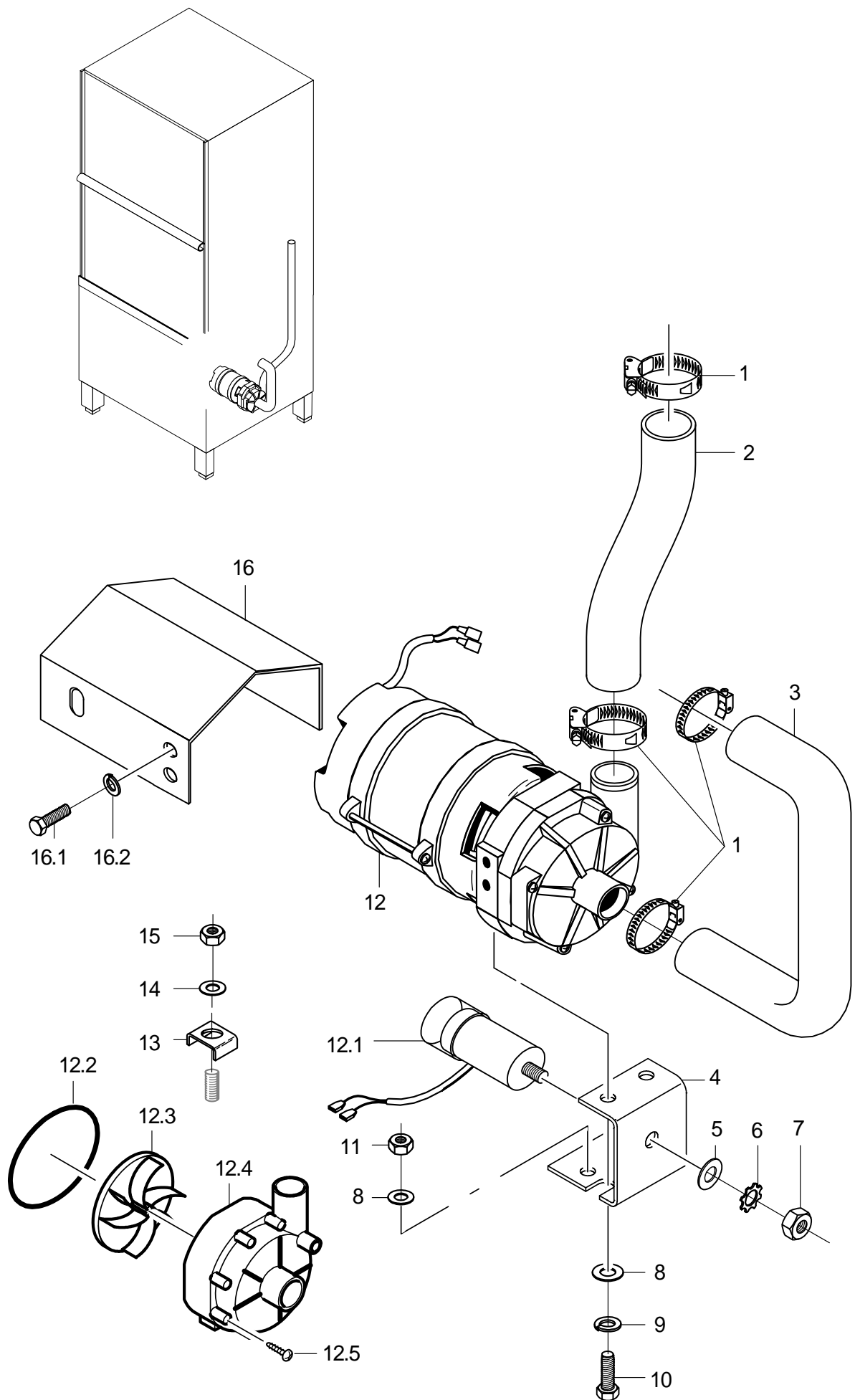

GS 640-650 65005037-00

GS 640 / GS 650

Rinse pump

Item.	Designation	Parts no.	Pc.	Notes
1	Hose clamp; 25 - 40MM / 12MM	30002612	2	
2	Hose elbow 90°; DN26X4;333,5X613,5	65005108		
3	Hose elbow; DN22 X 5,5	65004027		
4	Pump holder; 2,0 X 45 X 111,57	80001482		
5	Washer; D8,4 X D17 X 1,6	22 01 303		
6	Spring washer; B8	23 03 301		
7	Hexagonal nut; M8	21 01 305		
8	Washer; D5,3 X D12 X 0,8	22 02 313		
9	Spring washer; B6	23 03 300		
10	Hexagon screw; M6 X 16; A70	20 01 306		
11	Hexagonal nut self securing; M5	21 05 302		
12	Pump 0.270 kW 8/0; 220/240V/1/50HZ	31 02 477		Repair recommended only for pump housings with 7 screws
12	Pump 0.270 kW 8/0; 220/240V/1/60HZ	31 02 445		Repair recommended only for pump housings with 7 screws
12	Pump 0.270 kW 8/0; 200V/1/50HZ	31 02 446		Repair recommended only for pump housings with 7 screws
12	Pump 0.270 kW 8/0; 200V/1/60HZ	31 02 447		Repair recommended only for pump housings with 7 screws
12.1	Capacitor; 5 MIKRO F	31 13 099		
12.2	Cord; D=78 X 3; SHOR 50-55;	40 04 023		
12.3	Pump impeller with counter ring; UP60/UP30 - 50HZ	31 02 466		50 Hz
12.3	Pump impeller, installed; FÜR UP60 MIT 60HZ	31 02 587		60 Hz
12.4	Pump housing; D=80,5MM	31 02 519		
12.5	Screw for pump housing; D4X35 PT	31 01 118	7	
13	Hexagon screw; M6 X 16; A70	20 01 306		
14	Washer; D6,4 X D12,5 X 1,6	22 01 302		
15	Hexagonal nut; M6	21 01 304		
16	Guard plate	80002255		incl. item 16.1 – 16.2
16.1	Hexagon screw; M6 X 16; A70	20 01 306		
16.2	Spring washer; B6	23 03 300		

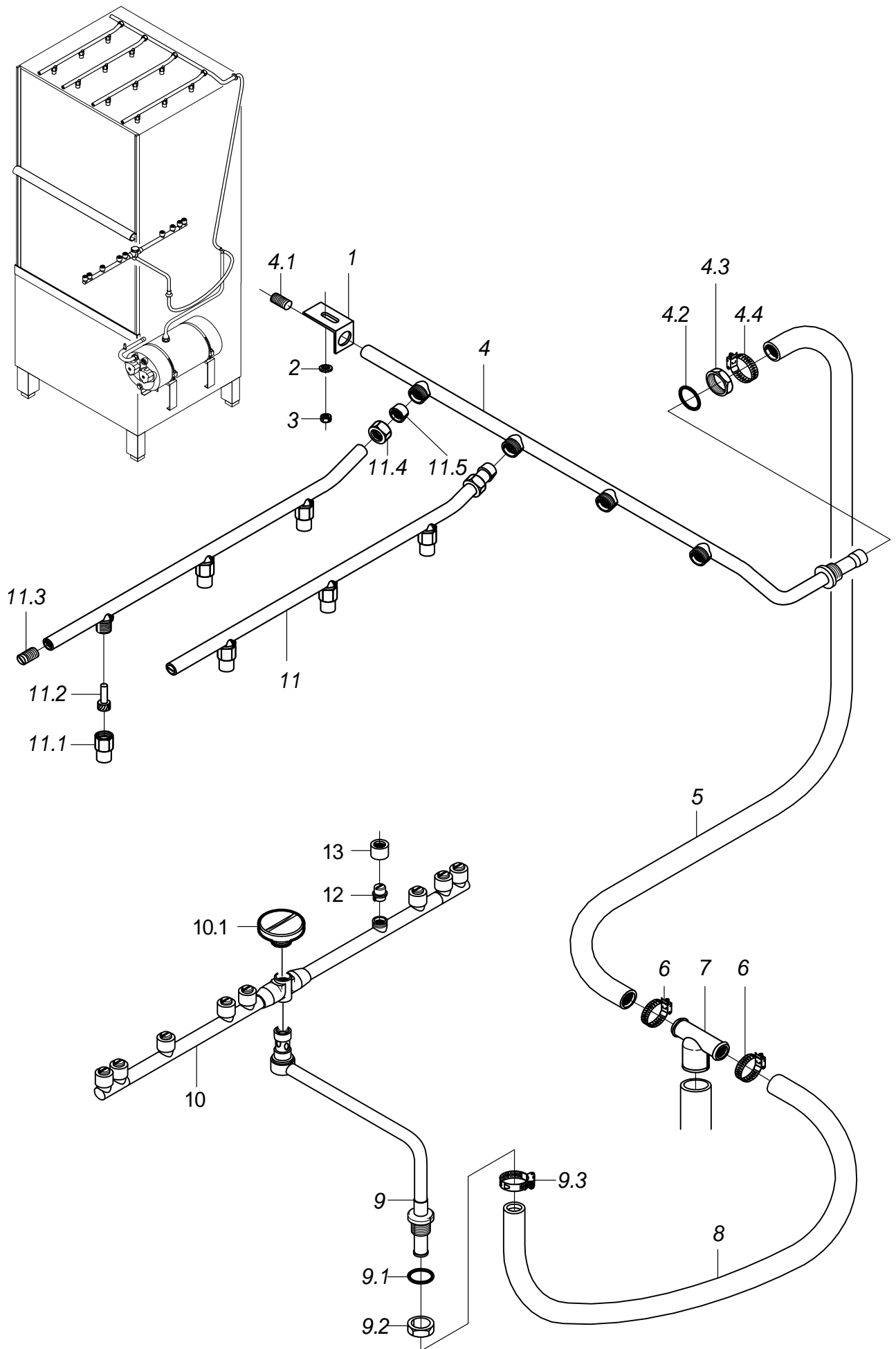

GS 640-650 65005038-01

GS 640 / GS 650

Rinse system GS 640: ...814 318; GS 650: ...813 826

Item.	Designation	Parts no.	Pc.	Notes
1	Elbow; 1,0 X 20 X 58	65003117		
2	Washer; D5,3 X D12 X 0,8	22 02 313		
3	Hexagonal nut self securing; M5	21 05 302		
4	Rinsing manifold top	65000032		incl. item 4.1 - 4.4
4.1	Threaded pin; M11 X 1,0 X 20	20 30 503		
4.2	O-ring; 16 X 2,5	27 07 001		
4.3	Hexagonal nut; G 3/8" X 5,5; SW22	30 09 200		
4.4	Hose clamp; D12-22 X 9	30000711		
5	Hose elbow 90°; DN12,5 X 4,0; 30 X 1080	61005784		
6	Hose clamp; D12-22 X 9	30000711		
7	T-piece; D25 X D14,5 X 14,5	62001329		
8	Industrial hose; DN13 X 3,5	40 02 035		810 mm; "By-the-metre" goods
9	Revolving arm holder cpl.	65004811		incl. item 9.1 – 9.3
9.1	O-ring; 20 X 3,5	27 07 040		
9.2	Hexagonal nut; G 1/2" X 8,0; SW27	30 09 201		
9.3	Hose clamp; D12-22 X 9	30000711		
10	Revolving rinse arm kit; 9 DÜSEN	65005499		incl. item 10.1
10.1	Screw cap; M10 X D7,8 X D24	61005681		
11	Rinse pipe cpl.	65004011	2	1st jet 30mm from the front
11	Rinse pipe cpl.	65004012	2	1st jet 120mm from the front
11.1	Spray jet cap; D14,6 X 21	65002765	3	
11.2	Spray jet swirl; D8 X 18,8	65002764	3	
11.3	Threaded pin; M9 X 40	20 30 502		
11.4	Coupling nut; G 3/8" X D10,2; SW22	29 07 200		
11.5	Clamping ring; D10,2	29 07 500		
12	Fan jet, size 5; D11,2 X 10	62002820	9	
13	Coupling nut; M14 X D9,1; D17	62002812	9	

GS 640 / GS 650

Rinse system GS 640: 814 319...; GS 650: 813 827...

Item.	Designation	Parts no.	Pc.	Notes
1	Revolving rinse arm kit; 9 DÜSEN	65005462	2	incl. item 1.1
1.1	Rotary arm screw; M12 X 36; SW19	60004123		
2	Top rinsing manifold cpl.	65005465		incl. item 2.1 – 2.3
2.1	O-ring; 16 X 2,5	27 07 001		
2.2	Hexagonal nut; G 3/8" X 5,5; SW22	30 09 200		
2.3	Hose clamp; D12-22 X 9	30000711		
4	Hexagonal nut self securing; M5	21 05 302		
5	Hose elbow 90°; DN12,5 X 4,0;30 X 1080	61005784	2	
6	Hose clamp; D12-22 X 9	30000711	2	
7	T-piece; D25 X D14,5 X 14,5	62001329		
8	Rotating arm holder compl.	65005461		from machine no.: 828 455
8.1	O-ring; 20 X 3,5	27 07 040		
8.2	Hexagonal nut; G 1/2" X 8,0; SW27	30 09 201		
8.3	Hose clamp; D12-22 X 9	30000711		
9	Rinse arm holder anti-rotation element set	65005560		up to machine no.: 828 454

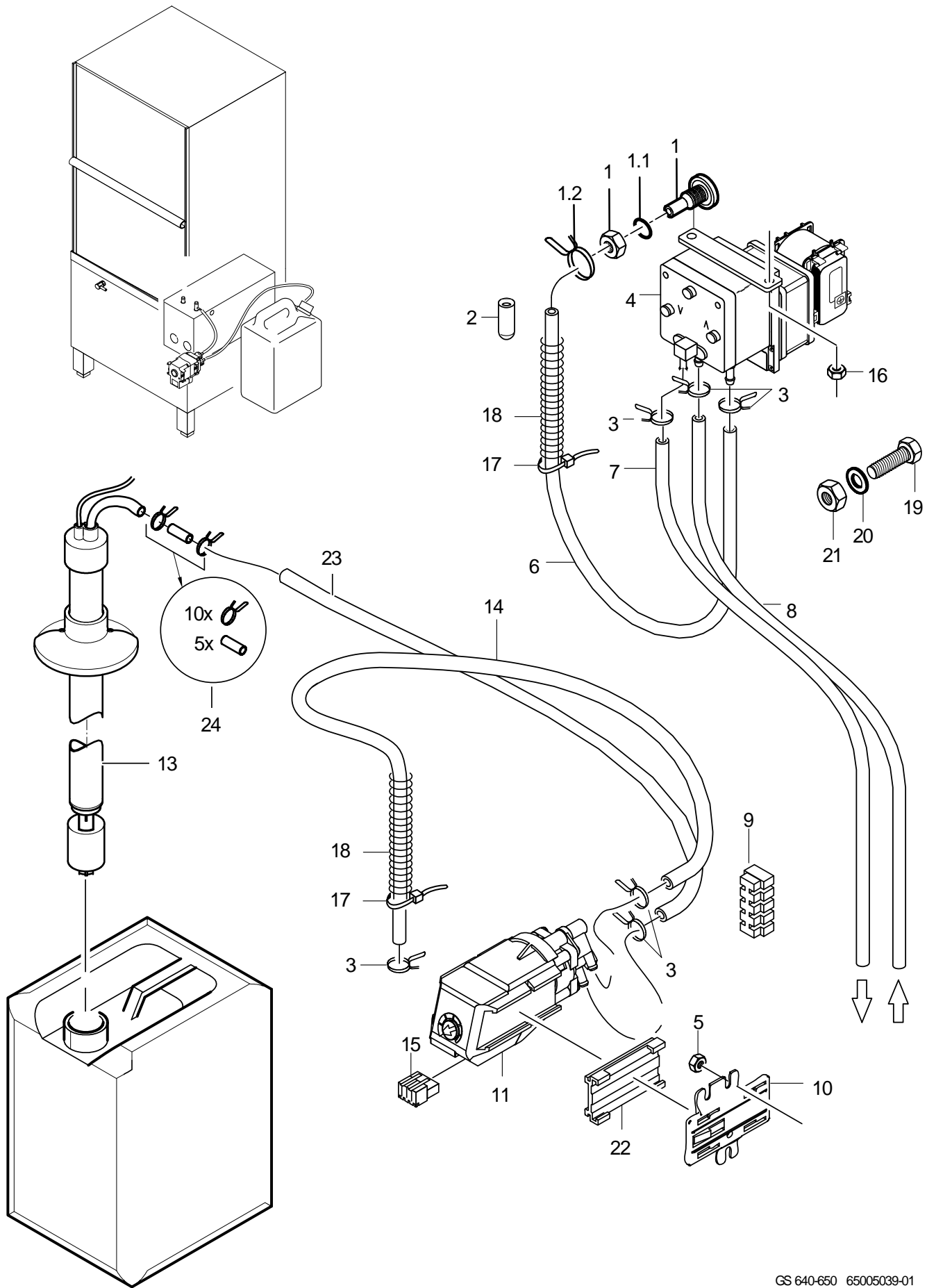

GS 640-650 65005039-01

GS 640 / GS 650

Dosage

Item.	Designation	Parts no.	Pc.	Notes
1	Dosing nipple set; M10 X 29; SW5	61005883		incl. item 1.1 - 1.2
1.1	O-ring; 10 X 2,5	30000723		
1.2	Wire hose clamp; D8,6 X 1	28 02 348		
2	End cap; D5,7 X 25,4	35 06 180		
3	Wire hose clamp; D8,6 X 1	28 02 348		
4	Detergent pump ESP166; 230V/50HZ / 65 X 88 X 100	30000027		contains all parts for retrofit of detergent dosage unit
4	Detergent dosing pump ESP166; 180-260V/60HZ / 65 X 88	80002900		contains all parts for retrofit of detergent dosage unit
5	Hexagonal nut self securing; M4	21 05 300		
6	Hose; DN5 X 1,5	40 01 024		500 mm; "By-the-metre" goods
7	Hose; DN5 X 1,5	40 01 024		1000 mm; "By-the-metre" goods
8	Hose; DN5 X 1,5	40 01 024		3500 mm; "By-the-metre" goods
9	Binding post; 5-POLIG; 6QMM; 56,5LG	31 09 230		
10	Bracket; 75 X 82,5	80002906		
11	ELT 10 replacement set	55 28 278		up to WPS-version 002
11	Rinse aid pump Fluidos DB; 115-240V/50-60HZ	31 02 598		WPS-version 003 onward
13	KIT SUCTION PIPE SD 425 FOR RINSE AID	30000011		
14	Hose; DN5 X 1,5	40 01 024		700 mm; "By-the-metre" goods
15	Macro-module plug 5, 4-pole; 250V/4KV/3; 2,5MM2	31 12 094		
16	Self-locking nut with serrated surface; M4	21 01 313	2	
17	Nylon clip; 100 X 2,5	31 20 014	2	
18	Spring; D0,8 X DI10 X 280	62002419		
19	Hexagon screw; M10 X 16; A70	20 01 352		
20	Gasket; D10 X D18 X 1,5	27 03 003		
21	Hexagonal nut; M10	21 05 308		
22	Adapter; 11,4 X 33,5 X 57,5	80003775		
23	Hose blue; DN5 X 1,5	40 01 027		1000 mm; "By-the-metre" goods
24	Kit connecting piece for chemical hose (5 pcs.)	30000012		
o.P.	Anti-foaming dosing set	55 28 277		up to WPS-version 002
o.P.	Anti-foaming dosing set	55 28 280		WPS-version 003 onward

GS 54J: ... 814318

GS 650: ... 813826

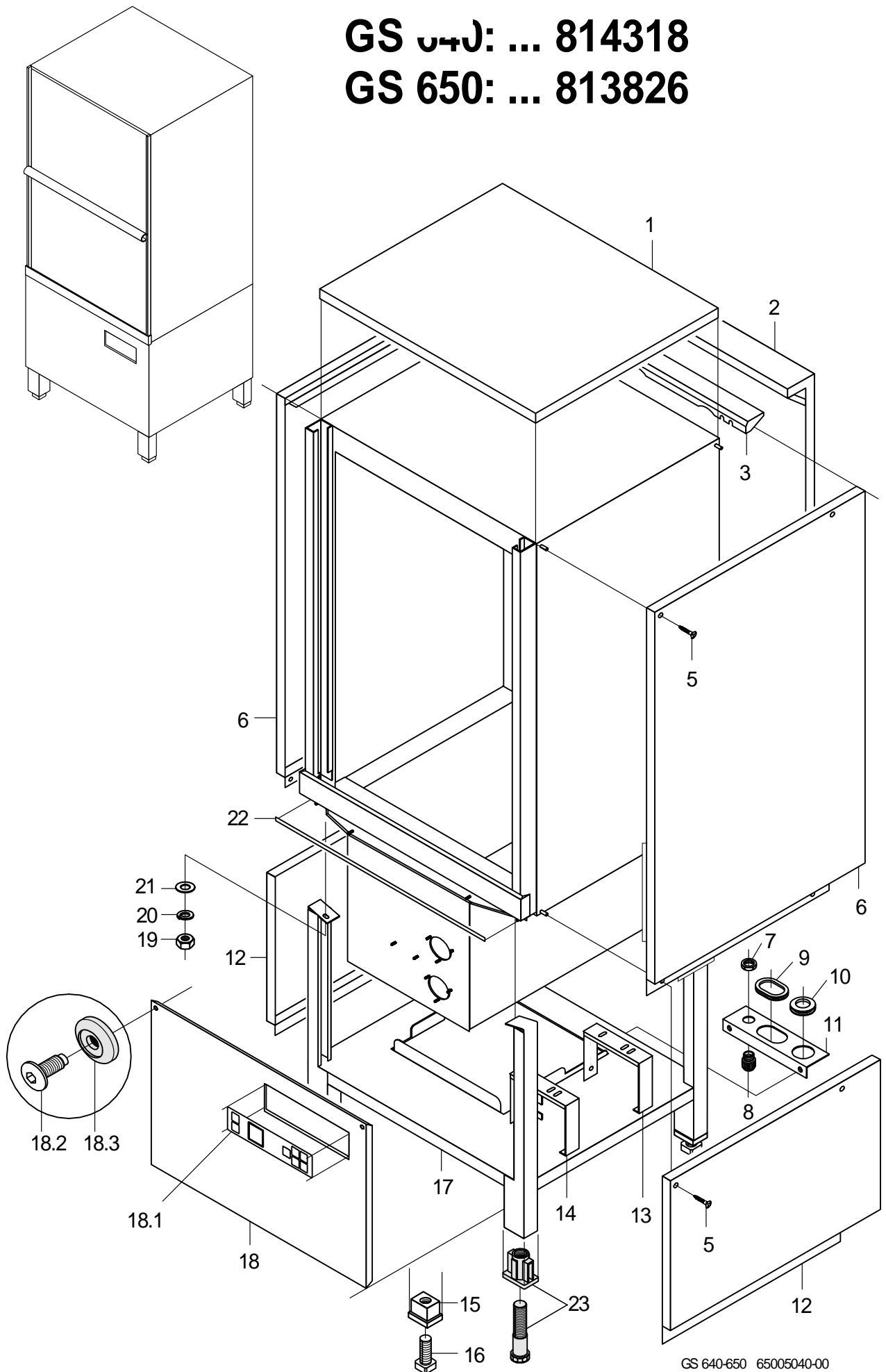

GS 640-650 65005040-00

GS 640 / GS 650

Chassis, container and panelling GS 640: ...814 318; GS 650: ...813 826

Item.	Designation	Parts no.	Pc.	Notes
1	Top trim panel; 1,0 X 761,5 X 771	65004646		
2	Rear wall panelling cpl.	65004661		GS 640
2	Rear wall panelling cpl.	65004656		GS 650
3	Elbow; 1,5 X 69,65 X 684,5	65004744		
5	Truss-head screw with retaining ring; M5 X 15	70005097	8	
6	Top panelling; 1,0 X 890 X 936	65004650	2	GS 640
6	Top panelling; 1,0 X 890 X 1106	65004610	2	GS 650
7	Hex nut; PG29	31 10 047		
7	Reducing ring; PG29/PG21	31 10 091		
8	Cable gland; PG21; 10-18 MM; IP68	31 10 070		
8	Cable gland; PG29; 16-25 MM; IP68	31 10 123		
9	Membrane spout; 6,0 X 58 X 76; D17	61004891		
10	Membrane spout; 6,0 X D57 X D73; D40	61004889		
11	Elbow; 1,0 X 111 X 307	65004988		
12	Bottom panelling cpl.	65004547	2	
13	Bracket; 1,5 X 67 X 559	65004070		
14	Bracket cpl.	65004618		
15	Threaded insert; G 3/4"; 42 X 62 X 50	35 01 063	4	up to machine no.: 443 253
16	Adjustable foot; G 3/4"; 32 X 32 X 100	35 01 064	4	up to machine no.: 443 253
17	Base frame	65005024		
18	Housing panel front	65005059		up to machine no.: 804 363
18	Housing panel front	65005259		from machine no.: 804 364
18.1	Pad -Operating Panel-; 0,175 X 50 X 180	31 24 223		
18.2	Truss-head screw with retaining ring; M5 X 15	70005097	2	
18.3	Washer; D7,2 X D26 X 5,14	70003135	2	blue
19	Hexagonal nut; M8	21 01 305		
20	Spring washer; B8	23 03 301		
21	Washer; D8,4 X D17 X 1,6	22 01 303		
22	Sealing profile; 1,0 - 2,0MM	40 04 006		716 mm; "By-the-metre" goods
23	Adjustable foot with threaded insert	61008117	4	from machine no.: 443 254
o.P.	Silicone adhesive Elastosil E43; 90 ML	34 03 012		for profile seal

GS 640: 814319 ...
GS 650: 813827 ...

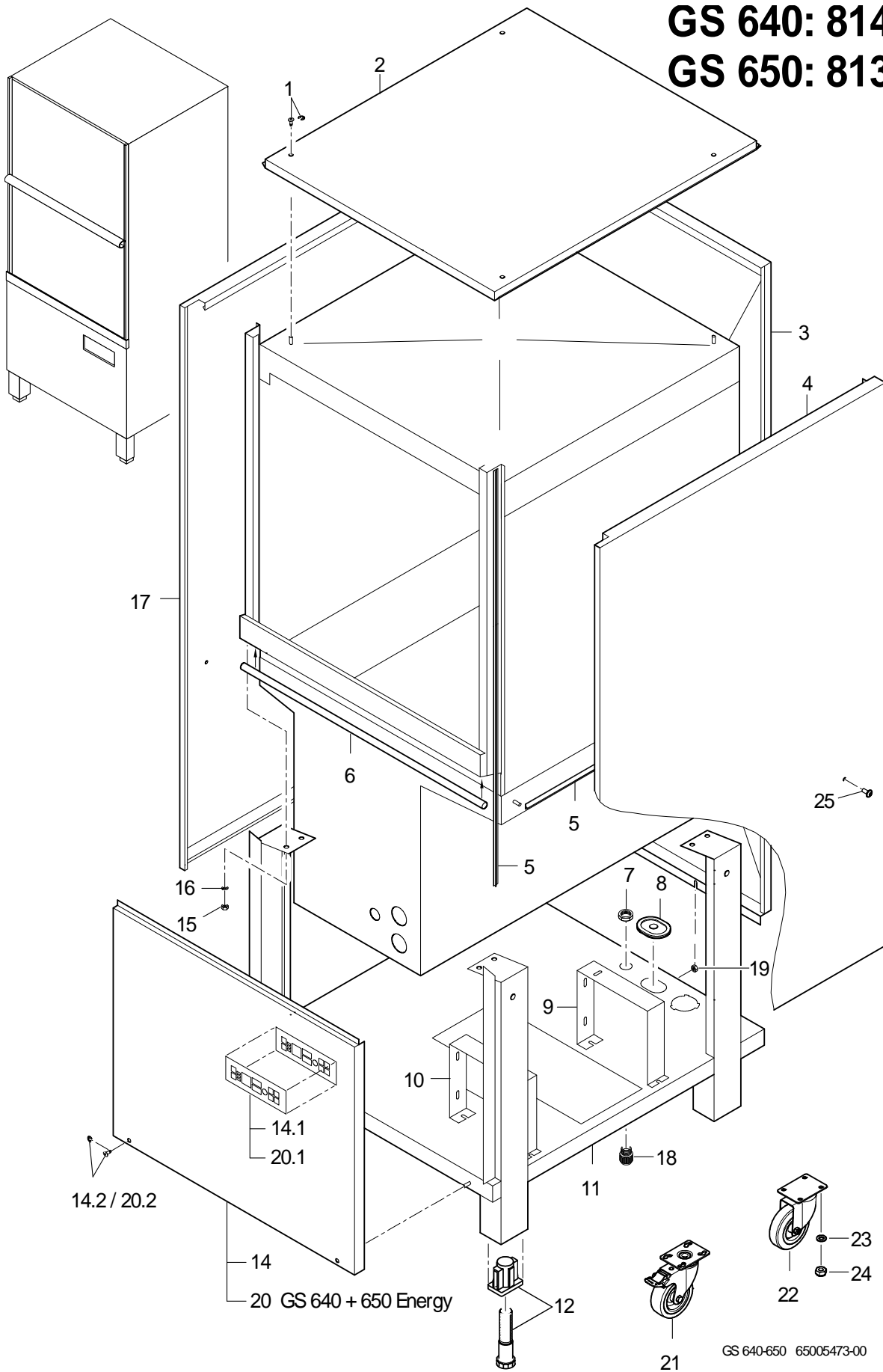

GS 640 / GS 650

Chassis, container and panelling GS 640: 814 319...; GS 650: 813 827...

Item.	Designation	Parts no.	Pc.	Notes
1	Nut + Locking ring	65005475	4	
2	Top trim panel; 1,0 X 752,2 X 844,1	65005399		
2	Housing	80003630		GS 640 + GS 650 Energy
3	Back panel	65005536		GS 640
3	Back panel	65005537		GS 650
4	Panel right	65005417		GS 640; up to mach. no. 1151261
4	Panel right GS 640; 0,8 X 934,6 X 1576,9	65006437		GS 640; from mach. no. 1151262
4	Panel right	65005334		GS 650; up to mach. no. 1152561
4	Panel right GS 650/660; 0,8 X 934,6 X 1746,9	65006433		GS 650; from mach. no. 1152562
5	Sealing profile; 6,0 X 12 X 1100	65005446	2	
6	Profile sealing; D15	40 04 020		720mm; "By-the-metre" goods
7	Hex nut; PG29	31 10 047		
8	Membrane spout; 6,0 X 58 X 76; D17	61004891		
9	Boiler support; 1,5 X 50 X 619	65005132		
10	Boiler support; 1,5 X 128,5 X 629	65005130		
11	Base frame	65005364		
12	Adjustable foot with threaded insert	61008117	4	
14	Housing panel front	65005464		
14.1	Pad -Operating Panel-; 0,175 X 50 X 180	31 24 223		
14.2	Nut + Locking ring	65005475	2	
15	Hexagonal nut; M8	21 01 305	8	
16	Spring washer; B8	23 03 301	8	
17	Panel left; 1,0 X 933 X 1577,5	65005416		GS 640; up to mach. no. 1151261
17	Panel left GS 640; 0,8 X 934,6 X 1576,9	65006435		GS 640; from mach. no. 1151262
17	Panel left; 1,0 X 933,0 X 1747,5	65005158		GS 650; up to mach. no. 1152561
17	Panel left GS 650/660; 0,8 X 934,6 X 1746,9	65006431		GS 650; from mach. no. 1152562
18	Cable gland; PG21; 10-18 MM; IP68	31 10 070		
18	Cable gland; PG29; 16-25 MM; IP68	31 10 123		
19	Ratchet nut; M5	21 01 310	2	
20	Housing panel front	65005589		GS 640 + GS 650 Energy
20.1	Pad Operating Panel Energy; 0,175 X 50 X 180	31 24 281		
20.2	Nut + Locking ring	65005475		
21	Swivel castor with brake; D100	28 01 057	2	
22	Swivel castor without brake; D100	28 01 056	2	
23	Washer; D6,4 X D12,5 X 1,6	22 01 302	16	
24	Hexagonal nut; M6	21 05 304	16	
25	Nut + Locking ring	65005475	4	GS 640; up to mach. no. 1151261
25	Raised head screw with flange; M5 X 12 MIT FLANSCH	20 10 006	4	GS 640; from mach. no. 1151262
25	Nut + Locking ring	65005475	4	GS 650; up to mach. no. 1152561
25	Raised head screw with flange; M5 X 12 MIT FLANSCH	20 10 006	4	GS 650; from mach. no. 1152562

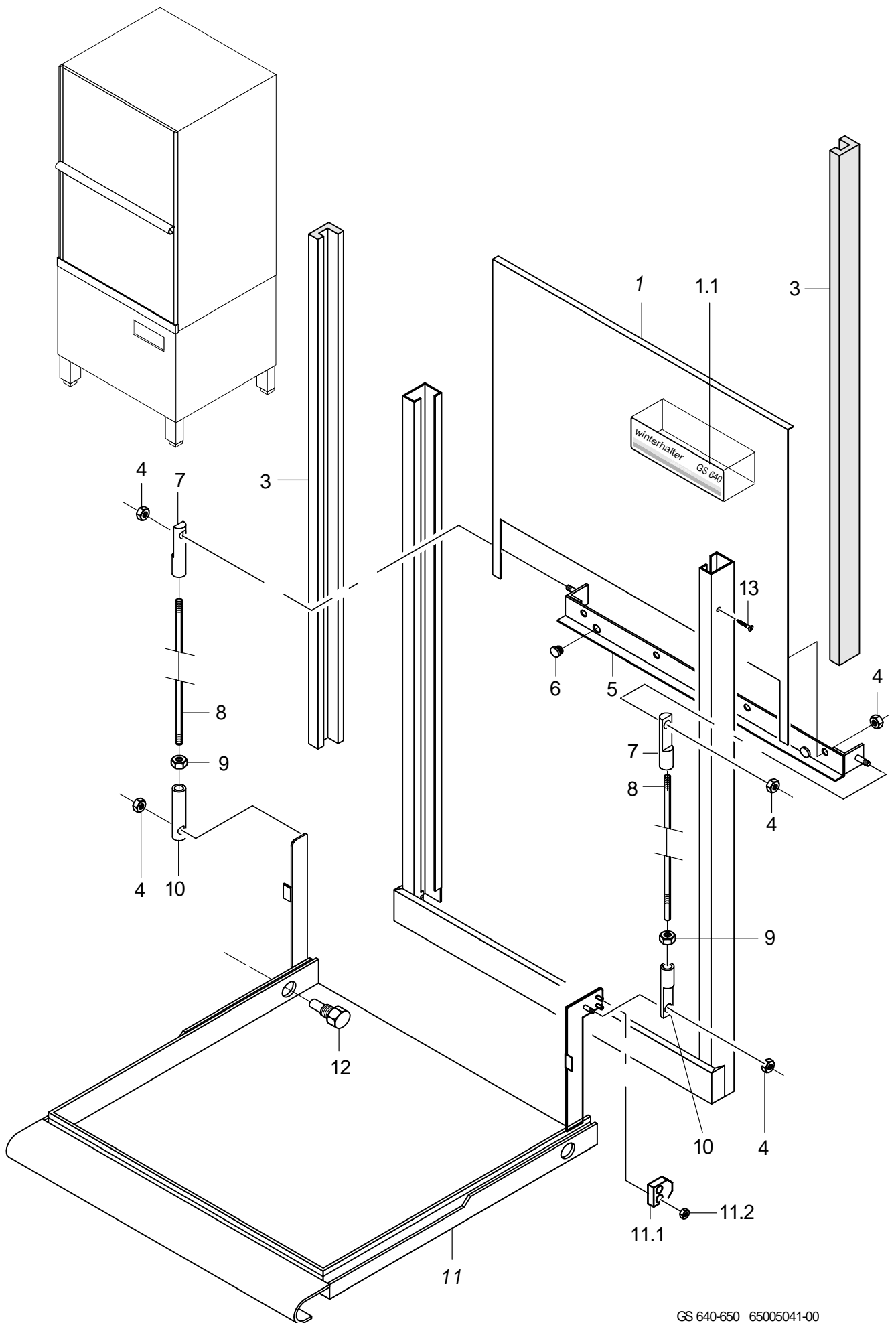

GS 640-650 65005041-00

GS 640 / GS 650

Door

Item.	Designation	Parts no.	Pc.	Notes
1	Lifting door	65005552		GS 640
1.1	Plate -Winterhalter GS 640-; 0,175 X 35 X 126	65005572		
1	Lifting door	65005553		GS 650
1.1	Plate -Winterhalter GS 650-; 0,175 X 35 X 126	65005573		
3	Guide profile; 33,75 X 39 X 745	65004668	2	GS 640
3	Guide profile; 33,75 X 39 X 915	65004448	2	GS 650
4	Hexagonal nut; M6	21 05 304		
5	Mounting rail cpl.	65003970		
6	Snap fastener buffer; D13 X 8,5 HOCH	40 06 015	2	
7	Adjusting knob; M8 LH; D12 X 53	65001617	2	Left-hand thread
8	Door connecting rod; D8 X 375	65004216	2	GS 640
8	Door connecting rod; D8 X 504	65004184	2	GS 650
9	Hexagonal nut; M8	21 01 305		
10	Adjusting knob; M8 RH; D12 X 53	65001616	2	
11	Flap door cpl.	65004037		GS 640
11	Flap door cpl.	65003963		GS 650
11.1	Set magnet support	55 28 291		incl. magnet
11.2	Hexagonal nut self securing; M5	21 05 302	2	
12	Bearing bolt; SW15 X 26	65001537	2	
13	Sheet metal screw; ST 2,9 X 13	20 20 302		

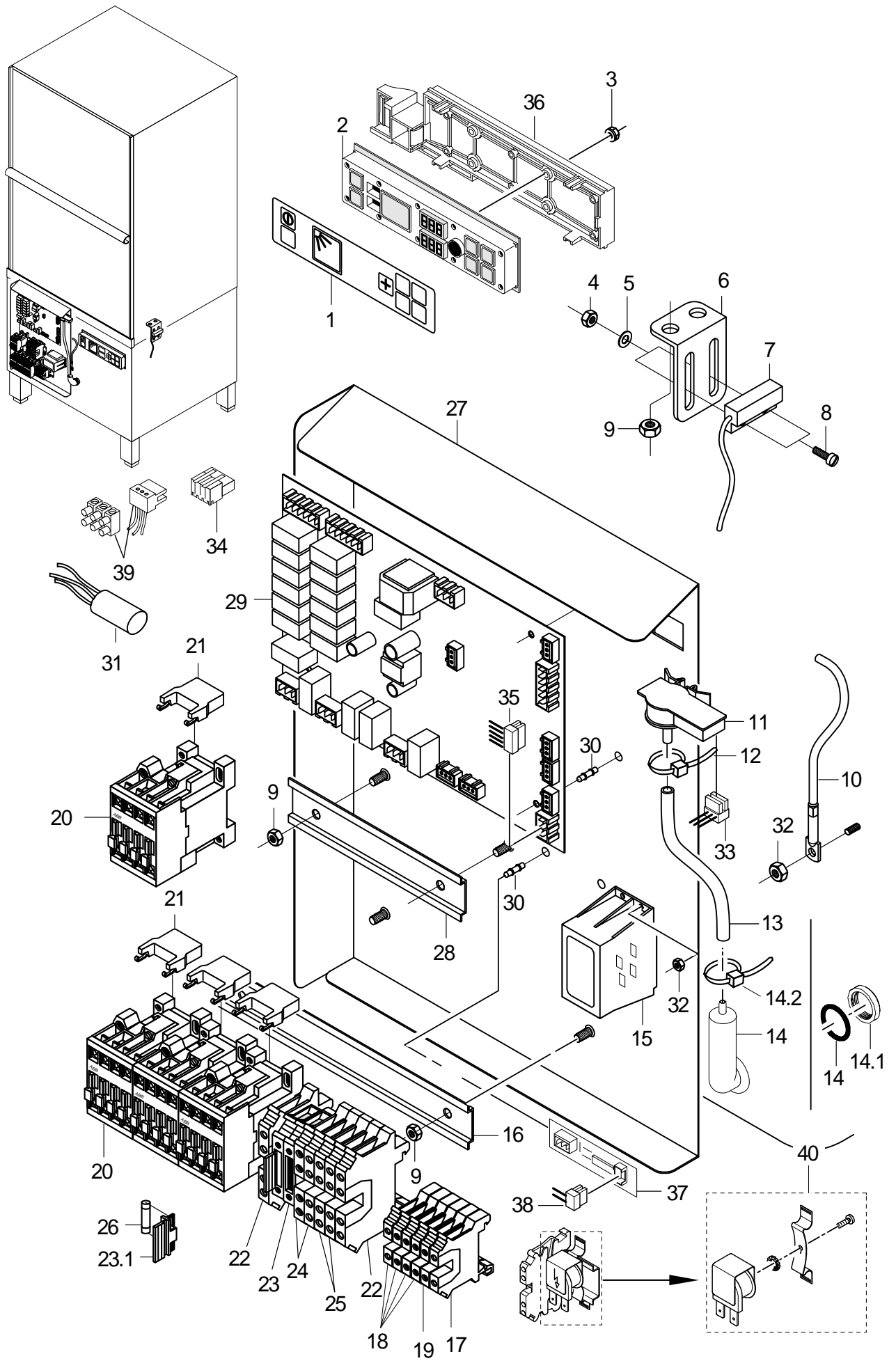

GS 640-650 65005042-00

GS 640 / GS 650

Electric parts

Item.	Designation	Parts no.	Pc.	Notes
1	Pad -Operating Panel-; 0,175 X 50 X 180	31 24 223		
2	Operating panel; 25 X 55 X 210	31 24 222		
3	Nut with soft push; M3, SW7, MAX. 160 NM	31 13 116	10	up to machine no.: 804 363
3	Nut-and-washer assembly; M3	21 01 312	4	from machine no.: 804 364
4	Hexagonal nut self securing; M4	21 05 300		
5	Washer; D4,3 X D12 X 1,0	22 05 300		
6	Elbow; 0,8 X 32 X 41,3	62003393		
7	Magnetic switch; 32 X 14,9 X 6,9;1000LG	31 24 224		
8	Cylinder head screw; M4 X 12	20 09 312		
9	Hexagonal nut self securing; M5	21 05 302		
10	Thermal sensor kit 1000mm	80003803		with heat-conducting foil
11	Pressure transmitter; 0-30MBAR;5VDC/0,5-3,5V	31 26 044		
12	Cable tie; 100 X 2,5	31 20 175		
13	Hose; DN5 X 1,5	40 01 024		210 mm; "By-the-metre" goods
14	Air chamber set	60003525		incl. item 14.1 – 14.2
14.1	Nut; D26,2 X 8,5; SW32	60004612		
14.2	Cable tie; 100 X 2,5	31 20 175		
15	Transformer; 230V/1/50HZ	31 15 020		
16	Snap-on rail; 7,5 X 35 X 230	65004603		
17	Double terminal, UK, 10-Twin-PE	31 09 224		
18	Twin terminal, grey	31 09 222	4	
19	Twin terminal, blue	31 09 223		
20	Contacteur AF16; 100-250V/50-60HZ AC/DC; 7,5KW	30000861	4	
21	RC element; 250V	31 13 166	4	
22	UDK 4-PE double terminal	31 09 153		
23	Universal fuse clip	31 09 063	2	incl. item 23.1
23.1	Securing plug	31 09 072		
24	UDK 4 double terminal	31 09 151	2	
25	UDK 4 BU double terminal	31 09 152	2	
26	Fine fuse, medium time lag; 250V; 4,0A; 5 X 20	31 11 123	2	retrofitable
27	Assembly plate	65004919		
28	Snap-on rail; 7,5 X 35 X 160	65004929		
29	Programme control WPS MAX Kit; 180-265V; 50/60HZ	31 05 139		
30	Spacer; 18,70MM LANG	31 13 115	6	
o.P.	WPS dismantling tool	31 20 170		
31	Radio interference suppression capacitor; 0,27MF + 2 X 27000PF	31 13 078		
32	Ratchet nut; M5	21 01 310	2	
33	Universal cable pressure transmitter; 3 X 0,34QMM; 1520 LG	82000120		
34	Macro-module plug 5, 2-pole; 250V/4KV/3; 2,5MM2	31 12 091		
34	Macro-module plug 5, 3-pole; 250V/4KV/3; 2,5MM2	31 12 093		
34	Macro-module plug 5, 4-pole; 250V/4KV/3; 2,5MM2	31 12 094		

For missing items, see next page

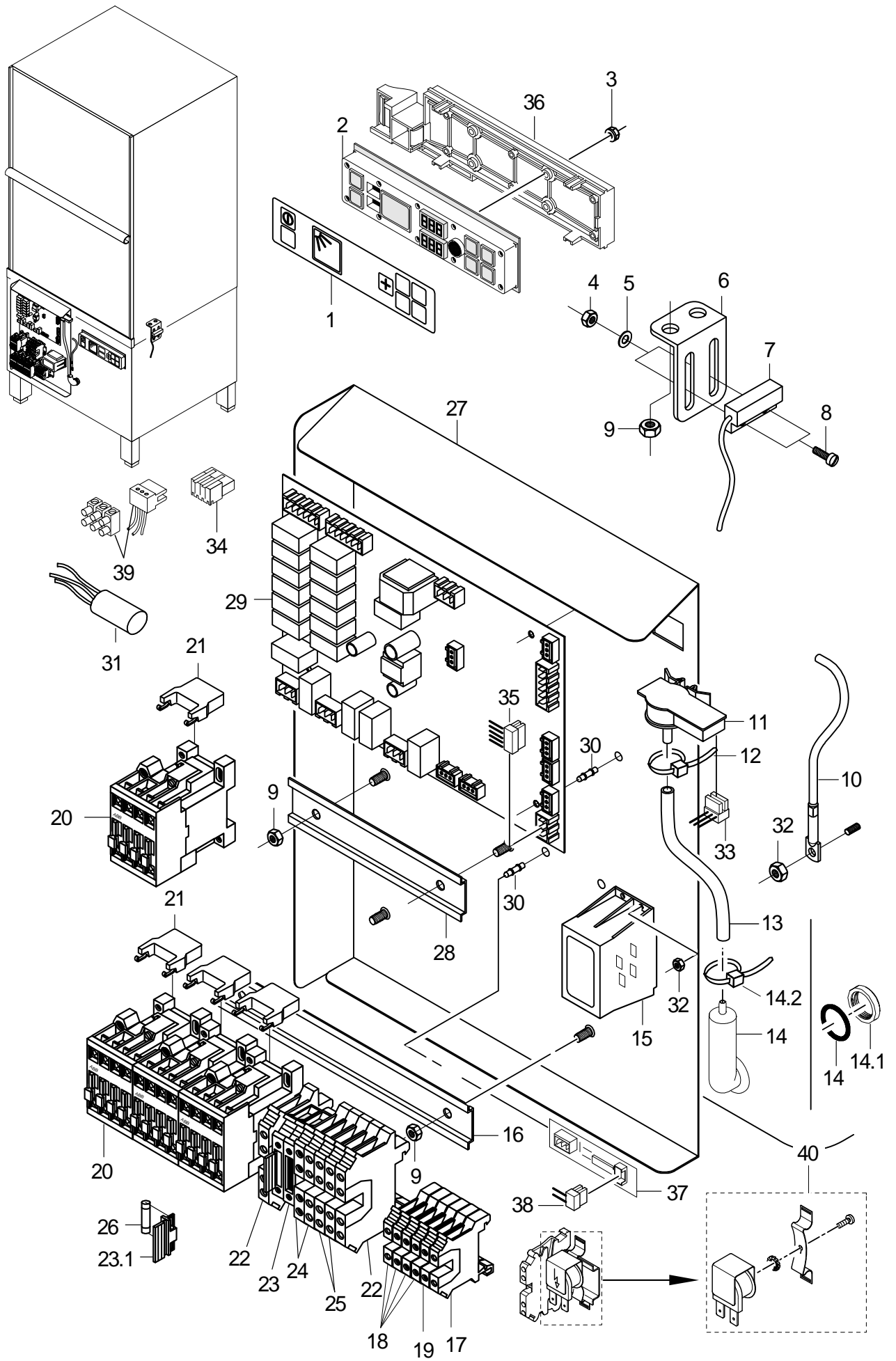

GS 640-650 65005042-00

GS 640 / GS 650

Electric parts

Item.	Designation	Parts no.	Pc.	Notes
35	Bus cable set	65005466		
36	Support for operating panel	60003350		from machine no.: 804 364
37	Level sensor, electronic; 12V; 7MA; 80 X 20 MM	31 13 164		GS 640: from mach. no. 814 319
37	Level sensor, electronic; 12V; 7MA; 80 X 20 MM	31 13 164		GS 650: from mach. no. 813 827
38	Cable for level sensor; 2 X 0,34QMM	60003175		GS 640: from mach. no. 814 319
38	Cable for level sensor; 2 X 0,34QMM	60003175		GS 650: from mach. no. 813 827
39	Macro-module plug repair kit (3-pole; RAST 2,5)	30000198		
40	Set of acoustical level indicators; WPS MAX. VORHANDEN	55 28 283		
o.P.	Control unit wire set; 0,75QMM	65005016		

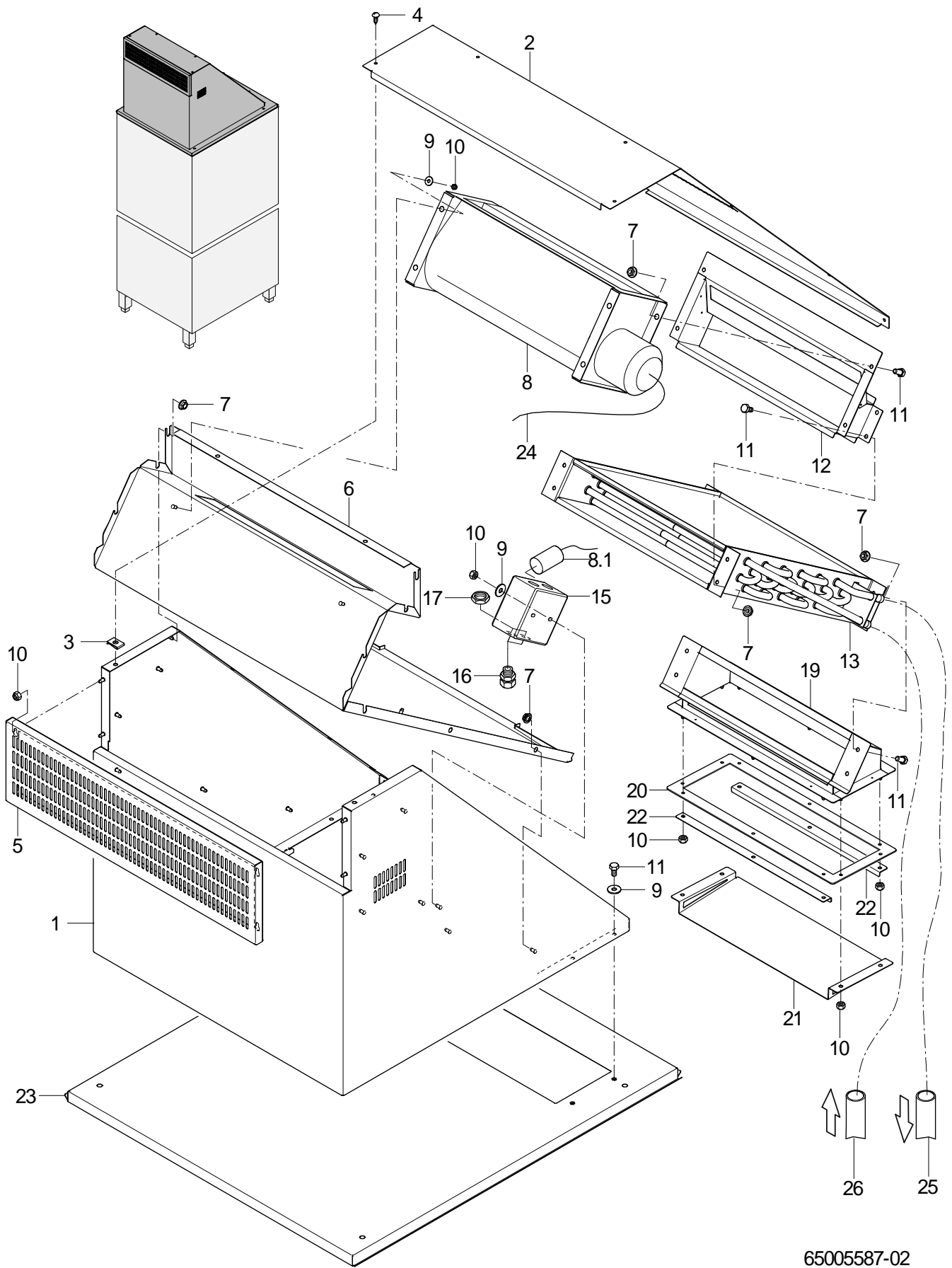

65005587-02

GS 640 / GS 650

Vapour extraction GS 640 + GS 650 Energy

Item.	Designation	Parts no.	Pc.	Notes
1	Housing	80003691		
2	Cover; 1,0 X 594,5 X 962,1	80003698		
3	Sheet metal nut; B 3,9	21 17 301	10	
4	Sheet metal screw; ST 3,9 X 11	30011208	10	
5	Orifice; 1,25 X 225,9 X 659,9	80003635		
6	Vapour deflector plate	80003709		
7	Ratchet nut; M5	21 01 310	12	
8	Cross flow fan; 200-240V/50-60HZ	30000741		
8.1	Capacitor; 1,5 MICRO F / 400V	31 13 032		
9	Washer; D5,3 X D15 X 1,2	22 05 301	14	
10	Hexagonal nut self securing; M5	21 05 302	24	
11	Hexagon screw; M5 X 12; A70	30012713		
12	Connecting sleeve	80003435		
13	Heat exchanger - Copper	80003791		Copper
13	Heat exchanger - stainless steel	80003792		Stainless steel
15	10-pos. terminal block box; 57 X 94 X 94;IP54;4QMM	31 18 087		
16	Cable gland; M16 X 1,5; 5,0-10MM; SW20; IP68	31 10 151	2	
17	Hex nut; M16 X 1,5 X 5,0; SW22	31 10 161	2	
19	Connecting sleeve	80003697		
20	Seal; 2,0 X 155 X 400	80003609		
21	Cover; 1,25 X 140 X 440,6	80003611		
22	Elbow; 1,25 X 27,3 X 355	80003610		
23	Housing	80003630		
24	Cable, Energy fan; 3 G 7,5QMM, 4750 LG	65005571		
25	Industrial hose; DN13 X 3,5	40 02 035		1200 mm; "By-the-metre" goods
26	Hose elbow; DN12,5 X 4,0	40 03 051		adapt

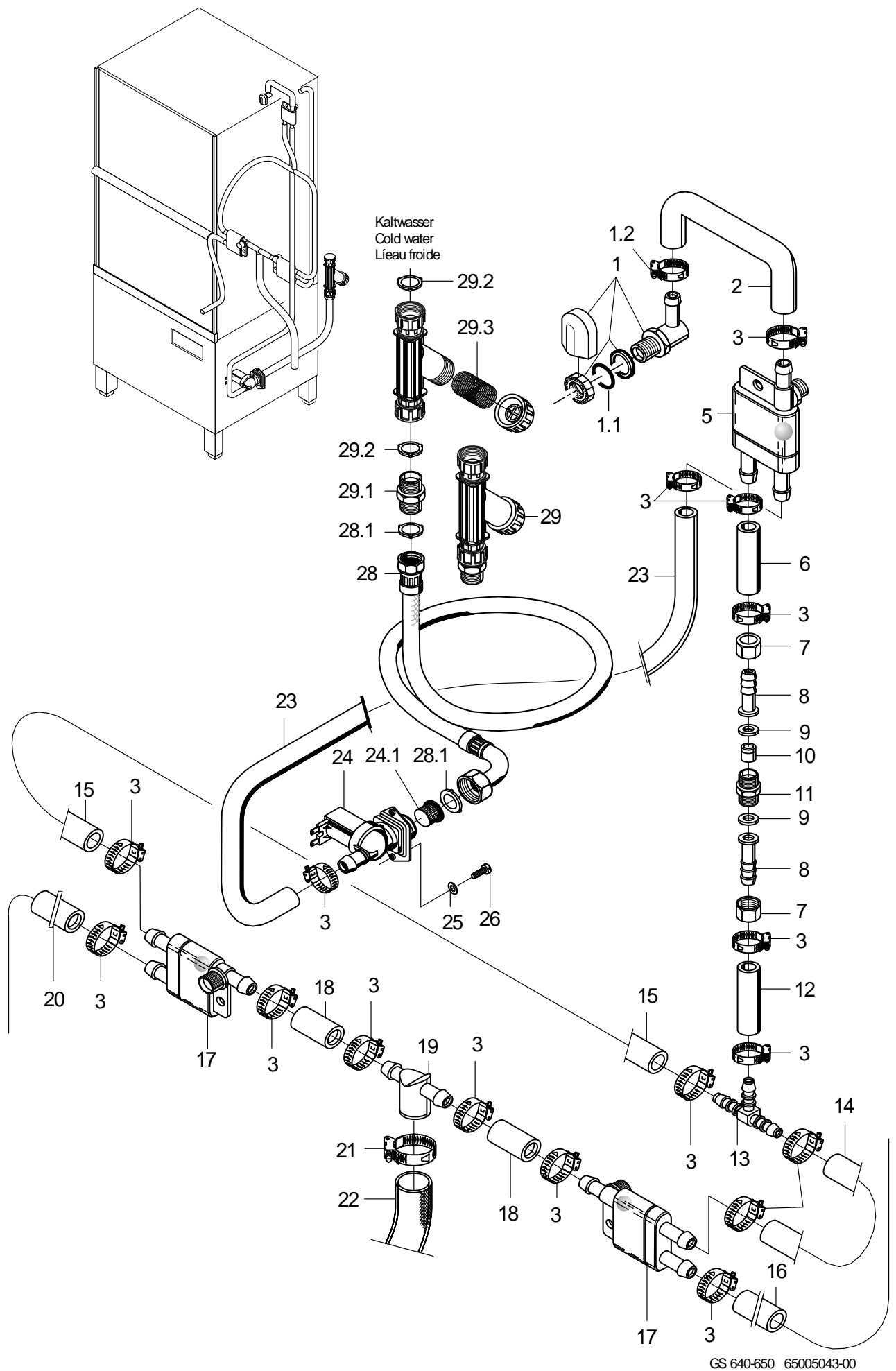

GS 640 / GS 650

Cold water pre-rinse (optional) GS 640: ...814 318; GS 650: ...813 826

Item.	Designation	Parts no.	Pc.	Notes
1	Water inlet, 3-part set	55 31 007		incl. item 1.1 - 1.2
1.1	Gasket; D21 X D28 X 2,0	27 09 011		replaced by 55 31 007
1.1	Gasket; D20,5 X D28,5 X 2,0	27 01 002		replaced by 55 31 007
1.1	O-ring; 20 X 3	27 07 031		
1.2	Hose clamp; D12-22 X 9	30000711		
2	Hose bend; DN13 X 4,0	40 03 053		
3	Hose clamp; D12-22 X 9	30000711		
5	Reverse suction preventer, top; PN6 BEI 60 GRAD C	35 01 193		
6	Industrial hose; DN13 X 3,5	40 02 035		55 mm; "By-the-metre" goods
7	Coupling nut; G 3/4" X D20,5; SW30	29 07 203		
8	Hose coupling; R 3/4" X 1/2"	60002453		
9	Gasket; D16 X D24 X 3,0	83001022		
10	Check valve; DW 20	29 01 512		
11	Double nipple; G 3/4" X 26; SW27	30 11 207		
12	Industrial hose; DN13 X 3,5	40 02 035		55 mm; "By-the-metre" goods GS 640
12	Industrial hose; DN13 X 3,5	40 02 035		225 mm; "By-the-metre" goods GS 650
13	Hose T-connecting piece; D15 X D15 X D15	70010598		
14	Industrial hose; DN13 X 3,5	40 02 035		310 mm; "By-the-metre" goods
15	Industrial hose; DN13 X 3,5	40 02 035		650 mm; "By-the-metre" goods
16	Hose elbow 90°; DN12,5 X 4,0;30 X 1080	61005784		adapt
17	Reverse suction preventer, top; PN6 BEI 60 GRAD C	35 01 193	2	
18	Industrial hose; DN13 X 3,5	40 02 035		45 mm; "By-the-metre" goods
19	T-piece; D25 X D14,5 X 14,5	62001329		
20	Industrial hose; DN13 X 3,5	40 02 035		810 mm; "By-the-metre" goods
21	Hose clamp; D24-44 X 12	28 02 309		
22	Hose bend; DN25 X 4,0	65004182		
22	Reinforced hose; DN25,4 X 4,4	40 01 023		Pressure-independent boiler
23	Industrial hose; DN13 X 3,5	40 02 035		2100 mm; "By-the-metre" goods GS 640
23	Industrial hose; DN13 X 3,5	40 02 035		2270 mm; "By-the-metre" goods GS 650
24	Solenoid valve without flow control; 220-240V/50-60HZ	31 06 187		
24	Solenoid valve without flow restrictor; 200-240V/50-60HZ/+10%	30008321		Japan
24.1	Solenoid valve filter	31 06 186		
25	Washer; D4,3 X D12 X 1,0	22 05 300		
26	Countersunk screw; M4 X 8	20 10 309		
28	WATER SUPPLY HOSE; DN13 X 3,5; 2500	40 02 060		incl. item 28.1
28.1	Gasket; D16 X D24 X 3,0	83001022	2	
29	Dirt trap; 150 MICROMETER	80002153		incl. item 29.1 - 29.3
29.1	DOUBLE NIPPLE; G 3/4" X 40; SW30	80002167		
29.2	Gasket; D16 X D24 X 3,0	83001022	2	
29.3	Strainer; D27 X 67 X 150 MICROMETER	80002728		
o.P.	Set cold pre-rinse	55 28 286		

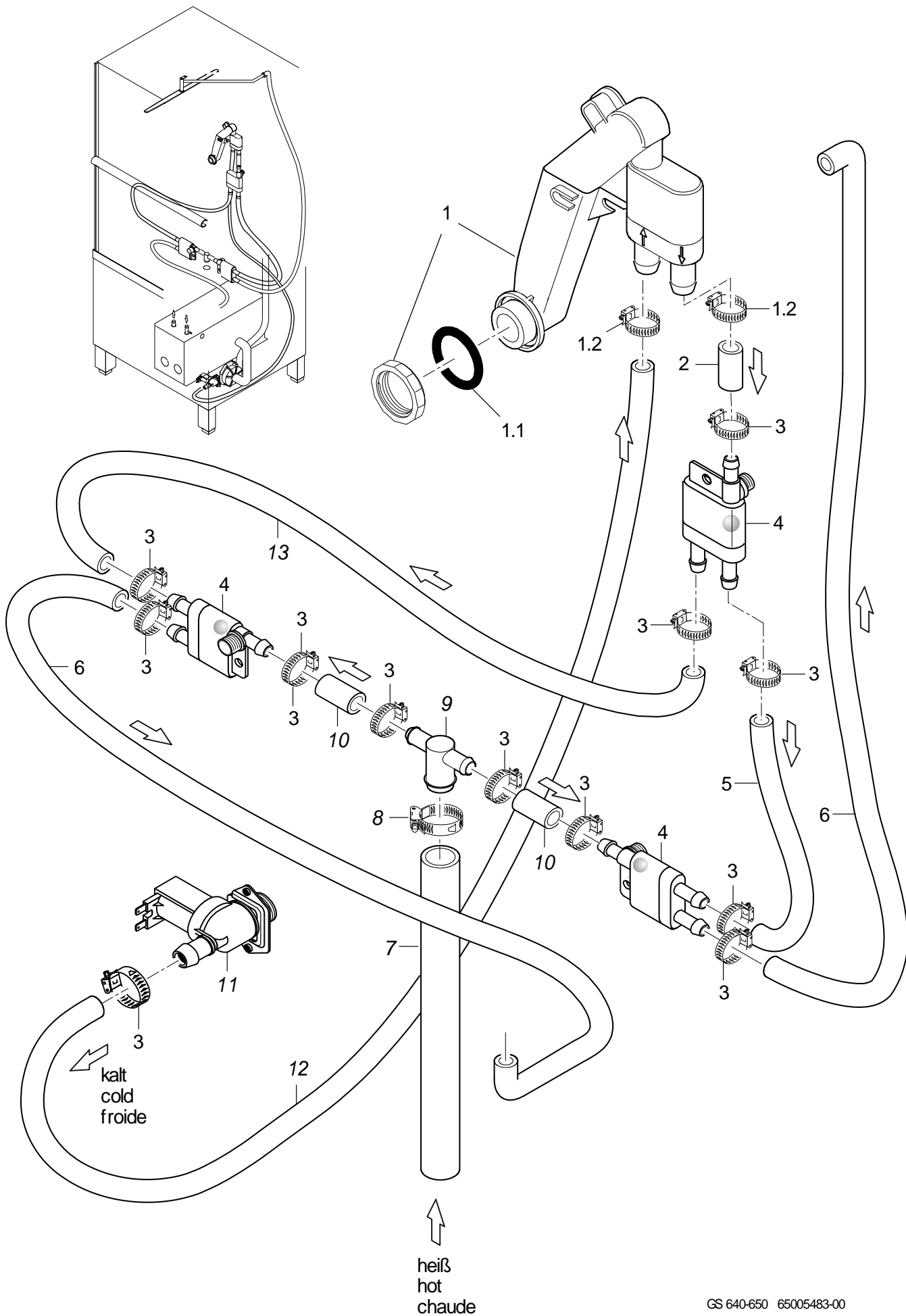

GS 640-650 65005483-00

GS 640 / GS 650

Cold water pre-rinse (optional) GS 640: 814 319...; GS 650: 813 827...

Item.	Designation	Parts no.	Pc.	Notes
1	Kit airflow preventer	60003846		incl. item 1.1 - 1.2
1.1	O-ring; 24 X 3,0	27 07 087		
1.2	Hose clamp; D12-22 X 9	30000711	2	
2	Industrial hose; DN13 X 3,5	40 02 035		150 mm; "By-the-metre" goods
3	Hose clamp; D12-22 X 9	30000711		
4	Reverse suction preventer, top; PN6 BEI 60 GRAD C	35 01 193		
5	Industrial hose; DN13 X 3,5	40 02 035		150 mm; "By-the-metre" goods
6	Hose elbow 90°; DN12,5 X 4,0;30 X 1080	61005784		
7	Hose elbow 90°; DN26X4;333,5X613,5	65005108		
8	Hose clamp; 25 - 40MM / 12MM	30002612		
9	T-piece; D25 X D14,5 X 14,5	62001329		
10	Industrial hose; DN13 X 3,5	40 02 035		50 mm; "By-the-metre" goods
11	Solenoid valve without flow control; 220-240V/50-60HZ	31 06 187		
11	Solenoid valve without flow restrictor; 200-240V/50-60HZ/+ -10%	30008321		Japan
12	Industrial hose; DN13 X 3,5	40 02 035		2040 mm; "By-the-metre" goods
13	Industrial hose; DN13 X 3,5	40 02 035		800 mm; "By-the-metre" goods
o.P.	Set cold pre-rinse	55 28 286		