

Spare parts list

GS 302 - GS 310 - GS 315

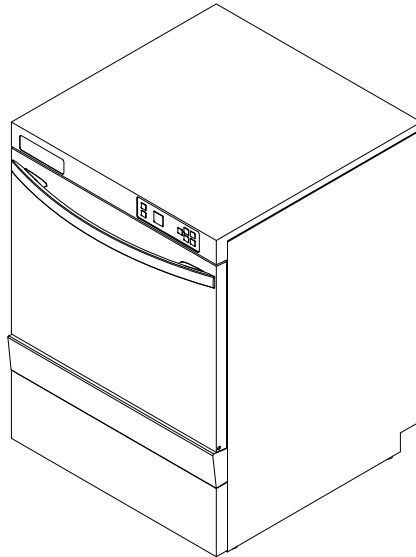

Contents

Water inlet	Page 1 - 2
Water softener GS 302, GS 315	Page 3 - 4
Water drain, Mediamat Cyclo	Page 5 - 6
Wash pump	Page 7 - 8
Bottom washing/rinsing system	Page 9 - 10
Top washing/rinsing system	Page 11 - 12
Pressure boiler GS 302, GS 315	Page 13 - 14
Pressure-independent boiler	Page 15 - 18
Dosage	Page 19 - 20
Chassis, container and panelling	Page 23 - 24
Door	Page 25 - 26
Electric parts	Page 27 - 28

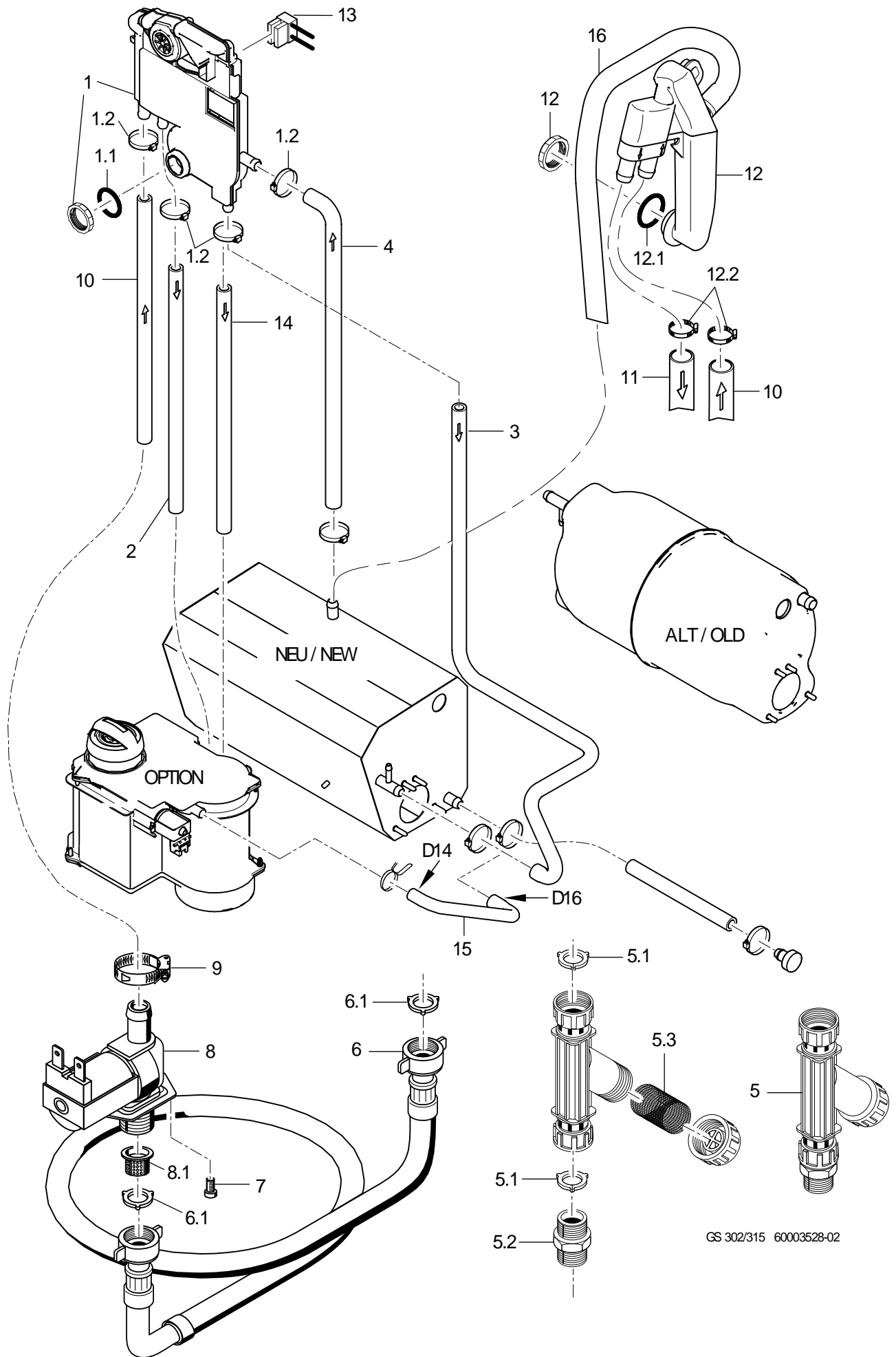

GS 302/315 60003528-02

GS 302 - GS 310 - GS 315

Water inlet

Item.	Designation	Parts no.	Pc.	Notes
1	WSE WITH IMPELLER COUNTER KIT	60003512		
1.1	O-ring; 24 X 3,0	27 07 087		
1.2	Hose clamp; D12-22 X 9	30000711	4	
2	Hose; DN10 X 2,0	40 01 050		820mm; Metre item; Regeneration water softener GS 302, GS 315
3	Moulded hose; DN10 X DN12; 549	60003154		up to machine no.: 529 866
3	Moulded hose; DN10,5 X DN12; 818	60004085		from machine no.: 529 867
4	Moulded hose; DN12,5 X 3,5; 780	60003163		up to machine no.: 529 866
4	Moulded hose; DN12 X 3,0 X 491	60004084		from machine no.: 529 867
5	Dirt trap; 150 MICROMETER	80002153		
5.1	Gasket; D16 X D24 X 3,0	83001022	3	
5.2	DOUBLE NIPPLE; G 3/4" X 40; SW30	80002167		
5.3	Strainer; D27 X 67 X 150 MICROMETER	80002728		
6	WATER SUPPLY HOSE; DN13 X 3,5; 2500	40 02 060		
6.1	Gasket; D16 X D24 X 3,0	83001022	2	
7	Countersunk screw; M4 X 8	20 10 309	2	
8	Solenoid valve flow restrictor 15l; 230-240V 50/60HZ RAST5	31 06 214		Pressure boiler ; GS 302, GS 315
8	Solenoid valve flow restrictor 5l; 230-240V 50/60HZ RAST5	31 06 215		Pressure-independent boiler
8	15 l solenoid valve set; 200-240V/50-60HZ/+10%	60004148		Pressure boiler ; GS 302, GS 315
8	Solenoid valve flow restrictor 5l; 200-208V 50/60HZ RAST5	31 06 213		Pressure-independent boiler
8.1	Solenoid valve filter	31 06 186		
9	Hose clamp; D12-22 X 9	30000711		
10	Industrial hose; DN13 X 3,5	40 02 035		670mm; "By-the-metre" goods
11	Moulded hose; DN13 X 3,5 X 716	60003155		up to machine no.: 545 164
11	Moulded hose; DN12 X DN13,5 X 3,0	60004287		from machine no.: 545 165
12	Kit airflow preventer	60003846		up to mach. no. 479 915: order too: 670 mm x 4002035 + 60003155
12	Kit airflow preventer	60003846		from machine no.: 479 916; For machines with pressure boiler
12	Kit airflow preventer	60003846		from machine no.: 545 165; For machines without integrated water softener, not for UK and Australia
12	Separate check valve set	60004391		up to machine no.: 545 164; Replacement for WSE set (pos. 1) for machines without integrated water softener, not for UK and Australia
12.1	O-ring; 24 X 3,0	27 07 087		
12.2	Hose clamp; D12-22 X 9	30000711	4	
13	Cable WMZ; 2 X 0,34QMM	60003179		Pressure-independent boiler and water softener installed
14	Hose; DN10 X 2,0	40 01 050		740 mm; "By-the-metre" goods
15	Moulded hose; DN10 X DN12,5 X 2,0	60003158		up to machine no.: 529 866
15	Moulded hose; DN10 X DN12 X 2,0	60004083		from machine no.: 529 867
16	Moulded hose; DN12 X DN13,5 X 3,0	60004288		from machine no.: 545 165

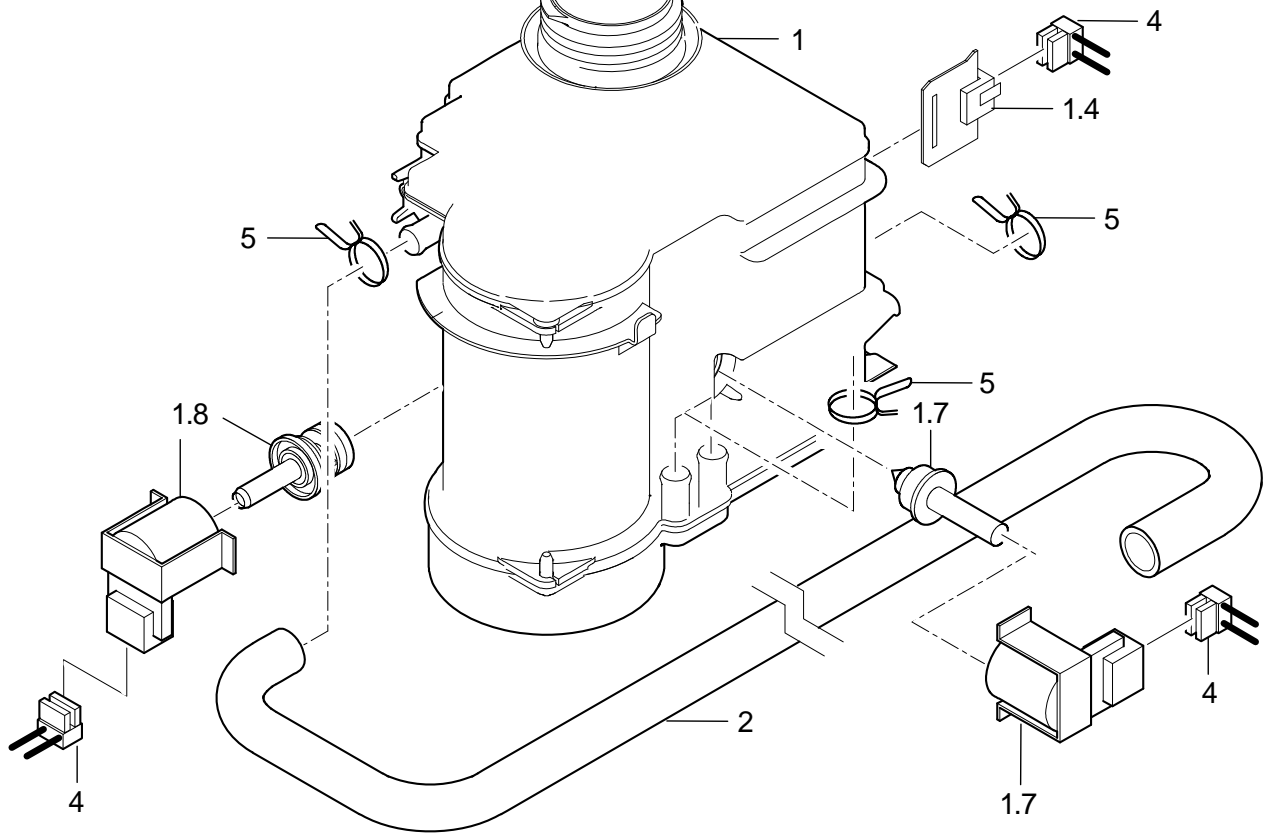
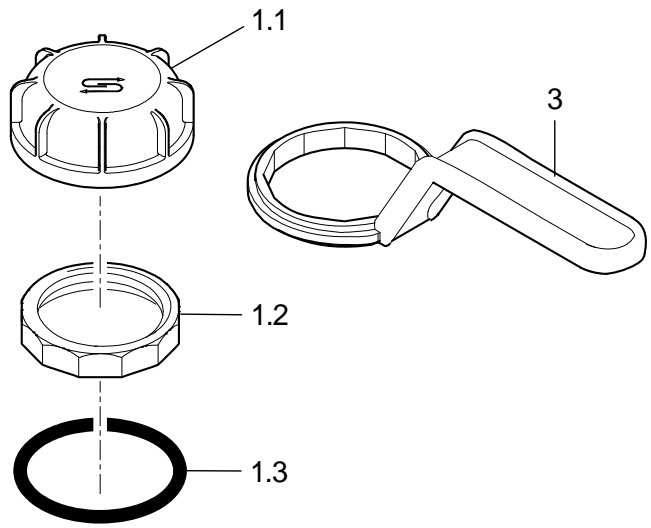
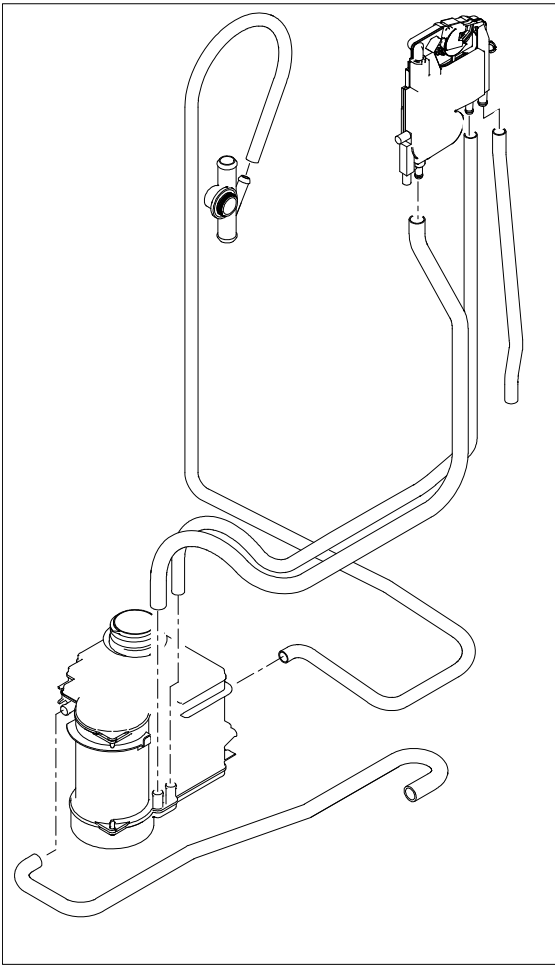

GS 302/315 60003529-00

GS 302 - GS 310 - GS 315

Water softener GS 302, GS 315

Item.	Designation	Parts no.	Pc.	Notes
1	Water softener kit; 220-240V; 50/60HZ	83000420		
1.1	Screw cap	60004894		
1.2	Lock nut; S54 X 4; D56	60003001		
1.3	O-ring; 54 X 5	27 07 065		
1.4	Dry reed contact lack of salt	83000408		
1.7	Repair kit regeneration valve; 220-240V,50/60HZ	83000402		
1.8	Repair kit reversing valve	83000460		
2	Moulded hose; DN10 X DN12,50 X 2,0	60003158		up to machine no.: 529 866
2	Moulded hose; DN10 X DN12 X 2,0	60004083		from machine no.: 529 867
3	Double hex ring spanner; SW61,5	60003376		
4	Wiring loom; Water softener	60003185		
5	Wire hose clamp; D14,4 X 15,1	28 02 344	4	
o.P.	Filling funnel; D155 X 122,6	83000501		

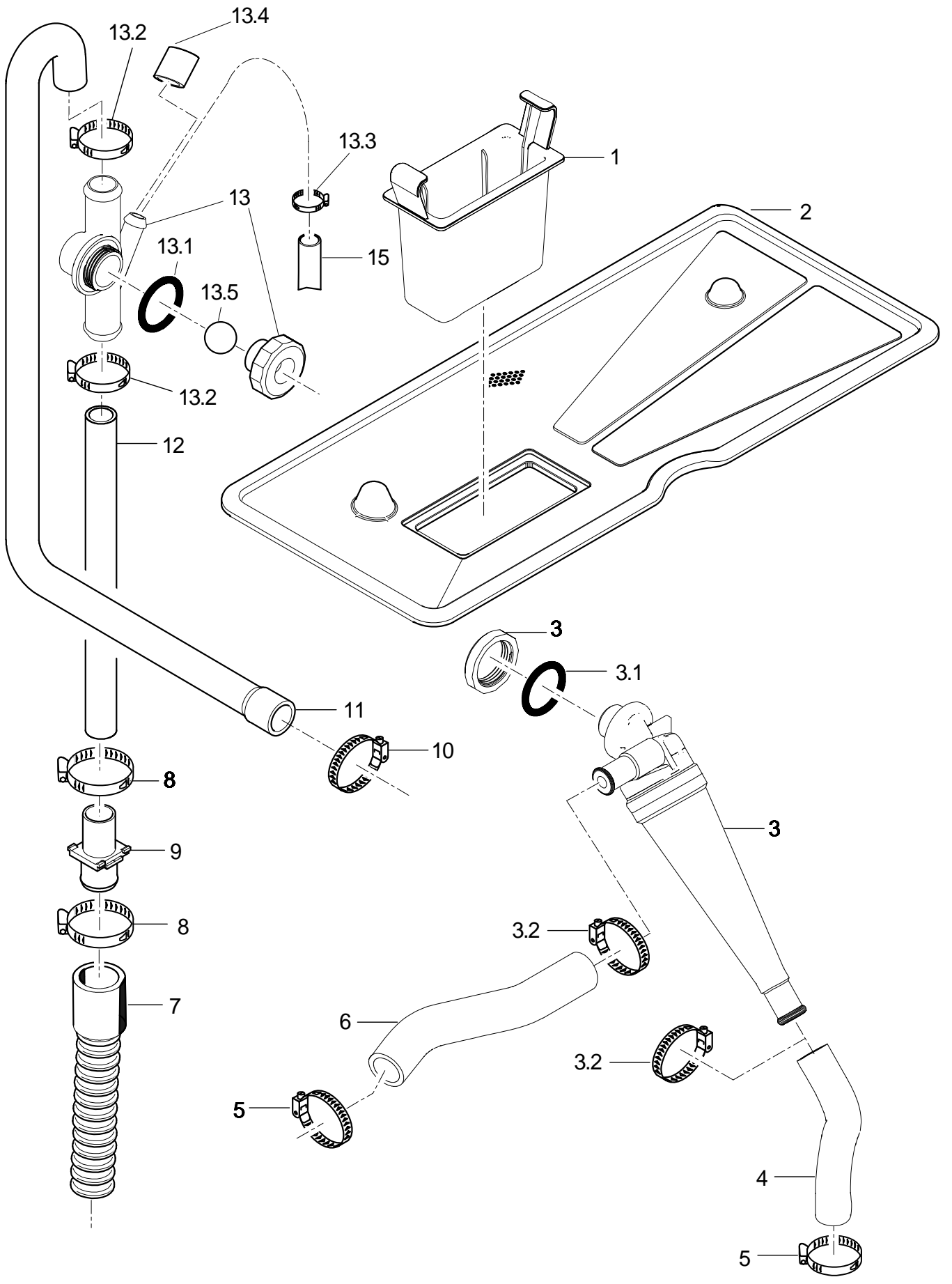

GS 302/315 60003530-01

GS 302 - GS 310 - GS 315

Water drain, Mediamat Cyclo

Item.	Designation	Parts no.	Pc.	Notes
1	Filter cassette	60003039		
2	Kit flat filter	60004142		
3	Mediamat Cyclo kit	60003513		
3.1	O-ring; 17 X 3	27 07 068		
3.2	Hose clamp; D12-22 X 9	30000711	2	
4	Moulded hose; DN12,5 X 2,0	60003165		
5	Hose clamp; D12-22 X 9	30000711		
6	Industrial hose; DN13 X 3,5	40 02 035		145 mm; "By-the-metre" goods
7	Drain hose; 1500 LG	60003738		
7	Drain hose; 2000 LG	60003759		
7	Drain hose; 2500 LG	60000396		
8	Hose clamp; D20-30 X 12	28 02 109		
9	Double nipple; D21,80 X 49; D19	60003399		
10	Hose clamp; D20-30 X 12	28 02 109		
11	Moulded hose; DN18 X DN22; 814	60003281		up to machine no.: 496 112
11	Moulded hose; DN18 X DN22 X 2,25	60004004		from machine no.: 496 113
12	Moulded hose; D18 X 2,5; 500	62004028		
13	Deaeration kit	60003514		
13.1	O-ring; 24 X 3,0	27 07 087		
13.2	Hose clamp; D20-30 X 12	28 02 109	2	
13.3	Hose clamp; D10-16 X 9	28 02 307		
13.4	Round cap; D11 X 20	35 03 029		
13.5	Ball; D14	28 01 508		
15	Moulded hose; DN10 X 2,0 X 1350	60003280		from built-in water softener ; GS 302, GS 315

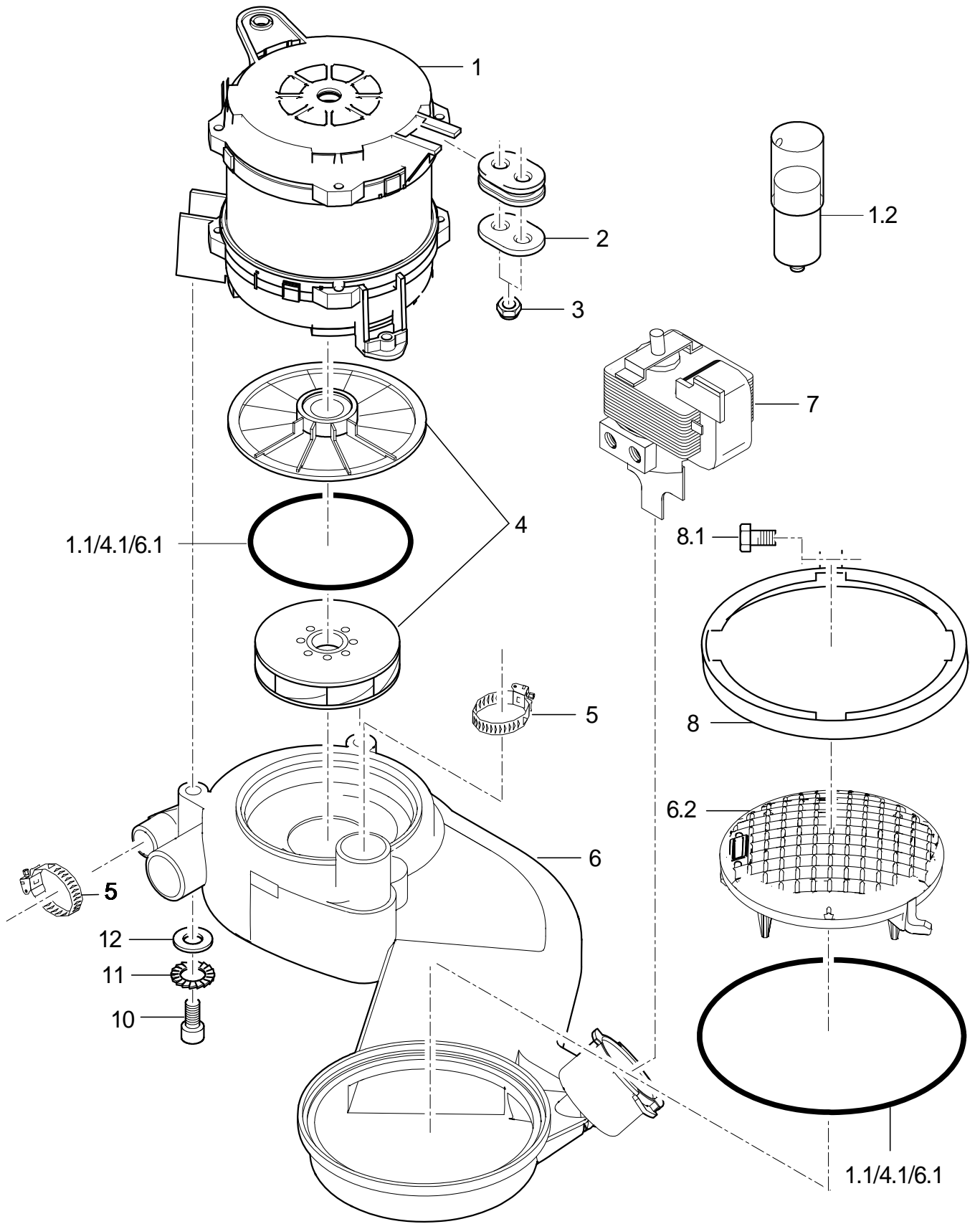

GS 302/315 60003531-00

GS 302 - GS 310 - GS 315

Wash pump

Item.	Designation	Parts no.	Pc.	Notes
1	Pump motor kit; 230-240V/50-60HZ	60003595		we recommend ordering the set of pump running wheels, as well, when the motor is replaced
1	Pump motor kit; 200V/50-60HZ	60003596		we recommend ordering the set of pump running wheels, as well, when the motor is replaced
1.1	Sealing for pump system kit	60003591		
1.2	Capacitor; 10YF 400V; D35 X 80	31 13 120		
1.2	Capacitor; 12YF 400V;	31 13 122		Japan
2	Spacer washer; 1,25 X 18 X 28	60003298		
3	Hexagonal nut self securing; M5	21 05 302	4	
4	Impeller with sealings kit; D92	60003592		50 Hz
4	Impeller with sealings kit; D75	60003593		60 Hz
4.1	Sealing for pump system kit	60003591		
5	Hose clamp; D32-52 X 12	28 02 110	2	
6	Collector kit; WASCHSYSTEM UNT.+OBEN	60003620		
6.1	Sealing for pump system kit	60003591		
6.2	Filter insert	60003259		
7	Drain pump; 220-240V/50HZ	30012591		
7	Drain pump; 200V/50HZ;220-240V/60H	31 02 493		
7	Drain pump; 200V/60HZ	31 02 495		
8	Pump clip	62003437		
8.1	Hexagon screw; M5 X 40; A70	20 01 329		
10	Cylinder head screw; M5 X 20; 8,8	20 09 337	3	
11	Serrated lock washer; A-5,3	22 02 316	3	
12	Washer; D5,3 X D10 X 1,0	22 01 300	3	

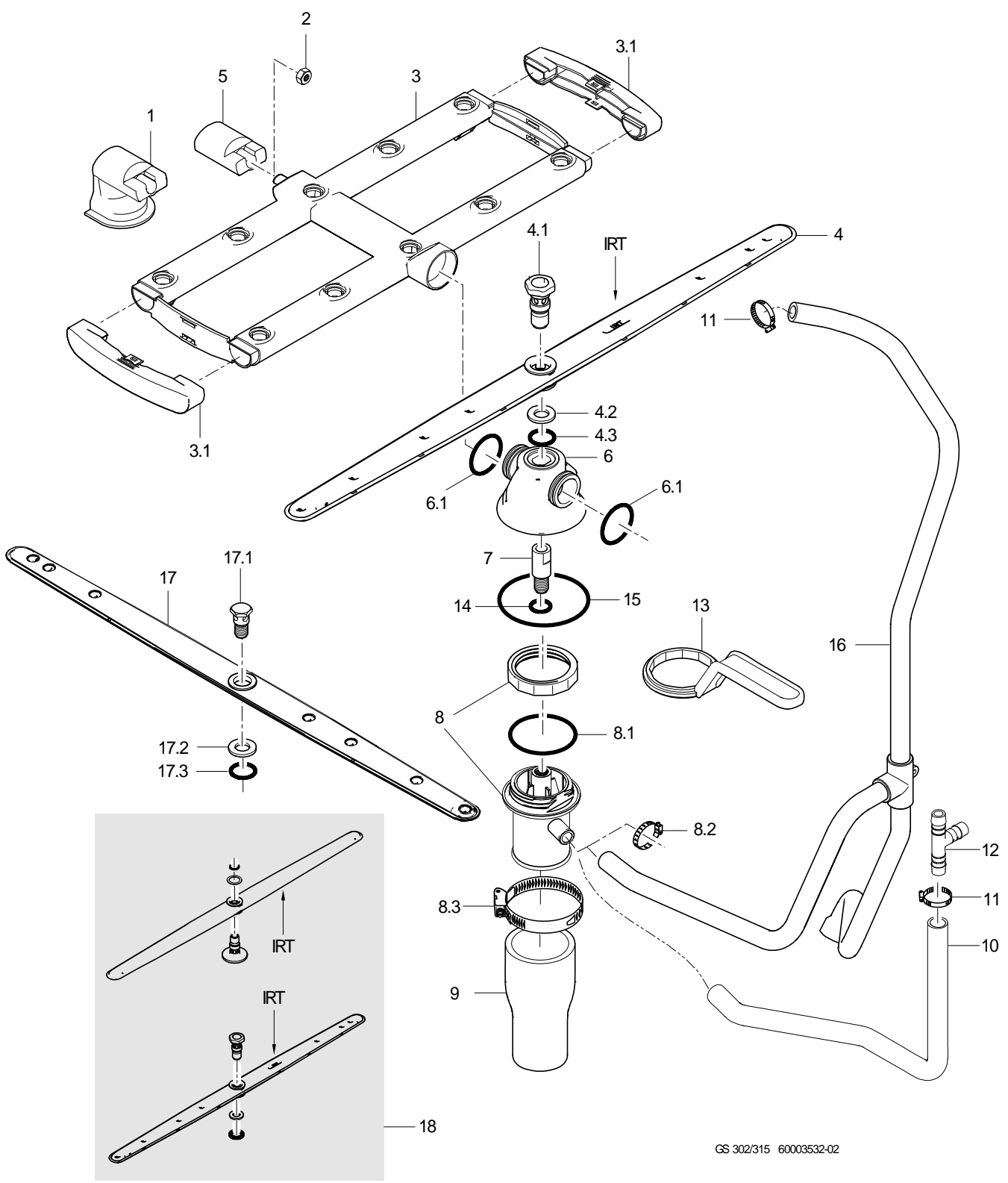

GS 302/315 60003532-02

GS 302 - GS 310 - GS 315

Bottom washing/rinsing system

Item.	Designation	Parts no.	Pc.	Notes
1	Wash unit support; 70,70 LG	60003435		no longer deliverable; replaced by: Kit flat filter 60004142 (incl. wash unit support)
2	Ratchet nut; M5	21 01 310	2	
3	Wash unit cpl.; 10 DÜSEN; 461 LG	60003803	2	
3.1	End piece; 31,50 X 152	60003802		
4	Rotating rinse arm, min. 2.4 l	61006612		from machine no.: 548 506; For machines with reduced rinse water volume
4.1	Rotary arm screw; M12 X 36; SW19	60004123		
4.2	Washer; D12,5 X D24 X 2,5	60003386		
4.3	O-ring; 10 X 2,5	30000723		
5	Wash unit support; 58,04 LG	60002999		
6	Distributor top kit	60003516		
6.1	Seal ring; D29,3 X D33,8 X 2,5	60004276	2	
7	Revolving rinse arm spindle; D16 X 44,5; M12	60003043		
8	Distributor bottom kit	60003518		
8.1	O-ring; 56 X 3,0	27 07 086		
8.2	Hose clamp; D12-22 X 9	30000711	2	
8.3	Hose clamp; D50-70 x 12	30001243		
9	Reducing hose; DN33 X DN46; 97	60004591		
10	Industrial hose; DN13 X 3,5	40 02 035		460mm; "By-the-metre" goods
11	Hose clamp; D12-22 X 9	30000711		
12	Hose T-connecting piece; D15 X D15 X D15	70010598		Pressure boiler
13	Double hex ring spanner; SW61,5	60003376		
14	O-ring; 10 X 1	27 07 054		
15	O-ring; 66 X 2,5	27 07 011		No longer has to be installed
16	Rinse manifold	60003831		Pressure-independent boiler
17	KIT REVOLVING RINSE ARM WITH 7 JETS; 7 DÜSEN	60003515		up to machine no.: 548 505
17.1	Revolving arm screw; M12 X 30; SW19	60003045		no longer deliverable; up to mach. no.: 496 628 replaced by 60003515
17.1	Rotary arm screw; M12 X 36; SW19	60004123		from machine no.: 496 629
17.2	Washer; D12,5 X D24 X 2,5	60003386		
17.3	O-ring; 10 X 2,5	30000723		
18	Rotating rinse arm conversion, min. 2.4 l; GS215; GS300; GS502	61006613		up to machine no.: 548 505; For machines with non pressurised boilers

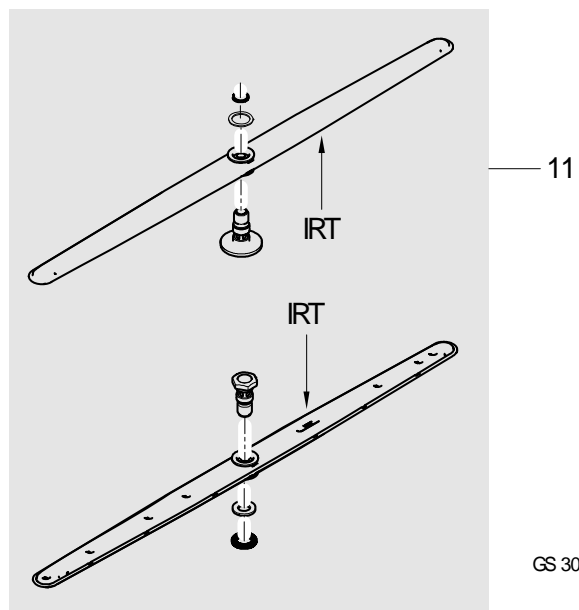
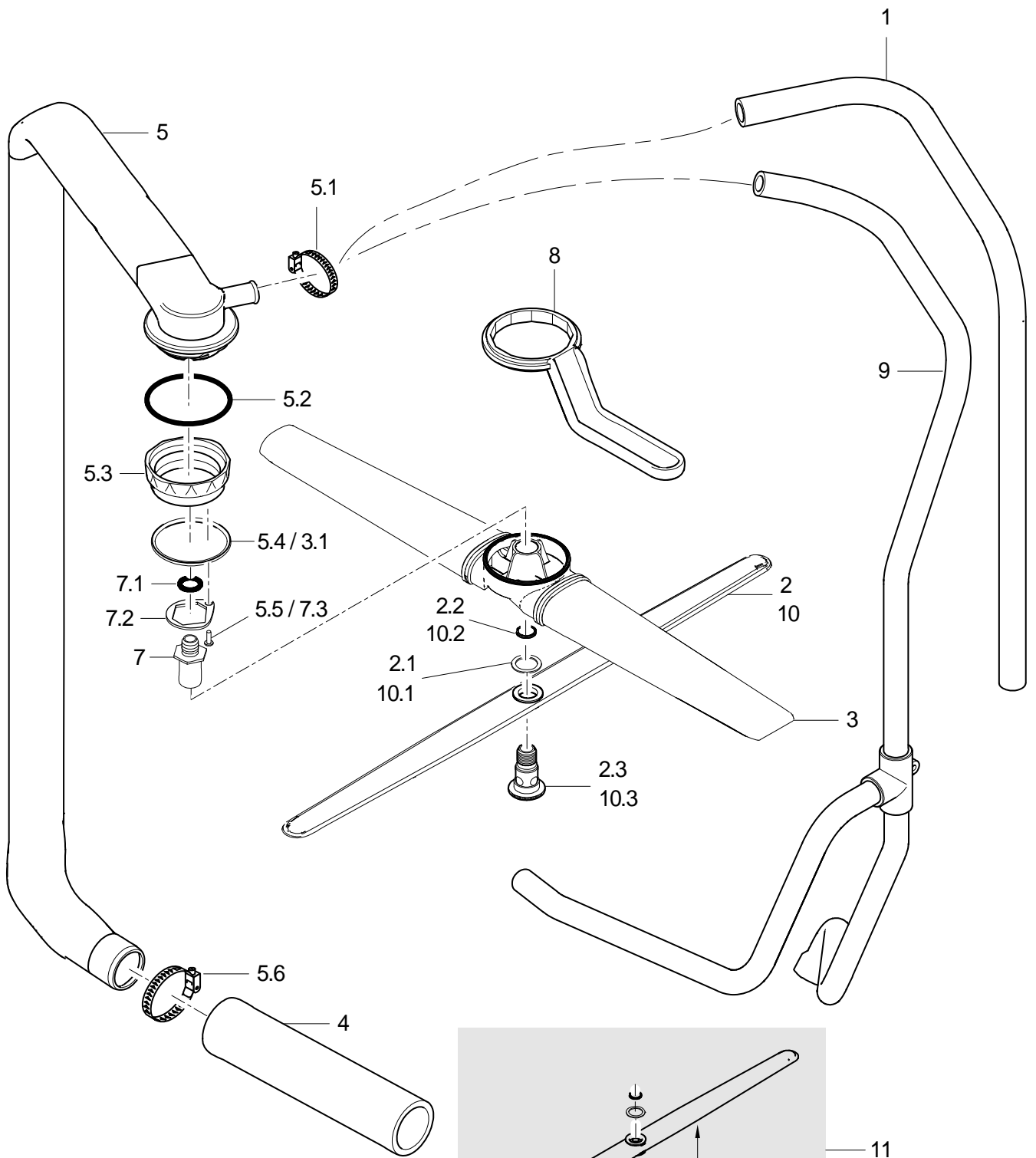

GS 302/315 60003533-02

GS 302 - GS 310 - GS 315

Top washing/rinsing system

Item.	Designation	Parts no.	Pc.	Notes
1	Moulded hose; DN12,5 X DN14 X 3,5	60003160		Pressure boiler
2	Rotating rinse arm, min. 2.4 l	61006612		from machine no.: 548 506; For machines with reduced rinse water volume
2.1	Rotary arm screw; M12 X 36; SW19	60004123		
2.2	Washer; D12,5 X D24 X 2,5	60003386		
2.3	O-ring; 10 X 2,5	30000723		
3	SET OF ROTARY ARMS WASHING	60003520		
3.1	SEAL RING; D53,4 X D57,8 X 2,0	60003021		
4	Hose; DN33 X 4,0; 225	60004843		adapt
5	Washing distributor top kit	60003519		
5.1	Hose clamp; D12-22 X 9	30000711		
5.2	O-ring; 56 X 3,0	27 07 086		
5.3	LOCK NUT; S54 X 4; D57	60003005		
5.4	SEAL RING; D53,4 X D57,8 X 2,0	60003021		
5.5	Sheet metal screw; ST 3,5 X 9,5	20 20 305		
5.6	Hose clamp; D32-52 X 12	28 02 110		
7	REVOLVING RINSE ARM SPINDLE KIT	60003616		
7.1	O-ring; 10 X 2,5	30000723		
7.2	Fixing plate; 1,5 X 28 X 32,3	61006076		
7.3	Sheet metal screw; ST 3,5 X 9,5	20 20 305		
8	Double hex ring spanner; SW61,5	60003376		
9	Rinse manifold	60003831		Pressure-independent boiler
10	KIT REVOLVING RINSE ARM WITH 7 JETS; 7 DÜSEN	60003515		up to machine no.: 548 505
10.1	Washer; D14,10 X D20 X 1,0	60003487		
10.2	LOCKING RING; D12 X 0,8	60003023		
10.3	Revolving arm screw; M12 X 32,3; D25	60003821		no longer deliverable; up to mach. no.: 496 628 replaced by 60003515
10.3	Revolving arm screw; M12 X 34,9; D35	60004125		from machine no.: 496 629
11	Rotating rinse arm conversion, min. 2.4 l; GS215; GS300; GS502	61006613		up to machine no.: 548 505; For machines with non pressurised boilers

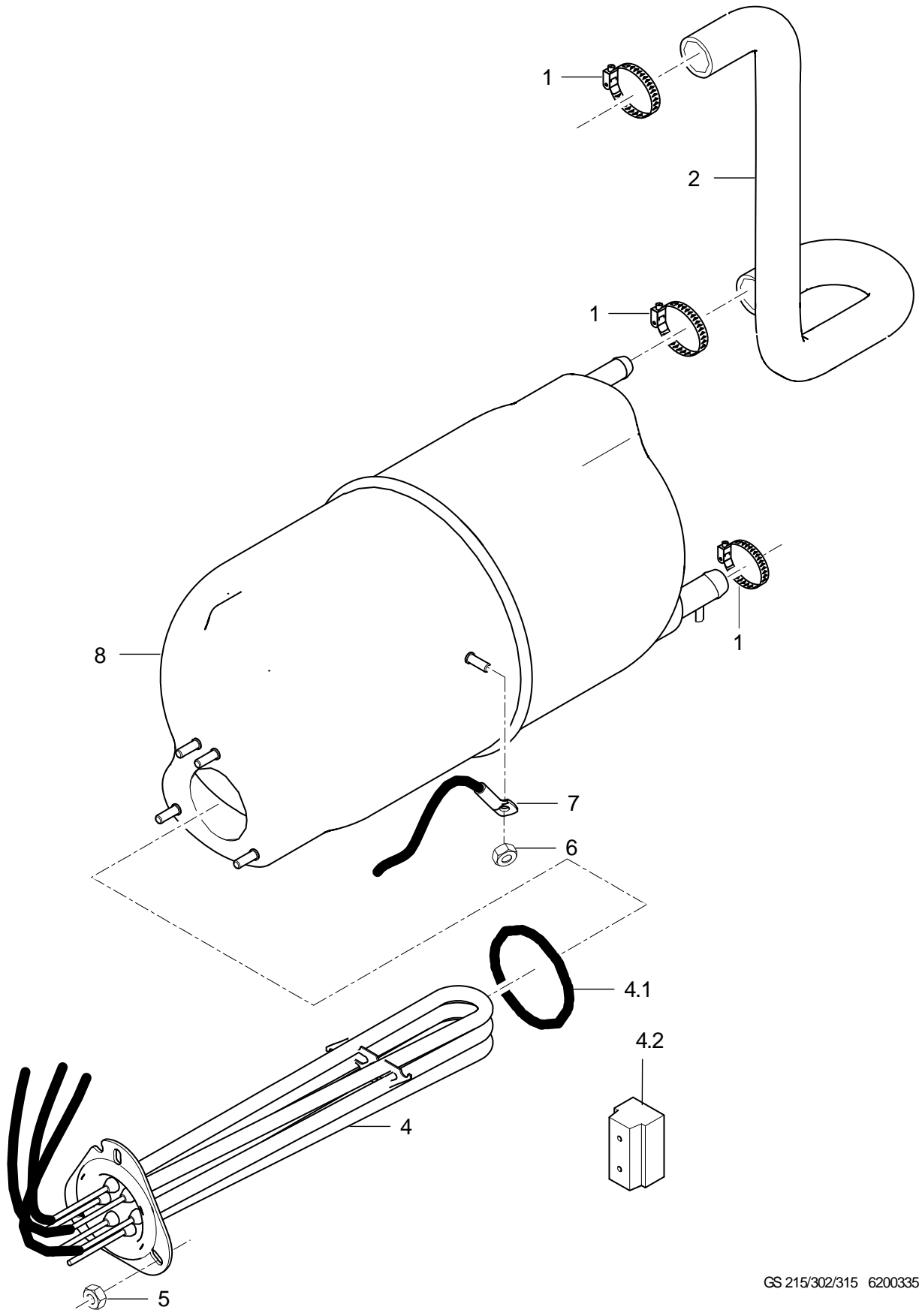

GS 215/302/315 62003359-00

GS 302 - GS 310 - GS 315

Pressure boiler GS 302, GS 315

Item.	Designation	Parts no.	Pc.	Notes
1	Hose clamp; D12-22 X 9	30000711		
2	Moulded hose; DN12,5 X 3,5 X 286	60003162		
4	Heater with fuse; 5.0kW; 3 X 380-420V	60003598		Rotary current (star connection)
4	Heater with fuse; 5.0kW; 3 X 240V DREIECK	60003599		Rotary current (delta connection)
4	Heater with fuse; 5.0kW; 3 X 200-208V STERN	60003600		
4	Heater with fuse; 5.0kW; 3 X 440-460V STERN	60003833		
4	Heater with fuse; 3.5kW; 3 X 400V STERN	60003602		Switzerland (fuse protection 10A)
4	Heater with fuse; 4.0kW; 1 X 220-240V	60003604		Alternating current (fuse protection 25A; UK)
4	Heater with fuse; 2.6kW; 1 X 220-240V	60003605		Alternating current (fuse protection 16A)
4	Heater with fuse, 2.6kW; 1 X 208V	60003607		Alternating current (fuse protection 20A; Japan, USA)
4	Heater with fuse; 1.8kW; 1 X 220-240V	60003610		Alternating current (fuse protection 13A; UK)
4.1	O-ring; 46 X 6,0	27 07 085		
4.2	Appliance terminal G10/4; 4-POLIG; 10QMM	31 09 227		
5	Hexagonal nut; M5	21 01 203	3	
6	Ratchet nut; M5	21 01 310		
7	Thermal sensor kit 1700mm	80003804		with heat-conducting foil
8	Pressure boiler cpl.	60002916		

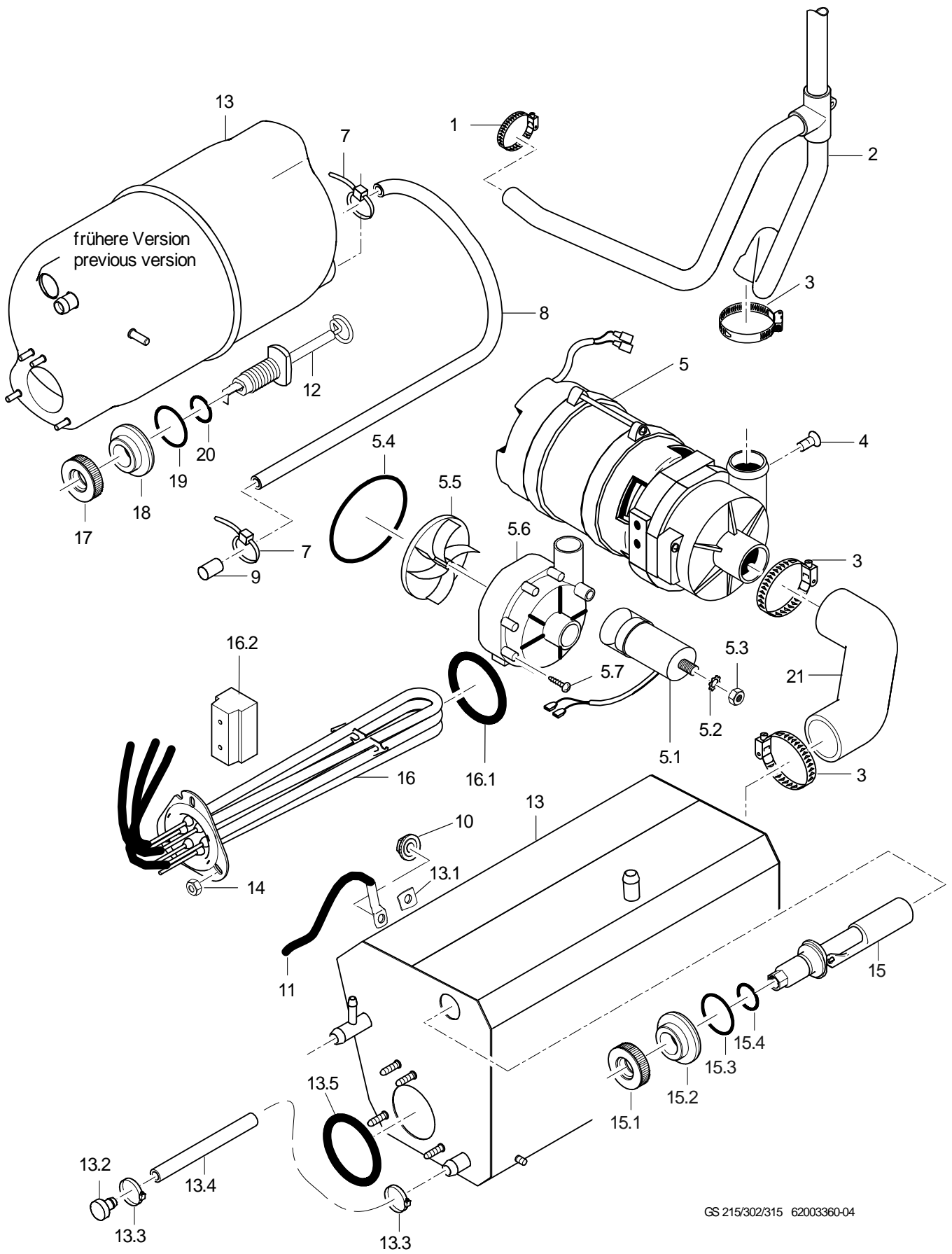

GS 302 - GS 310 - GS 315

Pressure-independent boiler

Item.	Designation	Parts no.	Pc.	Notes
1	Hose clamp; D12-22 X 9	30000711		
2	Rinse manifold	60003831		
3	Hose clamp; 25 - 40MM / 12MM	30002612		
4	Countersunk screw; M6 X 16	20 12 319	2	
5	PUMP 0,20KW 2/1; 1/1; 200-240V/1/50-60HZ	31 02 561		Repair recommended only for pump housings with 7 screws
5.1	Capacitor; 4 MIKRO F / 400V	31 13 171		
5.1	Capacitor; 5 MIKRO F	31 13 099		
5.2	Spring washer; B8	23 03 301		
5.3	Hexagonal nut; M8	21 01 305		
5.4	Cord; D=78 X 3; SHOR 50-55;	40 04 023		
5.5	Pump impeller with counter ring; UP60/UP30 - 50HZ	31 02 466		50 Hz
5.6	Pump housing; D=80,5MM	31 02 519		
5.7	Screw for pump housing; D4X35 PT	31 01 118	7	
7	Cable tie; 100 X 2,5	31 20 175		
8	Hose; DN5 X 1,5	40 01 024		900 mm; "By-the-metre" goods
9	Bolt; D6 X 30	70200383		
10	Ratchet nut; M5	21 01 310		
11	Thermal sensor kit 1700mm	80003804		with heat-conducting foil
12	Floating switch installation set	55 28 255		Replacement for: 5528292 (Built-in electrode)
12.1	Nut; M14 X 2, D26,8 X 8	60003989		
12.2	Ring; D14,3 X D32 X 11	60003872		
12.3	O-ring; 23 X 3,5	27 07 093		
12.4	O-ring; 11,11 X 1,78	27 07 079		
13	Pressure-independent boiler	60004174		includes all necessary hoses
13.1	Heat conducting foil with hole; 0,25 X 12 X 15	61005285		
13.2	Plug; D24 X D13,1 X 27	70007962		
13.3	Hose clamp; D12-22 X 9	30000711		
13.4	Hose; D10 X 2	30000863		450 mm; "By-the-metre" goods
13.5	O-ring; 46 X 6,0	27 07 085		
14	Hexagonal nut; M5	21 01 203	3	
15	Floating switch installation set	55 28 255		
15.1	Nut; M14 X 2, D26,8 X 8	60003989		
15.2	Ring; D14,3 X D32 X 11	60003943		
15.3	O-ring; 24 X 3,0	27 07 087		
15.4	O-ring; 11,11 X 1,78	27 07 079		

For missing items, see next page

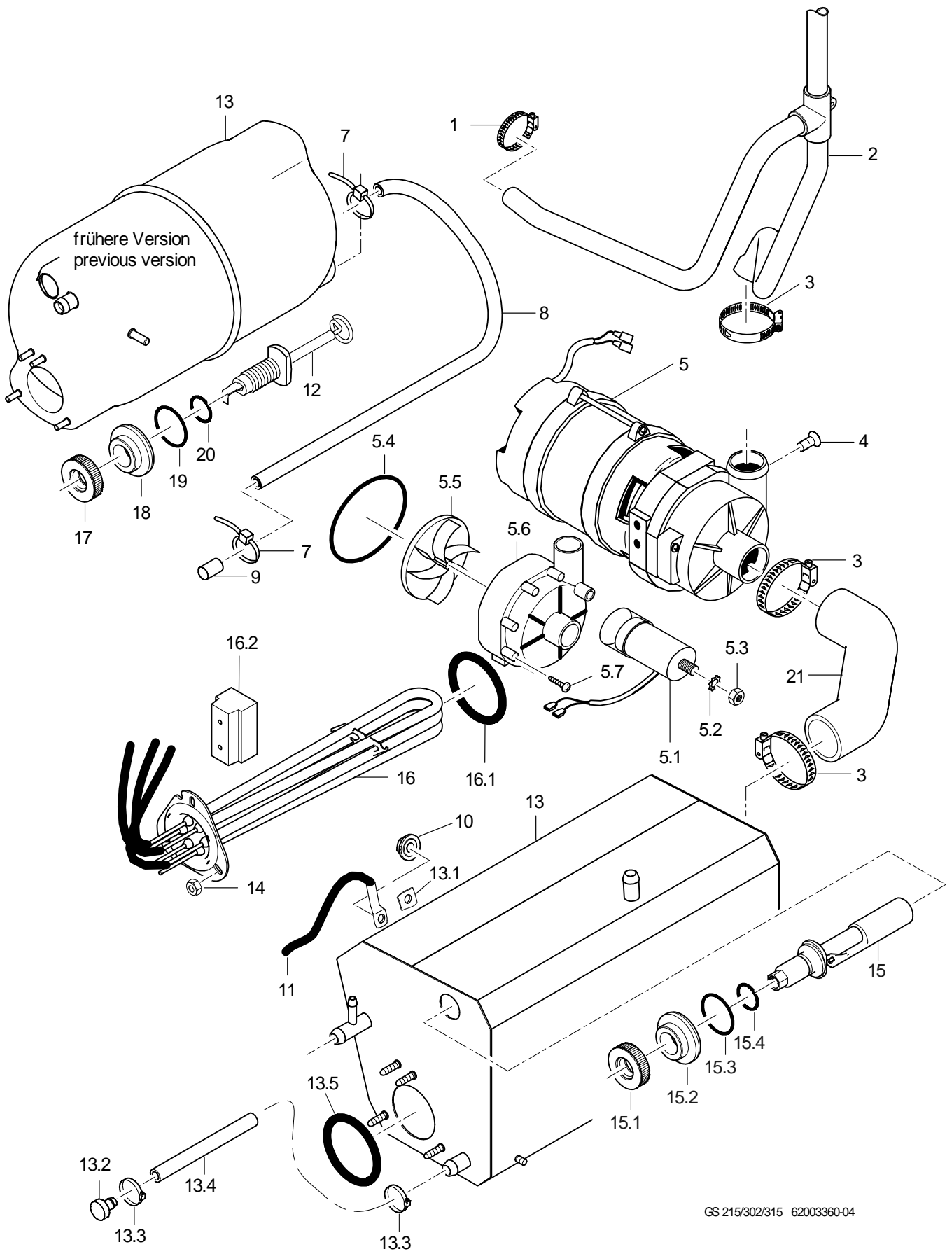

GS 302 - GS 310 - GS 315

Pressure-independent boiler

Item.	Designation	Parts no.	Pc.	Notes
16	Heater with fuse; 5.0kW; 3 X 380-420V	60003598		Rotary current (star connection)
16	Heater with fuse; 5.0kW; 3 X 240V DREIECK	60003599		Rotary current (delta connection)
16	Heater with fuse; 5.0kW; 3 X 200-208V STERN	60003600		
16	Heater with fuse; 5.0kW; 3 X 440-460V STERN	60003833		
16	Heater with fuse; 3.5kW; 3 X 400V STERN	60003602		Switzerland (fuse protection 10A)
16	Heater with fuse; 4.0kW; 1 X 220-240V	60003604		Alternating current (fuse protection 25A; UK)
16	Heater with fuse; 2.6kW; 1 X 220-240V	60003605		Alternating current (fuse protection 16A)
16	Heater with fuse, 2.6kW; 1 X 208V	60003607		Alternating current (fuse protection 20A; Japan, USA)
16	Heater with fuse; 1.8kW; 1 X 220-240V	60003610		Alternating current (fuse protection 13A; UK)
16.1	O-ring; 46 X 6,0	27 07 085		
16.2	Appliance terminal G10/4; 4-POLIG; 10QMM	31 09 227		
17	Nut; M14 X 2, D26,8 X 8	60003989		
18	Ring; D14,3 X D32 X 11	60003872		
19	O-ring; 24 X 3,0	27 07 087		
20	O-ring; 11,11 X 1,78	27 07 079		
21	Moulded hose; DN25 X 4,0; 140	60002973		

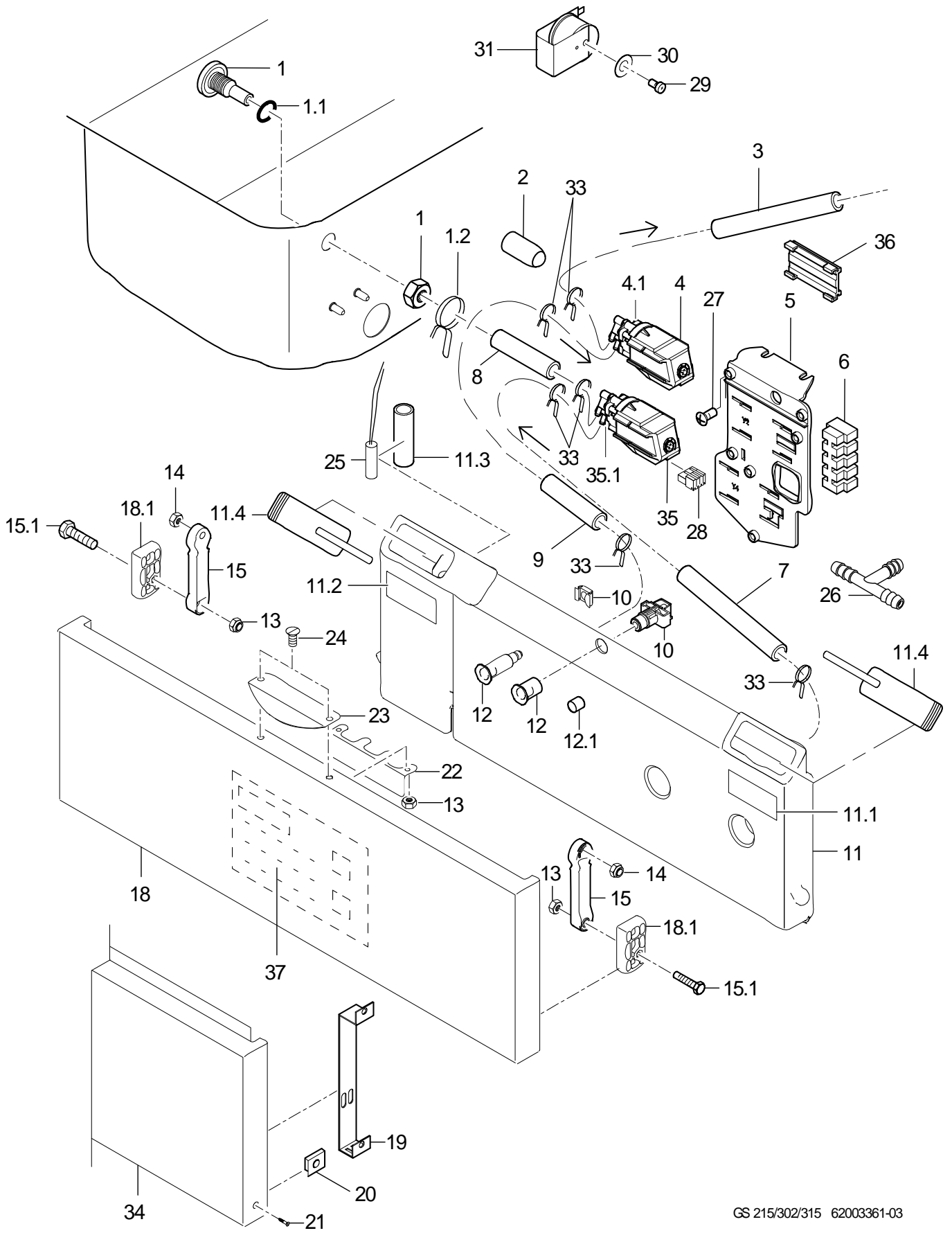

GS 215/302/315 62003361-03

GS 302 - GS 310 - GS 315

Dosage

Item.	Designation	Parts no.	Pc.	Notes
1	Dosing nipple set; M10 X 29; SW5	61005883		
1.1	O-ring; 10 X 2,5	30000723		
1.2	Wire hose clamp; D8,6 X 1	28 02 348		
2	End cap; D5,7 X 25,4	35 06 180		
3	Hose; DN5 X 1,5	40 01 024		900 mm; "By-the-metre" goods
4	Rinse aid pump Fluidos DB; 115-240V/50-60HZ	31 02 598		
4.1	Head Fluidos DB "Rinse Aid"	31 02 600		
5	Adapter plate; 1,5 X 80 X 100	60003688		
6	Binding post; 5-POLIG; 6QMM; 56,5LG	31 09 230		for connecting external dispenser
7	Hose; DN5 X 1,5	40 01 024		600 mm; "By-the-metre" goods
8	Hose; DN5 X 1,5	40 01 024		300 mm; "By-the-metre" goods
9	Hose; DN5 X 1,5	40 01 024		800 mm; "By-the-metre" goods
10	Captive nut; M8	21 13 006		up to machine no.: 493 480
10	Stud bolt; M8 X 37; M12	60003658		from mach. no. 493 481
11	Detergent container	60003747		
11.1	Label detergent; 0,2 X 28 X 65	60003330		
11.2	Label -Rinse Aid-; 0,2 X 28 X 65	60003310		
11.3	Hose; DN5 X 1,5	40 01 024		50 mm; "By-the-metre" goods
11.4	Cover	60003974		retrofitable; for both sides
12	Magnet support	60003643		up to machine no.: 493 480
12	Magnet support	60003952		from mach. no. 493 481
12.1	Magnet; D10 X 10	31 24 191		
13	Hexagonal nut self securing; M4	21 05 300		
14	Hexagonal nut self securing; M5	21 05 302	3	
15	Set of levers	60003778		
15.1	Hexagon screw; M4 X 18	20 01 320		
18	Set of detergent flaps	60004140		with detergent, freshwater rinse dispenser
18.1	Profile; 12,5 X 28 X 50	60003569	2	
19	Bracket; 1,25 X 25 X 243,08	60003823		
20	Sheet metal nut; B 3,9	21 17 301	4	
21	Sheet metal screw; ST 3,9 X 11	30011208	4	
22	Elbow; 1,0 X 43 X 100	60003633		
23	Handle kit	60003650		
24	Countersunk screw; M4 X 10	20 12 312		
25	Magnetic switch; 25,5 X D5,75; 2250 LG	31 24 240		
26	T-hose socket; D6	29 06 516		Additional equipment
27	PT screw; KB 60 X 12	20 17 308	2	
28	Macro-module plug 5, 4-pole; 250V/4KV/3; 2,5MM2	31 12 094		
29	Lens head screw; M3 X 10	20 10 004		

For missing items, see next page

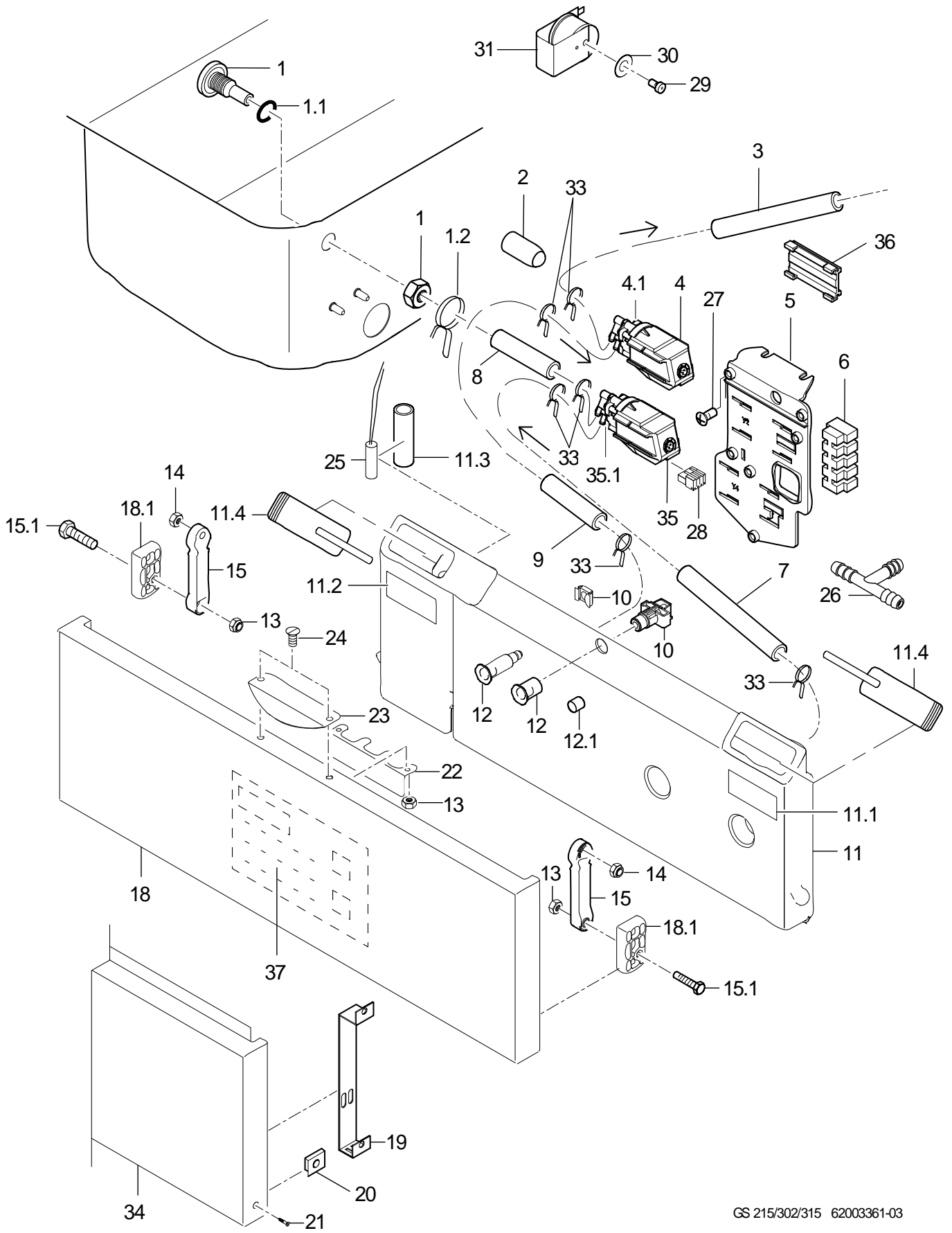

GS 215/302/315 62003361-03

GS 302 - GS 310 - GS 315

Dosage

Item.	Designation	Parts no.	Pc.	Notes
30	Washer; D5,3 X D15 X 1,2	22 05 301		
31	Buzzer; 230VAC;75DB;23X30,5MM	31 13 133		Additional equipment
31	Set of acoustical level indicators; WPS MAX. VORHANDEN	55 28 281		with max. WPS version
31	Set of acoustical level indicators; WPS MAX.NICHT VORHAND.	55 28 282		with min. WPS version
33	Wire hose clamp; D8,6 X 1	28 02 348		
34	Front panelling, complete	60003827		without detergent, freshwater rinse dispenser; up to mach. no. 480028; order too: 2x60003823
35	Detergent pump Fluidos DT; 115-240V/50-60HZ	31 02 597		
35.1	Head Fluidos DT "Detergent"	31 02 599		
o.P.	Fluidos DT "Detergent" retrofit kit	30000005		GS 302, GS 315
36	Adapter; 11,4 X 33,5 X 57,5	80003775		from machine no.: 1001846
37	Caution + notice sticker	28 03 433		

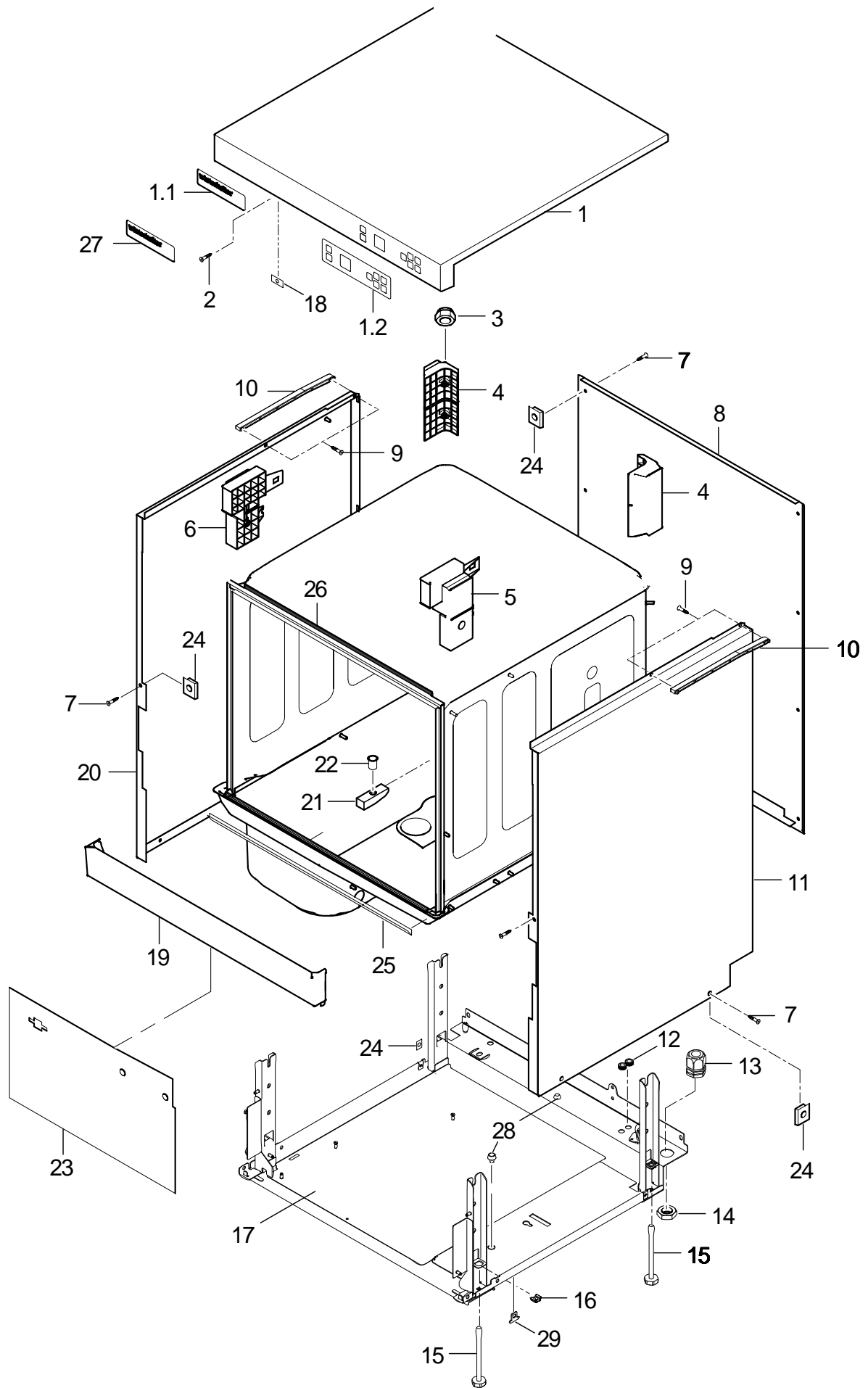

GS 302/315 60003534-00

GS 302 - GS 310 - GS 315

Chassis, container and panelling

Item.	Designation	Parts no.	Pc.	Notes
1	Cover plate kit	60003521		
1.1	Plate -Winterhalter GS 302-; 0,175 X 35 X 126	60004381		
1.1	Plate -Winterhalter GS 315-; 0,175 X 35 X 126	60004382		
1.2	Pad -Operating Panel-; 0,175 X 50 X 180	31 24 223		
2	Sheet metal screw; ST 3,9 X 13	20 21 302	2	
3	Ratchet nut; M5	21 01 310		
4	Support corner rear	60003010	2	
5	Support corner front right	60003009		
6	Support corner left	60003008		
7	Sheet metal screw; ST 3,9 X 11	30011208	16	
8	Rear cover	60004561		GS 302; GS 310
8	Rear cover	60004562		GS 315
9	Sheet metal screw; ST 3,9 X 13	20 21 302	2	
10	Slide for cover panel; 250,50 LG	60003501		
11	Panel right	60003343		
12	Hose nozzle; 6,25 X D15; D8,5	61004890	3	
13	Cable gland; M25 X 1,5;9-17MM;IP68	31 10 153		
14	Hexagonal nut; M25 X 1,5 X 6,0; SW32	31 10 163		
15	Adjustable foot; M8 X 129; SW24	60004274	4	
16	Captive nut; M8	21 13 006	4	
17	Bottom plate, complete	60003441		up to machine no.: 473 308
17	Base plate; 2,0 X 444,5 X 479	60003749		from machine no.: 473 309
18	Plate nut; B 3,9	21 17 100	2	
19	Panel; 1,0 X 149,23 X 703,38	60003754		
20	Panel left	60003342		
21	Rack stop; 18 X 20 X 65	60003630		GS 315
22	Truss-head screw with retaining ring; M5 X 15	70005097		GS 315
23	Protective film; 0,185 X 196 X 330	60003838		retrofittable
24	Sheet metal nut; B 3,9	21 17 301	16	
25	Rubber profile; 6,0 X 12 X 570	60003847		
26	Sealing tape; 9 X 2 X 10000	30001091	1	1 roll = 1 m
27	Plate -Winterhalter GS 310-; 0,175 X 35 X 126	60004383		GS 310
28	Buffer; D8 X 14	40 06 023	2	
29	Latch; 1,5 X 18,9 X 23,9	60003732	2	
o.P.	Set of vapour protectors, cpl.	80002865		Additional equipment

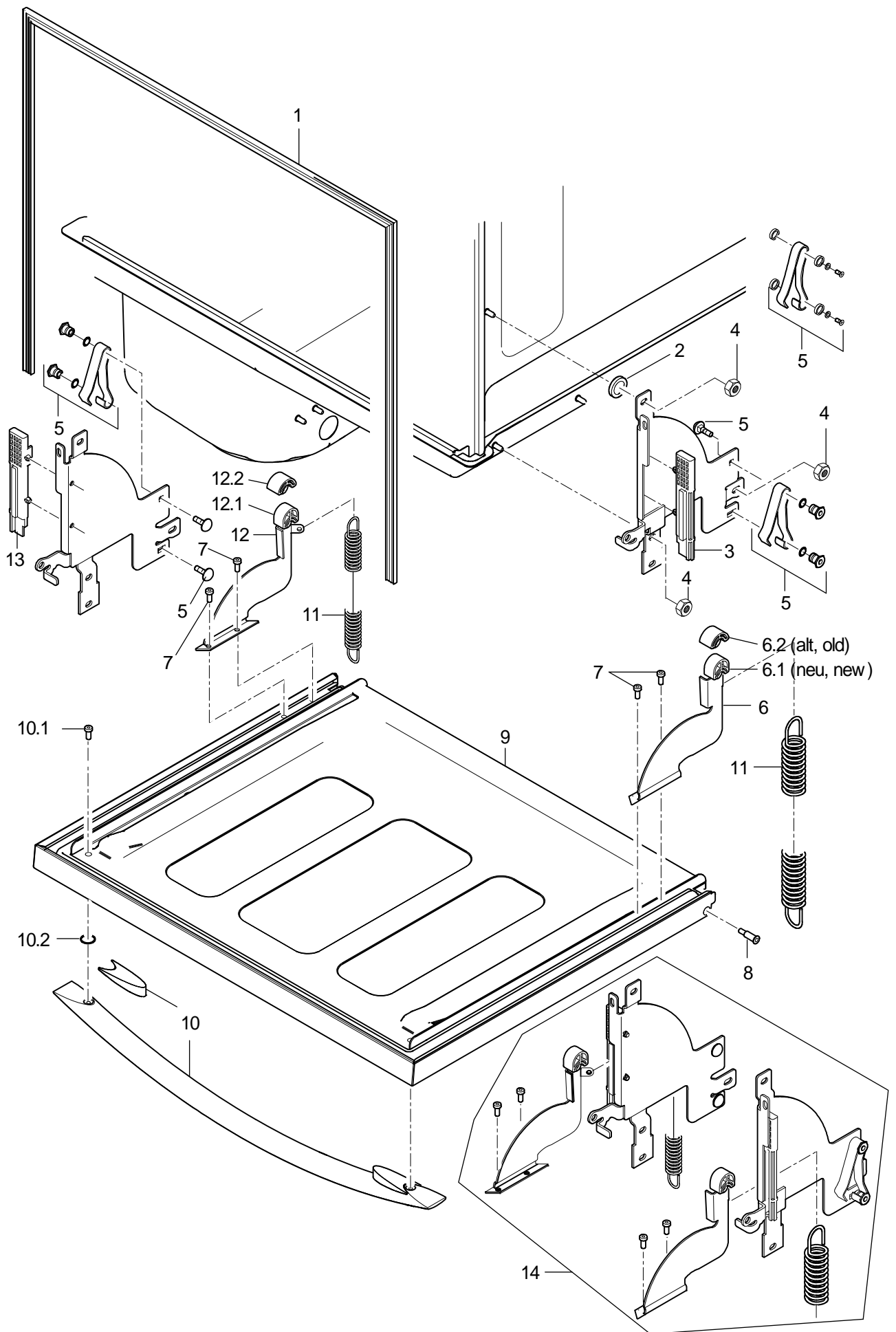

GS 302/310/315 60003535-02

GS 302 - GS 310 - GS 315

Door

Item.	Designation	Parts no.	Pc.	Notes
1	Kit door seal	30000317		
2	Washer; D5,3 X D15 X 1,2	22 05 301		
3	Right stop	60003411		
4	Hexagonal nut self securing; M5	21 05 302	3	
5	Leaf spring repair kit	60003744		for both sides; up to mach. no.: 496 855
5	Leaf spring repair kit	60003998		for both sides; from mach. no. 496 856
6	Brace right, offset, cpl.	60003995		incl. item 6.1 - 6.2
6.1	Sliding roller	60003870		
6.2	Sliding roller	60003214		
7	Cylindrical screw; M5 X 14,8; SW3	62003334	4	
8	Door bearing bolt; D9 X D7,0 X M5; SW4	60003147	2	
9	Door cpl.	60003014		without door handle
10	Door handle kit	60003522		
10.1	Lens head screw; M5 X 30	30000373	2	
10.2	O-ring; 6 X 2	27 07 012	2	
11	Tension spring; L0=193;L1=360;F1=82	60003697	2	
12	Brace left, offset, cpl.	60003994		incl. item 12.1 - 12.2
12.1	Sliding roller	60003870		
12.2	Sliding roller	60003214		
13	Left stop	60003410		
14	Hinge conversion kit 302	60003999		produced in series starting with machine no.: 496 856
o.P.	Silicone adhesive Elastosil E43; 90 ML	34 03 012		for door seals

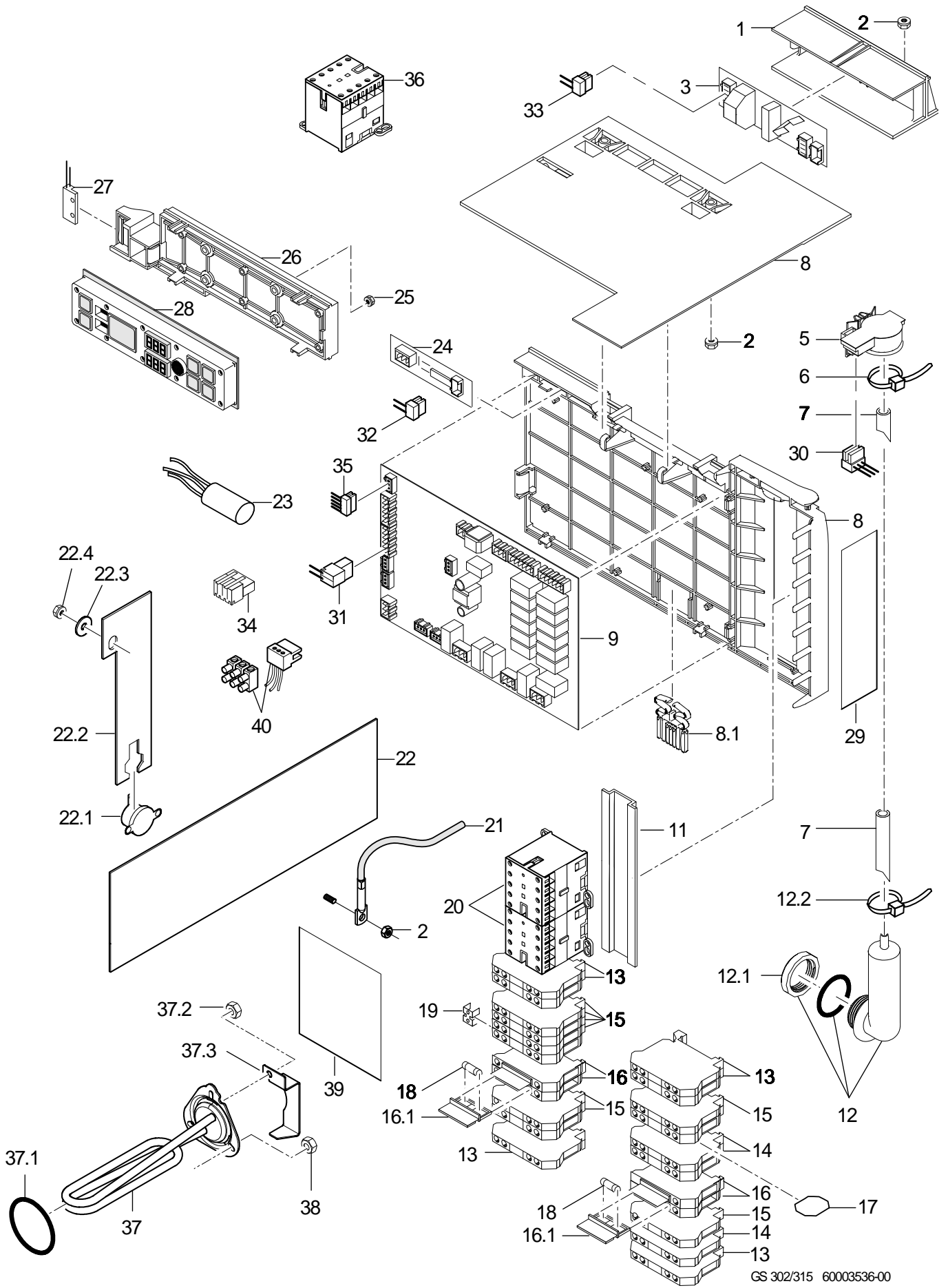

GS 302/315 60003536-00

GS 302 - GS 310 - GS 315

Electric parts

Item.	Designation	Parts no.	Pc.	Notes
1	Protective cover; SCHWARZ	60003541		
2	Ratchet nut; M5	21 01 310	4	
3	Soft start WSA4	31 13 180		
5	Pressure transmitter; 0-30MBAR;5VDC/0,5-3,5V	31 26 044		
6	Cable tie; 100 X 2,5	31 20 175		
7	Hose; DN5 X 1,5	40 01 024		860 mm; "By-the-metre" goods
8	Assembly plate	60003660		incl. item 8.1
8.1	Latch; SCHWARZ	60003356		
9	Programme control WPS MAX Kit; 180-265V; 50/60HZ	31 05 139		
11	Snap-on rail; 1,0 X 35 X 185	60003244		
12	Air chamber set	60003525		
12.1	Nut; D26,2 X 8,5; SW32	60004612		
12.2	Cable tie; 100 X 2,5	31 20 175		
13	UDK 4-PE double terminal	31 09 153	3	
14	UDK 4 double terminal	31 09 151		
15	UDK 4 BU double terminal	31 09 152		
16	Universal fuse clip	31 09 063	2	
16.1	Securing plug	31 09 072		
17	Isolating disc; 14 X 16	31 09 169		
18	Fine fuse, medium time lag; 250V; 4,0A; 5 X 20	31 11 123	2	has been reduced from 6.3A to 4.0A
19	Fixed bridge; 2-POLIG;	31 09 126		
20	Contacteur B7:3H 1 N/C contact; 220-255V/50-60HZ	31 04 154	2	
20	Contacteur B7:3H 1 N/C contact; 200V/50-60HZ	31 04 171	2	Japan; USA
20	Contacteur B7:3H:1Ö; 208V/50-60HZ	31 04 176	2	
21	Thermal sensor kit 1700mm	80003804		with heat-conducting foil
22	Foil heating element 600 watts; 230V, 310 X 115MM	60003653		
22	Foil heating element 600 watts; 208V, 310 X 115MM	60003654		Japan; USA
22.1	Safety thermostat; 185 GRAD C MAN.RÜCKST.	31 25 053		
22.2	Retainer; 1,0 X 35 X 110,7	60003939		
22.3	Washer; D5,3 X D15 X 1,2	22 05 301		
22.4	Hexagonal nut self securing; M5	21 05 302		
23	Radio interference suppression capacitor; 0,27MF + 2 X 27000PF	31 13 078		
24	Level sensor, electronic; 12V; 7MA; 80 X 20 MM	31 13 164		Pressure-independent boiler
25	Nut-and-washer assembly; M3	21 01 312	4	
26	Support for operating panel	60003350		
27	Magnetic switch; 32 X 14,9 X 6,9; 400LG	31 24 229		
28	Operating panel; 25 X 55 X 210	31 24 222		
29	Protective film; 0,185 X 52 X 195	60003764	2	retrofitable
30	Universal cable pressure transmitter; 3 X 0,34QMM; 1520 LG	82000120		

For missing items, see next page

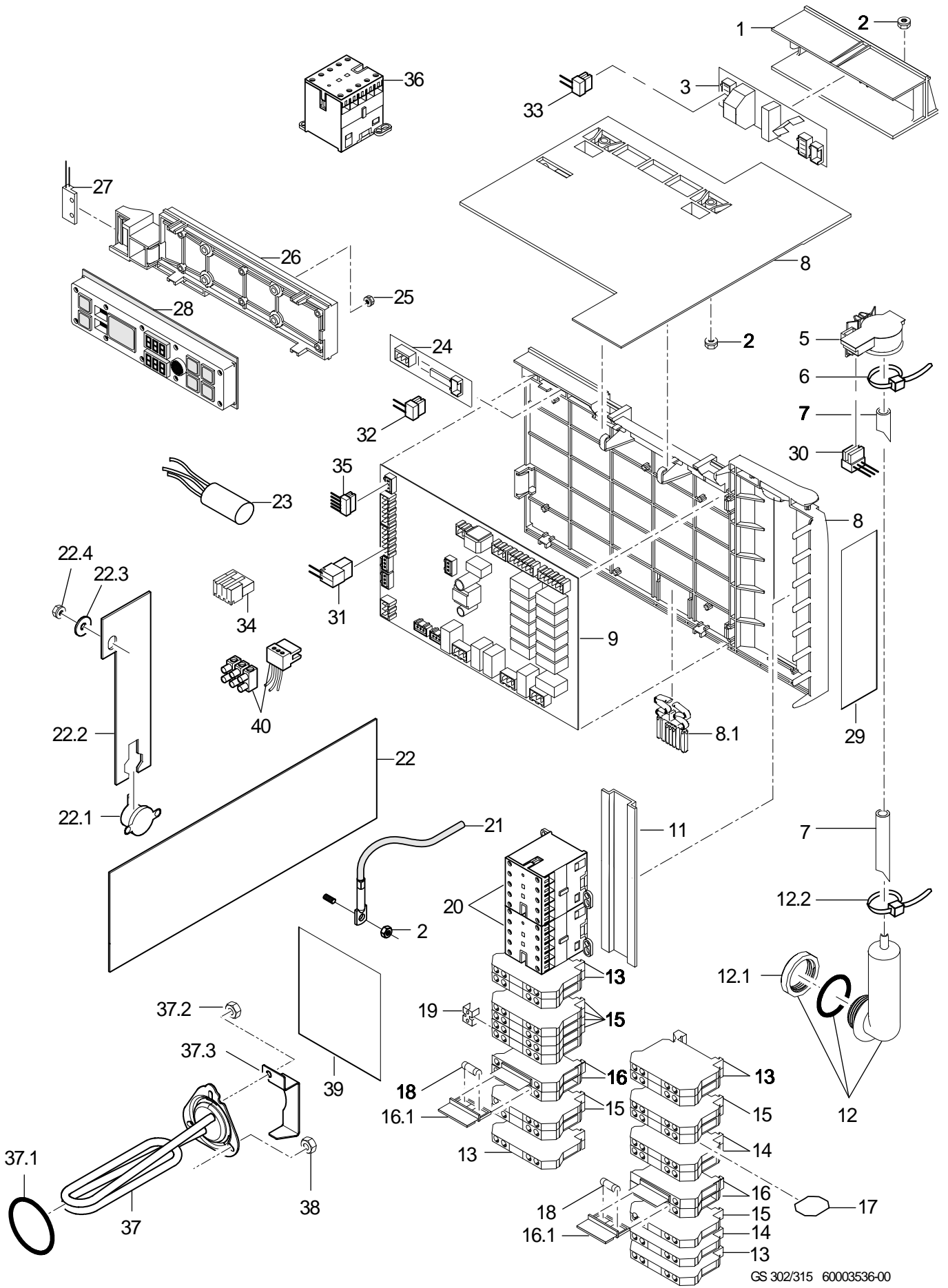

GS 302/315 60003536-00

GS 302 - GS 310 - GS 315

Electric parts

Item.	Designation	Parts no.	Pc.	Notes
31	Wiring loom; Water softener	60003185		GS 302, GS 315
32	Cable for level sensor; 2 X 0,34QMM	60003175		
33	Wiring loom; Soft start	60003475		
34	Macro-module plug 5, 2-pole; 250V/4KV/3; 2,5MM2	31 12 091		
34	Macro-module plug 5, 3-pole; 250V/4KV/3; 2,5MM2	31 12 093		
34	Macro-module plug 5, 4-pole; 250V/4KV/3; 2,5MM2	31 12 094		
35	Cable bus; 5 X 0,34QMM	60003174		
36	Contactor B7:3H 1 N/C contact; 220-255V/50-60HZ	31 04 154		
36	Contactor B7:3H 1 N/C contact; 200V/50-60HZ	31 04 171		
37	Heater with fuse kit, 2.6kW; 1 X 220-240V	60004704		Option
37	Heater with fuse kit, 5.0kW; 3 X 380-420V	60004705		Option
37	Heater with fuse kit, 5.0kW; 3 X 230V	60004706		Option
37.1	O-ring; 46 X 6,0	27 07 085		
37.2	Hexagonal nut self securing; M5	21 05 302		
37.3	Bracket; 1,25 X 26,25 X 101,55	60004621		
38	Hexagonal nut; M5	21 01 203	3	
39	Protective film; 0,31 X 100 X 100	60004267		
40	Macro-module plug repair kit (3-pole; RAST 2,5)	30000198		3-pole
50	Wire set Control; 0,75QMM	60003172		
51	Wash pump cable; 3 X 1,5QMM; 850 LG	60003474		