

## THE PARTS ILLUSTRATIONS AND PARTS LIST

### CONTROL PANEL ASSY

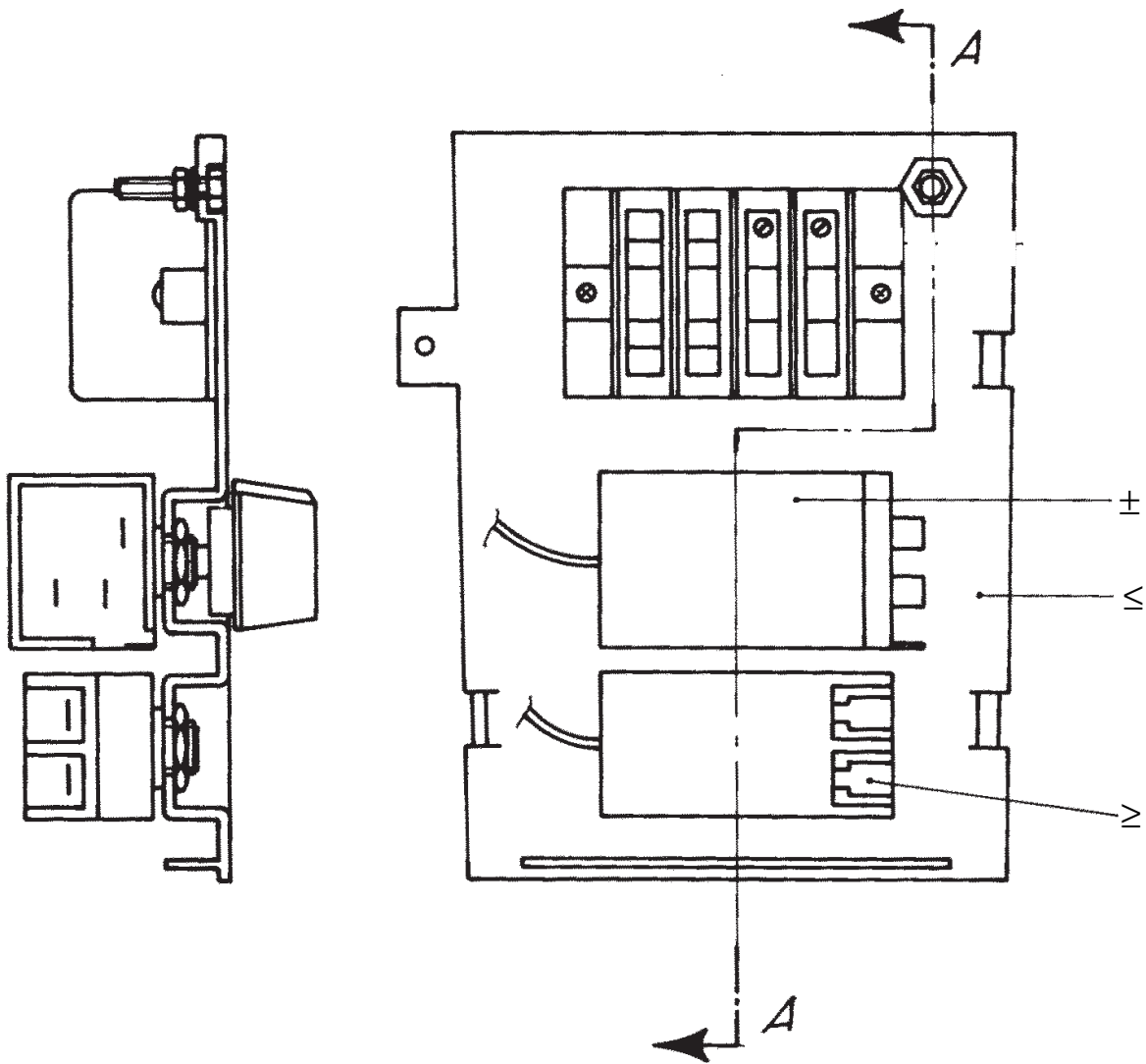

Pos.	Part. N.	Description
6	620264.10	Evaporator thermostat
7	660321.01	Panel
8	620263.00	Bin control

## FRONT - VIEW

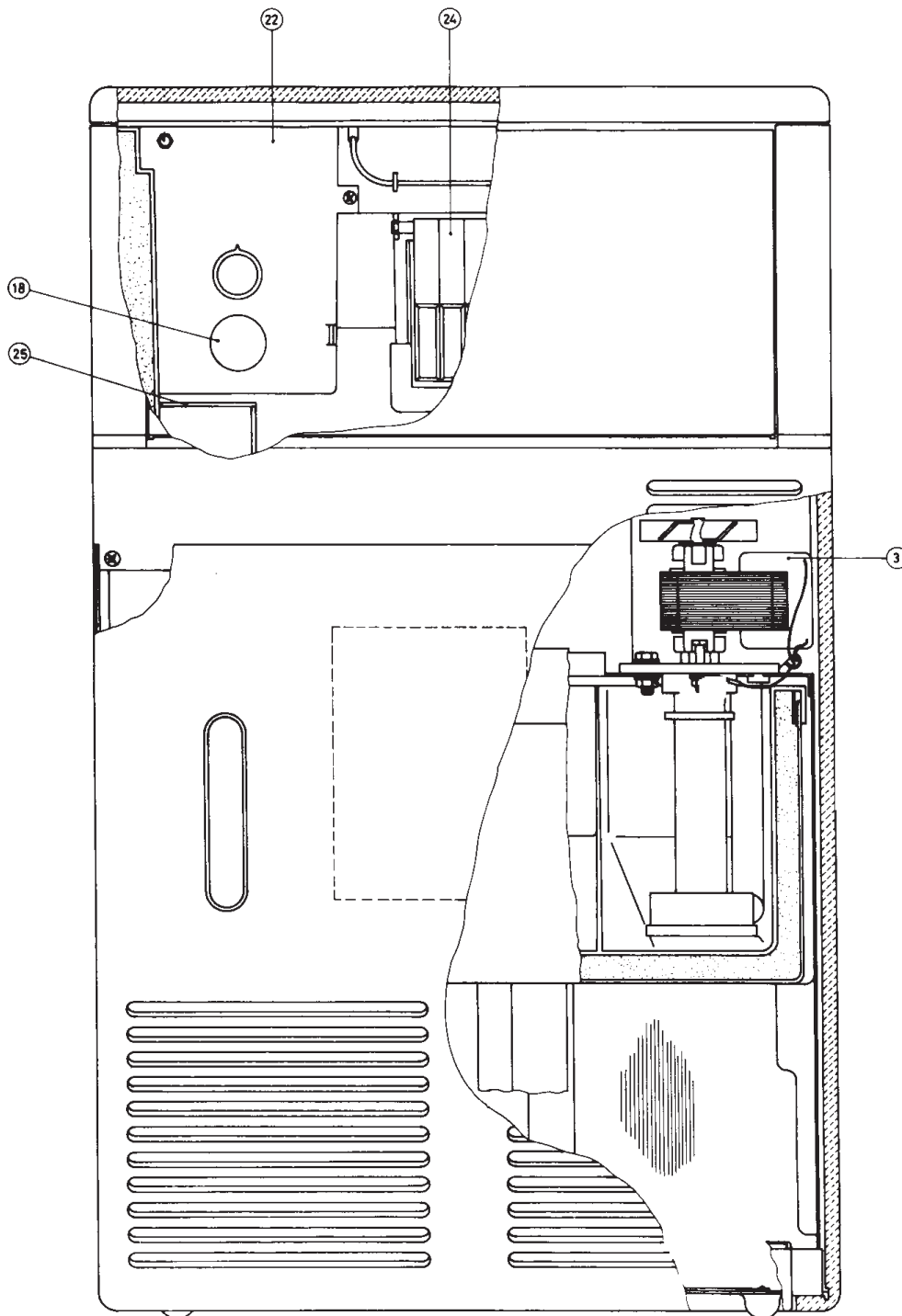

Pos.	Part. N.	Description
3	620433.00	Water pump assy
18	650330.00	Plug
22	660321.00	Control panel
24	784169.03	Curtain
25	660330.00	Funnel cover

**SIDE - VIEW**

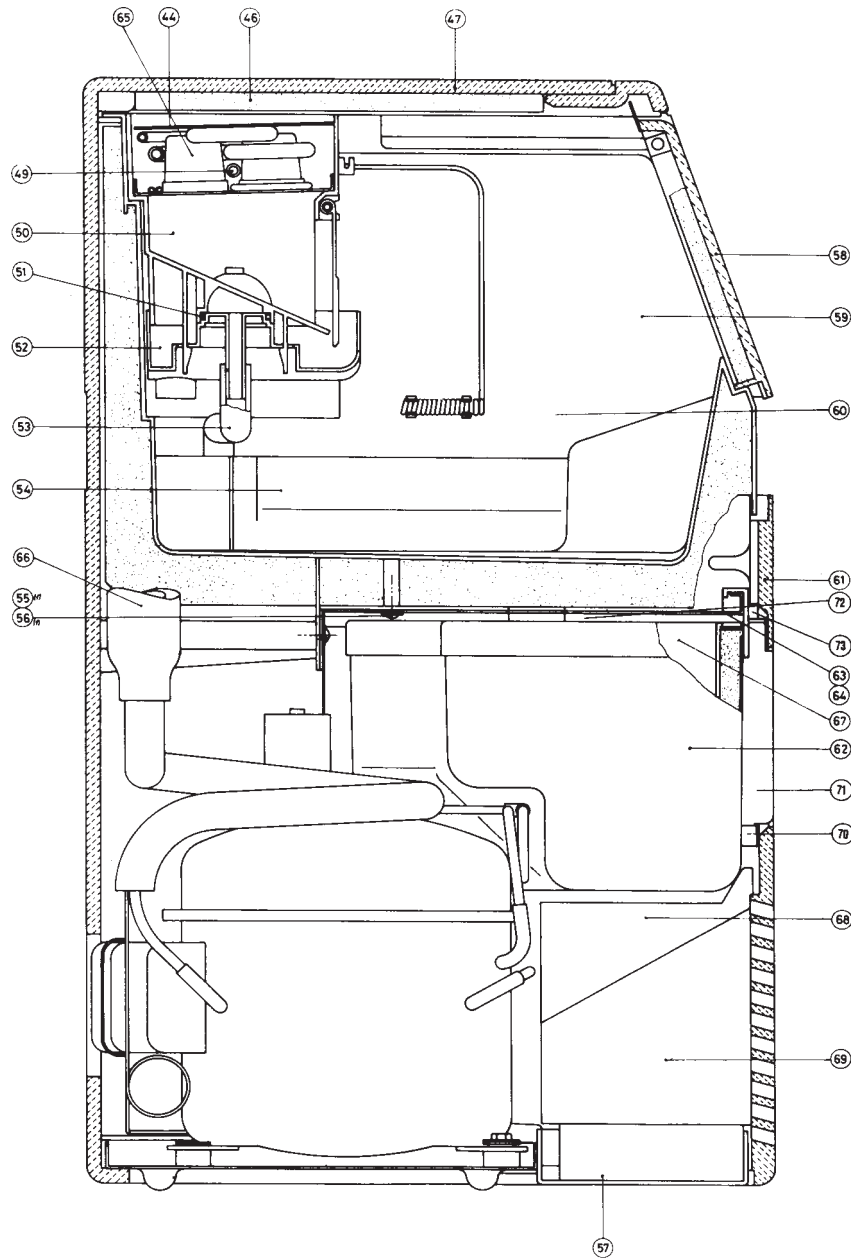

Pos.	Part. N.	Description	Pos.	Part. N.	Description
44	784378.02	Evaporator cover	61	781285.04	Front lower panel assy
46	650361.05	Insulation	62	793114.00	Water reservoir assy
47	660326.05	Cabinet assy	63	781335.00	Reservoir holder
49	660340.02	Evap. bulb holder	65	784234.00	Evaporator platen assy
	660386.00	Clip	66	784252.02	Suction accumulator
50	783130.00	Evap housing	67*	660359.00	Funnel insert
51	640093.00	Seal ring	68	660335.00	Upper separator
52	660320.00	Water spray tray	69	660343.00	Lower separator
53	610139.00	Plastic hose (pump to spray system)	70	660338.00	Rubber fitting
54	660336.00	Cover	71	660337.00	Sight glass
57	660325.00	Water drip tray	72*	783141.00	Reservoir cover
58	781284.03	Bin door assy		660424.00	Reservoir cover - Pump
59	782053.00	Ice storage bin	73	660341.00	Rubber plug
60	660339.00	Bulb holder			

\* Not shown

## COMPRESSOR & CONDENSING UNIT

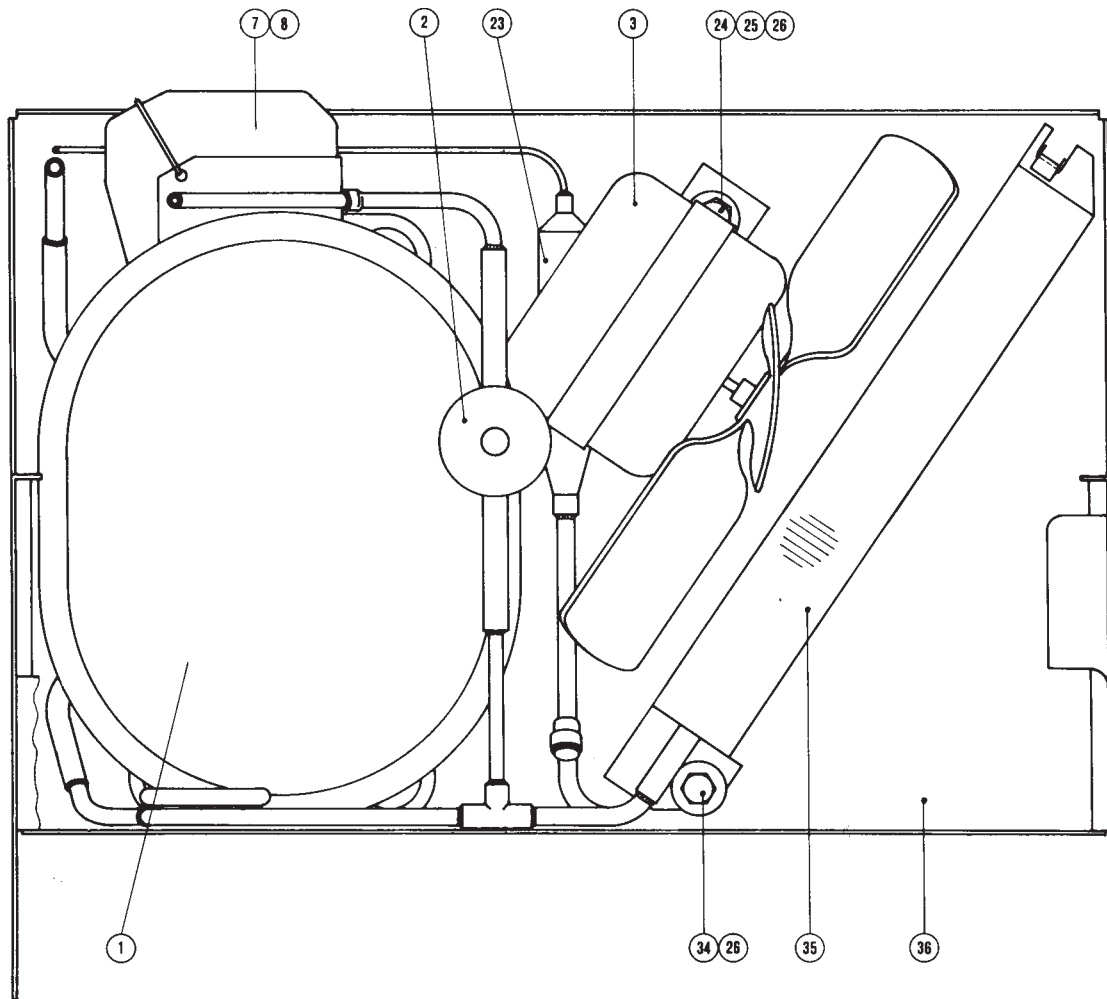

Pos.	Part. N.	Description
1	670097.08	Compressor cpl. Cubigel
2	620306.48	Hot gas valve coil
	620306.14	Hot gas valve body
3	620419.00	Fan motor only
7	620058.65	Protector for Cubigel

Pos.	Part. N.	Description
8	620057.35	Relay for Cubigel
23	630003.05	Dryer
35	620285.00	Condenser
36	781283.00	Chassis assy

## SD 10 - COMPRESSOR AND ELECTRIC COMPONENTS CHART

Model	Volts	Compr. Model	Compr. Cpl.	Compr. relay	Compr. protector	Start Capacitor
SD 10-2	220/60/1	U.H. AE Z4425Y	670066.08	620057.40	620058.74	620167.45
SD 10-6	220/50/1	Cubigel GL 80PB	670097.08	620057.35	620058.65	–

Model	Hot gas valve coil	Hot gas valve body	Water pump	Fan motor only
SD 10-2	620306.48	620306.14	620433.01	620419.00
SD 10-6	620306.48	620306.14	620433.00	620419.00