

SERIE 809

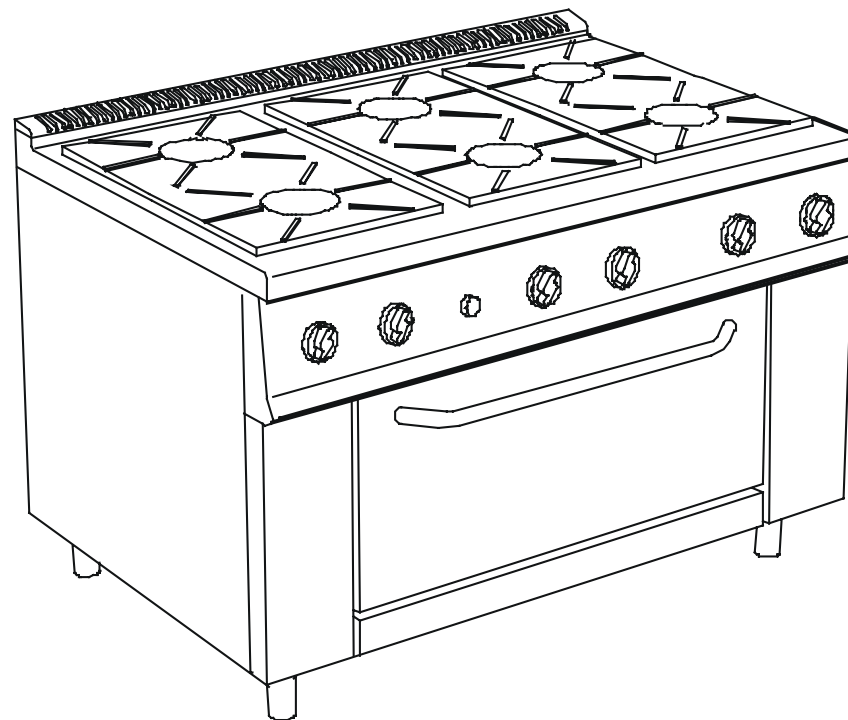

CUCINE A GAS CON PILOTA, SU FORNO MAXI
GAS RANGES WITH PILOT LIGHT, ON MAXI OVEN
GASHERDE MIT ZUENDFLAMMENBRENNER, MIT MAXIBACKOFEN
FORNEAUX GAZ AVEC PILOTE, AVEC FOUR MAXI

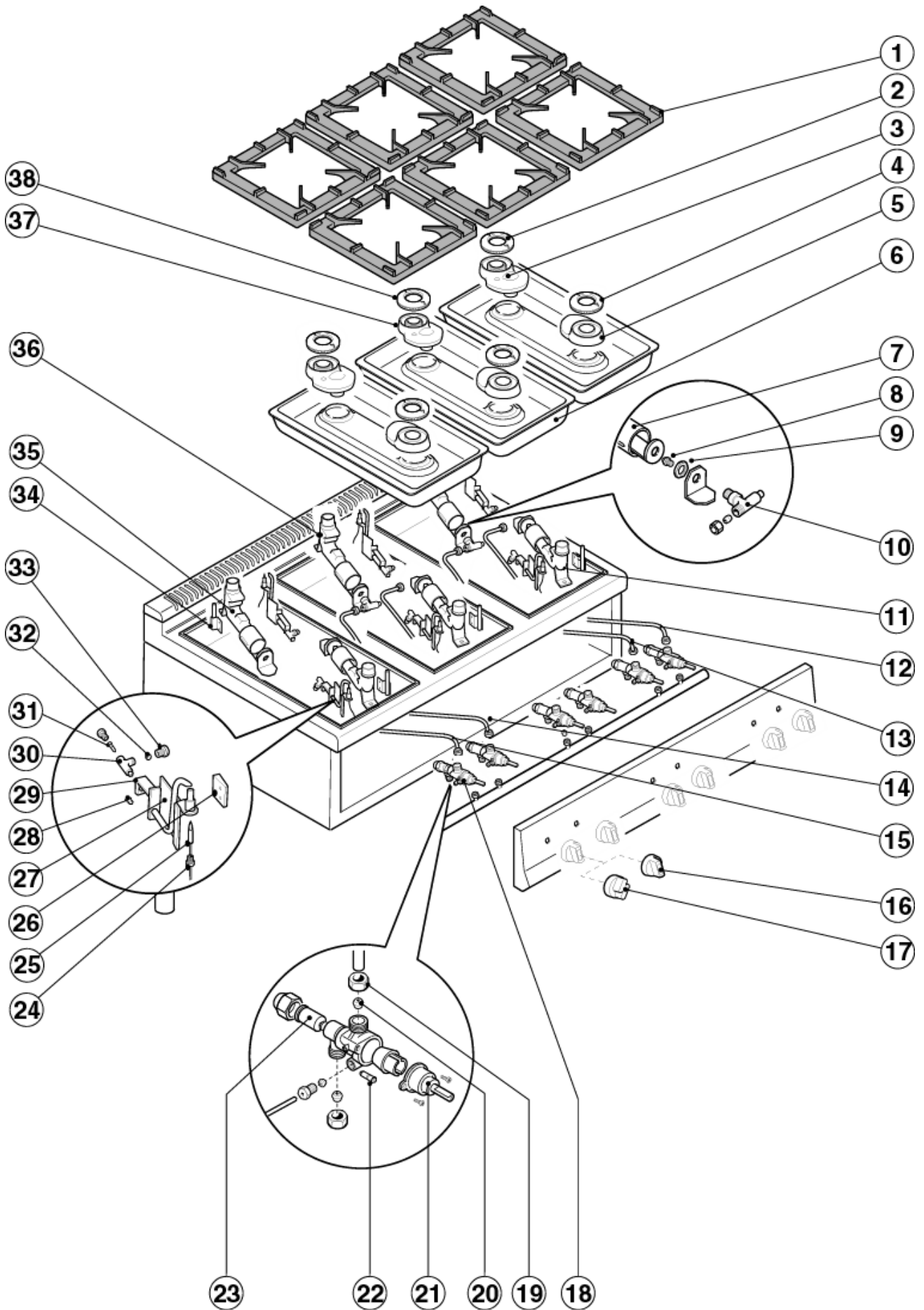

	COD.	REV.	DESCRIZIONE	DESCRIPTION	BESCHREIBUNG	DESCRIPTION
1	9204851		Griglia piano	Pan support	Auflagerost	Grille
2	0100253		Spartifiamma per bruciatore Ø 120	Flame-spreader for burner Ø 120	Brennerdeckel Ø 120	Couvercle pour brûleur Ø 120
3	0100224		Corpo bruciatore 7 kW	Body for 7 kW burner	Brennerkörper 7 kW	Corps pour brûleur 7 kW
4	0100252		Spartifiamma per bruciatore Ø 80	Flame-spreader for burner Ø 80	Brennerdeckel Ø 80	Couvercle pour brûleur Ø 80
5	0100225		Corpo bruciatore 3,5 kW	Body for 3,5 kW burner	Brennerkörper 3,5 kW	Corps pour brûleur 3,5 kW
6	9204782		Bacinella inox	Stainless steel top basin	Kochmulde aus Edelstahl	Plateau inox
7	0100264		Boccola aria primaria	Primary air bush	Luftschieber	Douille air primaire
8	Vedi tabella		Ugello	Nozzle	Düse	Gicleur
9	0100770		Dado M14x1 CH.18	Nut M14x1 CH.18	Mutter M14x1 CH.18	Ecrou M14x1 CH.18
10	0100767		Raccordo per ugello	Nozzle junction	Düsenverbindung	Raccord gicleur
11	0100301		Venturi per bruciatore 3.5 kW	Venturi tube for burner	Venturirohr für Brenner	Venturi pour brûleur
12	9201534		Conduittura gas anteriore bruciatore 3.5 kW	Front gas pipe 3.5 kW burner	Gasleitung vorne, 3.5 kW Brenner	Tube gaz arrière brûleur 5.5 kW
13	9201536		Conduittura gas anteriore bruciatore 5.5 kW	Front gas pipe 5.5 kW burner	Gasleitung vorne, 5.5 kW Brenner	Tube gaz avant brûleur 5.5 kW
14	9201535		Conduittura gas posteriore bruciatore 5.5 kW	Rear gas pipe 5.5 kW burner	Gasleitung hinten, 5.5 kW Brenner	Tube gaz arrière brûleur 5.5 kW
15	9201535		Conduittura gas posteriore bruciatore 7 kW	Rear gas pipe 7 kW burner	Gasleitung hinten, 7 kW Brenner	Tube gaz arrière brûleur 7 kW
16	0101954		Manopola con tappo	Knob with insert	Knebel Ø 65 für offene Kochstellenbrenner mit Pfropfen	Manette Ø 65 pour feux vifs avec insert
17	0101798		Manopola "S"	Knob "S"	knebel "S" für offene Kochstellenbrenner	Manette "S" pour feux vifs
18	0100731	C	Rubinetto per fuochi aperti	Cock for open burners	Gasarmatur für offene Kochstellenbrenner	Robinet pour brûleur ouverts
19	0100774		Raccordo per conduittura gas Ø 10	Gas pipe fitting Ø 10	Verschraubung für Gasleitung Ø 10	Raccord pour tube gaz Ø 10
20	0100775		Bicono per conduittura gas Ø 10	Gas pipe bicone Ø 10	Doppelkegelring für Gasleitung Ø 10	Bicône pour tube gaz Ø 10
21	0100773		Cappuccio per rubinetti 21S	Cover	Verschlußkappe	Couvercle
22	Vedi tabella		By-pass	By-pass	By-pass	By-pass
23	0100752		Magnete	Magneto	Magnet	Magnéto
24	0100817		Raccordo per termocoppia	Thermocouple connection	Verschraubung für Thermoelement	Raccord pour couple thermo-électrique
25a	0100808	C	Termocoppia L = 400 mm	Thermocouple L = 400 mm	Thermoelement 400 mm lang	Couple thermo-électrique L = 400 mm
25b	0100809	C	Termocoppia L = 850 mm	Thermocouple L = 850 mm	Thermoelement 850 mm lang	Couple thermo-électrique L = 850 mm
26	LC665-00		Distanziale per pilota bruciatore 3.5 kW	Spacer for 3.5 kW burner pilot	Abstandstück für 3.5 kW Pilotbrenner	Pièce entretoise pour pilote brûleur 3,5 kW
27	LC663-00		Assieme pilota	Pilot burner	Zündflammenbrenner	Brûleur pilote
28	0101151		Boccola regolazione aria	Air regulation bush	Luftregulierung Buechse	Douille regulation air
29	LC667-00		Squadretta fissaggio corpo pilota	Pilot fixing clamp	Pilotbefestigungsbuegel	Bride pilote
30	0101152	C	Corpo bruciatore con ugello	Body for burner with nozzle	Brennerkörper mit Düse	Corps pour brûleur avec gicleur
31	Vedi tabella		Ugello	Nozzle	Düse	Gicleur
32	0100745		Bicono pilota Ø 6	Bush for pilot Ø 6	Pilotdoppelkegelring Ø 6	Bicône brûleur d'allumage Ø 6
33	0100744		Dado pilota Ø 6	Nut for pilot Ø 6	Pilotmutter Ø 6	Ecrou brûleur d'allumage Ø 6
34	LC664-00		Assieme perno centraggio bruciatore	Burner centering dowel	Brennerzentrierstift	Pivot de centrage brûleur
35	0100303		Venturi per bruciatore 7 kW	Venturi tube for 7 kW burner	Venturirohr für 7 kW Brenner	Venturi pour 7 kW brûleur
36	0100302		Venturi per bruciatore 5.5 kW	Venturi tube for 5.5 kW burner	Venturirohr für 5.5 kW Brenner	Venturi pour 5.5 kW brûleur
37	0100223		Corpo bruciatore 5.5 kW	Body for 5.5 kW burner	Brennerkörper 5.5 kW	Corps pour brûleur 5.5 kW
38	0100251		Spartifiamma per bruciatore Ø 100	Flame-spreader for burner Ø 100	Brennerdeckel Ø 100	Couvercle pour brûleur Ø 100



TIPO DI BRUCIATORE	GAS	NAZIONI EN 203 - 1	PRESSIONE DI ALIMENTAZIONE	CODICE UGELLO Pos. 8	Ø 1/100	CODICE BY-PASS Pos. 22	Ø 1/100	CODICE UGELLO Pos. 31	Ø 1/100
C Qn = 3,5 kW	G 20	DK - FR - IT - ES	18 mbar	0100931	140	REGOLABILE	--	0101153	25
		DE - AT - FI - IE - PT - GB	20 mbar	0100931	140	REGOLABILE	--	0101153	25
	G 25	DE	20 mbar	0109072	155	REGOLABILE	--	0101153	25
		BE - FR - NL	25 mbar	0102009	146	REGOLABILE	--	0101153	25
	G 30	FR - IE - GB - ES - BE DK - IT - NL - PT - FI	28-30/37 mbar	0102010	90	REGOLABILE	--	0100829	20
		DE - AT	50 mbar	0100997	75 R	0102064	50	0100829	20
	G 110	ES - DK - IT - SE - CH	8 mbar	0102043	270	REGOLABILE	--	--	--
D Qn = 5,5 kW	G 20	DK - FR - IT - ES	18 mbar	0100932	175	REGOLABILE	--	0101153	25
		DE - AT - FI - IE - PT - GB	20 mbar	0100932	175	REGOLABILE	--	0101153	25
	G 25	DE	20 mbar	0102030	190	REGOLABILE	--	0101153	25
		BE - FR - NL	25 mbar	0102012	180	REGOLABILE	--	0101153	25
	G 30	FR - IE - GB - ES - BE DK - IT - NL - PT - FI	28-30/37 mbar	0100907	116	REGOLABILE	--	0100829	20
		DE - AT	50 mbar	0102013	95 R	0102063	60	0100829	20
	G 110	ES - DK - IT - SE - CH	8 mbar	0102044	350	REGOLABILE	--	--	--
E Qn = 7 kW	G 20	DK - FR - IT - ES	18 mbar	0101020	200	REGOLABILE	--	0101153	25
		DE - AT - FI - IE - PT - GB	20 mbar	0101020	200	REGOLABILE	--	0101153	25
	G 25	DE	20 mbar	0102014	220	REGOLABILE	--	0101153	25
		BE - FR - NL	25 mbar	0102015	207	REGOLABILE	--	0101153	25
	G 30	FR - IE - GB - ES - BE DK - IT - NL - PT - FI	28-30/37 mbar	0101019	130	REGOLABILE	--	0100829	20
		DE - AT	50 mbar	0102016	105 R	0102067	70	0100829	20
	G 110	ES - DK - IT - SE - CH	8 mbar	0102045	420	REGOLABILE	--	--	--



Mod. : CG86HPS

	XES30803/G	PAG. 6/9
---	------------	----------

da matricola - from serial Nr.	a matricola - to serial Nr.
-----------------------------------	--------------------------------

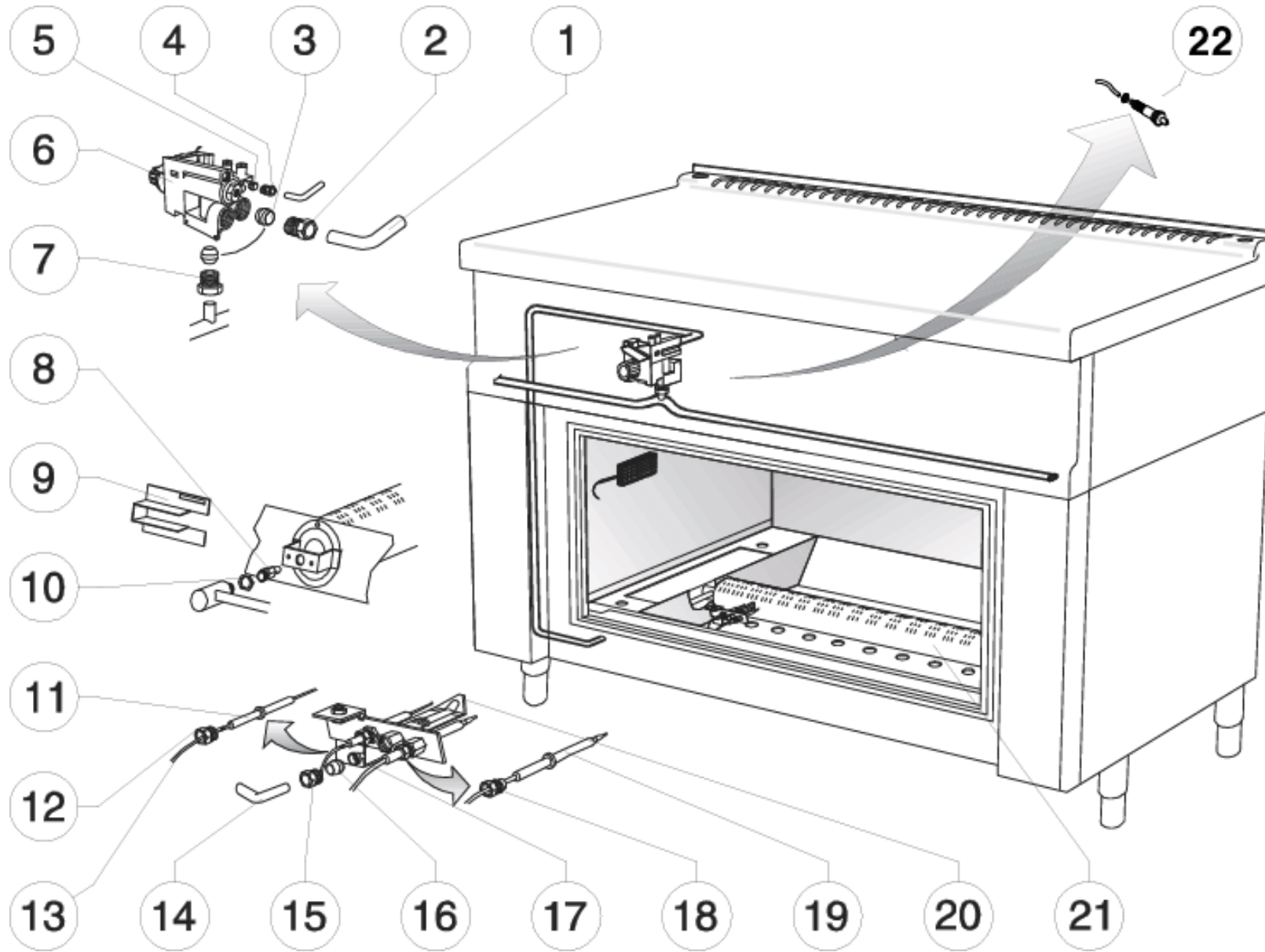

	COD.	REV.	DESCRIZIONE	DESCRIPTION	BESCHREIBUNG	DESCRIPTION
1	LB542-00		Condutt. valvola-forno NS70E	Tube gas valve-700S. ovens	Gasventilleitung S.700E	Conduite sopape four S. 700E
2	0100841		Raccordo valvola forno Eurosit	Connection for Eurosit valve	Ventilverschraubung Eurosit	Raccord pour soupape Eurosit
3	0100842		Bicono per conduttura gas Ø 12	Gas pipe bush Ø 12	Doppelkegelring für Gasleitung Ø 12	Bicône pour tube gaz Ø 12
4	0100744		Raccordo per conduttura gas Ø 6	Gas pipe fitting Ø 6	Verschraubung für Gasleitung Ø 6	Raccord pour tube gaz Ø 6
5	0100745		Bicono per conduttura gas Ø 6	Gas pipe bush Ø 6	Doppelkegelring für Gasleitung Ø 6	Bicône pour tube gaz Ø 6
6	KVL0002	C	Valvola gas per il forno completa di accessori	Gas valve for oven with accessories	Gasarmatur für Backofen mit Zubehöre	Soupape gaz pour le four avec accessoires
6a	0100879		Valvola gas per il forno	Gas valve for oven	Gasarmatur für Backofen	Soupape gaz pour le four
7	LB555-00		Racc. entr. valv. forno Eurosit	Inlet connect.-Eurosit valve	Ventileingangsversch. Eurosit	Racc. entr. soupape four Eurosit
8	vedi tab.		Ugello	Nozzle	Düse	Injecteur
9	9203235		Boccola aria per bruciatore principale forno	Air bush for oven main burner	Luftschieber für Backofenbrenner	Douille air pour brûleur principal four
10	0100770		Dado M14X1 CH. 18 (3638)	Nut - M14X1 CH. 18 (3638)	Mutter M14X1 CH. 18 (3638)	Ecrou M14X1 CH. 18 (3638)
11	0100831	C	Candela d'accensione	Igniter plug	Zündkerze	Bougie d'allumage
12	0100807	C	Raccordo per candela d'accensione	Igniter plug connection	Verschraubung für Zündkerze	Raccord pour bougie d'allumage
13	0101659	C	Cavetto d'accensione	Igniter cable	Zündkabel (für Zündkerze)	Fil d'allumage
14	LB543-00		Conduttura gas per bruciatore pilota del forno	Gas pipe for oven pilot burner	Gasleitung für Backofen-Zündflammenbrenner	Tube gaz pour brûleur pilote du four
15	0100744		Raccordo per conduttura gas Ø 6	Gas pipe fitting Ø 6	Verschraubung für Gasleitung Ø 6	Raccord pour tube gaz Ø 6
16	0100743		Bicono per conduttura gas	Gas pipe bush	Doppelkegelring für Gasleitung	Bicône pour tube gaz
17	vedi tab.		Ugello pilota	Pilot injector	Zündflammenbrennerdüse	Injecteur pilote
18	0100817	C	Raccordo per termocoppia	Thermocouple connection	Verschraubung für Thermoelement	Raccord pour couple thermo-électrique
19	0100818	C	Termocoppia L=1500 mm	Thermocouple L =1500 mm	Thermoelement 1500 mm lang	Thermocouple L = 1500 mm
20	0101047	C	Bruciatore pilota	Pilot burner	Zündflammenbrenner	Brûleur pilote
21	0101051		Bruciatore	Burner	Brenner	Brûleur
22	0100893	C	Accensione piezo	Piezoelectric ignition	Piezozünder	Allumage piézoélectrique

TIPO DI BRUCIATORE Pos. 21	GAS	NAZIONI EN 203 - 1	PRESSIONE DI ALIMENTAZIONE	CODICE UGELLO Pos. 8	Ø 1/100	CODICE UGELLO Pos. 17	Ø 1/100
Qn = 8 kW	G 20	T-DK-ES-FI-IE-IT-PT-GB-SE-CH	20 mbar	0102017	220	0101048	27
		DE-BE-FR	20/25 mbar	0102017	220		
	G 25	NL	25 mbar	0102017	220	0101049	22
		DE	20 mbar	0102018	240		
	G 30 G 31	BE-DK-ES-FI-FR-IE IT-NL-PT-GB-SE	28-30/37 mbar	0102024	140	0101049	22
		DE-AT-CH	50 mbar	0102019	120		



COD. XES308023/G

PAG. 7/9

Mod. : CG86HPS

	XES30803/G	PAG. 8/9
da matricola - from serial Nr.	a matricola - to serial Nr.	

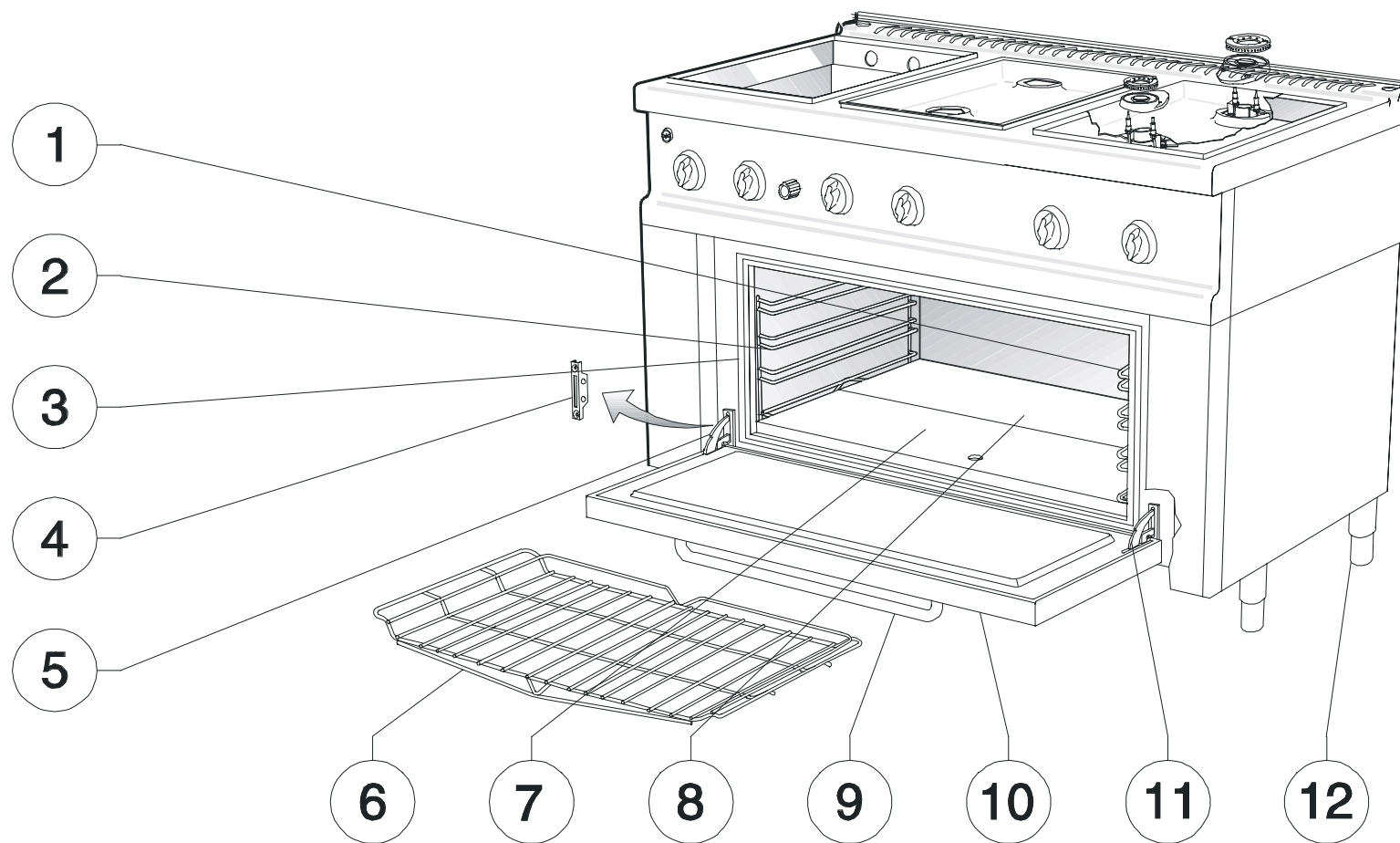

	COD.	REV.	DESCRIZIONE	DESCRIPTION	BESCHREIBUNG	DESCRIPTION
1	LB534-00	01	Supporto dx griglia	Rh tray slides	Rostträger dx	Support grille dx
2	LB535-00	01	Supporto sx griglia	Lh tray slides	Rostträger sx	Support grille sx
3	LB848-00		C Guarnizione porta forno	Oven door gasket	Ofentürdichtung	Garniture porte four
4	0100343		C Fermo per cerniera SC45 DX/SX	Hinge cover SC 45	Scharnierhalter SC 45 DX/SX	Arrêt p. charnière SC 45 DX/SX
5	0100342		C Cerniera compl. per SC45 SX	LH Hinge - SC 45	Komplettes Scharnier SC 45 SX	Charniere complete SC 45 SX
6	LB531-00		Griglia GN 2/1	GN 2/1 chrome wire grid	Rost GN 2/1	Grille GN 2/1
7	LB539-00		Suola anteriore	Oven (front) base plate	Vorderer Ofenboden	Sole ant.
8	LB540-00		Suola posteriore	Oven (rear) base plate	Hinterer Ofenboden	Sole post.
9	LB965-00		Maniglia porta	Oven door handle	Türgriff	Poignée porte
10	LB605-00		Ass. porta forno	Oven door	Backofentür	Porte four
11	0100341		C Cerniera compl. per SC45 DX	RH Hinge - SC 45	Komplettes Scharnier SC 45 DX	Charniere complete SC 45 DX
12	0100323		Ass. piedino da 1"3/4 H=165	Foot 1" 3/4 H = 165	Fuss 1" 3/4 H= 165	Pied 1" 3/4 H = 165