

SERIE 700

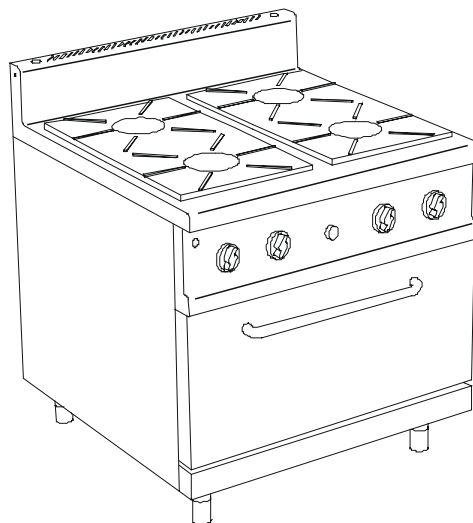

CUCINA GAS 4 FUOCHI, SU FORNO GAS

2 bruciatori da 3.5 Kw + 2 bruciatori da 5.5 Kw + 1 bruciatore forno da 8 Kw

GAS RANGES 4 BURNERS ON GAS OVEN

2 burners 3.5 Kw + 2 burners 5.5 kW + 1 oven burner 8 Kw

GASHERDE 4 FLAMMEN, GAS-BACKOFEN

2 x 3.5 kW-Brenner + 2 x 5.5 kW-Brenner + 1 Backofen Brenner 8 kW

FORNEAUX GAZ 4 FEUX, FOUR A GAZ

2 brûleurs 3.5 Kw + 2 brûleurs 5.5 Kw + 1 brûleur four 8 Kw

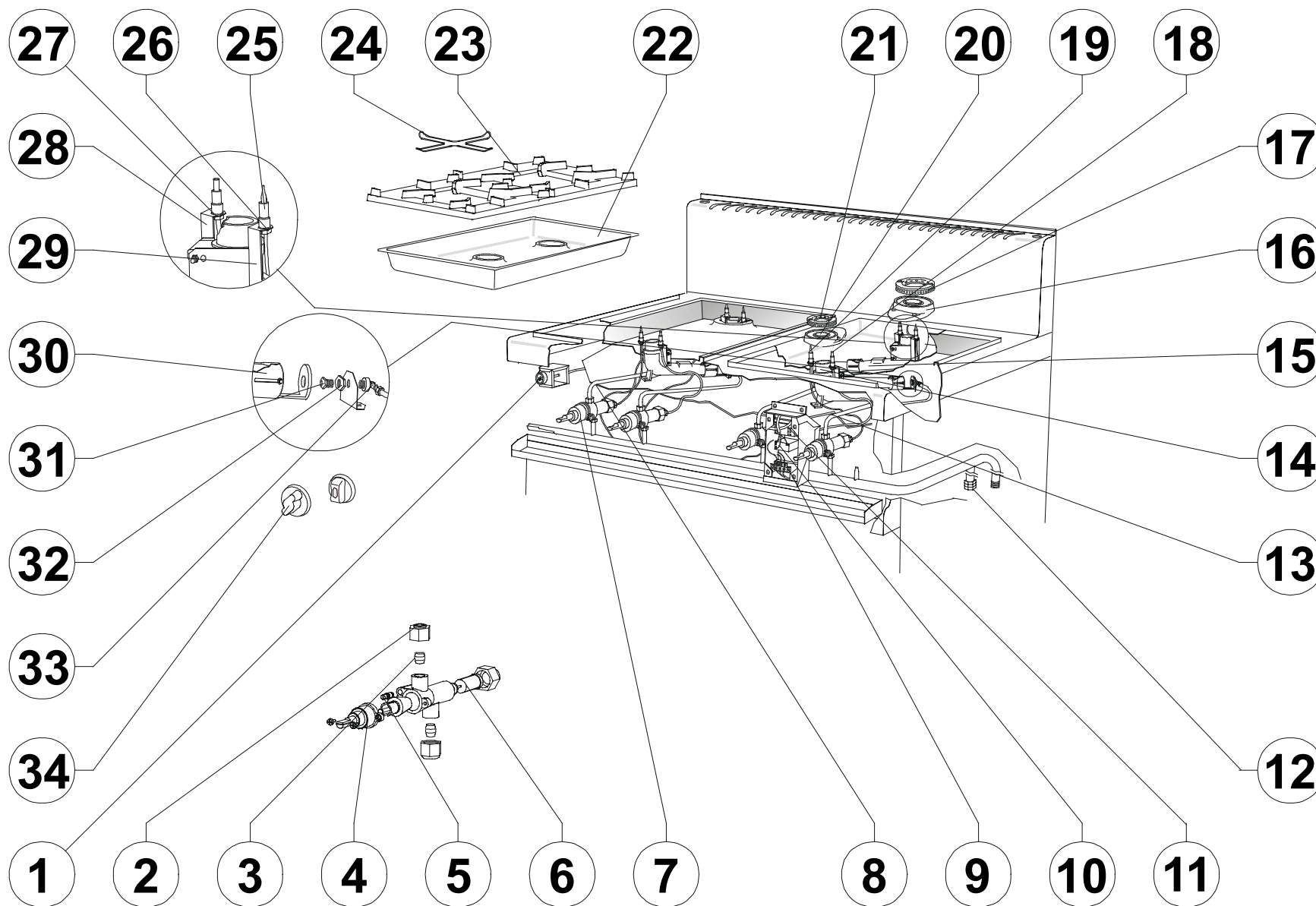

	COD.	REV.	DESCRIZIONE	DESCRIPTION	BESCHREIBUNG	DESCRIPTION
1	0101188		C Pulsante per accensione elettrica	Electric ignition key	Druckknopf für el. Zündung	Bouton d'allumage électrique
2	0100774		Raccordo per condotta gas Ø10	Gas pipe fitting Ø10	Verschraubung für Gasleitung Ø10	Raccord pour tube gaz Ø10
3	0100775		Bicono per condotta gas Ø10	Gas pipe bicone Ø10	Doppelkegelring für Gasleitung Ø10	Bicône pour tube gaz Ø10
4	0100753		Cappuccio per rubinetto	Cap for gas cock	Kappe für Gashahn	Copuchon pour robinet gaz
5	vedi tabella		By-pass	By-pass	By-pass	By-pass
6	0100752		Magnete	Magneto	Magnet	Magnéto
7	0100730		C Rubinetto per fuochi aperti	Cock for open burners	Gasarmatur für offene Kochstellenbrenner	Robinet pour brûleur ouverts
8	LB547-00		Conduttura gas posteriore, bruciatore D, per versione 70	Rear gas pipe burner D, version 70	Gasleitung hinten, D-Brenner, Version 70	Tube gaz arrière brûleur D, version 70
8a	LC671-00		Conduttura bruciatore 5.5 Kw posteriore, per versione 72	5.5 Kw rear gas pipe burner, version 72	5.5 Kw Gasleitung hinten, Brenner, Version 72	5.5 Kw tube gaz arrière brûleur, version 72
9	0101253		Morsettiere	Junction block	Klemmkasten	Serre-fils
10	0101193		C Trasformatore d'accensione per 2 fuochi	Ignition transformer for 2 burners	Zündtransformator für 2 brenner	Transformateur d'allumage pour 2 brûleur
12	0101275		Raccordo filettato antistr. 107Z/11	Threaded connection	Verschraubung	Raccord fileté
11	0101194		C Trasformatore d'accensione per 4 fuochi	Ignition transformer for 4 burners	Zündtransformator für 4 brenner	Transformateur d'allumage pour 4 brûleur
13	LB545-00		Conduttura gas posteriore, bruciatore C, per versione 70	Rear gas pipe burner C, version 70	Gasleitung hinten, C-Brenner, Version 70	Tube gaz arrière brûleur C, version 70
13a	LC670-00		Conduttura bruciatore 3.5 Kw posteriore, per versione 72	3.5 Kw rear gas pipe burner, version 72	3.5 Kw Gasleitung hinten, Brenner, Version 72	3.5 Kw tube gaz arrière brûleur, version 72
14	0100301		Venturi per bruciatore 3.5 kW lav. per boccola	Venturi tube for burner 3.5 kW for bush	Venturirohr für Brenner 3.5 kW für Luftschieber	Venturi pour brûleur 3.5 kW pour douille
15	0100302		Venturi per bruciatore 5.5 kW lav. per boccola	Venturi tube for burner 5.5 kW for bush	Venturirohr für Brenner 5.5 kW für Luftschieber	Venturi pour brûleur 5.5 kW pour douille
16	0100299		Corpo per bruciatore 5.5 kW con boccola	Body for burner 5.5 kW with bush	Brennerkörper 5.5 kW mit Luftschieber	Corps pour brûleur 5.5 kW avec douille
17	0100251		Spartifiamma per bruciatore D	Flame spreader r for burner D	Brennerdeckel D	Couvercle pour brûleur D
18	9300542		C Candela e cavetto d'accensione L=550 mm	Igniter plug and cable L=550 mm	Zündkerze mit Zündkabel 550 mm lang	Bougie et fil d'allumage L=550 mm
19	0100808		C Termocoppia L=400 mm	Thermocouple L=400 mm	Thermoelement 400 mm lang	Couple thermo-électrique L=400 mm
20	0100298		Corpo per bruciatore 3.5 kW con boccola	Body for burner 3.5 kW with bush	Brennerkörper 3.5 kW mit Luftschieber	Corps pour brûleur 3.5 kW avec douille
21	0100252		Spartifiamma per bruciatore C	Flame spreader for burner C	Brennerdeckel C	Couvercle pour brûleur C
22	LB847-00	01	Bacinella piano in acciaio inossidabile	Stainless steel top basin	Kochmulde aus Edelstahl	Plateau Inox
23	0101808		Griglia piano smaltata	Enamelled pan support	Auflagerost emailiert	Grille émaillée
23a	0101807		Griglia piano vetrificata	Glazed pan support	Auflagerost verglast	Grille vitrifié
24	0101080		Griglia riduzione N.S. Snack	Pan support reduction piece	Reduzierring Snack 650	Grille de réduction Snack
25	0100809		C Termocoppia L=850 mm	Thermocouple L=850 mm	Thermoelement 850 mm lang	Thermocouple L=850 mm
26	0100817		Raccordo per termocoppia	Thermocouple connection	Verschraubung für Thermoelement	Raccord pour couple thermo-électrique
27	0100620		Raccordo per candela d'accensione	Igniter plug connection	Verschraubung für Zündkerze	Raccord pour bougie d'allumage
28	LB839-00		Supporto per candela d'accensione	Support for igniter plug	Zündkerzhalter	Support pour bougie d'allumage
29	LB838-00		Supporto per termocoppia	Support for thermocouple	Halterung für Thermoelement	Support couple thermo-électrique
30	0100264		Boccola aria primaria	Primary air bush	Luftschieber	Douille air primaire
31	vedi tabella		Ugello	Nozzle	Düse	Gicleur
32	0100770		Dado	Nut	Mutter	Ecrou
33	0100767		Raccordo per ugello	Nozzle junction	Düsenverbindung	Raccord gicleur
34	0101786		Manopola "S" per fuochi aperti	Knob "S" for open burners	Knebel "S" für offene Kochstellenbrenner	Manette "S" pour feux vifs
34a	0101953		Manopola Ø65 per fuochi aperti completa di tappo	Knob Ø65 for open burners with insert	Knebel Ø65 für offene Kochstellenbrenner mit Pfropfen	Manette Ø65 pour feux vifs avec insert

TIPO DI BRUCIATORE	GAS	NAZIONI CE EN 203 - 1	PRESSIONE DI ALIMENTAZIONE	COD. UGELLO Pos. 31	Ø 1/100	COD. BY-PASS Pos. 5	Ø 1/100
C Qn = 3,5 kW	G 20	AT-DK-ES-FI-IE-IT-PT-GB-SE-CH	20 mbar	0100905	145	0102060	100
		DE-BE-FR	20/25 mbar	0100905	145	0102060	100
	G 25	NL	25 mbar	0102009	146	0102062	105
		DE	20 mbar	0109072	155	0102061	110
	G 30 G 31	BE-DK-ES-FI-FR-IE IT-NL-PT-GB-SE	28-30/37 mbar	0102010	90	0102063	60
		DE-AT-CH	50 mbar	0102011	80 R	0102064	50
D Qn = 5,5 kW	G 20	AT-DK-ES-FI-IE-IT-PT-GB-SE-CH	20 mbar	0102012	180	0102061	110
		DE-BE-FR	20/25 mbar	0102012	180	0102061	110
	G 25	NL	25 mbar	0100906	185	0102066	115
		DE	20 mbar	0101020	200	0102065	120
	G 30 G 31	BE-DK-ES-FI-FR-IE IT-NL-PT-GB-SE	28-30/37 mbar	0100907	116	0102067	70
		DE-AT-CH	50 mbar	0102013	95 R	0102063	60



COD. XES30701/G

PAG. 5/9

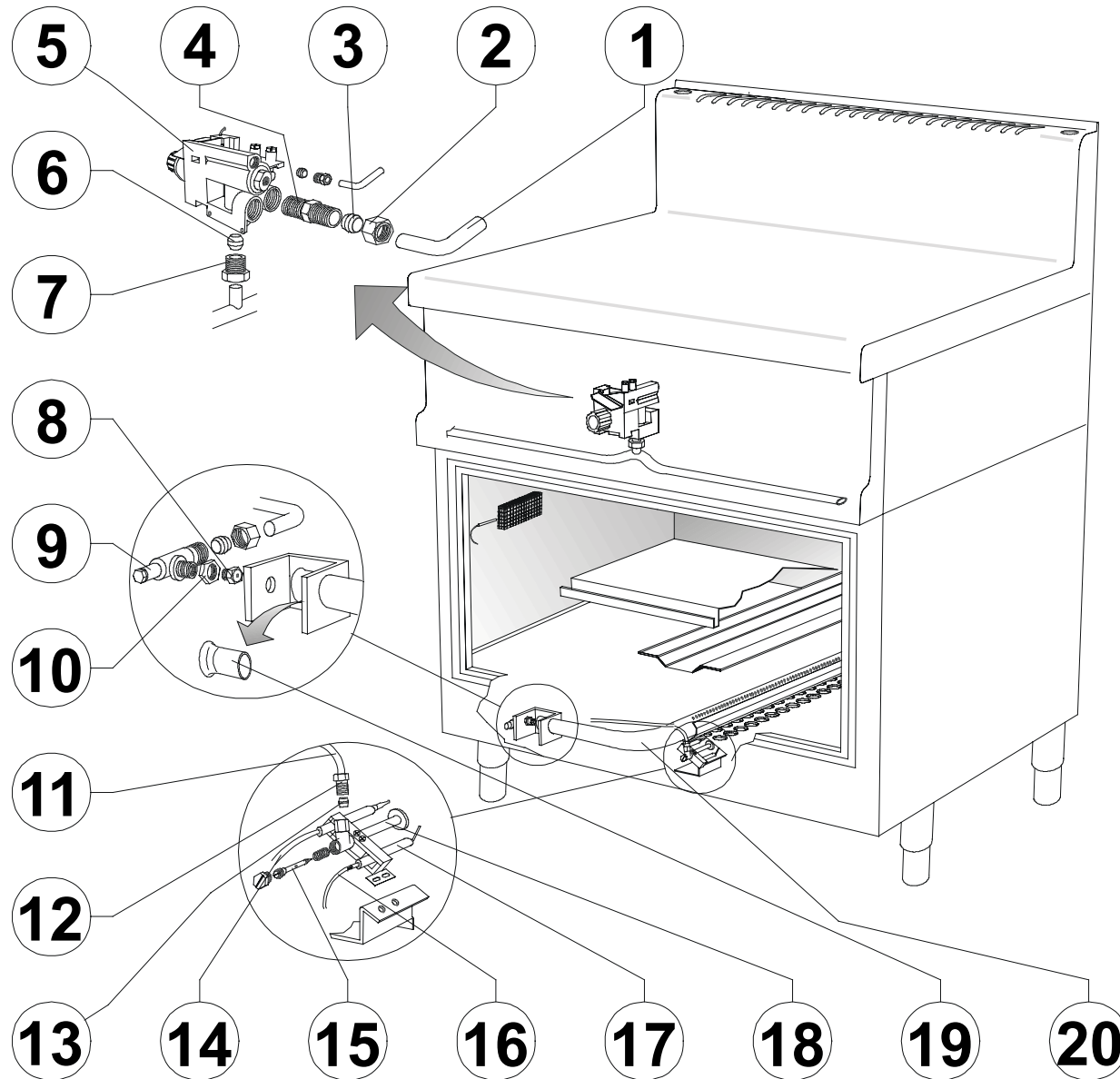

	COD.	REV.	DESCRIZIONE	DESCRIPTION	BESCHREIBUNG	DESCRIPTION
1	LB573-00		Conduttura valvola-forno NS70E	Pipe gas valve-700S. ovens	Gasventilleitung S.700E	Conduite sopape four S. 700E
1a	LB618-00		Conduttura gas per bruciatore forno ST 766 LE	Gas pipe for oven burner ST 766 LE	Gasleitung für Backofen-brenner ST 766 LE	Tube gaz pour brûleur du four ST 766 LE
2	0100774		Raccordo per conduttura gas Ø10	Gas pipe fitting Ø10	Verschraubung für Gasleitung Ø10	Raccord pour tube gaz Ø10
3	0100775		Bicono per conduttura gas Ø10	Gas pipe bicone Ø10	Doppelkegelring für Gasleitung Ø10	Bicône pour tube gaz Ø10
4	LB554-00		Raccordo valvola forno Eurosit	Connection for Eurosit valve	Ventilverschraubung Eurosit	Raccord pour soupape Eurosit
5	KVL0001	C	Valvola gas per il forno completa di accessori	Gas valve for oven with accessories	Gasarmatur für Backofen mit Zubehöre	Soupape gaz pour le four avec accessoires
5a	0100873		Valvola gas per il forno	Gas valve for oven	Gasarmatur für Backofen	Soupape gaz pour le four
6	0100842		Bicono per conduttura gas Ø12	Gas pipe bicone Ø12	Doppelkegelring für Gasleitung Ø12	Bicône pour tube gaz Ø12
7	LB555-00		Raccordo entrata valvola forno Eurosit	Inlet connect.-Eurosit valve	Ventileingangsversch. Eurosit	Racc. entr. soupape four Eurosit
8	vedi tab.		Ugello	Nozzle	Düse	Injecteur
9	0100767		Raccordo per ugello D. 10 (311154)	Nozzle junction - D.10 (311154)	Duensenverbindung D. 10 (311154)	Raccord gicleur D. 10 (311154)
10	0100770		Dado M14X1 CH. 18 (3638)	Nut - M14X1 CH. 18 (3638)	Mutter M14X1 CH. 18 (3638)	Ecrou M14X1 CH. 18 (3638)
11	LB574-00		Conduttura gas per bruciatore pilota del forno	Gas pipe for oven pilot burner	Gasleitung für Backofen-Zündflammenbrenner	Tube gaz pour brûleur pilote du four
11a	LB619-00		Conduttura gas per pilota forno ST 766 LE	Gas pipe for oven pilot ST 766 LE	Gasleitung für Backofen-ZündflammenbrennerST766LE	Tube gaz pour pilote du four ST 766 LE
12	0100777		Raccordo per conduttura gas Ø4	Gas pipe fitting Ø4	Verschraubung für Gasleitung Ø4	Raccord pour tube gaz Ø4
13	0100778		Bicono per conduttura gas Ø4	Gas pipe bicone Ø4	Doppelkegelring für Gasleitung Ø4	Bicône pour tube gaz Ø4
14	0100818	C	Termocoppia L=1500 mm	Thermocouple L=1500 mm	Thermoelement 1500 mm lang	Thermocouple L=1500 mm
15	vedi tab.		Ugello pilota	Pilot injector	Zündflammenbrennerdüse	Injecteur pilote
16	0101632	C	Cavetto d'accensione	Igniter cable	Zündcabel (für Zündkerze)	Fil d'allumage
17	0100832	C	Candela d'accensione	Igniter plug	Zündkerze	Bougie d'allumage
18	0100824	C	Bruciatore pilota	Pilot burner	Zündflammenbrenner	Brûleur pilote
19	0100262		Boccola aria per bruciatore principale forno	Air bush for oven main burner	Luftschieber für Backofenbrenner	Douille air pour brûleur principal four
20	0100277		Bruciatore	Burner	Brenner	Brûleur

BRUCIATORE Pos. 20	GAS	NAZIONI EN 203 - 1	PRESSIONE DI ALIMENTAZIONE	COD. UGELLO Pos. 8	Ø 1/100	COD. UGELLO Pos. 15	Ø 1/100
Qn = 8 kW	G 20	AT-DK-ES-FI-IE-IT-PT-GB-SE-CH	20 mbar	0101012	215	0100823	40
		DE-BE-FR	20/25 mbar	0101012	215		
	G 25	NL	25 mbar	0102014	220		
		DE	20 mbar	0101036	235		
	G 30 G 31	BE-DK-ES-FI-FR-IE IT-NL-PT-GB-SE	28-30/37 mbar	0100931	140	0100829	20
		DE-AT-CH	50 mbar	0101034	120		



COD. XES30701/G

PAG. 7/9

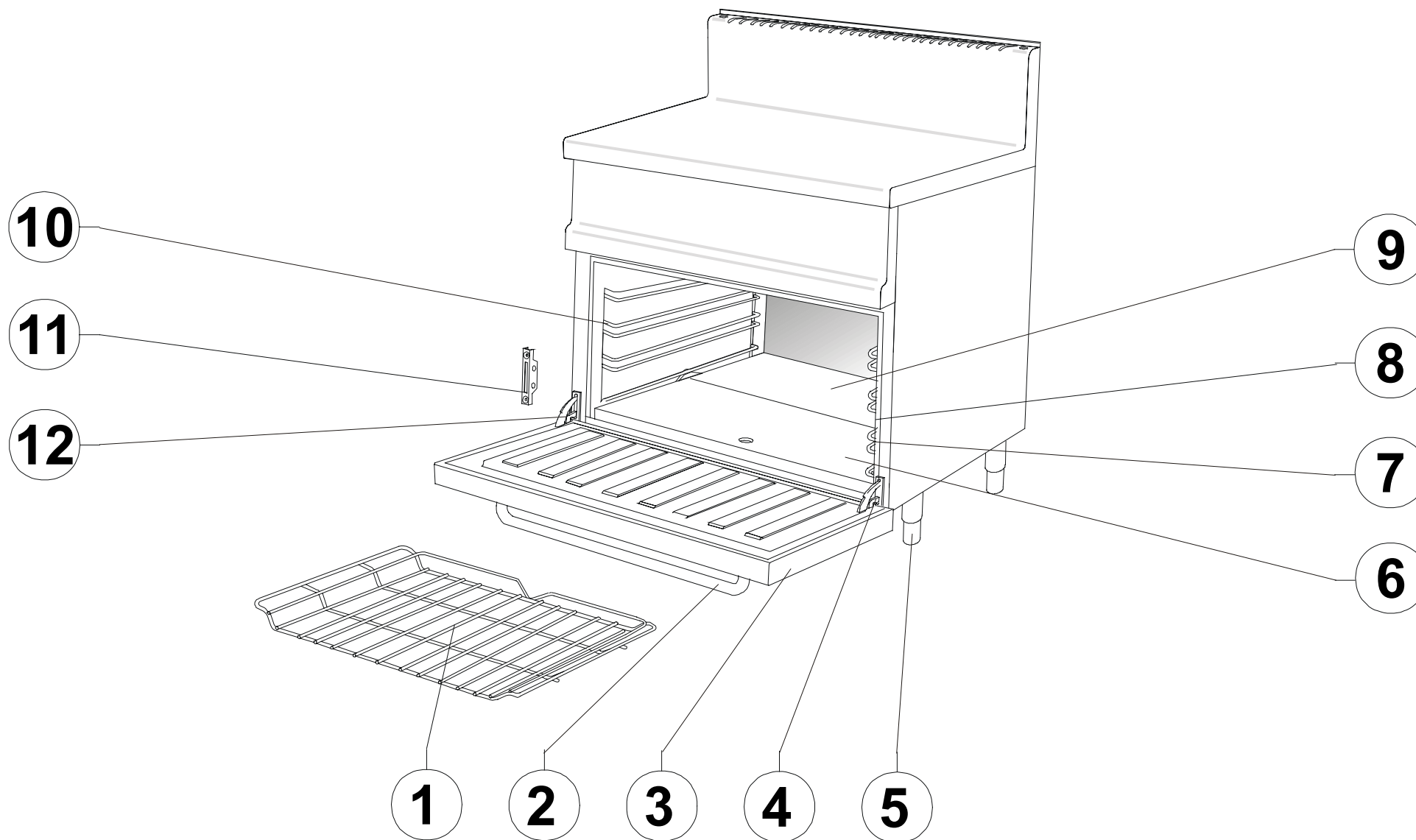

	COD.	REV.	DESCRIZIONE	DESCRIPTION	BESCHREIBUNG	DESCRIPTION
1	LB530-00	02	Griglia GN 2/1	GN 2/1 chrome wire grid	Rost GN 2/1	Grille GN 2/1
2	LB536-00		Maniglia porta	Oven door handle	Türgriff	Poignée porte
2a	LB965-00		Assieme maniglia porta forno cucine versione "1"-"2"	Oven door handle version 1-2	Backofentürgriff Ausführung 1 – 2	Poignée porte four version 1-2
2b	LC740-00		Assieme maniglia porta forno cucine versione "3"	Oven door handle version 3	Backofentürgriff Ausführung 3	Poignée porte four version 3
3	LB956-00		Assieme porta forno	Oven door	Backofentür	Porte four
4	0100346	C	Cerniera completa per SC45 DX	Rh hinge - SC 45	Komplettes Schamier SC 45 Rechte	Charniere complete SC 45 droite
5	0100323	02	Assieme piedino da 1"3/4 H=165	Foot 1" 3/4 H = 165	Fuss 1" 3/4 H= 165	Pied 1" 3/4 H = 165
6	LB537-00		Suola anteriore	Oven (front) base plate	Vorderer Ofenboden	Sole ant.
7	LB532-00		Supporto dx griglia	Rh tray slides	Rostträger Rechte	Support grille droite
8	LB848-00	C	Guarnizione porta forno	Oven door gasket	Ofentürdichtung	Garniture porte four
9	LB538-00		Suola posteriore	Oven (rear) base plate	Hinterer Ofenboden	Sole post.
10	LB533-00		Supporto sx griglia	Lh tray slides	Rostträger Linke	Support grille gauche
11	0100343	C	Fermo per cerniera SC45 DX/SX	Hinge cover SC 45	Schamierhalter SC 45 Rechte/Linke	Arrêt pour charnière SC 45 droite/gauche
12	0100345	C	Cerniera completa per SC45 SX	Lh hinge - SC 45	Komplettes Schamier SC 45 Linke	Charniere complete SC 45 gauche