

SERIE 700

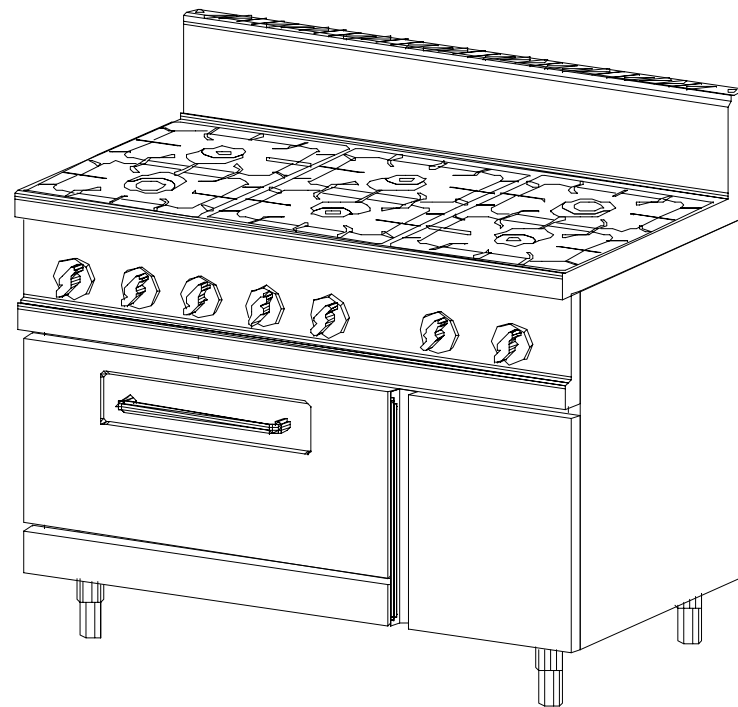

CUCINE A GAS CON PILOTA, SU FORNO ELETTRICO
GAS RANGES WITH PILOT LIGHT, ON ELECTRIC OVEN
GASHERDE MIT ZUENDFLAMMENBRENNER, MIT ELEKTROBACKOFEN
FORNEAUX GAZ AVEC PILOTE, AVEC FOUR ELECTRIQUE

da matricola - from serial
Nr.

a matricola - to serial
Nr.

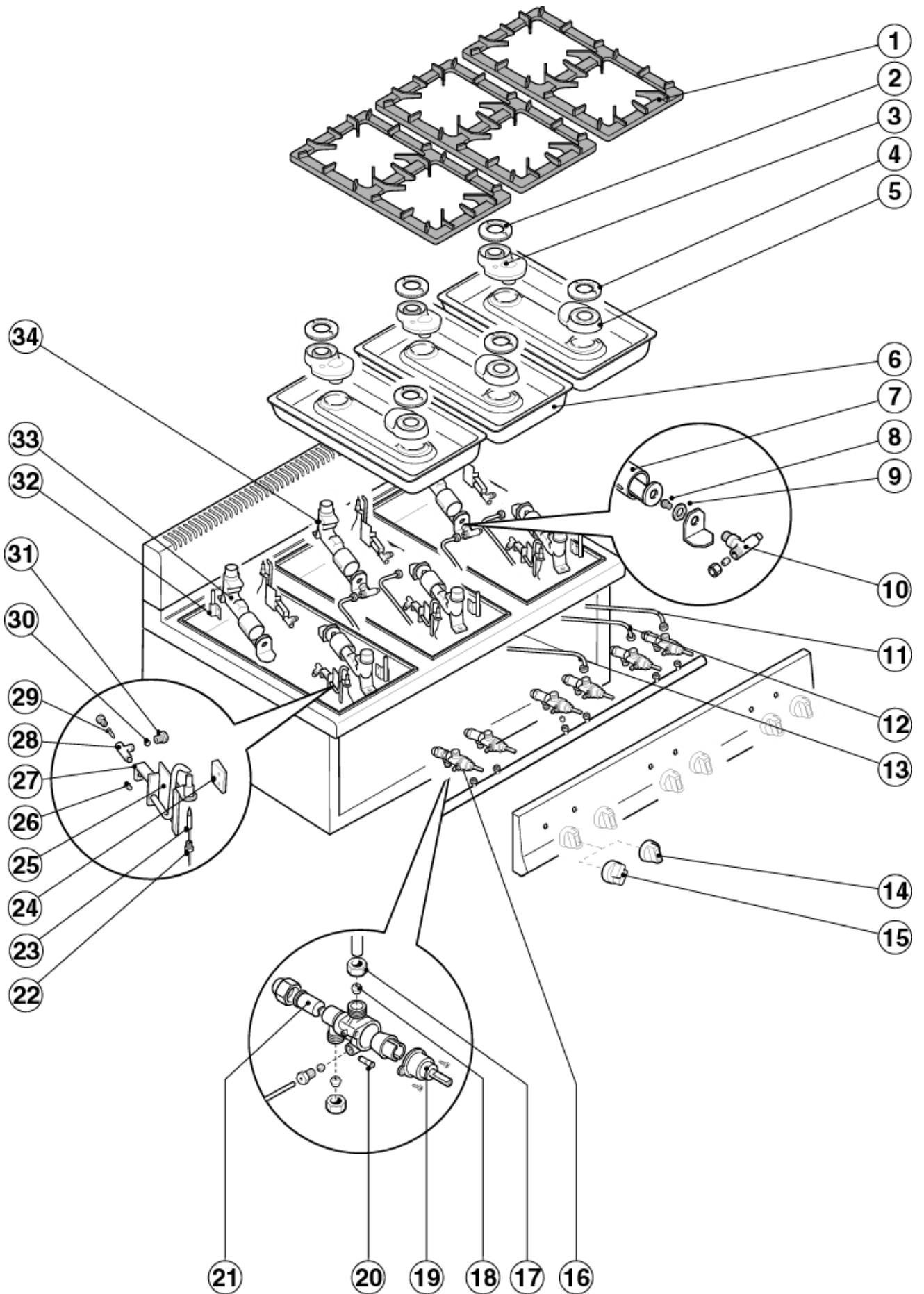

	COD.	REV.	DESCRIZIONE	DESCRIPTION	BESCHREIBUNG	DESCRIPTION
1	0101807		Griglia piano	Pan support	Auflagerost	Grille
2	0100251		Spartifiamma per bruciatore Ø 100	Flame-spreader for burner Ø 100	Brennerdeckel Ø 100	Couvercle pour brûleur Ø 100
3	0100223		Corpo bruciatore 5.5 kW	Body for 5.5 kW burner	Brennerkörper 5.5 kW	Corps pour brûleur 5.5 kW
4	0100252		Spartifiamma per bruciatore Ø 80	Flame-spreader for burner Ø 80	Brennerdeckel Ø 80	Couvercle pour brûleur Ø 80
5	0100225		Corpo bruciatore 3,5 kW	Body for 3,5 kW burner	Brennerkörper 3,5 kW	Corps pour brûleur 3,5 kW
6	LB847-00		Bacinella inox	Stainless steel top basin	Kochmulde aus Edelstahl	Plateau inox
7	0100264		Boccola aria primaria	Primary air bush	Luftschieber	Douille air primaire
8	Vedi tabella		Ugello	Nozzle	Düse	Gicleur
9	0100770		Dado M14x1 CH.18	Nut M14x1 CH.18	Mutter M14x1 CH.18	Ecrou M14x1 CH.18
10	0100767		Raccordo per ugello	Nozzle junction	Düsenverbindung	Raccord gicleur
11	LC671-00		Conduittura gas posteriore bruciatore 5.5 kW	Rear gas pipe 5.5 kW burner	Gasleitung hinten, 5.5 kW Brenner	Tube gaz arrière brûleur 5.5 kW
12	LC672-00		Conduittura gas anteriore bruciatore 3.5 kW	Front gas pipe 3.5 kW burner	Gasleitung vorne, 3.5 kW Brenner	Tube gaz avant brûleur 3.5 kW
13	LC670-00		Conduittura gas posteriore bruciatore 3.5 kW	Rear gas pipe 3.5 kW burner	Gasleitung hinten, 3.5 kW Brenner	Tube gaz arrière brûleur 3.5 kW
14	0101954		Manopola con tappo	Knob with insert	Knebel Ø 65 für offene Kochstellenbrenner mit Pfropfen	Manette Ø 65 pour feux vifs avec insert
15	0101798		Manopola "S"	Knob "S"	knebel "S" für offene Kochstellenbrenner	Manette "S" pour feux vifs
16	0100731	C	Rubinetto per fuochi aperti	Cock for open burners	Gasarmatur für offene Kochstellenbrenner	Robinet pour brûleur ouverts
17	0100774		Raccordo per conduittura gas Ø 10	Gas pipe fitting Ø 10	Verschraubung für Gasleitung Ø 10	Raccord pour tube gaz Ø 10
18	0100775		Bicono per conduittura gas Ø 10	Gas pipe bicone Ø 10	Doppelkegelring für Gasleitung Ø 10	Bicône pour tube gaz Ø 10
19	0100773		Cappuccio per rubinetti 21S	Cover	Verschlußkappe	Couvercle
20	Vedi tabella		By-pass	By-pass	By-pass	By-pass
21	0100752		Magnete	Magneto	Magnet	Magnéto
22	0100817		Raccordo per termocoppia	Thermocouple connection	Verschraubung für Thermoelement	Raccord pour couple thermo-électrique
23	0100808	C	Termocoppia L = 400 mm	Thermocouple L = 400 mm	Thermolement 400 mm lang	Couple thermo-électrique L = 400 mm
23a	0100809	C	Termocoppia L = 850 mm	Thermocouple L = 850 mm	Thermolement 850 mm lang	Couple thermo-électrique L = 850 mm
24	LC665-00		Distanziale per pilota bruciatore 3.5 kW	Spacer for 3.5 kW burner pilot	Abstandstück für 3.5 kW Pilotbrenner	Pièce entretoise pour pilote brûleur 3,5 kW
25	LC663-00		Assieme pilota	Pilot burner	Zündflammenbrenner	Brûleur pilote
26	0101151		Boccola regolazione aria	Air regulation bush	Luftregulierung Buechse	Douille regulation air
27	LC667-00		Squadretta fissaggio corpo pilota	Pilot fixing clamp	Pilotbefestigungsbuegel	Bride pilote
28	0101152	C	Corpo bruciatore con ugello	Body for burner with nozzle	Brennerkörper mit Düse	Corps pour brûleur avec gicleur
29	Vedi tabella		Ugello	Nozzle	Düse	Gicleur
30	0100745		Bicono pilota Ø 6	Bush for pilot Ø 6	Pilotdoppelkegelring Ø 6	Bicône brûleur d'allumage Ø 6
31	0100744		Dado pilota Ø 6	Nut for pilot Ø 6	Pilotmutter Ø 6	Ecrou brûleur d'allumage Ø 6
32	LC664-00		Assieme perno centraggio bruciatore	Burner centering dowel	Brennerzentrierstift	Pivot de centrage brûleur
33	0100302		Venturi per bruciatore 5.5 kW	Venturi tube for burner	Venturirohr für Brenner	Venturi pour brûleur
34	0100301		Venturi per bruciatore 3.5 kW	Venturi tube for burner	Venturirohr für Brenner	Venturi pour brûleur

TIPO DI BRUCIATORE	GAS	NAZIONI EN 203 - 1	PRESSIONE DI ALIMENTAZIONE	CODICE UGELLO Pos. 8	Ø 1/100	CODICE BY-PASS Pos. 20	Ø 1/100	CODICE UGELLO Pos. 29	Ø 1/100
C Qn = 3,5 kW	G 20	DK - FR - IT - ES	18 mbar	0100931	140	REGOLABILE	--	0101153	25
		DE - AT - FI - IE - PT - GB	20 mbar	0100931	140	REGOLABILE	--	0101153	25
	G 25	DE	20 mbar	0109072	155	REGOLABILE	--	0101153	25
		BE - FR - NL	25 mbar	0102009	146	REGOLABILE	--	0101153	25
	G 30	FR - IE - GB - ES - BE DK - IT - NL - PT - FI	28-30/37 mbar	0102010	90	REGOLABILE	--	0100829	20
		DE - AT	50 mbar	0100997	75 R	0102064	50	0100829	20
G 110	ES - DK - IT - SE - CH	8 mbar	0102043	270	REGOLABILE	--	--	--	
D Qn = 5,5 kW	G 20	DK - FR - IT - ES	18 mbar	0100932	175	REGOLABILE	--	0101153	25
		DE - AT - FI - IE - PT - GB	20 mbar	0100932	175	REGOLABILE	--	0101153	25
	G 25	DE	20 mbar	0102030	190	REGOLABILE	--	0101153	25
		BE - FR - NL	25 mbar	0102012	180	REGOLABILE	--	0101153	25
	G 30	FR - IE - GB - ES - BE DK - IT - NL - PT - FI	28-30/37 mbar	0100907	116	REGOLABILE	--	0100829	20
		DE - AT	50 mbar	0102013	95 R	0102063	60	0100829	20
G 110	ES - DK - IT - SE - CH	8 mbar	0102044	350	REGOLABILE	--	--	--	



da matricola - from serial
Nr.

a matricola - to serial
Nr.

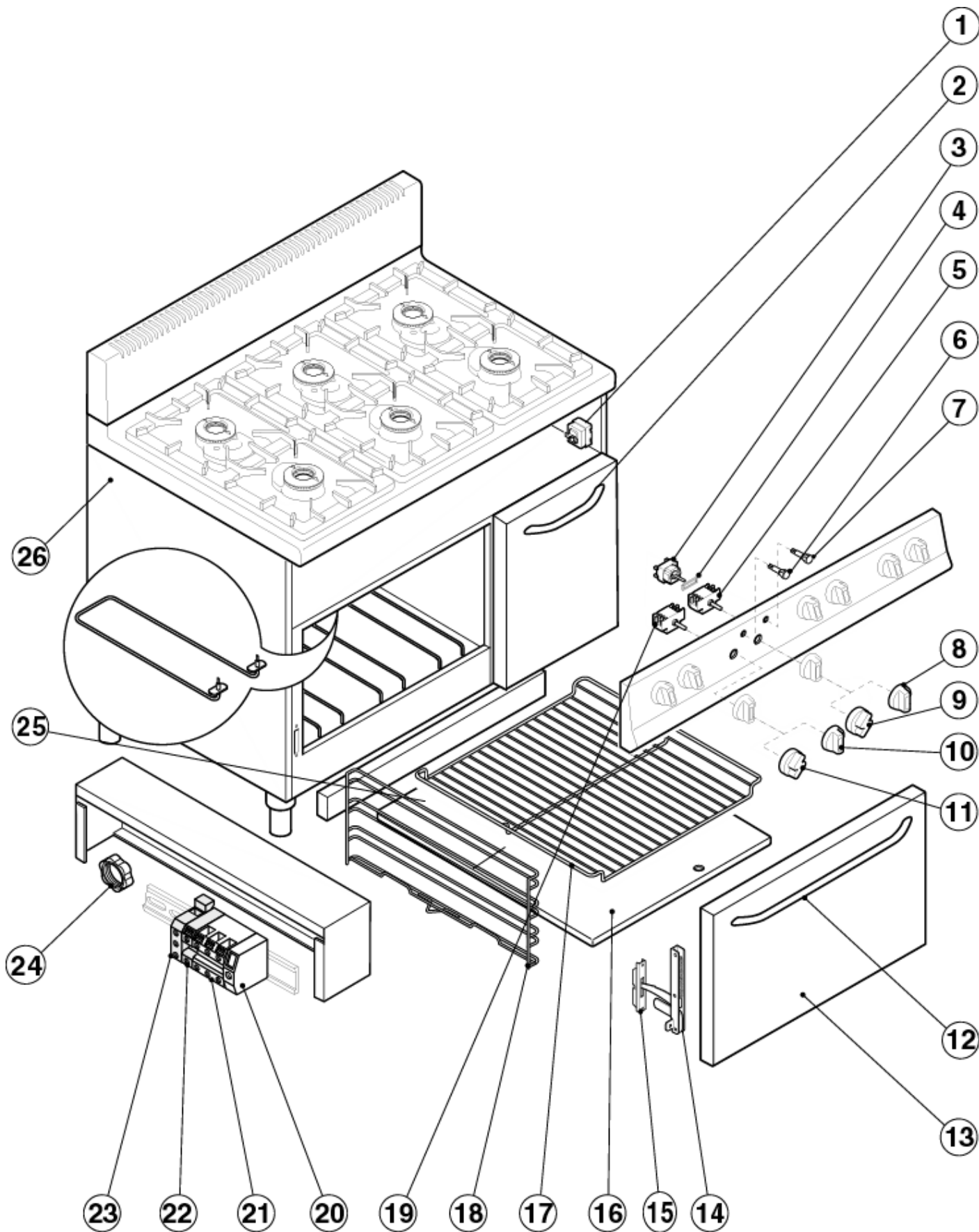

	COD.	REV.		DESCRIZIONE	DESCRIPTION	BESCHREIBUNG	DESCRIPTION
1	0101375		C	Termostato di sicurezza per forno	Electric oven safety thermostat	Sicherheitsthermostat, Backofen	Thermostat de sécurité pour le four
2a	LB385-00			Ass. portina	Cabinet door	Schränktür	Porte armoire
2b	LB968-00			Ass. portina armad. cucine versione "1"-2"	Cabinet door for ranges version 1-2	Schränktür für Herde Ausführung 1-2	Porte armoire p. fourneaux version 1-2
3	0101384		C	Termostato di funzionamento forno elettrico	Electric oven thermostat	Betriebsthermostat, Backofen	Thermostat de fonctionnement du four
4	0101378			Staffa EGO-617078	Clamp EGO-617078	Stütze EGO-617078	Etrier EGO-617078
5	0101379		C	Interruttore ON/OFF forno elettrico	Electric oven ON/OFF switch	EIN-AUS - Schalter, Backofen	Interrupteur ON/OFF four
6	0101169		C	Lampada spia verde	Green signal lamp	Kontrolleuchte grün	Voyant vert
7	0101167		C	Lampada spia arancione	Orange signal lamp	Kontrolleuchte orangefarbig	Voyant orange
8	0101956			Manopola Ø 65 per termostato 50°-310°C completa di tappo	Thermostatknob Ø 65 50°-310°C with insert	Thermostatknobel Ø 65 50°-310°C mit Pfropfen	Manette thermostat Ø 65 50°-310°C avec insert
9	0101789			Manopola "S" per termostato 50°-310°C	Thermostatknob "S" 50°-310°C	Thermostatknobel "S" 50°-310°C	Manette thermostat "S" 50°-310°C
10	0101955			Manopola Ø 65 per commutatore completa di tappo	Knob Ø 65 for changeover switch with insert	Knobel Ø 65 für Wahlschalter mit Pfropfen	Manette Ø 65 pour commutateur avec insert
11	0101788			Manopola "S" per commutatore	Knob "S" for changeover switch	Knobel "S" für Wahlschalter	Manette "S" pour commutateur
12	LB536-00			Maniglia porta	Oven door handle	Türgriff	Poignée porte
13	LB956-00			Ass. porta forno	Oven door	Backofentür	Porte four
14a	0100345		C	Cerniera compl. per SC45 SX	LH Hinge - SC 45	Komplettes Scharnier SC 45 SX	Charniere complete SC 45 SX
14b	0100346		C	Cerniera compl. per SC45 DX	RH Hinge - SC 45	Komplettes Scharnier SC 45 DX	Charniere complete SC 45 DX
15	0100343		C	Fermo per cerniera SC45 DX/SX	Hinge cover SC 45	Scharnierhalter SC 45 DX/SX	Arrêt p. charnière SC 45 DX/SX
16	LB537-00			Suola anteriore	Oven (front) base plate	Vorderer Ofenboden	Sole ant.
17	LB530-00	02		Griglia GN 2/1	GN 2/1 chrome wire grid	Rost GN 2/1	Grille GN 2/1
18a	LB533-00			Supporto sx griglia	Lh tray slides	Rostträger sx	Support grille sx
18b	LB532-00			Supporto dx griglia	Rh tray slides	Rostträger dx	Support grille dx
19	0101397		C	Selettore resistenze del forno elettrico	Oven heating elements switch	Wahlschalter für Backofen-Heizungen	Sélecteur des résistances du four
20	0101252			Morsetto unipolare (terra) 8WA1734	Unipolar terminal (earth) 8WA1734	Klemme einpolig (erde) 8WA1734	Borne unipolaire (terre) 8WA1734
21	0101251			Morsetto unipolare (neutro) 10111BK11	Unipolar terminal (neutral) 10111BK11	Klemme einpolig (neutral) 10111BK11	Borne unipolaire (neutre) 10111BK11
22	0101260			Morsetto tripolare (fase) 8WA1304	Three-pole terminal (phase) 8WA1304	Klemme dreipolig (phase) 8WA1304	Borne tripolaire (phase) 8WA1304
23	0101259			Morsetto terminale S8WA1808	Terminal S8WA1808	Endklemme S8WA1808	Borne terminale S8WA1808
24	0101303			Pressacavo	Cable fastener	Kabelpresse	Presse-cable
25	LB538-00			Suola posteriore	Oven (rear) base plate	Hintere Ofenboden	Sole post.
26	0101554		C	Resistenza forno 900W 230V	Oven heating element 900W 230V	Heizung, Backofen 900W 230V	Résistance four 900W 230V



COD. XES30725/M

PAG. 7/7