

**KTAR 01**

**KTAR 02**

**KTAR 03**

**KTAR 04**

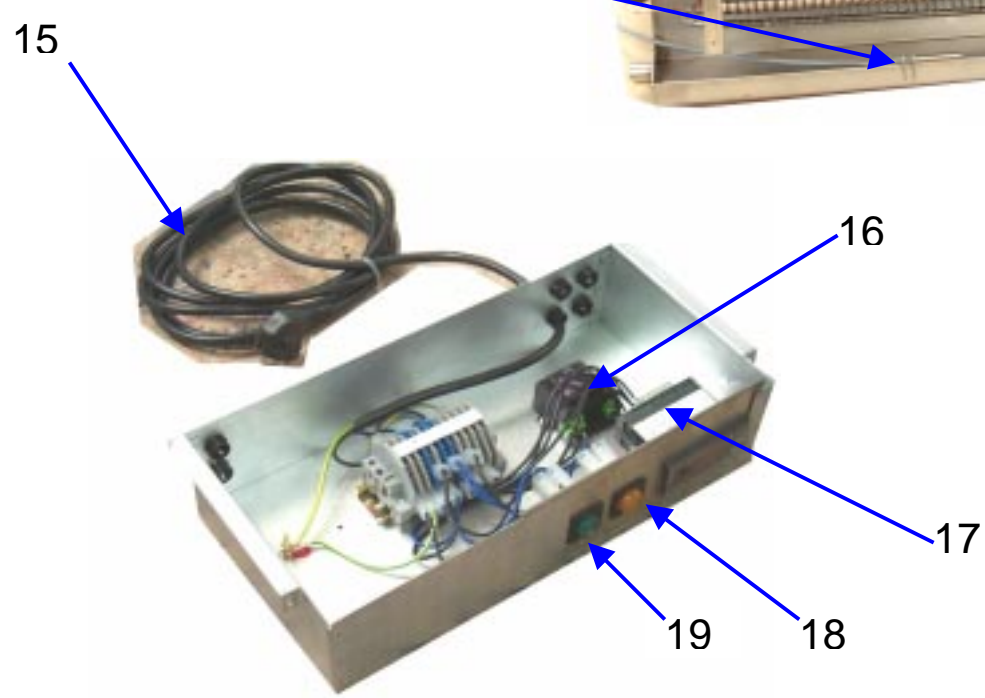
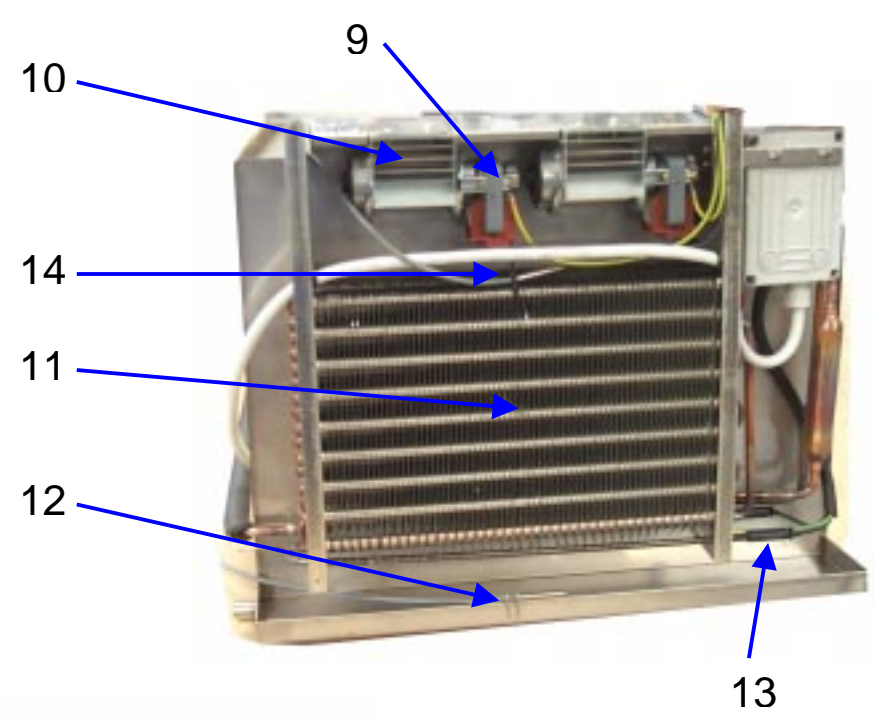
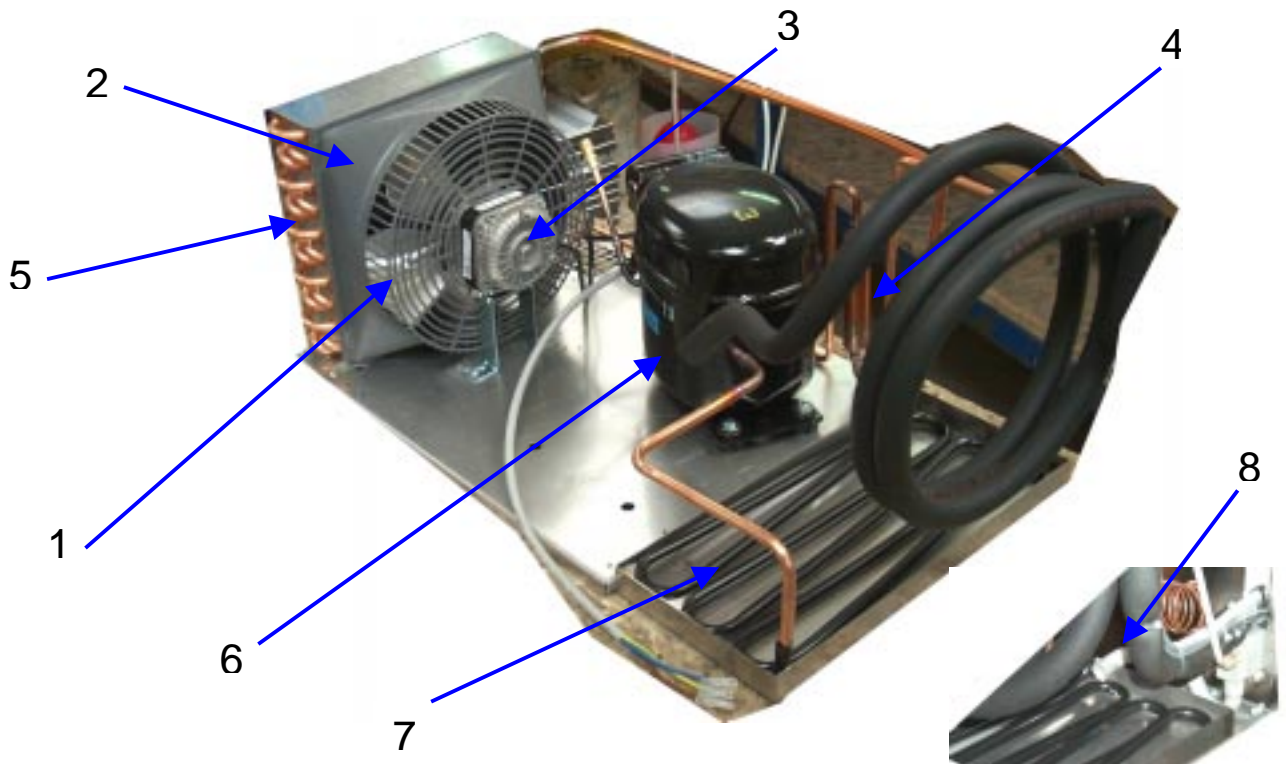

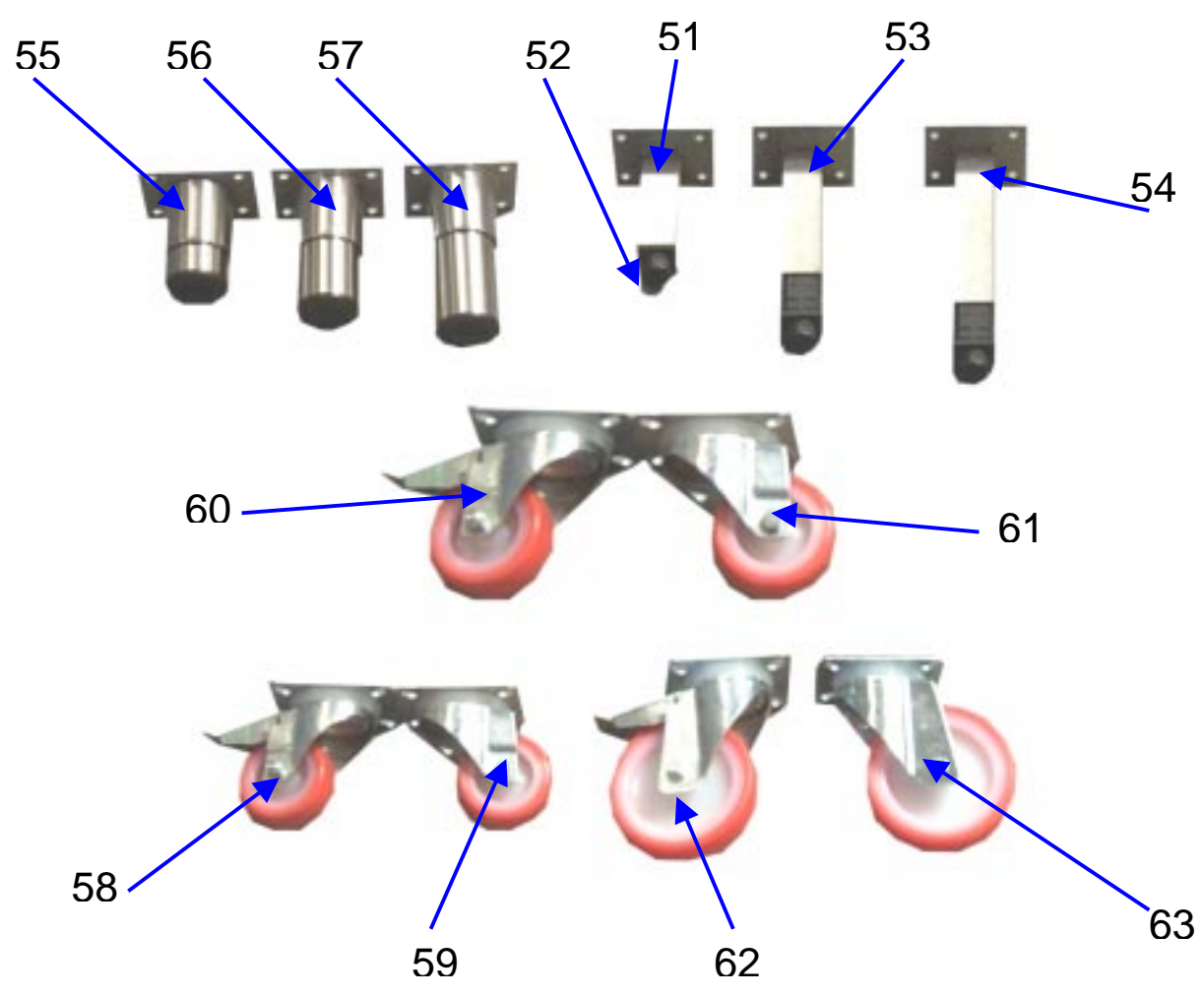
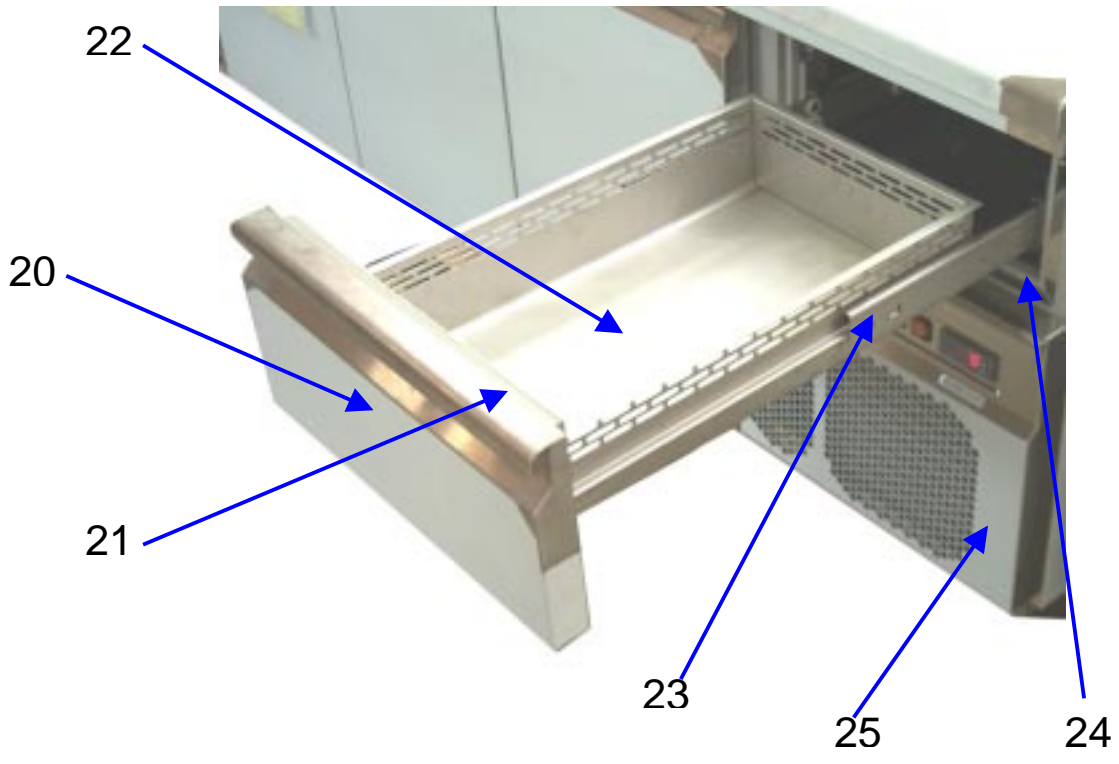

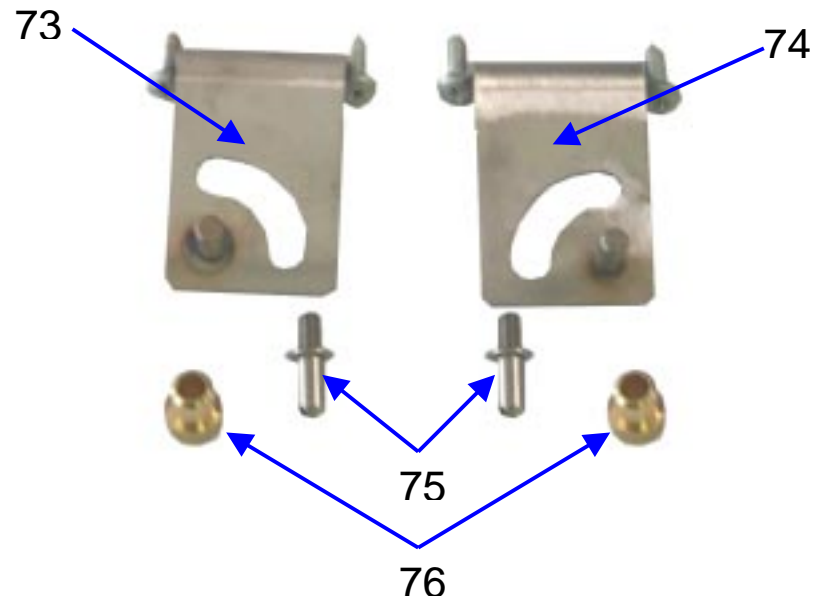
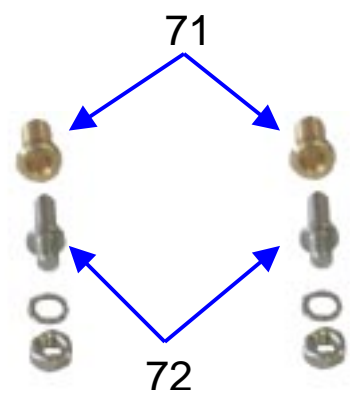
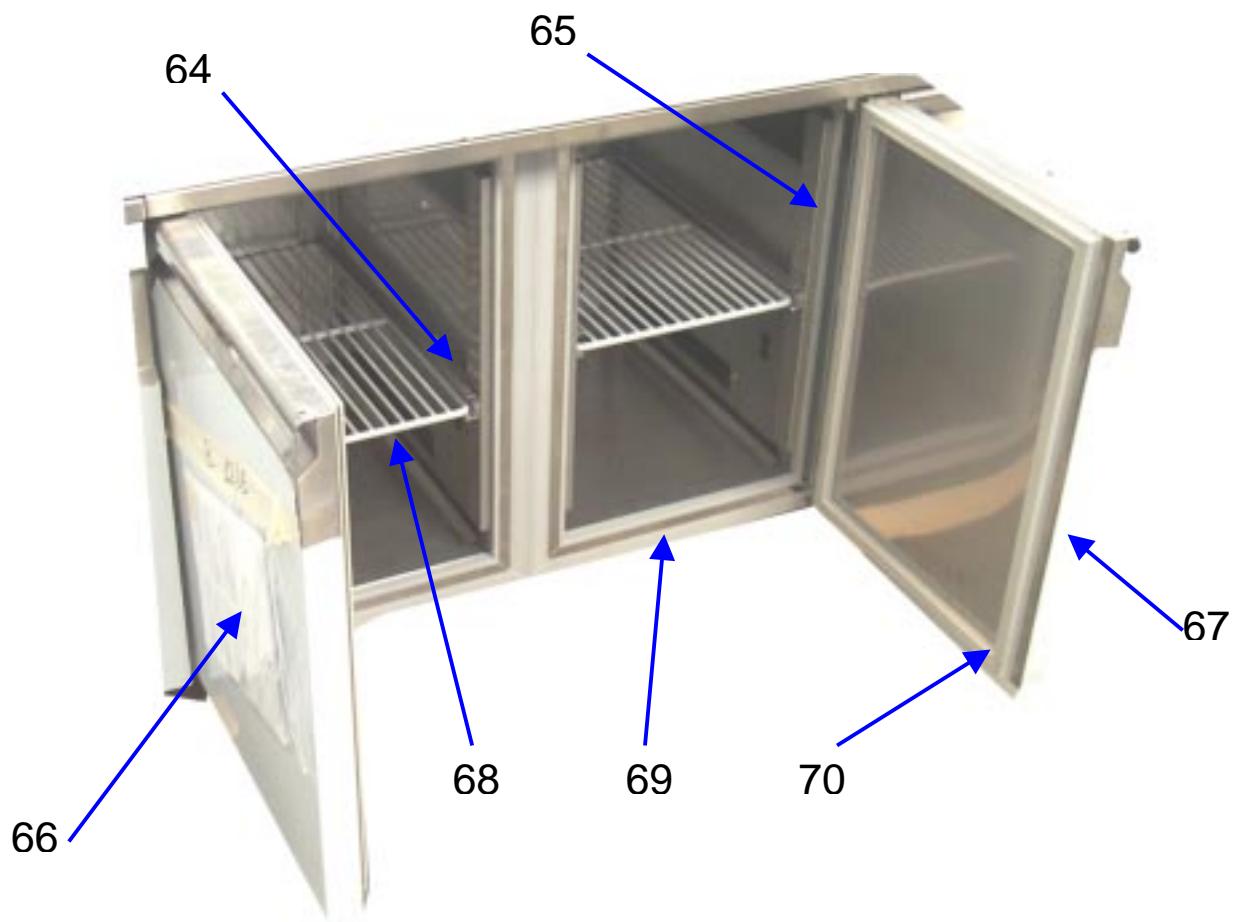

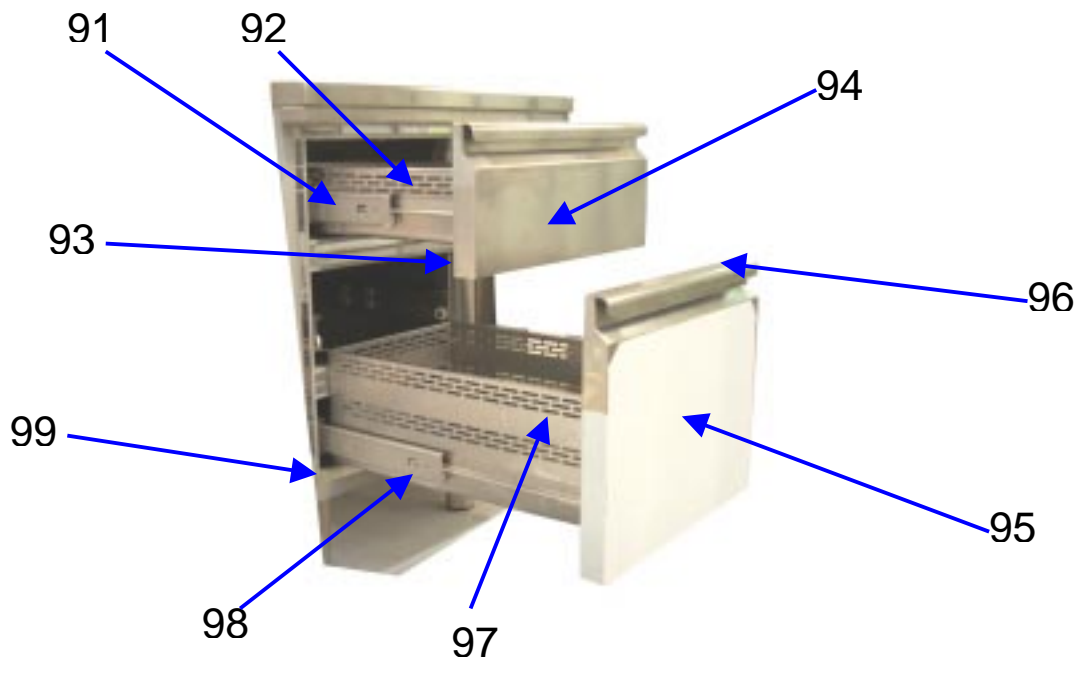
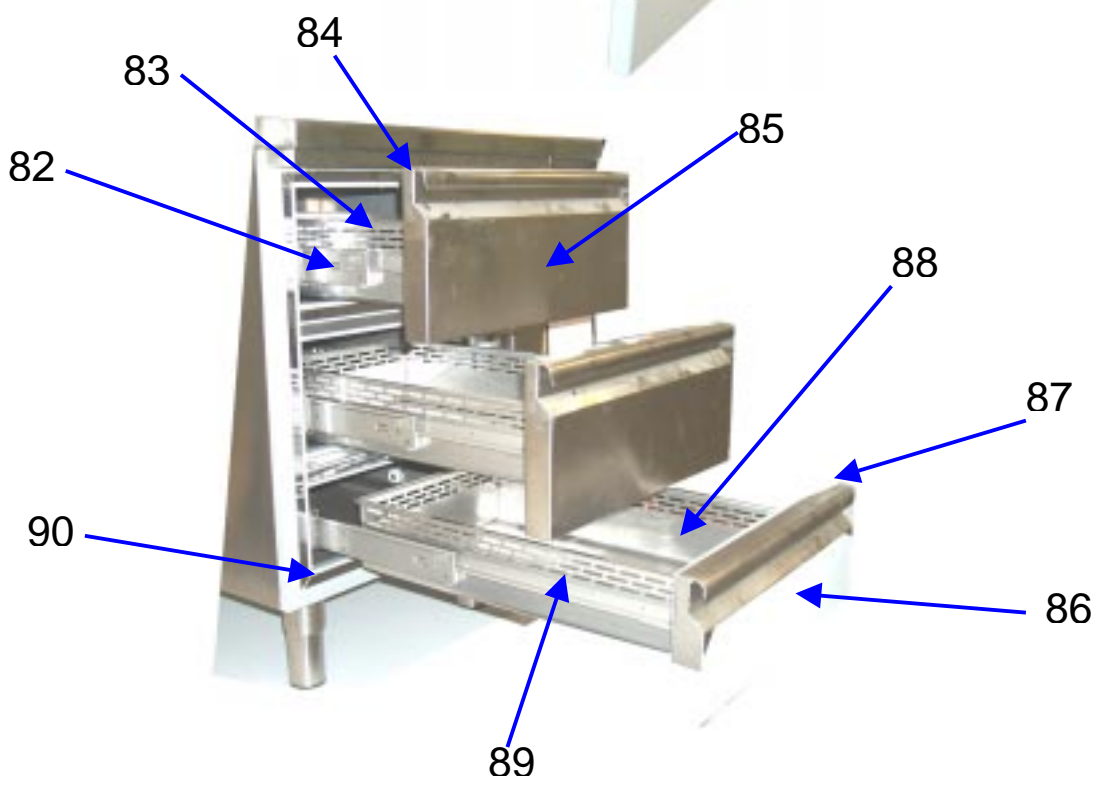
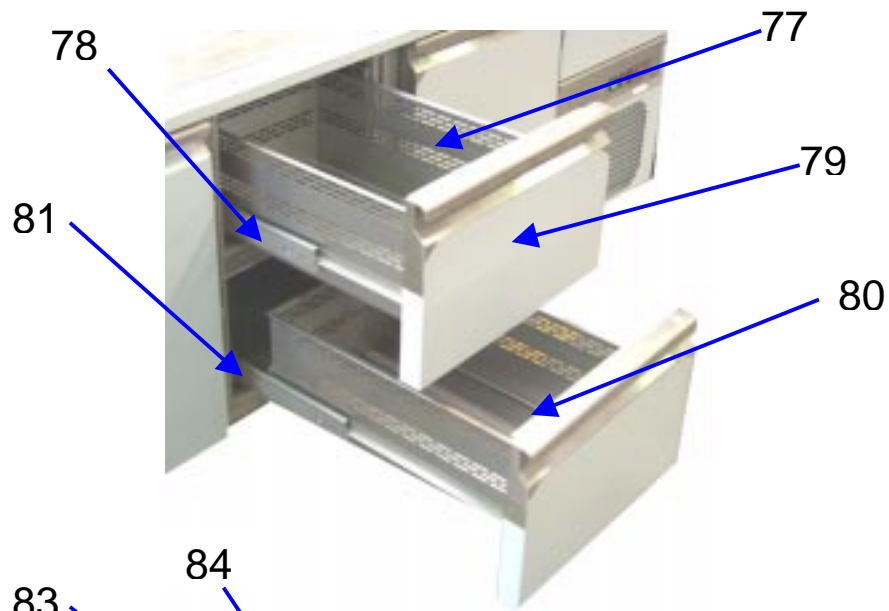



Code : **KTAR01**  
Model : **KTAR01**

N° CODE PZ DESCRIPTION

1,00	1495230034	0	Helical fan	230 34°
2,00	1417001	0	Pipe	
3,00	1648001010	0	Motor without bracket	
4,00	149125	0	Filter union	
5,00	141622424082	0	Air-cooled condenser	
6,00	141514200595	0	Compressor	220-240/1/50
7,00	149170	0	Compressor-condenser connection	
8,00	14923172	0	Drain trap	
9,00	1648106045	0	Motor-driven fan	
10,00	1440330	0	Fan protection grill	
11,00	14330210175	0	Evaporator	
12,00	167209	0	Sensor	
13,00	1666250	0	Evaporator defrost heater	250W
14,00	167209	0	Sensor	
15,00	1610056	0	Power cord	
16,00	168305	0	Transformer	
17,00	16811082	0	Thermostat	
18,00	1640010	0	Yellow defrost lamp	
19,00	1635110	0	High-brightness switch	
20,00	32241013	0	Convex panel - drawer	1/3 sup
21,00	14414300200	0	Drawer gasket	396x178 Cass.1/3
22,00	32531013	0	Drawer envelope	1/3
23,00	144907	0	Pair of telescopic slides	
24,00	1666013	0	Frame heater	13W
25,00	32573300	0	Control panel board	
51,00	1467522	0	Square foot	quadro
52,00	1467008	0	Thermoplastic snap-in foot	
53,00	1467524	0	Square foot	quadro
54,00	1467526	0	Square foot	quadro
55,00	1467504	0	Round foot	
56,00	1467506	0	Round foot	
57,00	1467508	0	Round foot	
58,00	147802	0	Caster with brake	ø80
59,00	147801	0	Caster	ø80
60,00	147806	0	Caster with brake	ø100
61,00	147805	0	Caster	ø100
62,00	147808	0	Caster with brake	ø125
63,00	147807	0	Caster	ø125
64,00	3351300100	0	Pair of slides for shelves	
65,00	3358300100	0	Slide holder upright	
66,00	32633100	0	Convex panel - half door	
67,00	32633100	0	Convex panel - half door	
68,00	1440053325	0	Wire shelf	530x325
69,00	1666022	0	Frame heater	22W
70,00	14414300620	0	Door gasket	396x566
71,00	140712153	0	Bushing	12x15
72,00	146610025	0	Door holding pin	10x25x6 M6
73,00	1412150	0	Lower hinge	sx
74,00	1412151	0	Lower hinge	dx
75,00	146606019	0	Door stop pin	
76,00	140712155	0	Bushing	12x15
77,00	32531012	0	Drawer envelope	1/2
78,00	144907	0	Pair of telescopic slides	
79,00	32241012	0	Convex panel - drawer	1/2
80,00	14414300290	0	Drawer gasket	396x266 Cass.1/2
81,00	1666022	0	Frame heater	22W
82,00	144907	0	Pair of telescopic slides	



Code : **KTAR01**

Model : **KTAR01**

N° CODE

PZ DESCRIPTION

---

83,00	32531013	0	Drawer envelope	1/3
84,00	14414300200	0	Drawer gasket	396x178 Cass.1/3
85,00	32241013	0	Convex panel - drawer	1/3 sup
86,00	322410131	0	Convex panel - drawer	1/3 inf
87,00	14414300150	0	Drawer gasket	396x142 Cass.1/3
88,00	32531013	0	Drawer envelope	1/3
89,00	144907	0	Pair of telescopic slides	
90,00	1666022	0	Frame heater	22W
91,00	144907	0	Pair of telescopic slides	
92,00	32531013	0	Drawer envelope	1/3
93,00	14414300200	0	Drawer gasket	396x178 Cass.1/3
94,00	32241013	0	Convex panel - drawer	1/3 sup
95,00	32241023	0	Convex panel - drawer	2/3
96,00	14414300390	0	Drawer gasket	396x354 Cass.2/3
97,00	32531012	0	Drawer envelope	1/2
98,00	144907	0	Pair of telescopic slides	
99,00	1666022	0	Frame heater	22W



Code : **KTAR02**  
Model : **KTAR02**

N° CODE PZ DESCRIPTION

1,00	1495230034	0	Helical fan	230 34°
2,00	1417001	0	Pipe	
3,00	1648001010	0	Motor without bracket	
4,00	149125	0	Filter union	
5,00	141622424083	0	Air-cooled condenser	
6,00	141514200800	0	Compressor	220-240/1/50
7,00	149170	0	Compressor-condenser connection	
8,00	14923172	0	Drain trap	
9,00	1648106045	0	Motor-driven fan	
10,00	1440330	0	Fan protection grill	
11,00	14330210171	0	Evaporator	
12,00	167209	0	Sensor	
13,00	1666250	0	Evaporator defrost heater	250W
14,00	167209	0	Sensor	
15,00	1610056	0	Power cord	
16,00	168305	0	Transformer	
17,00	16811082	0	Thermostat	
18,00	1640010	0	Yellow defrost lamp	
19,00	1635110	0	High-brightness switch	
20,00	32241013	0	Convex panel - drawer	1/3 sup
21,00	14414300200	0	Drawer gasket	396x178 Cass.1/3
22,00	32531013	0	Drawer envelope	1/3
23,00	144907	0	Pair of telescopic slides	
24,00	1666013	0	Frame heater	13W
25,00	32573300	0	Control panel board	
51,00	1467522	0	Square foot	quadro
52,00	1467008	0	Thermoplastic snap-in foot	
53,00	1467524	0	Square foot	quadro
54,00	1467526	0	Square foot	quadro
55,00	1467504	0	Round foot	
56,00	1467506	0	Round foot	
57,00	1467508	0	Round foot	
58,00	147802	0	Caster with brake	ø80
59,00	147801	0	Caster	ø80
60,00	147806	0	Caster with brake	ø100
61,00	147805	0	Caster	ø100
62,00	147808	0	Caster with brake	ø125
63,00	147807	0	Caster	ø125
64,00	3351300100	0	Pair of slides for shelves	
65,00	3358300100	0	Slide holder upright	
66,00	32633100	0	Convex panel - half door	
67,00	32633100	0	Convex panel - half door	
68,00	1440053325	0	Wire shelf	530x325
69,00	1666022	0	Frame heater	22W
70,00	14414300620	0	Door gasket	396x566
71,00	140712153	0	Bushing	12x15
72,00	146610025	0	Door holding pin	10x25x6 M6
73,00	1412150	0	Lower hinge	sx
74,00	1412151	0	Lower hinge	dx
75,00	146606019	0	Door stop pin	
76,00	140712155	0	Bushing	12x15
77,00	32531012	0	Drawer envelope	1/2
78,00	144907	0	Pair of telescopic slides	
79,00	32241012	0	Convex panel - drawer	1/2
80,00	14414300290	0	Drawer gasket	396x266 Cass.1/2
81,00	1666022	0	Frame heater	22W
82,00	144907	0	Pair of telescopic slides	





Code : **KTAR02**

Model : **KTAR02**

N° CODE

PZ DESCRIPTION

---

83,00	32531013	0	Drawer envelope	1/3
84,00	14414300200	0	Drawer gasket	396x178 Cass.1/3
85,00	32241013	0	Convex panel - drawer	1/3 sup
86,00	322410131	0	Convex panel - drawer	1/3 inf
87,00	14414300150	0	Drawer gasket	396x142 Cass.1/3
88,00	32531013	0	Drawer envelope	1/3
89,00	144907	0	Pair of telescopic slides	
90,00	1666022	0	Frame heater	22W
91,00	144907	0	Pair of telescopic slides	
92,00	32531013	0	Drawer envelope	1/3
93,00	14414300200	0	Drawer gasket	396x178 Cass.1/3
94,00	32241013	0	Convex panel - drawer	1/3 sup
95,00	32241023	0	Convex panel - drawer	2/3
96,00	14414300390	0	Drawer gasket	396x354 Cass.2/3
97,00	32531012	0	Drawer envelope	1/2
98,00	144907	0	Pair of telescopic slides	
99,00	1666022	0	Frame heater	22W



Code : **KTAR03**  
Model : **KTAR03**

N° CODE PZ DESCRIPTION

1,00	1495230034	0	Helical fan	230 34°
2,00	1417001	0	Pipe	
3,00	1648001010	0	Motor without bracket	
4,00	149125	0	Filter union	
5,00	141622424083	0	Air-cooled condenser	
6,00	141514200800	0	Compressor	220-240/1/50
7,00	149170	0	Compressor-condenser connection	
8,00	14923172	0	Drain trap	
9,00	1648106045	0	Motor-driven fan	
10,00	1440330	0	Fan protection grill	
11,00	14330210171	0	Evaporator	
12,00	167211	0	Sensor	
13,00	1666250	0	Evaporator defrost heater	250W
14,00	167211	0	Sensor	
15,00	1610056	0	Power cord	
16,00	168305	0	Transformer	
17,00	16811102	0	Thermostat	
18,00	1640010	0	Yellow defrost lamp	
19,00	1635110	0	High-brightness switch	
20,00	32241013	0	Convex panel - drawer	1/3 sup
21,00	14414300200	0	Drawer gasket	396x178 Cass.1/3
22,00	32531013	0	Drawer envelope	1/3
23,00	144907	0	Pair of telescopic slides	
24,00	1666013	0	Frame heater	13W
25,00	32573300	0	Control panel board	
51,00	1467522	0	Square foot	quadro
52,00	1467008	0	Thermoplastic snap-in foot	
53,00	1467524	0	Square foot	quadro
54,00	1467526	0	Square foot	quadro
55,00	1467504	0	Round foot	
56,00	1467506	0	Round foot	
57,00	1467508	0	Round foot	
58,00	147802	0	Caster with brake	ø80
59,00	147801	0	Caster	ø80
60,00	147806	0	Caster with brake	ø100
61,00	147805	0	Caster	ø100
62,00	147808	0	Caster with brake	ø125
63,00	147807	0	Caster	ø125
64,00	3351300100	0	Pair of slides for shelves	
65,00	3358300100	0	Slide holder upright	
66,00	32633100	0	Convex panel - half door	
67,00	32633100	0	Convex panel - half door	
68,00	1440053325	0	Wire shelf	530x325
69,00	1666022	0	Frame heater	22W
70,00	14414300620	0	Door gasket	396x566
71,00	140712153	0	Bushing	12x15
72,00	146610025	0	Door holding pin	10x25x6 M6
73,00	1412150	0	Lower hinge	sx
74,00	1412151	0	Lower hinge	dx
75,00	146606019	0	Door stop pin	
76,00	140712155	0	Bushing	12x15
77,00	32531012	0	Drawer envelope	1/2
78,00	144907	0	Pair of telescopic slides	
79,00	32241012	0	Convex panel - drawer	1/2
80,00	14414300290	0	Drawer gasket	396x266 Cass.1/2
81,00	1666022	0	Frame heater	22W
82,00	144907	0	Pair of telescopic slides	



Code : **KTAR03**

Model : **KTAR03**

N° CODE

PZ DESCRIPTION

---

83,00	32531013	0	Drawer envelope	1/3
84,00	14414300200	0	Drawer gasket	396x178 Cass.1/3
85,00	32241013	0	Convex panel - drawer	1/3 sup
86,00	322410131	0	Convex panel - drawer	1/3 inf
87,00	14414300150	0	Drawer gasket	396x142 Cass.1/3
88,00	32531013	0	Drawer envelope	1/3
89,00	144907	0	Pair of telescopic slides	
90,00	1666022	0	Frame heater	22W
91,00	144907	0	Pair of telescopic slides	
92,00	32531013	0	Drawer envelope	1/3
93,00	14414300200	0	Drawer gasket	396x178 Cass.1/3
94,00	32241013	0	Convex panel - drawer	1/3 sup
95,00	32241023	0	Convex panel - drawer	2/3
96,00	14414300390	0	Drawer gasket	396x354 Cass.2/3
97,00	32531012	0	Drawer envelope	1/2
98,00	144907	0	Pair of telescopic slides	
99,00	1666022	0	Frame heater	22W



Code : **KTAR04**  
Model : **KTAR04**

N° CODE PZ DESCRIPTION

1,00	1495230034	0	Helical fan	230 34°
2,00	1417001	0	Pipe	
3,00	1648001010	0	Motor without bracket	
4,00	149125	0	Filter union	
5,00	141622424083	0	Air-cooled condenser	
6,00	141514208850	0	Compressor	220-240/1/50
7,00	149170	0	Compressor-condenser connection	
8,00	14923172	0	Drain trap	
9,00	1648106045	0	Motor-driven fan	
10,00	1440330	0	Fan protection grill	
11,00	14330210171	0	Evaporator	
12,00	167211	0	Sensor	
13,00	1666250	0	Evaporator defrost heater	250W
14,00	167211	0	Sensor	
15,00	1610056	0	Power cord	
16,00	168305	0	Transformer	
17,00	16811102	0	Thermostat	
18,00	1640010	0	Yellow defrost lamp	
19,00	1635110	0	High-brightness switch	
20,00	32241013	0	Convex panel - drawer	1/3 sup
21,00	14414300200	0	Drawer gasket	396x178 Cass.1/3
22,00	32531013	0	Drawer envelope	1/3
23,00	144907	0	Pair of telescopic slides	
24,00	1666013	0	Frame heater	13W
25,00	32573300	0	Control panel board	
51,00	1467522	0	Square foot	quadro
52,00	1467008	0	Thermoplastic snap-in foot	
53,00	1467524	0	Square foot	quadro
54,00	1467526	0	Square foot	quadro
55,00	1467504	0	Round foot	
56,00	1467506	0	Round foot	
57,00	1467508	0	Round foot	
58,00	147802	0	Caster with brake	ø80
59,00	147801	0	Caster	ø80
60,00	147806	0	Caster with brake	ø100
61,00	147805	0	Caster	ø100
62,00	147808	0	Caster with brake	ø125
63,00	147807	0	Caster	ø125
64,00	3351300100	0	Pair of slides for shelves	
65,00	3358300100	0	Slide holder upright	
66,00	32633100	0	Convex panel - half door	
67,00	32633100	0	Convex panel - half door	
68,00	1440053325	0	Wire shelf	530x325
69,00	1666022	0	Frame heater	22W
70,00	14414300620	0	Door gasket	396x566
71,00	140712153	0	Bushing	12x15
72,00	146610025	0	Door holding pin	10x25x6 M6
73,00	1412150	0	Lower hinge	sx
74,00	1412151	0	Lower hinge	dx
75,00	146606019	0	Door stop pin	
76,00	140712155	0	Bushing	12x15
77,00	32531012	0	Drawer envelope	1/2
78,00	144907	0	Pair of telescopic slides	
79,00	32241012	0	Convex panel - drawer	1/2
80,00	14414300290	0	Drawer gasket	396x266 Cass.1/2
81,00	1666022	0	Frame heater	22W
82,00	144907	0	Pair of telescopic slides	



Code : **KTAR04**

Model : **KTAR04**

N° CODE

PZ DESCRIPTION

---

83,00	32531013	0	Drawer envelope	1/3
84,00	14414300200	0	Drawer gasket	396x178 Cass.1/3
85,00	32241013	0	Convex panel - drawer	1/3 sup
86,00	322410131	0	Convex panel - drawer	1/3 inf
87,00	14414300150	0	Drawer gasket	396x142 Cass.1/3
88,00	32531013	0	Drawer envelope	1/3
89,00	144907	0	Pair of telescopic slides	
90,00	1666022	0	Frame heater	22W
91,00	144907	0	Pair of telescopic slides	
92,00	32531013	0	Drawer envelope	1/3
93,00	14414300200	0	Drawer gasket	396x178 Cass.1/3
94,00	32241013	0	Convex panel - drawer	1/3 sup
95,00	32241023	0	Convex panel - drawer	2/3
96,00	14414300390	0	Drawer gasket	396x354 Cass.2/3
97,00	32531012	0	Drawer envelope	1/2
98,00	144907	0	Pair of telescopic slides	
99,00	1666022	0	Frame heater	22W