

MOD.

OPLG-40 CR0501040
OPLG-80 CR0501050

GRIGLIA BISTECCHIERA (A PIETRA LAVICA) A GAS

GAS HEATED CHAR GRILL

GRILLADE CHARCOAL A GAZ

GASBEHEIZTE GLÜHSTEINGERAT

1041301900 (40)
1041301200 (80)

1036200400
(Kg 13)

1829522

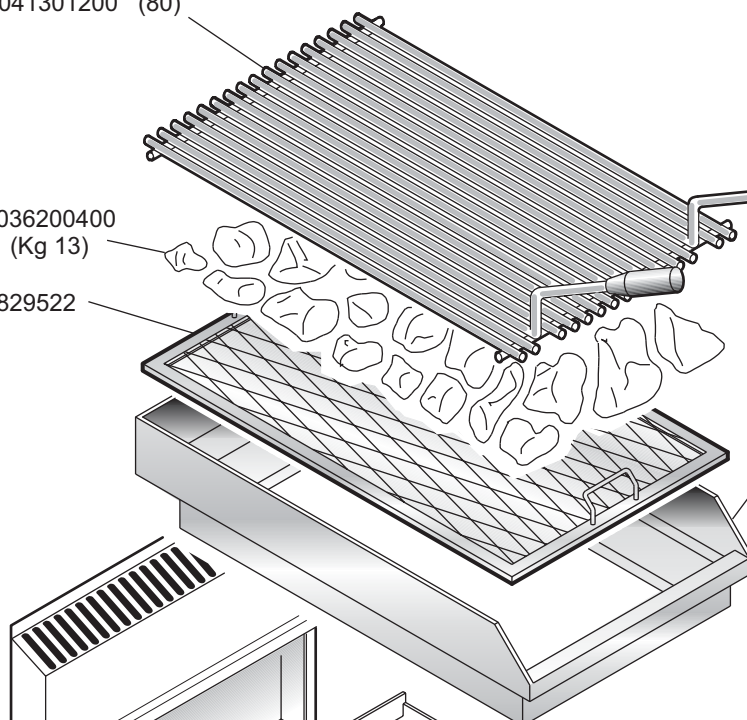

1829200

1888000 N. 14 □ ■
1887800 N. 27 ○ ● ▲
1887900 N. 50 + +

1864600 (40)
1830114 (80)

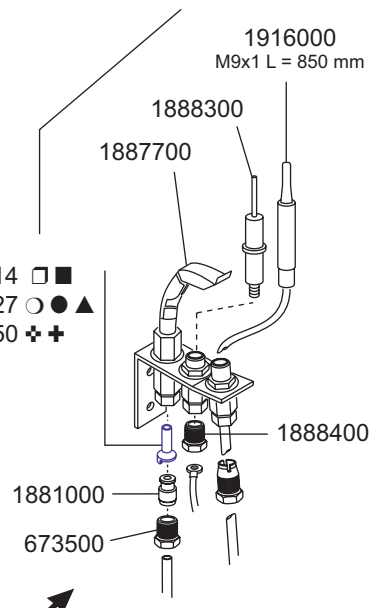

1916000
M9x1 L = 850 mm

1888300

1887700

1888400

1881000

673500

521611 Ø 115 □
521911 Ø 130 ■
523411 Ø 205 ○ ●
523711 Ø 220 ▲
526411 Ø 420 +
527011 Ø 480 +

1828112

1043001400

1041105212

1033114300 (40)
1033114100 (80) ▶
1033114200 ◀(80)

CM021700

86720

673500

673600

1033114500 (40)
1033114400 (80)

1036021613

1359100

86720

1326500

86720

1031501300

CR0501380 (40)
CR0501390 (80)

1936300
(L = 600 mm)

CR0502240

1036712600

MA1036609900

(*) By-pass

Ø 90 - 1033720200 □ ■
Ø 140 - 1883400 ○ ● ▲

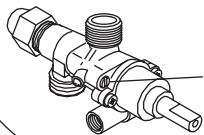

ID GAS: □ G30/50 ■ G30/28+37 ○ G20/20 ● G25/25 ▲ G25/20 + G120/8 + G110/8

	ELABORATO:	APPROVATO:	GRUPPO:	DENOMINAZIONE:		
	LZ		Serie 600 Snack	Impianto gas - Mobile		
	DATA:	DATA:	PARTICOLARE:	REV. N.	DEL	DISEGNO N.
	18 Lug 2005	18 Lug 2005	Disegno esploso per ricambi	▼ Z00	▼ 0705	▼ 30L.6.07
SOST. DIS.						