

GAS GRIDDLE PLATES 900 Series

MODELS WITH TAP
MODELS WITH VALVE

TYPE: 9FT/G400, 9FTT/G400, 9FTT/G405, 9FT/G410, 9FTT/G410, 9FTT/G415, 9FT/G800, 9FTT/G800, 9FTT/G805, 9FT/G810, 9FTT/G810, 9FTT/G815, 9FT/G820, 9FTT/G820, 9FTT/G825, 9FTV/G400, 9FTTV/G400, 9FTTV/G405, 9FTV/G410, 9FTTV/G410, 9FTTV/G415, 9FTTV/G800, 9FTTV/G805, 9FTV/G810, 9FTTV/G810, 9FTTV/G815, 9FTV/G820, 9FTTF/G800, 9FTTF/GE800, 9FTTF/G820, 9FTTF/GE820, 9FTTF/GE805, 9FTTF/GE825

Spare parts



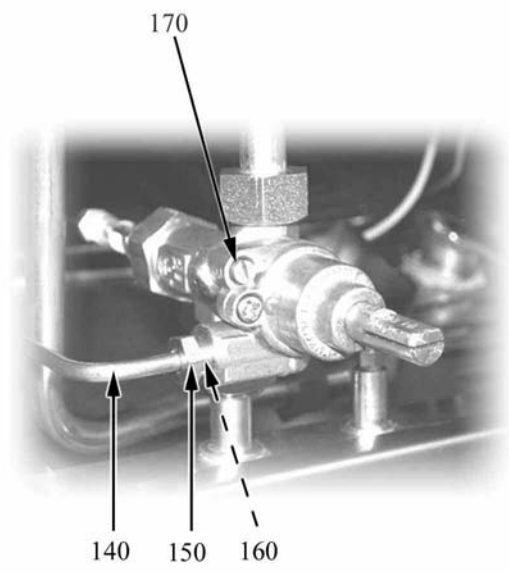
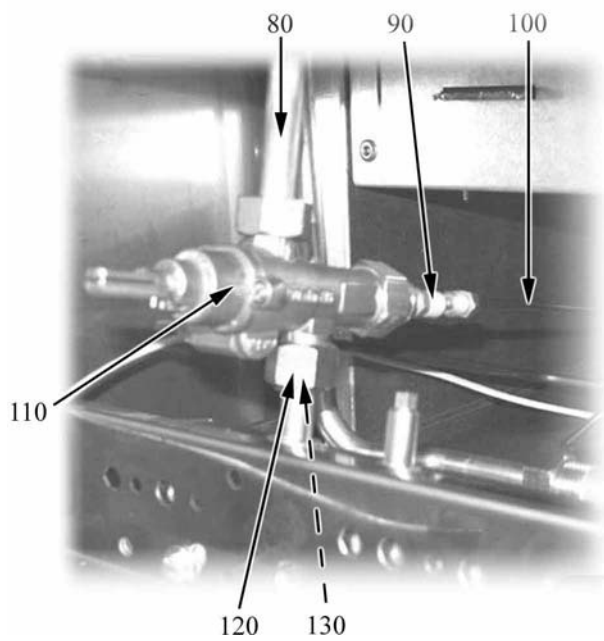

Spare parts

ID	Models	Type	Description	P-code
Module: External parts and tap				
10			Foot	826490142
20			Lower right upper left door hinge	826410020
30			Lower left upper right door hinge	826410010
40			Piezoelectric ignition	6A041105
41			washer	822160540
42			Cap	826630420
50			Magnet	826900011
60	RUB		Black knob for gas range	2599200
70	VAL	9FTT825,9FTTFE825	Plate	826470010
70	VAL	9FTT805,9FTTV805,9FTTF805, 9FTTF805,9FTTFE805	Plate	826470020
70	VAL	9FTT405,9FTTV405	Plate	826470050
70		9FT800,9FTV800,9FTV800	Plate	826470150
70		9FT400,9FTV400	Plate	826470160
70		9FT410,9FTV410	Plate	826470230
70		9FT820,9FTV820	Plate	826470240
70		9FT810,9FTV810	Plate	826470540
70	VAL	9FTT415,9FTTV415	Plate	826470570
70	VAL	9FTT815,9FTTV815	Plate	826470580
80	RUB		Right pipe	823560511
80	RUB		Town gas right pipe	2515176
80	RUB		Left pipe	823560213
90	RUB		Pipe fitting	6A013401
100	RUB		Termocuple	6A011904
110	RUB		Tap	6A011490
110	RUB		Town gas tap	6A011490
120	RUB		Nut	6A011850
130	RUB		Ogive	6A011480
140	RUB		Pipe	823560490

RUB= MODELS WITH TAP, VAL=MODELS WITH VALVE

9FT400=9FT/G400, 9FTT400=9FTT/G400, 9FTT405=9FTT/G405, 9FT410=9FT/G410, 9FTT410=9FTT/G410,
 9FTT415=9FTT/G415, 9FT800=9FT/G800, 9FTT800=9FTT/G800, 9FTT805=9FTT/G805, 9FT810=9FT/G810,
 9FTT810=9FTT/G810, 9FTT815=9FTT/G815, 9FT820=9FT/G820, 9FTT820=9FTT/G820, 9FTT825=9FTT/G825,
 9FTV400=9FTV/G400, 9FTTV400=9FTTV/G400, 9FTTV405=9FTTV/G405, 9FTV410=9FTV/G410,
 9FTTV410=9FTTV/G410, 9FTTV415= 9FTTV/G415, 9FTTV800=9FTTV/G800, 9FTTV805=9FTTV/G805,
 9FTV810=9FTV/G810, 9FTTV810= 9FTTV/G810, 9FTTV815=9FTTV/G815, 9FTV820=9FTV/G820,
 9FTTF800=9FTTF/G800, 9FTTFE800=9FTTF/GE800, 9FTTF820=9FTTF/G820, 9FTTFE820=9FTTF/GE820,
 9FTTFE805=9FTTF/GE805, 9FTTFE825=9FTTF/GE825

A=3/N/PE~400/230V 50Hz

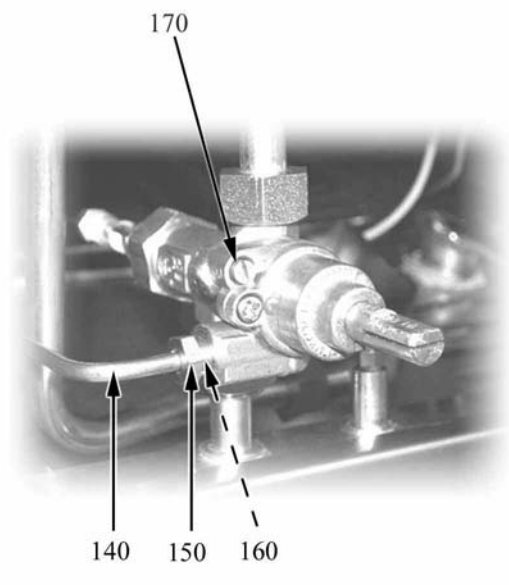
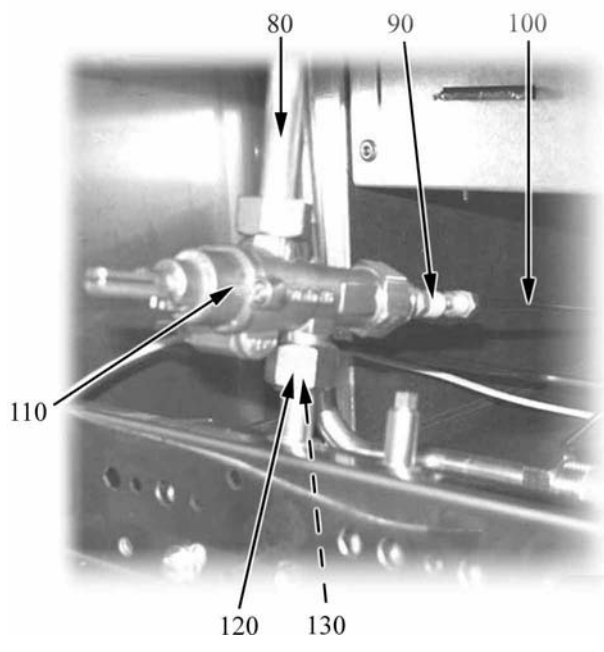

Spare parts

ID	Models	Type	Description	P-code
Module: External parts and tap				
140	RUB		Pipe	823560230
150	RUB		Nut	6A016110
160	RUB		Ogive	6A016120
170	RUB		By-pass 90	822450260
170	RUB		By-pass 80	822450240
170	RUB		By-pass 135	822450300
170	RUB		By-pass 160	822450310
170	RUB		By-pass 125	822450690

RUB= MODELS WITH TAP, VAL=MODELS WITH VALVE

9FT400=9FT/G400, 9FTT400=9FTT/G400, 9FTT405=9FTT/G405, 9FT410=9FT/G410, 9FTT410=9FTT/G410,
 9FTT415=9FTT/G415, 9FT800=9FT/G800, 9FTT800=9FTT/G800, 9FTT805=9FTT/G805, 9FT810=9FT/G810,
 9FTT810=9FTT/G810, 9FTT815=9FTT/G815, 9FT820=9FT/G820, 9FTT820=9FTT/G820, 9FTT825=9FTT/G825,
 9FTV400=9FTV/G400, 9FTTV400=9FTTV/G400, 9FTTV405=9FTTV/G405, 9FTV410=9FTV/G410,
 9FTTV410=9FTTV/G410, 9FTTV415= 9FTTV/G415, 9FTTV800=9FTTV/G800, 9FTTV805=9FTTV/G805,
 9FTV810=9FTV/G810, 9FTTV810= 9FTTV/G810, 9FTTV815=9FTTV/G815, 9FTV820=9FTV/G820,
 9FTTF800=9FTTF/G800, 9FTTFE800=9FTTF/GE800, 9FTTF820=9FTTF/G820, 9FTTFE820=9FTTF/GE820,
 9FTTFE805=9FTTF/GE805, 9FTTFE825=9FTTF/GE825

A=3/N/PE~400/230V 50Hz

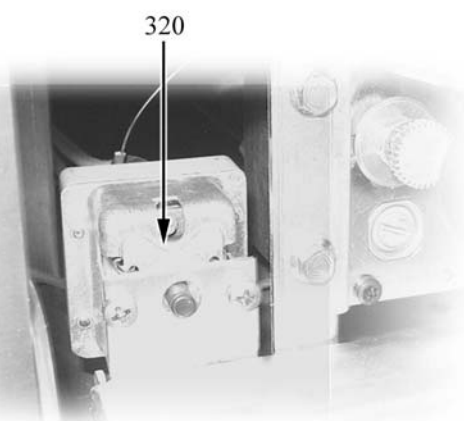
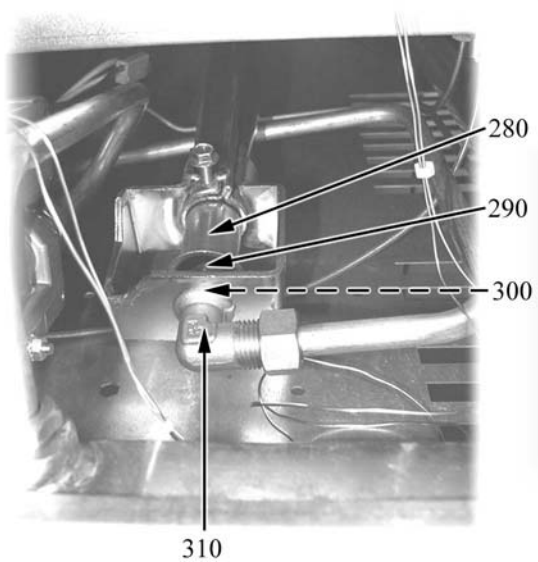
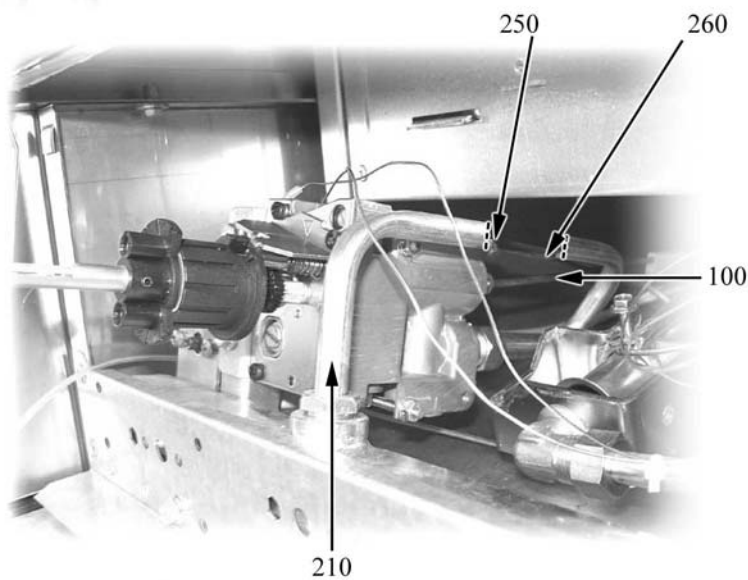
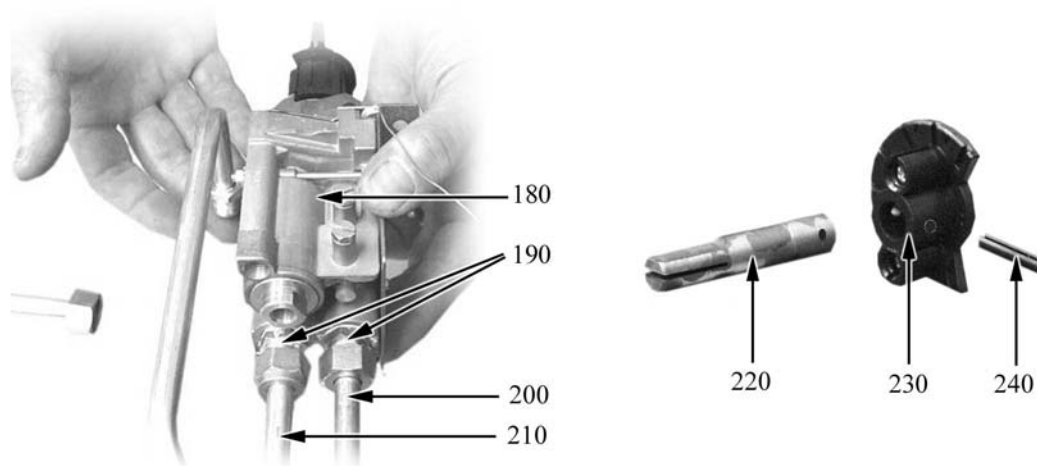

Spare parts

ID	Models	Type	Description	P-code
Module: Valve and safety thermostat				
180	VAL		Valve	8219950
190	VAL		Pipe fitting	822450170
200	VAL		Pipe	823560052
200	VAL		Pipe	823560471
210	VAL		Pipe	823560022
220	VAL		Knob binding	822160011
230	VAL		Flange	824710060
250	VAL		Pipe fitting	6A011608
260	VAL		Pipe	823560032
260	VAL		Pipe	823560481
100			Termocouple	6A011904
100	VAL		Termocouple	6A011909
280			Bushing	822120040
290			Nozzle set IT-DE	861310130
-			Nozzle BA 145	
-			Nozzle BA 130	
-			Nozzle BA 220	
-			Nozzle BA 220	
-			Nozzle BA 240	
-			Nozzle 19	
-			Nozzle 27	
-			Nozzle BA 145	
-			Nozzle BA 205	
-			Nozzle BA 230	
-			Nozzle 19	
-			Nozzle 27	
-			Nozzle 36	
-			Nozzle BA 145	

RUB= MODELS WITH TAP, VAL=MODELS WITH VALVE

9FT400=9FT/G400, 9FTT400=9FTT/G400, 9FTT405=9FTT/G405, 9FT410=9FT/G410, 9FTT410=9FTT/G410,
 9FTT415=9FTT/G415, 9FT800=9FT/G800, 9FTT800=9FTT/G800, 9FTT805=9FTT/G805, 9FT810=9FT/G810,
 9FTT810=9FTT/G810, 9FTT815=9FTT/G815, 9FT820=9FT/G820, 9FTT820=9FTT/G820, 9FTT825=9FTT/G825,
 9FTV400=9FTV/G400, 9FTTV400=9FTTV/G400, 9FTTV405=9FTTV/G405, 9FTV410=9FTV/G410,
 9FTTV410=9FTTV/G410, 9FTTV415= 9FTTV/G415, 9FTTV800=9FTTV/G800, 9FTTV805=9FTTV/G805,
 9FTV810=9FTV/G810, 9FTTV810= 9FTTV/G810, 9FTTV815=9FTTV/G815, 9FTV820=9FTV/G820,
 9FTTF800=9FTTF/G800, 9FTTFE800=9FTTF/GE800, 9FTTF820=9FTTF/G820, 9FTTFE820=9FTTF/GE820,
 9FTTFE805=9FTTF/GE805, 9FTTFE825=9FTTF/GE825

A=3/N/PE~400/230V 50Hz

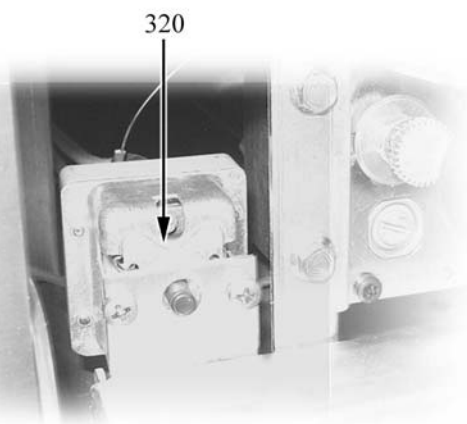
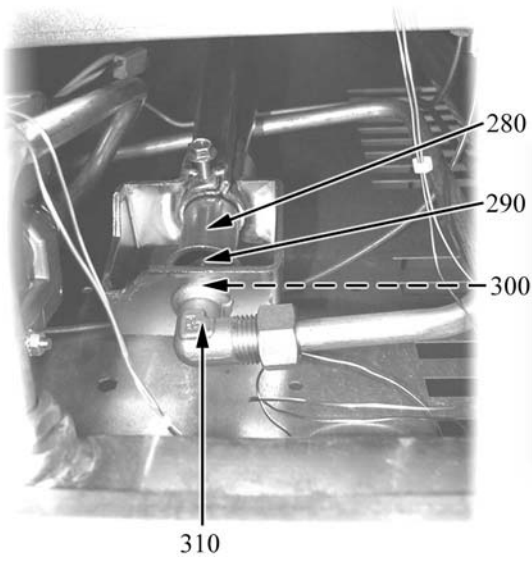
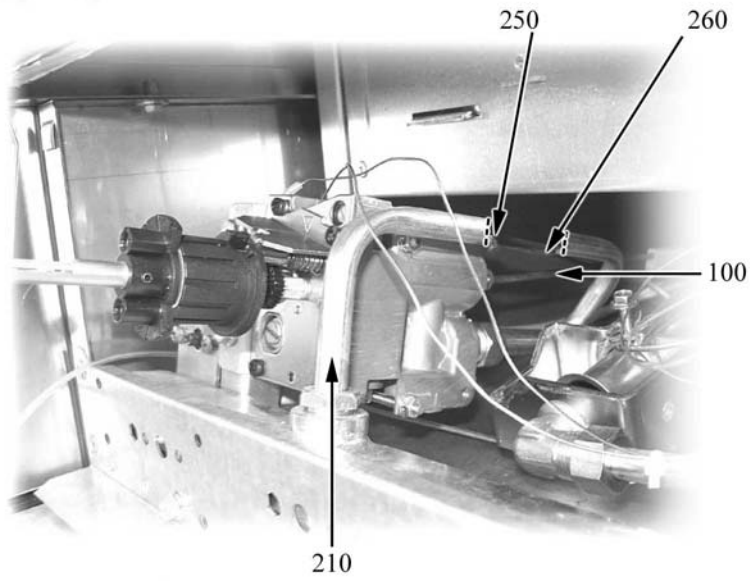
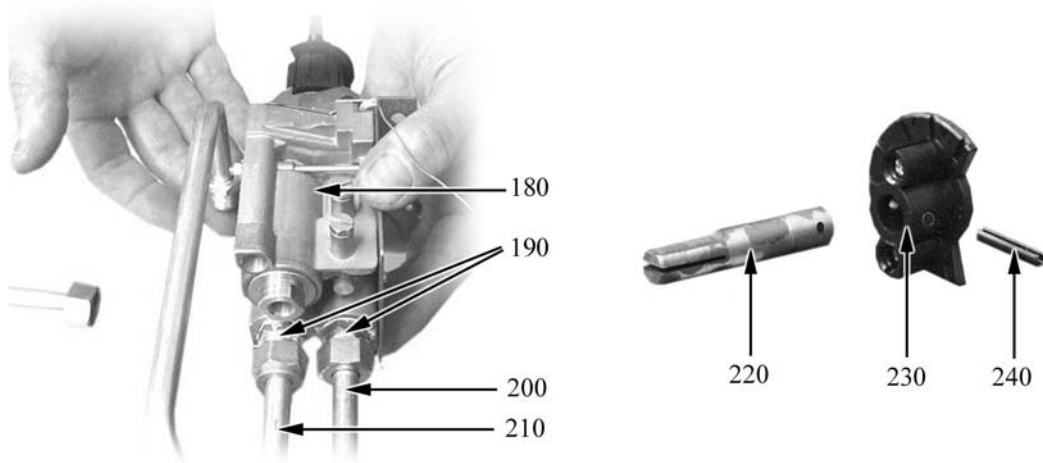

Spare parts

ID	Models	Type	Description	P-code
Module: Valvola e termostato di sicurezza				
-			Nozzle BA 220	
-			Nozzle BA 440	
-			Nozzle BA 400	
-			Nozzle 19	
-			Nozzle 27	
-			Nozzle 50	
300			Nut	822180010
310			Pipe fitting	822450010
320	VAL	9FTT400,9FTT405,9FTT410,9FTT415,9FTT800,9FTT805,9FTT810,9FTT815,9FTT820,9FTT825,9FTTV400,9FTTV405,9FTTV410,9FTTV415,9FTT800,9FTT805,9FTT810,9FTT815,9FTTV820,9FTTV820,9FTTF800,9FTTF800,9FTTF820,9FTTFE800,9FTTFE805,9FTTFE805,9FTTFE825	Safety Thermostat	826630010

RUB= MODELS WITH TAP, VAL=MODELS WITH VALVE

9FT400=9FT/G400, 9FTT400=9FTT/G400, 9FTT405=9FTT/G405, 9FT410=9FT/G410, 9FTT410=9FTT/G410, 9FTT415=9FTT/G415, 9FT800=9FT/G800, 9FTT800=9FTT/G800, 9FTT805=9FTT/G805, 9FT810=9FT/G810, 9FTT810=9FTT/G810, 9FTT815=9FTT/G815, 9FT820=9FT/G820, 9FTT820=9FTT/G820, 9FTT825=9FTT/G825, 9FTV400=9FTV/G400, 9FTTV400=9FTTV/G400, 9FTTV405=9FTTV/G405, 9FTV410=9FTV/G410, 9FTTV410=9FTTV/G410, 9FTTV415= 9FTTV/G415, 9FTTV800=9FTTV/G800, 9FTTV805=9FTTV/G805, 9FTV810=9FTV/G810, 9FTTV810= 9FTTV/G810, 9FTTV815=9FTTV/G815, 9FTV820=9FTV/G820, 9FTTF800=9FTTF/G800, 9FTTFE800=9FTTF/GE800, 9FTTF820=9FTTF/G820, 9FTTFE820=9FTTF/GE820, 9FTTFE805=9FTTF/GE805, 9FTTFE825=9FTTF/GE825

A=3/N/PE~400/230V 50Hz

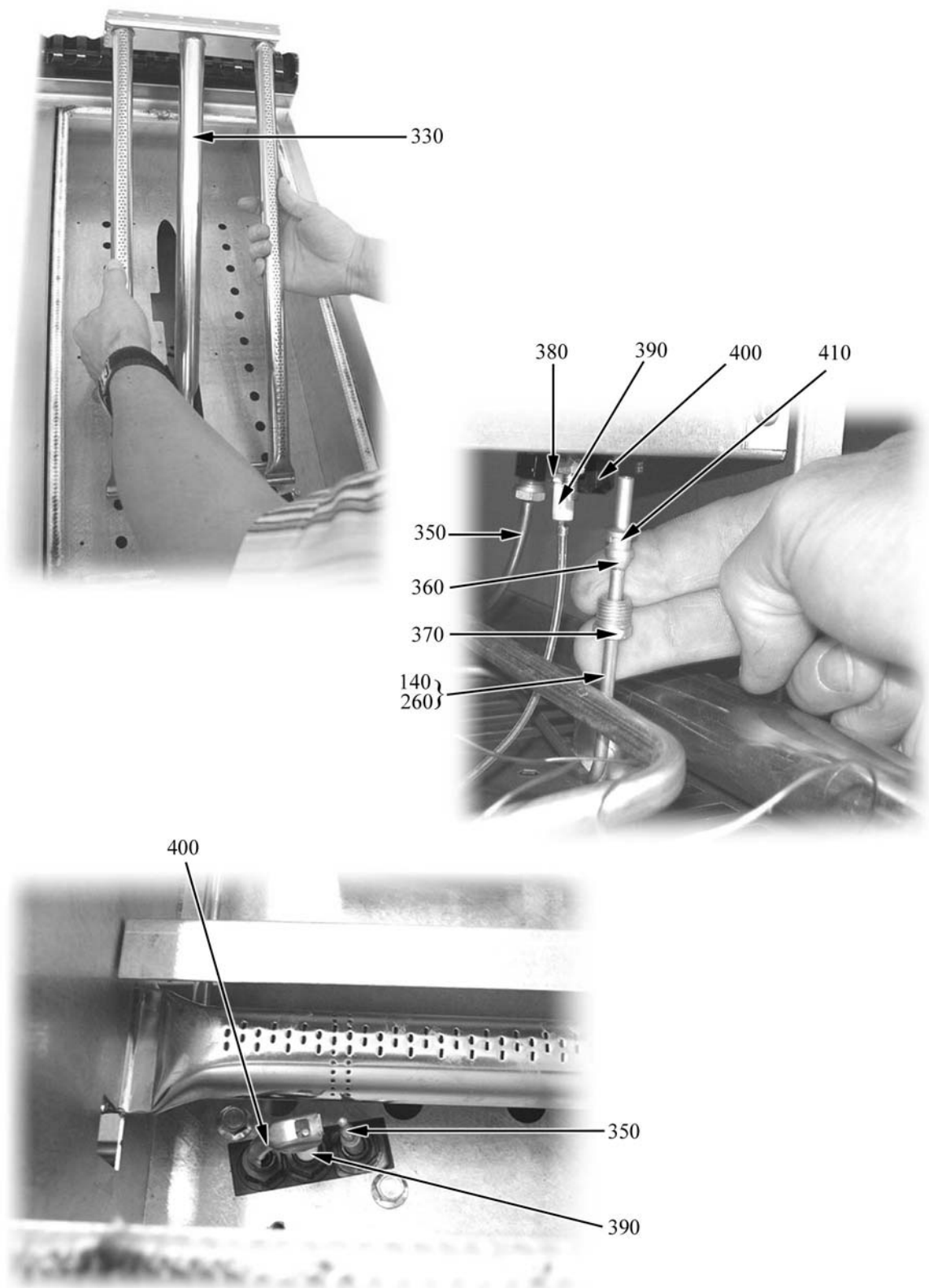

Spare parts

ID	Models	Type	Description	P-code
Module: Burner and pilot				
330			Burner	826390012
100			Termocouple	6A011904
360			Ogive	822450050
370			Pipe fitting	822450040
380			Pipe fitting	6A011707
390			Spark plug	6A013301
400			Pilot flame	826920030
410			Nozzle 27	6A013107
410			Nozzle 19	822140380
410			Nozzle 36	822140530
140	RUB		Pipe	823560230
260	VAL		Pipe	823560032
260	VAL		Pipe	823560481

RUB= MODELS WITH TAP, VAL=MODELS WITH VALVE

9FT400=9FT/G400, 9FTT400=9FTT/G400, 9FTT405=9FTT/G405, 9FT410=9FT/G410, 9FTT410=9FTT/G410,
 9FTT415=9FTT/G415, 9FT800=9FT/G800, 9FTT800=9FTT/G800, 9FTT805=9FTT/G805, 9FT810=9FT/G810,
 9FTT810=9FTT/G810, 9FTT815=9FTT/G815, 9FT820=9FT/G820, 9FTT820=9FTT/G820, 9FTT825=9FTT/G825,
 9FTV400=9FTV/G400, 9FTTV400=9FTTV/G400, 9FTTV405=9FTTV/G405, 9FTV410=9FTV/G410,
 9FTTV410=9FTTV/G410, 9FTTV415= 9FTTV/G415, 9FTTV800=9FTTV/G800, 9FTTV805=9FTTV/G805,
 9FTV810=9FTV/G810, 9FTTV810= 9FTTV/G810, 9FTTV815=9FTTV/G815, 9FTV820=9FTV/G820,
 9FTTF800=9FTTF/G800, 9FTTFE800=9FTTF/GE800, 9FTTF820=9FTTF/G820, 9FTTFE820=9FTTF/GE820,
 9FTTFE805=9FTTF/GE805, 9FTTFE825=9FTTF/GE825

A=3/N/PE~400/230V 50Hz

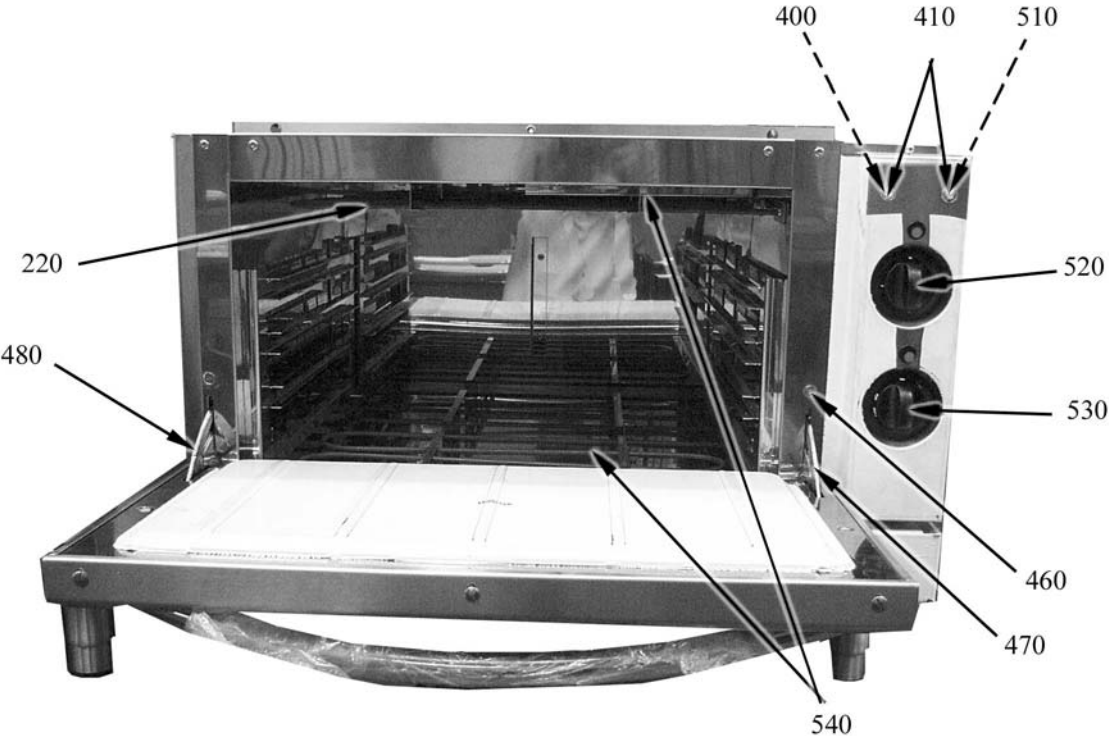

Spare parts

ID	Models	Type	Description	P-code
400		9FTTFE800,9FTTFE805, 9FTTFE820,9FTTFE825	Neon	826650050
410		9FTTFE800,9FTTFE805, 9FTTFE820,9FTTFE825	White neon lens	6A039207
510		9FTTFE800,9FTTFE805, 9FTTFE820,9FTTFE825	Black knob for gas	824710110
430		9FTTFE800,9FTTFE805, 9FTTFE820,9FTTFE825	Piezoelectric ignition	4.183E+10
440		9FTTFE800,9FTTFE805, 9FTTFE820,9FTTFE825	Washer	822160540
450		9FTTFE800,9FTTFE805, 9FTTFE820,9FTTFE825	Cap	826630420
460		9FTTFE800,9FTTFE805, 9FTTFE820,9FTTFE825	Higne roll-holder	6A035930
470		9FTTFE800,9FTTFE805, 9FTTFE820,9FTTFE825	Higne RH	6A035910
480		9FTTFE800,9FTTFE805, 9FTTFE820,9FTTFE825	Higne LH	6A035920
490		9FTTFE800,9FTTFE805, 9FTTFE820,9FTTFE825	Bottenplat	822420010
500		9FTTFE800,9FTTFE805, 9FTTFE820,9FTTFE825	Grid	826330020
510		9FTTFE800,9FTTFE805, 9FTTFE820,9FTTFE825	Green neon lens	6A038506
520		9FTTFE800,9FTTFE805, 9FTTFE820,9FTTFE825	Black switch knob for electric oven	824710710
530		9FTTFE800,9FTTFE805, 9FTTFE820,9FTTFE825	Black knob for electric oven	824710270
540		9FTTFE800,9FTTFE805, 9FTTFE820,9FTTFE825	Heating element 1500 W	826620041

RUB= MODELS WITH TAP VAL=MODELS WITH VALVE

9FT400=9FT/G400, 9FTT400=9FTT/G400, 9FTT405=9FTT/G405, 9FT410=9FT/G410, 9FTT410=9FTT/G410,
 9FTT415=9FTT/G415, 9FT800=9FT/G800, 9FTT800=9FTT/G800, 9FTT805=9FTT/G805, 9FT810=9FT/G810,
 9FTT810=9FTT/G810, 9FTT815=9FTT/G815, 9FT820=9FT/G820, 9FTT820=9FTT/G820, 9FTT825=9FTT/G825,
 9FTV400=9FTV/G400, 9FTTV400=9FTTV/G400, 9FTTV405=9FTTV/G405, 9FTV410=9FTV/G410,
 9FTTV410=9FTTV/G410, 9FTTV415= 9FTTV/G415, 9FTTV800=9FTTV/G800, 9FTTV805=9FTTV/G805,
 9FTV810=9FTV/G810, 9FTTV810= 9FTTV/G810, 9FTTV815=9FTTV/G815, 9FTV820=9FTV/G820,
 9FTTF800=9FTTF/G800, 9FTTFE800=9FTTF/GE800, 9FTTF820=9FTTF/G820, 9FTTFE820=9FTTF/GE820,
 9FTTFE805=9FTTF/GE805, 9FTTFE825=9FTTF/GE825

A=3/N/PE~400/230V 50Hz