

FRY-TOP A GAS Serie 700

MODELLO CON RUBINETTO

MODELLO CON VALVOLA

MODELLO CON FORNO

TIPO: 7FT/G400, 7FTT/G400, 7FT/G410, 7FTT/G410, 7FT/G800, 7FTT/G800, 7FT/G810, 7FTT/G810, 7FT/G820, 7FTT/G820, 7FTT/G405, 7FTT/G415, 7FTT/G805, 7FTT/G806, 7FTT/G815, 7FTT/G825, 7FTV/G400, 7FTT/G400, 7FTV/G410, 7FTTV/G410, 7FTV/G800, 7FTTV/G800, 7FTV/G810, 7FTTV/G810, 7FTV/G820, 7FTTV/G820, 7FTTV/G805, 7FTTV/G415, 7FTTV/G805, 7FTTV/G815, 7FTTV/G825, 7FTTF/G800, 7FTTF/GE800, 7FTTF/G820, 7FTTF/GE820, 7FTTF/G805, 7FTTF/GE805, 7FTTF/G825, 7FTTF/GE825

Ricambi



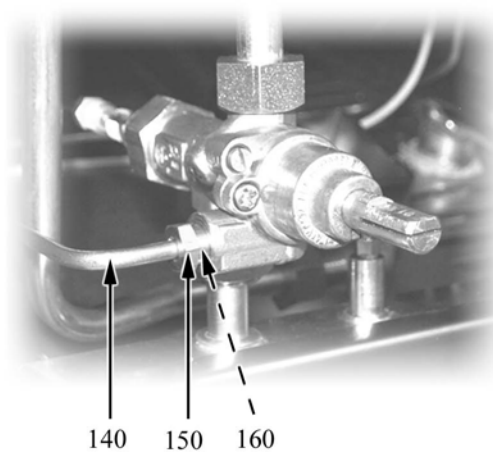
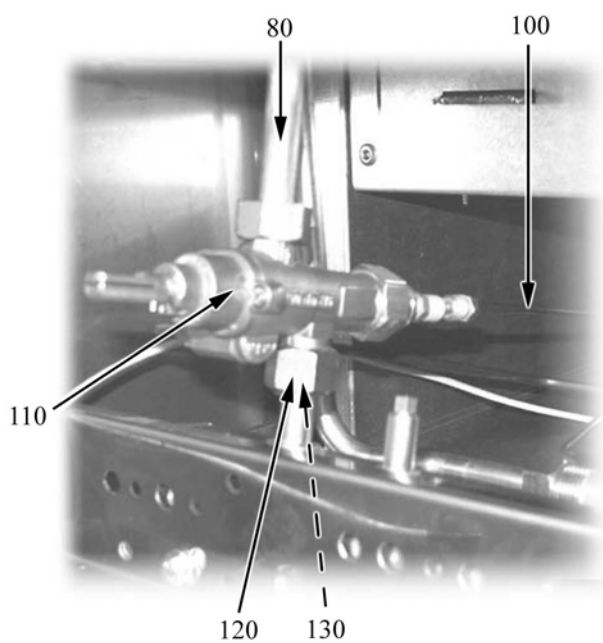
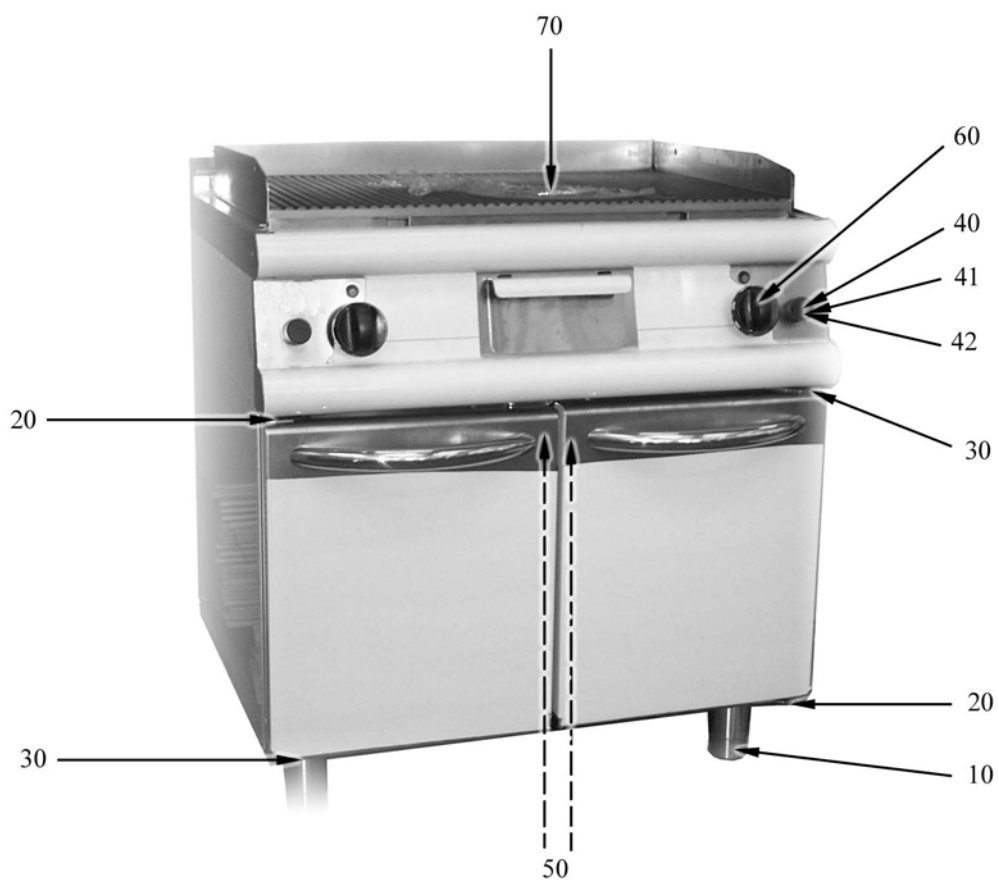

Parti di ricambio

ID	Modello	Tipo	Voltaggio	Descrizione	Codici del produttore
Module: Parti esterne e rubinetto					
10				Piedino	826490142
20				Cerniera inferiore sx/superiore dx porta	418S2547870
30				Cerniera inferiore dx/superiore sx porta	418S2547860
40				Accensione piezoelettrica	41826630020
41				Rondella	822160540
42				Cappuccio	826630420
50				Magnete	826900011
60	RUB			Manopola	824710100
60	VAL			Manopola	824710070
70		400G,400TG,400VG,400TVG		Piastra	826470180
70		410G,410TG,410VG,410TVG		Piastra	41826470210
70		800G,800TG,800VG,800TVG,800TFG,800TFGE		Piastra	41826470170
70		810G,810TG,810VG,810TVG		Piastra	41826470530
70		820G,820TG,820VG,820TVG,820TFG,820TFGE		Piastra	41826470220
70		405TG,405TVG		Piastra	41826470070
70		415TG,415TVG		Piastra	41826470550
70		805TG,805TVG,805TFG,805TFGE		Piastra	41826470060
70		815TG,815TVG		Piastra	41826470560
70		825TG,825TVG,825TFG,825TFGE		Piastra	41826470100
70		806TG		Piastra	41826471320
80	RUB	800G,810G,820G,800VG,810VG,820VG		Conduttura	823560511
80	RUB			Conduttura	823560213
100				Termocoppia	826920080
100	VAL	405TG,415TG,805TG,806TG,815TG,825TG,405TVG,415TVG,805TVG,815TVG,825TVG,805TFG,805TFGE,825TFG,825TFGE		Termocoppia	41826920180
110	RUB			Rubinetto	6A011490
120	RUB			Dado	6A011485
130	RUB			Bicono	6A011480
140	RUB	800G,810G,820G,800VG,810VG,820VG		Conduttura	41823560500

RUB= MODELLO CON RUBINETTO, VAL=MODELLO CON VALVOLA, FORNO=MODELLO CON FORNO

400G=7FT/G400, 400TG=7FTT/G400, 410G=7FT/G410, 410TG=7FTT/G410, 800G=7FT/G800, 800TG=7FTT/G800, 810G=7FT/G810, 810TG=7FTT/G810, 820G=7FT/G820, 820TG=7FTT/G820, 405TG=7FTT/G405, 415TG=7FTT/G415, 805TG=7FTT/G805, 806TG=7FTT/G806, 815TG=7FTT/G815, 825TG=7FTT/G825, 400VG=7FTV/G400, 400TVG=7FTT/G400, 410VG=7FTV/G410, 410TVG=7FTT/G410, 800VG=7FTV/G800, 800TVG=7FTT/G800, 810VG=7FTV/G810, 810TVG=7FTT/G810, 820VG=7FTV/G820, 820TVG=7FTT/G820, 405TVG=7FTT/G805, 415TVG=7FTT/G415, 805TVG=7FTT/G805, 815TVG=7FTT/G815, 825TVG=7FTT/G825, 800TFG=7FTT/G800, 800TFGE=7FTT/GE800, 820TFG=7FTT/G820, 820TFGE=7FTT/GE820, 805TFG=7FTT/G805, 805TFGE=7FTT/GE805, 825TFG=7FTT/G825, 825TFGE=7FTT/GE825

A=3/N/PE~400/230V 50Hz, H=3/PE~230V 50Hz

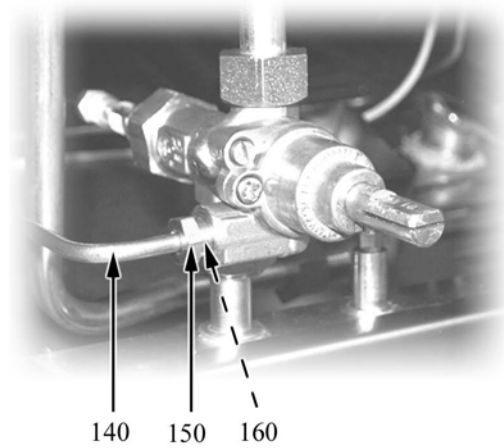
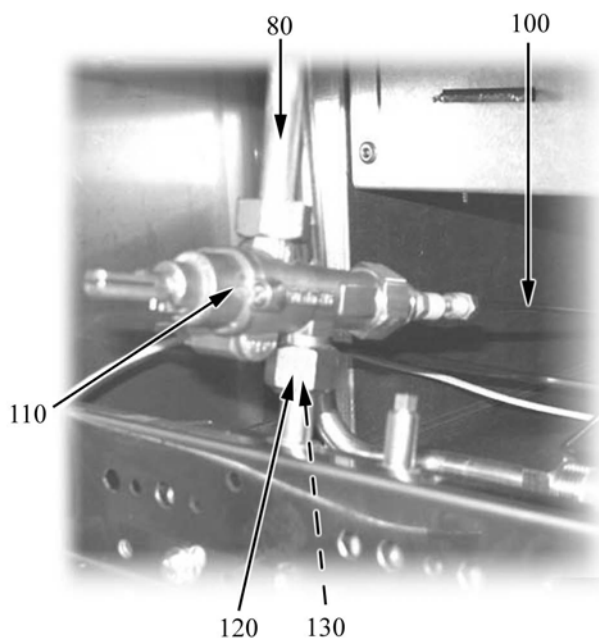
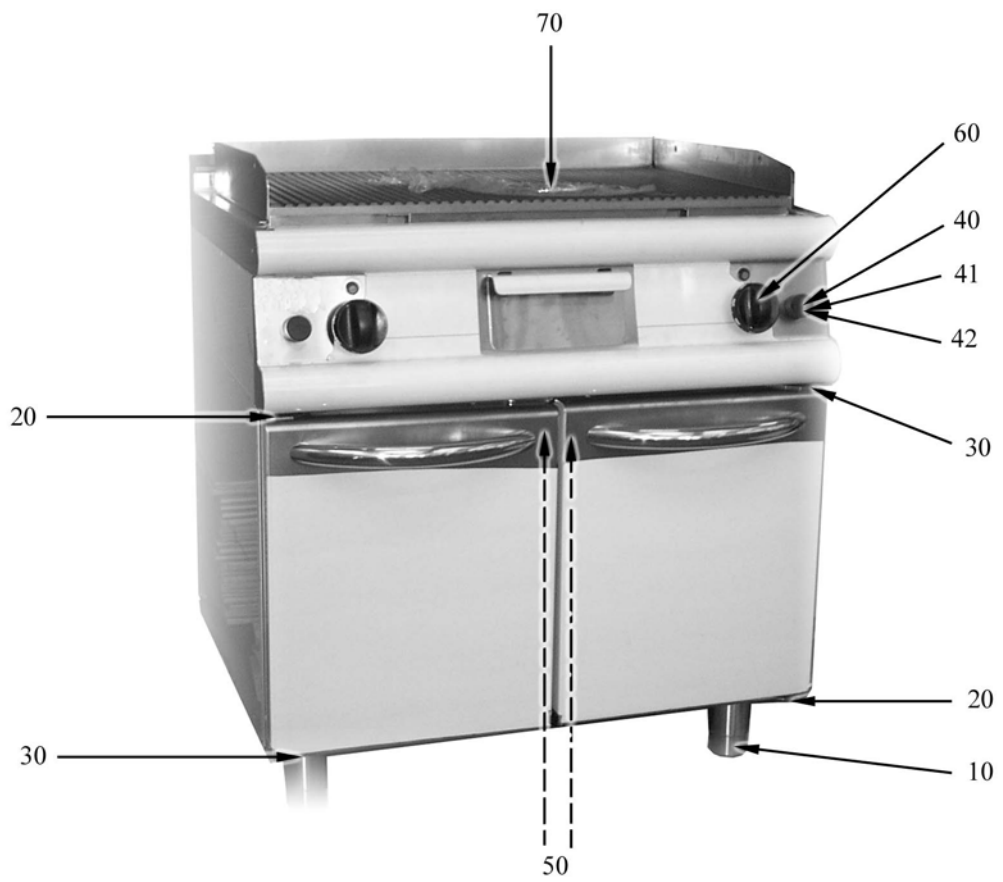

Parti di ricambio

ID	Modello	Tipo	Voltaggio	Descrizione	Codici del produttore
Module: Parti esterne e rubinetto					
140	RUB			Conduttura	41823560220
150	RUB			Dado	6A016110
160	RUB			Bicono	6A016120

RUB= MODELLO CON RUBINETTO, VAL=MODELLO CON VALVOLA, FORNO=MODELLO CON FORNO
 400G=7FT/G400, 400TG=7FTT/G400, 410G=7FT/G410, 410TG=7FTT/G410, 800G=7FT/G800, 800TG=7FTT/G800,
 810G=7FT/G810, 810TG=7FTT/G810, 820G=7FT/G820, 820TG=7FTT/G820, 405TG=7FTT/G405, 415TG=7FTT/G415,
 805TG=7FTT/G805, 806TG=7FTT/G806, 815TG=7FTT/G815, 825TG=7FTT/G825, 400VG=7FTV/G400,
 400TVG=7FTT/G400, 410VG=7FTV/G410, 410TVG=7FTTV/G410, 800VG=7FTV/G800, 800TVG=7FTTV/G800,
 810VG=7FTV/G810, 810TVG=7FTTV/G810, 820VG=7FTV/G820, 820TVG=7FTTV/G820, 405TVG=7FTTV/G805,
 415TVG= 7FTTV/G415, 805TVG=7FTTV/G805, 815TVG=7FTTV/G815, 825TVG=7FTTV/G825, 800TFG=7FTTF/
 G800, 800TFGE=7FTTF/GE800, 820TFG=7FTTF/G820, 820TFGE=7FTTF/GE820, 805TFG=7FTTF/G805,
 805TFGE=7FTTF/GE805, 825TFG=7FTTF/G825, 825TFGE=7FTTF/GE825

A=3/N/PE~400/230V 50Hz, H=3/PE~230V 50Hz

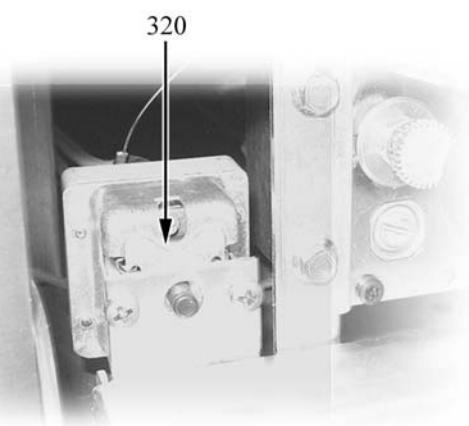
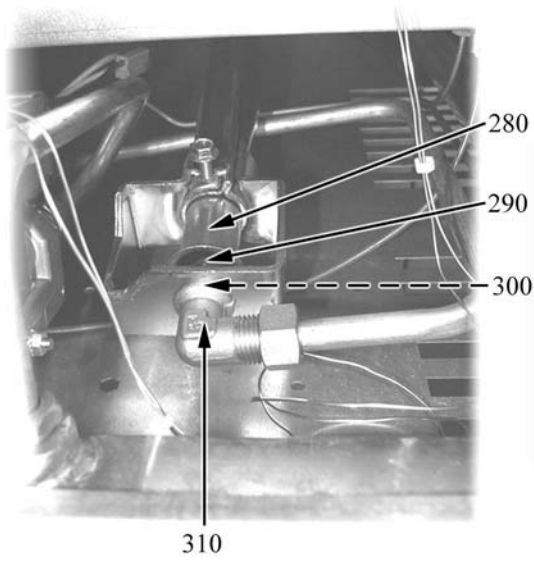
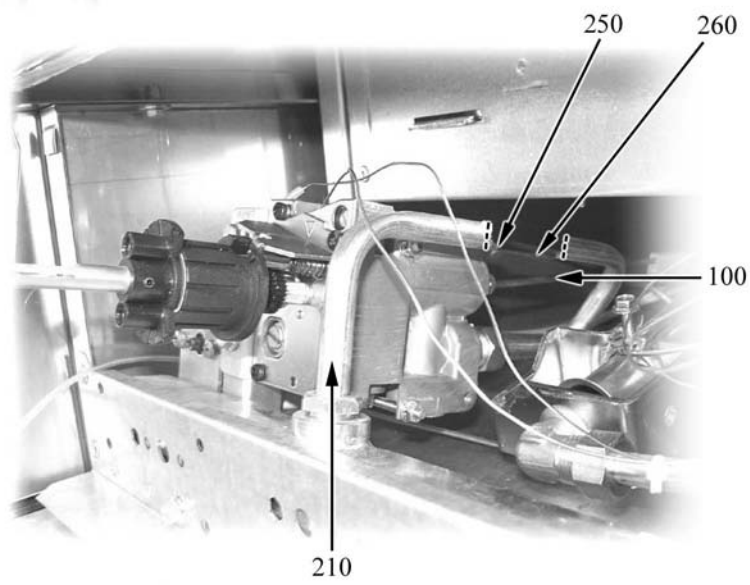
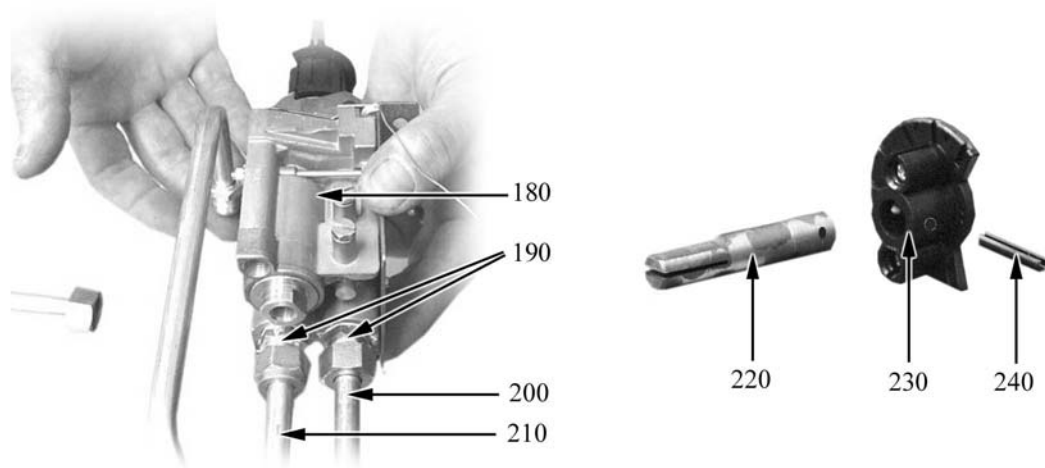

Parti di ricambio

ID	Modello	Tipo	Voltaggio	Descrizione	Codici del produttore
Module:Valvola e termostato di sicurezza					
180	VAL			Valvola	41826920012
190	VAL			Raccordo	41822450170
200	VAL			Conduttura	41823560052
200	VAL	800TG,810TG,820TG,805TG,806TG,815TG,825TG,800TVG,810TVG,820TVG,805TVG,815TVG,825TVG		Conduttura	41823560471
210	VAL			Conduttura	41823560022
220	VAL			Attacco manopola	41822160011
230	VAL			Flangia	41824710060
240	VAL			Spina elastica	418227993140
250	VAL			Raccordo bicono	41822450060
260	VAL			Conduttura	41823560401
260	VAL	800TG,810TG,820TG,805TG,806TG,815TG,825TG,800TVG,810TVG,820TVG,805TVG,815TVG,825TVG		Conduttura	41823560041
100				Termocoppia	41826920080
100	VAL	405TG,415TG,805TG,806TG,815TG,825TG,405TVG,415TVG,805TVG,815TVG,825TVG,805TFG,805TFGE,825TFG,825TFGE		Termocoppia	41826920180
280				Boccola	41822120030
290				Ugello L 110	41822140010
290				Ugello L 125	41822140020
290				Ugello L 190	41822140050
290				Ugello L 210	41822140060
300				Dado	41822180010
310				Raccordo	41822450010
320	VAL	405TG,415TG,805TG,806TG,815TG,825TG,405TVG,415TVG,805TVG,815TVG,825TVG		Termostato sicurezza	41826630010

RUB= MODELLO CON RUBINETTO, VAL=MODELLO CON VALVOLA, FORNO=MODELLO CON FORNO
 400G=7FT/G400, 400TG=7FTT/G400, 410G=7FT/G410, 410TG=7FTT/G410, 800G=7FT/G800, 800TG=7FTT/G800,
 810G=7FT/G810, 810TG=7FTT/G810, 820G=7FT/G820, 820TG=7FTT/G820, 405TG=7FTT/G405, 415TG=7FTT/G415,
 805TG=7FTT/G805, 806TG=7FTT/G806, 815TG=7FTT/G815, 825TG=7FTT/G825, 400VG=7FTV/G400,
 400TVG=7FTT/G400, 410VG=7FTV/G410, 410TVG=7FTT/G410, 800VG=7FTV/G800, 800TVG=7FTT/G800,
 810VG=7FTV/G810, 810TVG=7FTT/G810, 820VG=7FTV/G820, 820TVG=7FTT/G820, 405TVG=7FTT/G805,
 415TVG=7FTT/G415, 805TVG=7FTT/G805, 815TVG=7FTT/G815, 825TVG=7FTT/G825, 800TFG=7FTT/G800,
 800TFGE=7FTT/GE800, 820TFG=7FTT/G820, 820TFGE=7FTT/GE820, 805TFG=7FTT/G805,
 805TFGE=7FTT/GE805, 825TFG=7FTT/G825, 825TFGE=7FTT/GE825

A=3/N/PE~400/230V 50Hz, H=3/PE~230V 50Hz

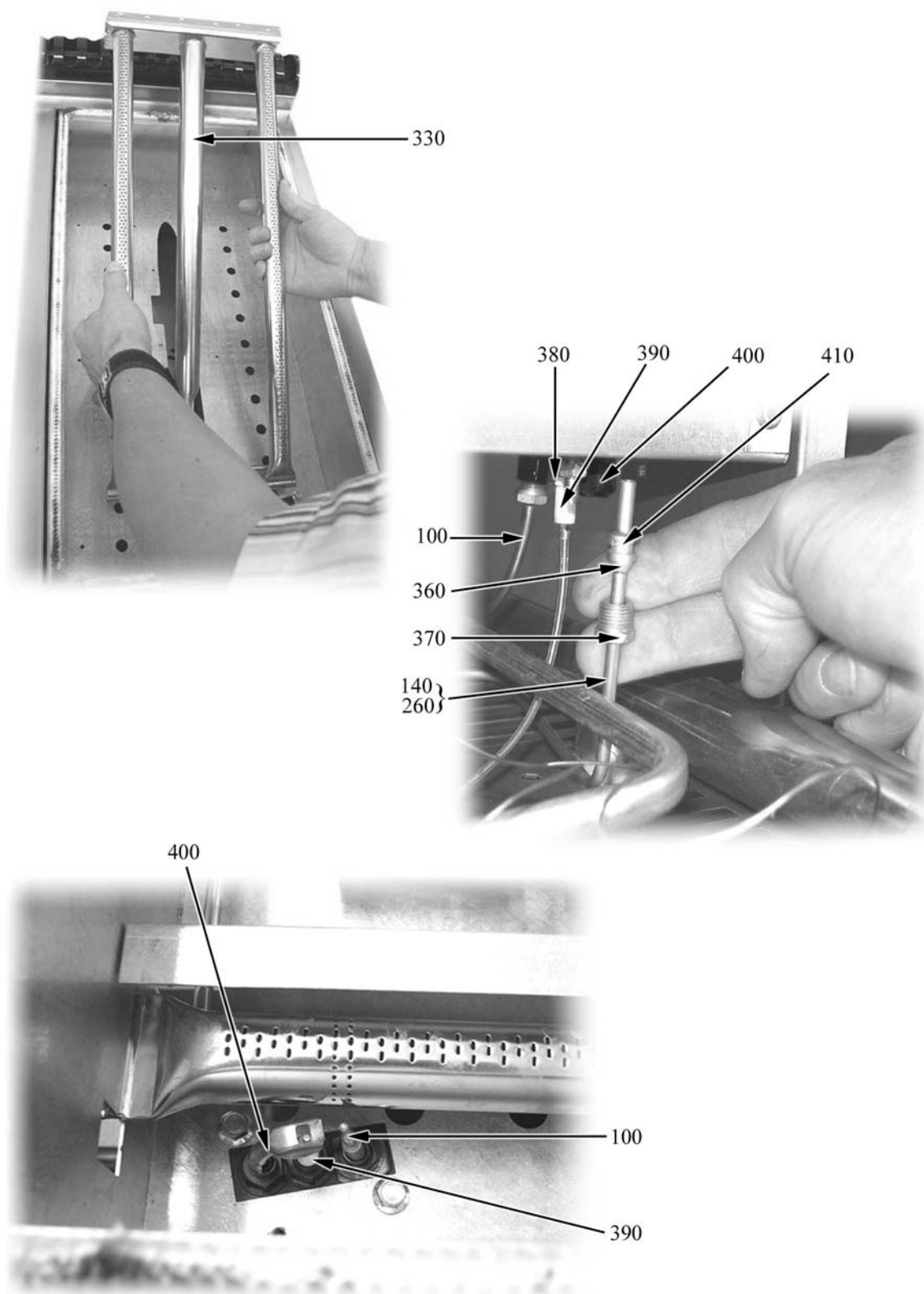

Parti di ricambio

ID	Modello	Tipo	Voltaggio	Descrizione	Codici del produttore
Module:Bruciatore e pilota					
330				Bruciatore	41826390023
100				Termocoppia	41826920080
100	VAL	405TG,415TG,805TG,806TG,815TG,825TG,405TVG,415TVG,805TVG,815TVG,825TVG,805TFG,805TFGE,825TFG,825TFGE		Termocoppia	41826920180
360				Bicono	41822450050
370				Raccordo	41822450040
380				Raccordo	41822450070
390				Candela	41826650010
400				Pilota	41826920030
410				Ugello 19	822140380
410				Ugello 27	6A013107
140	RUB			Conduttura	41823560220
140	RUB	800G,810G,820G,800VG,810VG,820VG		Conduttura	41823560500
260	VAL			Conduttura	41823560041
260	VAL	800TG,810TG,820TG,805TG,806TG,815TG,825TG,800TVG,810TVG,820TVG,805TVG,815TVG,825TVG		Conduttura	41823560401

RUB= MODELLO CON RUBINETTO, VAL=MODELLO CON VALVOLA, FORNO=MODELLO CON FORNO
 400G=7FT/G400, 400TG=7FTT/G400, 410G=7FT/G410, 410TG=7FTT/G410, 800G=7FT/G800, 800TG=7FTT/G800,
 810G=7FT/G810, 810TG=7FTT/G810, 820G=7FT/G820, 820TG=7FTT/G820, 405TG=7FTT/G405, 415TG=7FTT/G415,
 805TG=7FTT/G805, 806TG=7FTT/G806, 815TG=7FTT/G815, 825TG=7FTT/G825, 400VG=7FTV/G400,
 400TVG=7FTT/G400, 410VG=7FTV/G410, 410TVG=7FTTV/G410, 800VG=7FTV/G800, 800TVG=7FTTV/G800,
 810VG=7FTV/G810, 810TVG=7FTTV/G810, 820VG=7FTV/G820, 820TVG=7FTTV/G820, 405TVG=7FTTV/G805,
 415TVG=7FTTV/G415, 805TVG=7FTTV/G805, 815TVG=7FTTV/G815, 825TVG=7FTTV/G825, 800TFG=7FTTF/
 G800, 800TFGE=7FTTF/GE800, 820TFG=7FTTF/G820, 820TFGE=7FTTF/GE820, 805TFG=7FTTF/G805,
 805TFGE=7FTTF/GE805, 825TFG=7FTTF/G825, 825TFGE=7FTTF/GE825

A=3/N/PE~400/230V 50Hz, H=3/PE~230V 50Hz

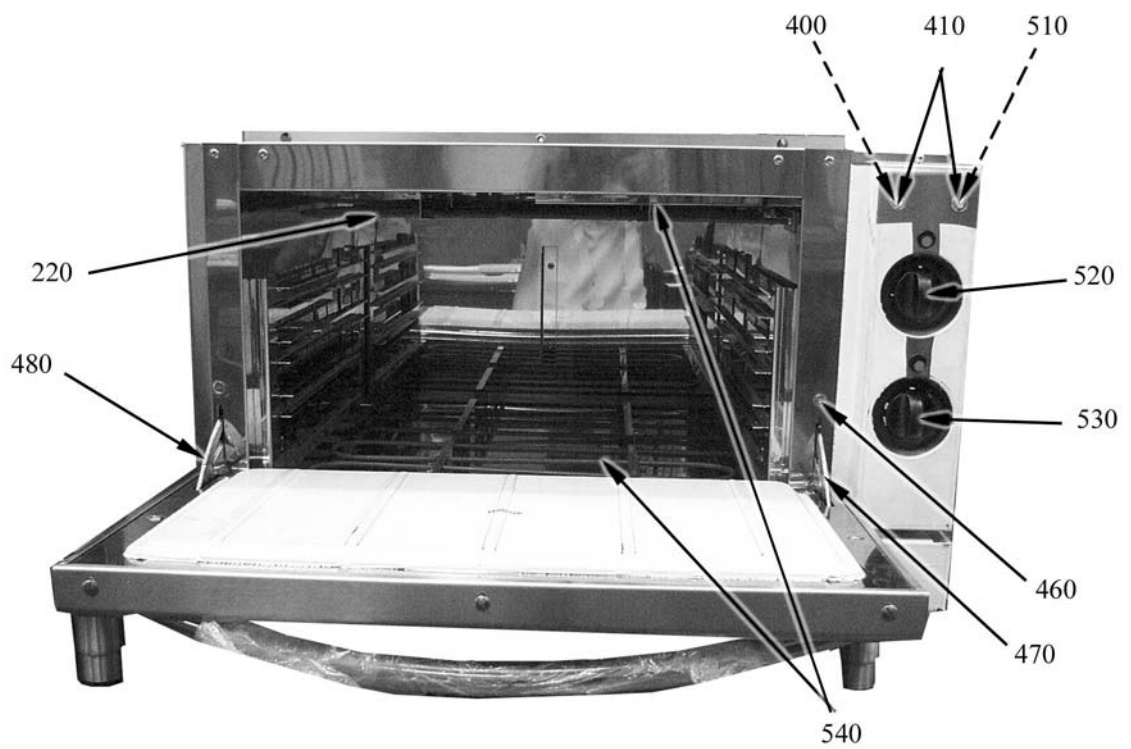

Parti di ricambio

ID	Modello	Tipo	Voltaggio	Descrizione	Codici del produttore
Module: Parti esterne forno gas ed elettrico					
400	FORNO	800TFGE,820TFGE,805TFGE,825TFGE		Segnalatore luminoso verde	826650050
410	FORNO	800TFGE,820TFGE,805TFGE,825TFGE		Gemma bianca	6A039207
420	FORNO	800TFG,820TFG,805TFG,825TFG		Manopola nera per forno	824710110
430	FORNO	800TFG,820TFG,805TFG,825TFG		Accensione piezoelettrica	41826630020
440	FORNO	800TFG,820TFG,805TFG,825TFG		Rondella	822160540
450	FORNO	800TFG,820TFG,805TFG,825TFG		Cappuccio	826630420
460	FORNO			Portarullini per cerniera	6A035930
470	FORNO			Cerniera dx	6A035910
480	FORNO			Cerniera sx	6A035920
490	FORNO			Suola forno	41821410191
500	FORNO			Griglia	41826330030
510	FORNO	800TFGE,820TFGE,805TFGE,825TFGE		Segnalatore luminoso arancio	6A038506
520	FORNO	800TFGE,820TFGE,805TFGE,825TFGE		Manopola commutatore forno elettrico	824710710
530	FORNO	800TFGE,820TFGE,805TFGE,825TFGE		Manopola forno elettrico nera	824710270
540	FORNO	800TFGE,820TFGE,805TFGE,825TFGE		Resistenza 1500 W	826620041

RUB= MODELLO CON RUBINETTO, VAL=MODELLO CON VALVOLA, FORNO=MODELLO CON FORNO
 400G=7FT/G400, 400TG=7FTT/G400, 410G=7FT/G410, 410TG=7FTT/G410, 800G=7FT/G800, 800TG=7FTT/G800,
 810G=7FT/G810, 810TG=7FTT/G810, 820G=7FT/G820, 820TG=7FTT/G820, 405TG=7FTT/G405, 415TG=7FTT/G415,
 805TG=7FTT/G805, 806TG=7FTT/G806, 815TG=7FTT/G815, 825TG=7FTT/G825, 400VG=7FTV/G400,
 400TVG=7FTT/G400, 410VG=7FTV/G410, 410TVG=7FTT/G410, 800VG=7FTV/G800, 800TVG=7FTT/G800,
 810VG=7FTV/G810, 810TVG=7FTT/G810, 820VG=7FTV/G820, 820TVG=7FTT/G820, 405TVG=7FTT/G805,
 415TVG=7FTT/G415, 805TVG=7FTT/G805, 815TVG=7FTT/G815, 825TVG=7FTT/G825, 800TFG=7FTT/G800,
 800TFGE=7FTT/GE800, 820TFG=7FTT/G820, 820TFGE=7FTT/GE820, 805TFG=7FTT/G805,
 805TFGE=7FTT/GE805, 825TFG=7FTT/G825, 825TFGE=7FTT/GE825

A=3/N/PE~400/230V 50Hz, H=3/PE~230V 50Hz

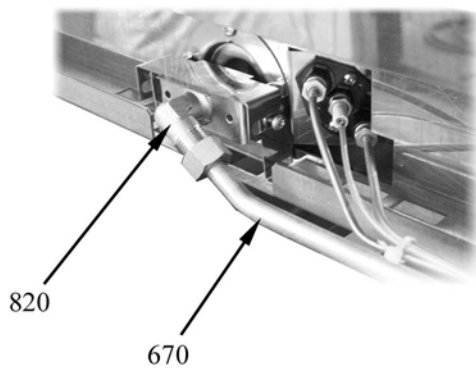
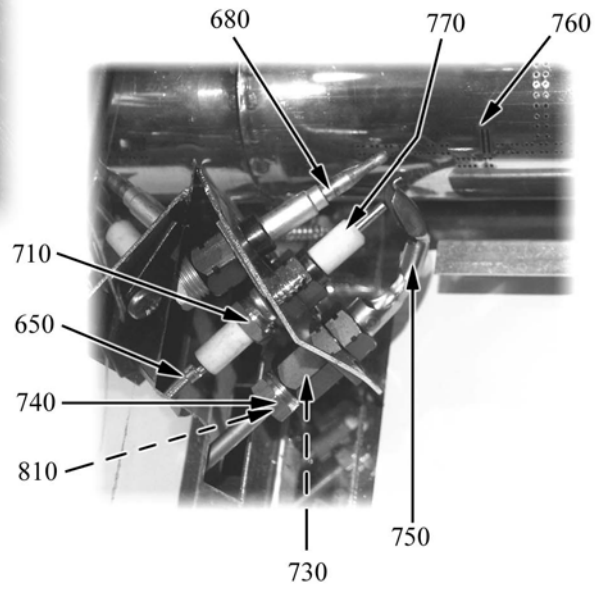
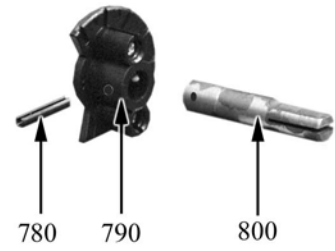
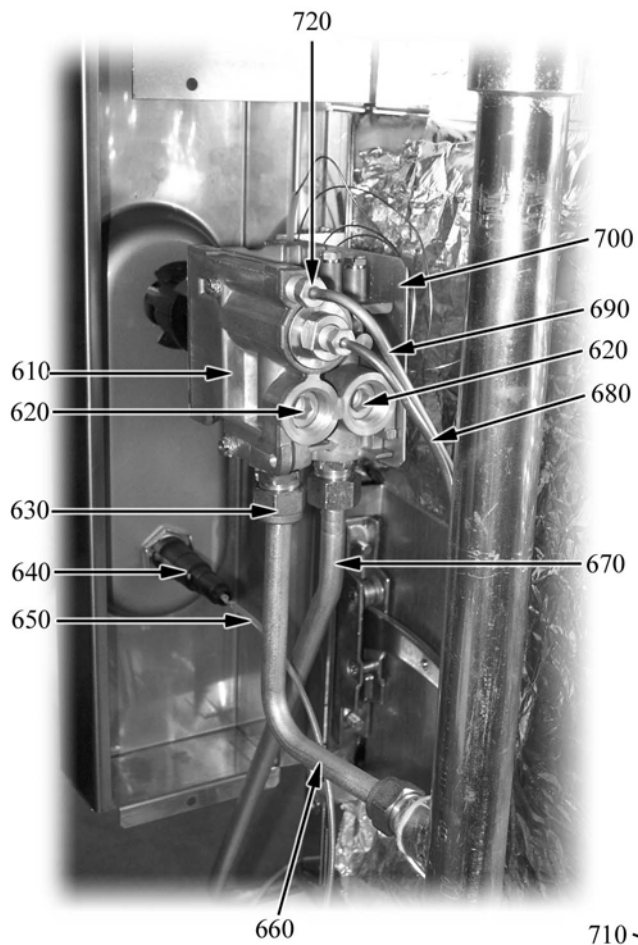

Parti di ricambio

ID	Modello	Tipo	Voltaggio	Descrizione	Codici del produttore
Module: Componenti forno a gas (valvola, regolazione aria, bruciatore)					
610	FORNO	800TFG,820TFG,805TFG,825TFG		Valvola	826920012
620	FORNO	800TFG,820TFG,805TFG,825TFG		Tappo	8219951
630	FORNO	800TFG,820TFG,805TFG,825TFG		Raccordo	822450170
640	FORNO	800TFG,820TFG,805TFG,825TFG		Accensione piezoelettrica	41826630020
650	FORNO	800TFG,820TFG,805TFG,825TFG		Cavo d'accensione	2510698
660	FORNO	800TFG,820TFG,805TFG,825TFG		Conduttura Valvola/Rampa	2514615
670	FORNO	800TFG,820TFG,805TFG,825TFG		Conduttura Valvola/Bruciatore forno	823560060
680	FORNO	800TFG,820TFG,805TFG,825TFG		Termocoppia	826920080
690	FORNO	800TFG,820TFG,805TFG,825TFG		Conduttura Valvola/Pilota forno	823560070
700	FORNO	800TFG,820TFG,805TFG,825TFG		Squadretta	418S2547780
710	FORNO	800TFG,820TFG,805TFG,825TFG		Raccordo	6A011707
720	FORNO	800TFG,820TFG,805TFG,825TFG		Raccordo bicono	6A011608
730	FORNO	800TFG,820TFG,805TFG,825TFG		Ugello 19	822140380
730	FORNO	800TFG,820TFG,805TFG,825TFG		Ugello 27	6A013107
740	FORNO	800TFG,820TFG,805TFG,825TFG		Raccordo	822450040
750	FORNO	800TFG,820TFG,805TFG,825TFG		Pilota	826920070
760	FORNO	800TFG,820TFG,805TFG,825TFG		Bruciatore	41826390050
770	FORNO	800TFG,820TFG,805TFG,825TFG		Candela	6A013301
780	FORNO	800TFG,820TFG,805TFG,825TFG		Spina elastica	418227993140
790	FORNO	800TFG,820TFG,805TFG,825TFG		Flangia	2518660
800	FORNO	800TFG,820TFG,805TFG,825TFG		Attacco manopola	2518650
810	FORNO	800TFG,820TFG,805TFG,825TFG		Bicono	822450050
820	FORNO	800TFG,820TFG,805TFG,825TFG		Raccordo	822450010

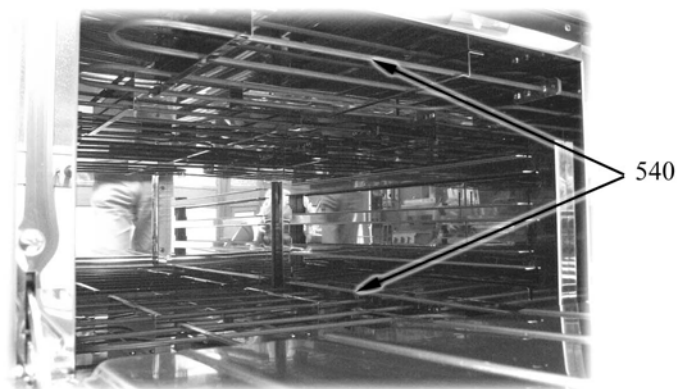
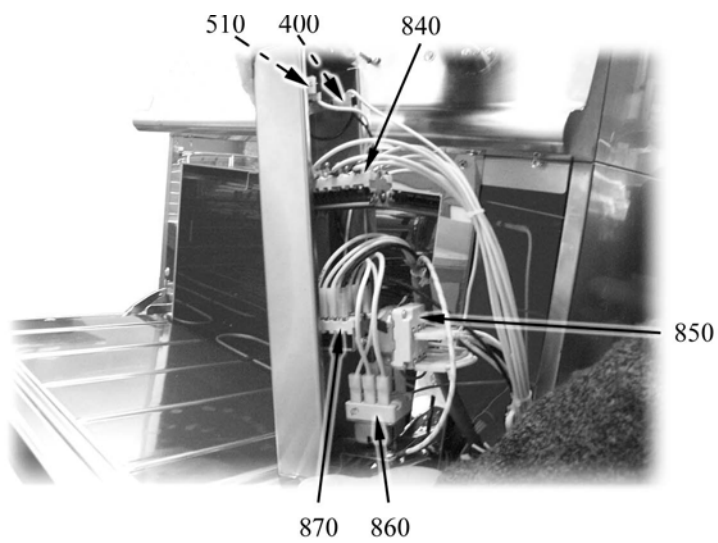

Parti di ricambio

ID	Modello	Tipo	Voltaggio	Descrizione	Codici del produttore
Module: Componenti forno elettrico					
400	FORNO	800TFGE,820TFGE,805TFGE,825TFGE		Segnalatore luminoso verde	826650050
510	FORNO	800TFGE,820TFGE,805TFGE,825TFGE		Segnalatore luminoso arancio	6A038506
540	FORNO	800TFGE,820TFGE,805TFGE,825TFGE		Resistenza 1500 W	826620041
840	FORNO	800TFGE,820TFGE,805TFGE,825TFGE		Commutatore	6A046750

RUB= MODELLO CON RUBINETTO, VAL=MODELLO CON VALVOLA, FORNO=MODELLO CON FORNO

400G=7FT/G400, 400TG=7FTT/G400, 410G=7FT/G410, 410TG=7FTT/G410, 800G=7FT/G800, 800TG=7FTT/G800, 810G=7FT/G810, 810TG=7FTT/G810, 820G=7FT/G820, 820TG=7FTT/G820, 405TG=7FTT/G405, 415TG=7FTT/G415, 805TG=7FTT/G805, 806TG=7FTT/G806, 815TG=7FTT/G815, 825TG=7FTT/G825, 400VG=7FTV/G400, 400TVG=7FTT/G400, 410VG=7FTV/G410, 410TVG=7FTTV/G410, 800VG=7FTV/G800, 800TVG=7FTTV/G800, 810VG=7FTV/G810, 810TVG=7FTTV/G810, 820VG=7FTV/G820, 820TVG=7FTTV/G820, 405TVG=7FTTV/G805, 415TVG=7FTTV/G415, 805TVG=7FTTV/G805, 815TVG=7FTTV/G815, 825TVG=7FTTV/G825, 800TFG=7FTTF/G800, 800TFGE=7FTTF/GE800, 820TFG=7FTTF/G820, 820TFGE=7FTTF/GE820, 805TFG=7FTTF/G805, 805TFGE=7FTTF/GE805, 825TFG=7FTTF/G825, 825TFGE=7FTTF/GE825

A=3/N/PE~400/230V 50Hz, H=3/PE~230V 50Hz