

ATTENZIONE: PER TENSIONI SPECIALI, SPECIFICARE SEMPRE IL MODELLO DI FORNO ED IL NUMERO DI MATRICOLA
ATTENTION: FOR SPECIAL VOLTAGES, PLEASE ALWAYS SPECIFY THE OVEN MODEL AND THE SERIAL NUMBER

ATTENTION: POUR TENSIONS SPÉCIALES, MERCI DE SPÉCIFIER TOUJOURS LE MODÈLE DU FOUR ET LE NUMÉRO DE SÉRIE
ACHTUNG: BEI SONDRSPANNUNGEN, BITTE IMMER OFEN-MODELL UND SERIENNUMMER GEBEN.

ed. 0713

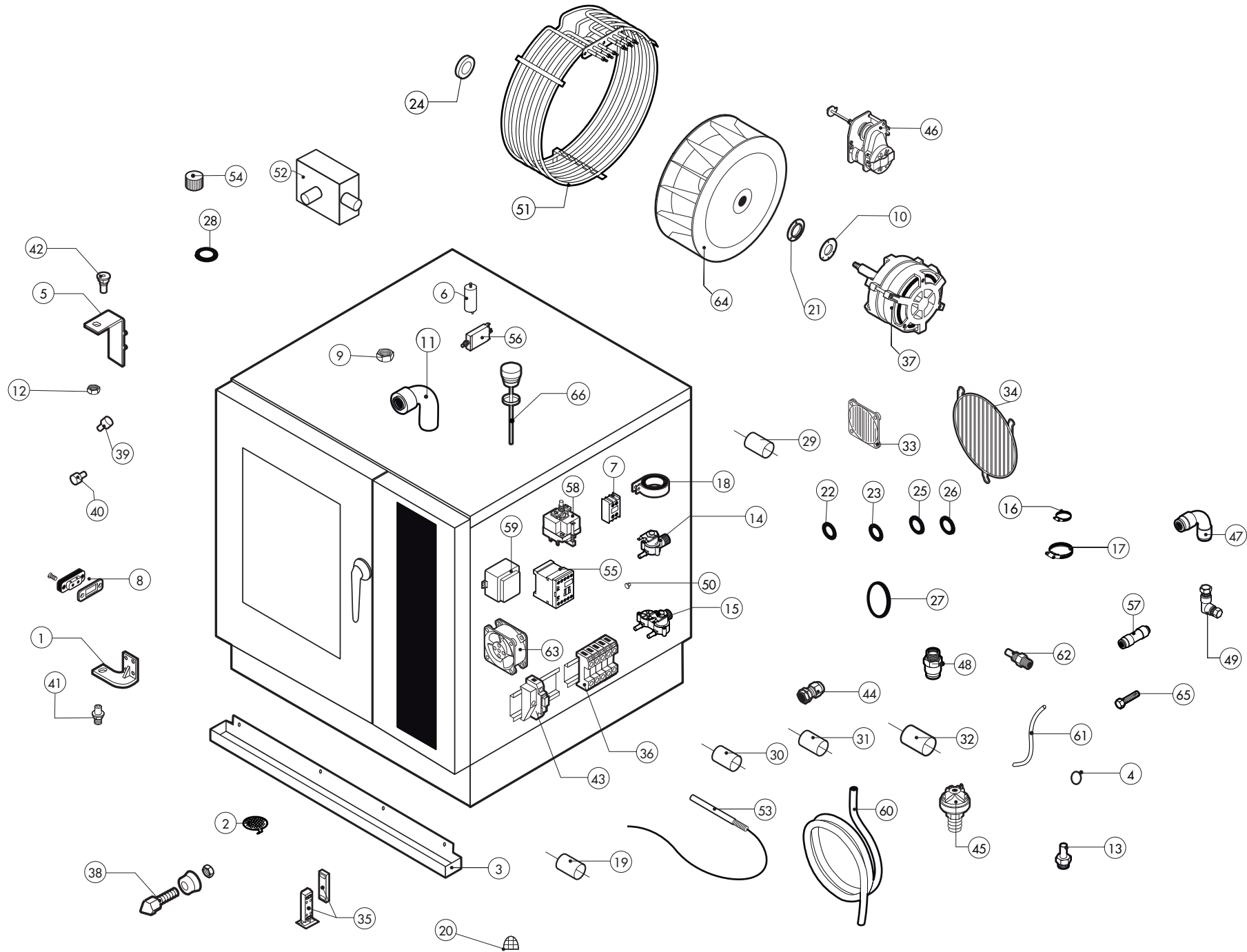

ATTENZIONE: PER ORDINARE I RICAMBI, SPECIFICARE SEMPRE IL MODELLO DI FORNO ED IL NUMERO DI MATRICOLA
ATTENTION: WHEN ORDERING SPARE PARTS, PLEASE ALWAYS SPECIFY THE OVEN MODEL AND THE SERIAL NUMBER

ATTENTION: POUR COMMANDER DES PIÈCES, MERCI DE SPECIFIER TOUJOURS LE MODÈLE DU FOUR ET LE NUMÉRO DE SÉRIE
ACHTUNG: UM ERSATZTEILE ZU BESTELLEN, BITTE IMMER OFEN-MODELL UND SERIENNUMMER GEBEN.

ed. 0713

POS.	COD.	Pz.	DESCRIZIONE	DESCRIPTION	DESCRIPTION	BESCHREIBUNG	DESCRIPCIÓN
1	R11207240	1	ASS.CERNIERA INF. M-V/061-101-102 2005	LOWER DOOR HINGE	CHARNIERE INFERIEURE PORTE	UNTERES SCHARNIER	BISAGRA INFERIOR
2	R10201700	1	ASS.FILTRO DI SCARICO D.76/44.5 M/106-11	DRAIN FILTER	FILTRE ENCEINTE	ABFLUSSFILTER	FILTRO DESAGUE
3	R69180190	1	BACINELLA SCARICO G/M-V/T06-T10	DRIP TRAY	PLATEAU D'ÉGOUTTEMENT	WASSERTROPFTASSE	BANDEJA DEL GOTEÓ
4	R62070023	1	BICONO PILOTA TUBO D.6 905.	BICONE D.6	BICONE D. 6	KEGEL D.6	BICONO D.6
5	R11426830	1	CERNIERA SUPER.PORTA SR.2013	UPPER DOOR HINGE	CHARNIERE SUPERIEURE PORTE	OBERES SCHARNIER	BISAGRA SUPERIOR
6	R65190180	1	CONDENSATORE 10MF/450V	CAPACITOR	CONDENSATEUR	KONDENSATOR	CONDENSADOR
7	R65140730	1	CONT.AUS.1L+1R DILM32-XH11 4-7,5KW MOE.	AUX.CONTACT 1L+1R	CONTACT AUXILIAIRE 1L+1R	ZUSÄTZLICHER KONTAKT 1L+1R	CONTACTO AUXILIAR 1L+1R
8	R65260750	1	CONTATTO PER LUCI SR.2000	LAMPS CONTACT BLOCK	CONTACT ECLAIRAGE	LICHTKONTSCHALTER	CONTACTO PARA LUZ
9	R65240040	1	CONTRODADO PER RACCORDO 107 Z/29	CABLE GLAND LOCK NUT	CONTRE-ECROU POUR RONDELLE FIXATION	MUTTER	CONTRODADO PASACABLE
10	R58003870	1	CONTROFLANGIA GUARN.PICCOLA	MOTOR GASKET BRASS COUNTER FLANGE	CONTRE- BRIDE JOINT MOTEUR	GEGENFLANSCH F. MOTORDICHTUNG	CONTRABRIDA JUNTA MOTOR
11	R62280038	1	CURVA C/MORSET.HTS-HTSW X TUBO D.50 D.50X	CURVE WITH TERMINAL	COURBE AVEC BORNIER	KURVE MIT KLEMM	CURVA CON REGLETERA
12	R58004050	2	DADO PER PERNO CERNIERA REG. M/106-220	NUT FOR UPPER DOOR HINGE	ECROU CHEVILLE CHARNIERE SUPERIEURE	MUTTER F. OBERES SCHARNIERSTIFT	TUERCA PARA PERNO BISAGRA SUPERIOR
13	R62060223	1	DADO PILOTA TUBO D.6 0903/1.	NUT D.6	ECROU D. 6	MUTTER D.6	DADO D.6
14	R65110200	1	E.V. 1 VIA 220V 50HZ X J.G. CON ATTACC	SOLENOID VALVE 1 VIA 220V 50HZ	ELECTROVANNE 1 VIA 220V 50HZ	MAGNETVENTIL 1 VIA 220V 50HZ	ELECTROVALVULA 1 VIA 220V 50HZ
15	R65110230	1	E.V. 2VIE 1P+1D 220V/50HZ J.G. CON ATTACC	SOLENOID VALVE 2 VIE 220V 50HZ	ELECTROVANNE 2 VIE 220V 50HZ	MAGNETVENTIL 2 VIE 220V 50HZ	ELECTROVALVULA 2 VIE 220V 50HZ
16	R61630011	2	FASCETTE ZINC.12-22/9	METAL CLAMPS 12-22/9	COLLIER DE SERRAGE 12-22/9	VERZINKTE SCHELLEN 12-22/9	ABRAZADERA 12-22/9
17	R61630031	4	FASCETTE ZINC.40-60/9	METAL CLAMPS 40-60/9	COLLIER DE SERRAGE 40-60/9	VERZINKTE SCHELLEN 40-60/9	ABRAZADERA 40-60/9
18	R65280490	1	FERRITE TOROIDALE FT36	FERRITE FT36	FERRITE FT36	FERRIT FT36	FERRITA FT36
19	R65280200	3	FILTRO Cx=0,47µF Cy=2X10nF	INTERFERENCE SUPPRESSOR	FILTRE ANTIPARASITES	STOERSCHUTZFILTER	FILTRO
20	R69180250	1	FILTRO SCARICO BACINELLA	SUPPRESSOR	FILTRE	FILTER	FILTRO
21	R58003860	1	FLANGIA GUARN. PICCOLA	MOTOR GASKET BRASS FLANGE	BRIDE JOINT MOTEUR	FLANSCH F. MOTORDICHTUNG	BRIDA JUNTA MOTOR
22	R70010030	1	GUARNIZIONE OR 6,07 X 1,78 SILICONE	GASKETS OR 6,07 X 1,78	JOINT OR 6,07 X 1,78	RINGDICHTUNG OR 6,07 X 1,78	JUNTA OR 6,07 X 1,78
23	R70010050	1	GUARNIZIONE OR 7,60 X 2,62 OR 3030 NB	GASKETS OR 7,60 X 2,62	JOINT OR 7,60 X 2,62	RINGDICHTUNG OR 7,60 X 2,62	JUNTA OR 7,60 X 2,62
24	R70020040	1	GUARNIZIONE MARK IV MLA 1500.02.05	GASKET	JOINT	RINGDICHTUNG	JUNTA
25	R70010210	1	GUARNIZIONE OR NBR 70 18,72x2,62 C.3075	GASKETS OR NBR 70 18,72x2,62	JOINT OR NBR 70 18,72x2,62	RINGDICHTUNG OR NBR 70 18,72x2,62	JUNTA OR NBR 70 18,72x2,62
26	R65070230	1	GUARNIZIONE PER TERM.SIC.CA-MERM/106-110	GASKET	JOINT	RINGDICHTUNG	JUNTA
27	R70010130	1	GUARNIZIONE SILICONE ROSSO 80x50,3x3	GASKET	JOINT	RINGDICHTUNG	JUNTA
28	R70050150	1	GUARNIZIONE X TAPPO 2" PLAST.G40005	GASKET	JOINT	RINGDICHTUNG	JUNTA
29	R62030118	1	MANICOTTO RIDUZ.F.1/8-1/4 CIL. PRDI222100	1/8"-1/4" FEMALE REDUCTION COUPLING	MANCHON REDUCTION 1/8" - 1/4"	REDUZIERMUFFE 1/8" - 1/4" F	MANGUITO REDUCCION HEMBRA 1/8"-1/4"
30	R70060080	1	MANICOTTO SILICONE D.13X18X80	SILICON SLEEVE	SILICONE SLEEVE	SILIKONHÜLLE	FUNDA DE SILICONA
31	R70060020	1	MANICOTTO SILICONE D.30X35X9 TAPPO SFIA	SILICON SLEEVE	SILICONE SLEEVE	SILIKONHÜLLE	FUNDA DE SILICONA
32	R70060040	2	MANICOTTO SILICONE D.50X50X3	SILICON SLEEVE	SILICONE SLEEVE	SILIKONHÜLLE	FUNDA DE SILICONA
33	R75300020	1	MASCHERINA VENTILATORE D.120 PER VENT.	FAN GUARD GRID D.120	GRILLE VENTILATEUR D.120	VENTILATORSCHUTZGITTER D.120	REJILLA VENTILADOR D.120
34	R75300060	1	MASCHERINA VENTILATORE D.270	FAN GUARD GRID D.270	GRILLE VENTILATEUR D.270	VENTILATORSCHUTZGITTER D.270	REJILLA VENTILADOR D.270
35	R65265100	1	MICRO PORTA MAGNETICO COMPLETO RIC.	DOOR SWITCH	MICRO PORTE	TUERSCHALTER	MICRO PUERTA
36	R65220091	1	MORSETTIERA LX2E (TIPO 2) NEW	TERMINAL BOARD	BORNIER	KLEMMLEISTE	REGLETERA
37	R65040420	1	MOTORE KW 037 2P 220/240V 1057	MOTOR	MOTEUR	MOTOR	MOTOR
38	R69010260	1	NASELLO 1 STEP 6303-020022	DOOR LATCH 1 STEP	GACHE DE PORTE POUR OUVERTURE SIMPLE	SCHLISSNASE 1 STUFE	NARIZ 1 CIERRE

ATTENZIONE: PER ORDINARE I RICAMBI, SPECIFICARE SEMPRE IL MODELLO DI FORNO ED IL NUMERO DI MATRICOLA
ATTENTION: WHEN ORDERING SPARE PARTS, PLEASE ALWAYS SPECIFY THE OVEN MODEL AND THE SERIAL NUMBER

ATTENTION: POUR COMMANDER DES PIECES, MERCI DE SPECIFIER TOUJOURS LE MODELE DU FOUR ET LE NUMERO DE SERIE
ACHTUNG: UM ERSATZTEILE ZU BESTELLEN, BITTE IMMER OFEN-MODELL UND SERIENNUNMMER GEBEN.

ed. 0713

POS.	COD.	Pz.	DESCRIZIONE	DESCRIPTION	DESCRIPTION	BESCHREIBUNG	DESCRIPCIÓN
39	R58003140	2	PERNO AGGANCIO DEFLETTORE	FAN GUARD PANEL PIN	PIVOT DEFLECTEUR	BOLZEN FÜR LUFTLEITBLECH	PERNO CIERRE DEFLECTOR
40	R58003110	2	PERNO FISSAGGIO DEFLETTORE	FAN GUARD PANEL PIN	PIVOT DEFLECTEUR	BOLZEN FÜR LUFTLEITBLECH	PERNO CIERRE DEFLECTOR
41	R58002670	1	PERNO INF.CERNIERA REG.C/FERMI SR.2005	LOWER HINGE PIN	CHEVILLE CHARNIERE INFERIEURE	UNTERES SIE SCHARNIERSTIFT	PERNO INFERIOR BISAGRA
42	R58002150	1	PERNO SUP.CERNIERA REG. M/106-220	UPPER HINGE PIN	CHEVILLE CHARNIERE SUPERIEURE	OBERES SCHARNIERSTIFT	PERNO SUPERIOR BISAGRA
43	R65210020	3	PORTAFUSIBILE BARRA DIN 5x20	FUSE CARRIER	PORTE-FUSIBLE	SICHERUNGSHALTER	PORTAFUSIBILE
44	R65240030	1	PRESSACAVO PG 107 Z/29 (RACCORDO)	FAIRLEAD	PRESSE CABLE	ZUGENTLASTUNG	PRENSACABLES
45	R63070050	1	PRESSOSTATO 1/8" 0,5-0,35 BAR PH/91140	WATER SAFETY PRESSURE SWITCH	INT.A PRESSION SEC.-EAU	WASSER-DRUCKWACHTER	PRESOSTATO AQUA
46	R65090220	1	PROGRAMMAT. 1 CAMME V220/50HZ 1 CIRCUITO	DAMPER SYSTEM	SORTIE EVAPORATION MOUFLE	DAMPFABLASS-STELLMOTOR	MOTOR RESPIRADERO COMPLETO
47	R62090478	3	RACC. INTERMEDIO A GOMITO D.10 PM0310E	ELBOW PIPE FITTING	COURBE AVEC QUEUE	STUCK MIT SCHAFT	RACOR CON CODO
48	R62090508	2	RACC.TERMIN.DIR.FIL.CON.10X1/4 PM011002E	10X1/4 STRAIGHT THREADED TERMINAL PIPE FITTING	RACCORDEMENT	ENDVERBINDUNGSSTUCK 10 X 1/4" GESCHNITTEN	RACOR
49	R62090633	1	RACCORDO OTTONE CURVO 10/10 C/OGIVA	ELBOW PIPE FITTING BRASS D.10	RACCORDEMENT A COUDE LAITON D 10	WINKELSTUTZEN AUS MESSING D,10	RACOR LATON DE GOMA D.10
50	R65110500	1	REGOL. PORTATA MARRONE ALPHAT. 8L/h	8 LT/H WATER FLOW REDUCER	REGULATUER DE DEBIT 8 LT.	DURCHFLUSSMONDERER 8L/STD.	REGULADOR DE CAUDAL 8 LT.
51	R65011930	1	RESISTENZA 10000W230V D8.5 INC. CAM.K 081	CHAMBER HEATING ELEMENT 10000W230V	RESISTANCE MOUFLE 10000W230V	GARRAUM HEIZKOERPER 10000W230V	RESISTENCIA CAMARA 10000W230V
52	R69180120	1	SCATOLA COND.SCARICO G/MV T06-T10-T21	QUENCHING-DRAIN COLLECTOR	BOITE DE CONDENSATION DECHARGE	KONDENSATION-ABFLUSS SCHACHTEL	CAJON CONDENSACION-DESAGÜE
53	R65320220	2	SONDA "K" 6X80 1,5ML. TESTA RASTREM.20mm	PROBE "K" 6X80 1,5ML.	SONDE "K" 6X80 1,5ML.	FUEHLER "K" 6X80 1,5ML.	SONDA "K" 6X80 1,5ML.
54	R69150100	1	TAPPO FEMMINA G 2" PP+25%FV NERO	COVER	BOUCHON	ABDECKUNG	TAPON
55	R65140700	5	TELERUTTORE DIL M9-01 4KW-20A MOELLER	CONTACTOR	CONTACTEUR	SCHUETZ	CONTACTOR
56	R65160310	1	TERMICO T12-211S-2,5A	THERMIC PROTECTION T12-211S-2A	PROTECTION THERMIQUE T12-211S-2A	MOTORSCHUTZSCHALTER T12-211S-2A	TERMICO T12-211S-2A
57	R62090868	1	TERMINALE CIECO D.10 PSE4610W	PIPE FITTING	COURBE	STUCK	RACOR
58	R65070350	1	TERMOSTATO SICUR. 360°C -25K 55.32572.8	THERMOSTAT	THERMOSTAT	THERMOSTAT	TERMOSTATO
59	R65180420	2	TRASF.RE 20VA 0-220-240/12V MOD.163.16	TRANSFORMER 20VA	TRANSFORMATEUR 20VA	TRANSFORMATOR 20VA	TRANSFORMADOR 20VA
60	R80150000	1	TUBO PE 10MMX7 AZZURRO PM950612E	BLUE PIPE	TUBE	LEITUNG	TUBO
61	R80120030	0,08 m	TUBO SILICONE ROSSO SR60 18/13.	PIPE	TUBE	LEITUNG	TUBO
62	R58006160	2	UGELLO COND.D.0,8 CODOLO CIL.10	NOZZLE	BEK	DÜSE	BOQUILLA
63	R65060050	2	VENTILATORE COMPATTO D.120 4715MS 23T	COMPONENTS VENTILATION MOTOR D.120	MOTEUR DE REFOIDISSMENT D.120	ABKULUNGS MOTOR D.120	MOTOR DE ENFRIAMIENTO D.120
64	R75400570	1	VENTOLA D.240X80/6 P.D. 50HZ . K_081 T07	FAN	TURBINE	LUEFTERRAD	PALA VENTILADOR
65	R61260152	2	VITE TCB+A2 M 4X10	SCREW TCB+A2 M 4X10	VIS TCB+A2 M 4X10	SCHRAUBE TCB+A2 M 4X10	TORNILLO TCB+A2 M 4X10
66	R10100140	1	TAPPO SFIATO COMPLETO M/106.-.220	COVER	BOUCHON	ABDECKUNG	TAPON

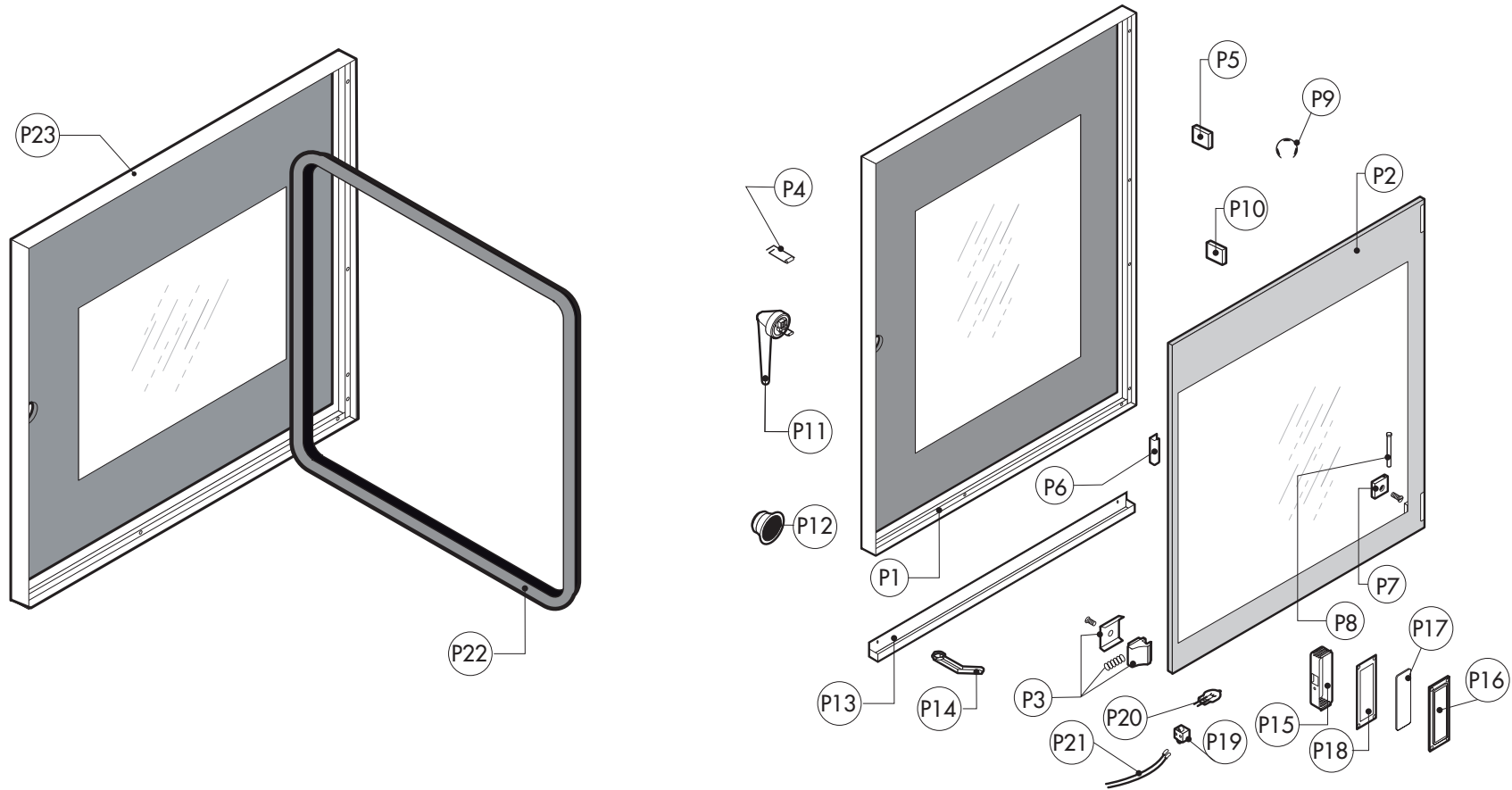

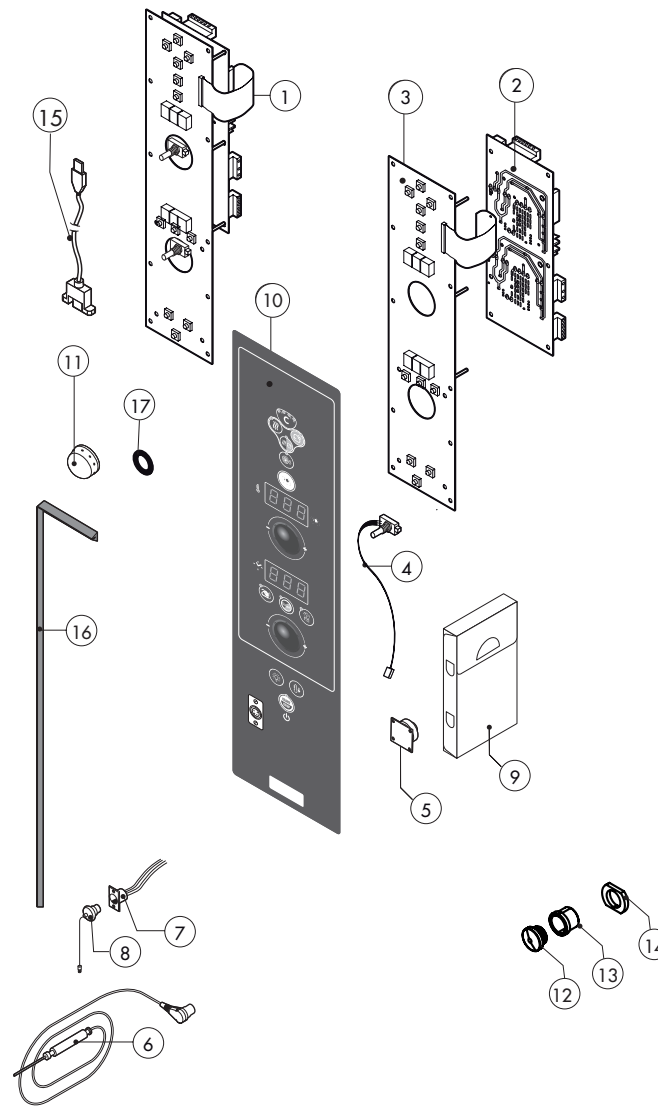

ATTENZIONE: PER TENSIONI SPECIALI, SPECIFICARE SEMPRE IL MODELLO DI FORNO ED IL NUMERO DI MATRICOLA
ATTENTION: FOR SPECIAL VOLTAGES, PLEASE ALWAYS SPECIFY THE OVEN MODEL AND THE SERIAL NUMBER

ATTENTION: POUR TENSIONS SPÉCIALES, MERCI DE SPÉCIFIER TOUJOURS LE MODÈLE DU FOUR ET LE NUMÉRO DE SÉRIE
ACHTUNG: BEI SONDRERSPANNUNGEN, BITTE IMMER OFEN-MODELL UND SERIENNUMMER GEBEN.

ed. 0713

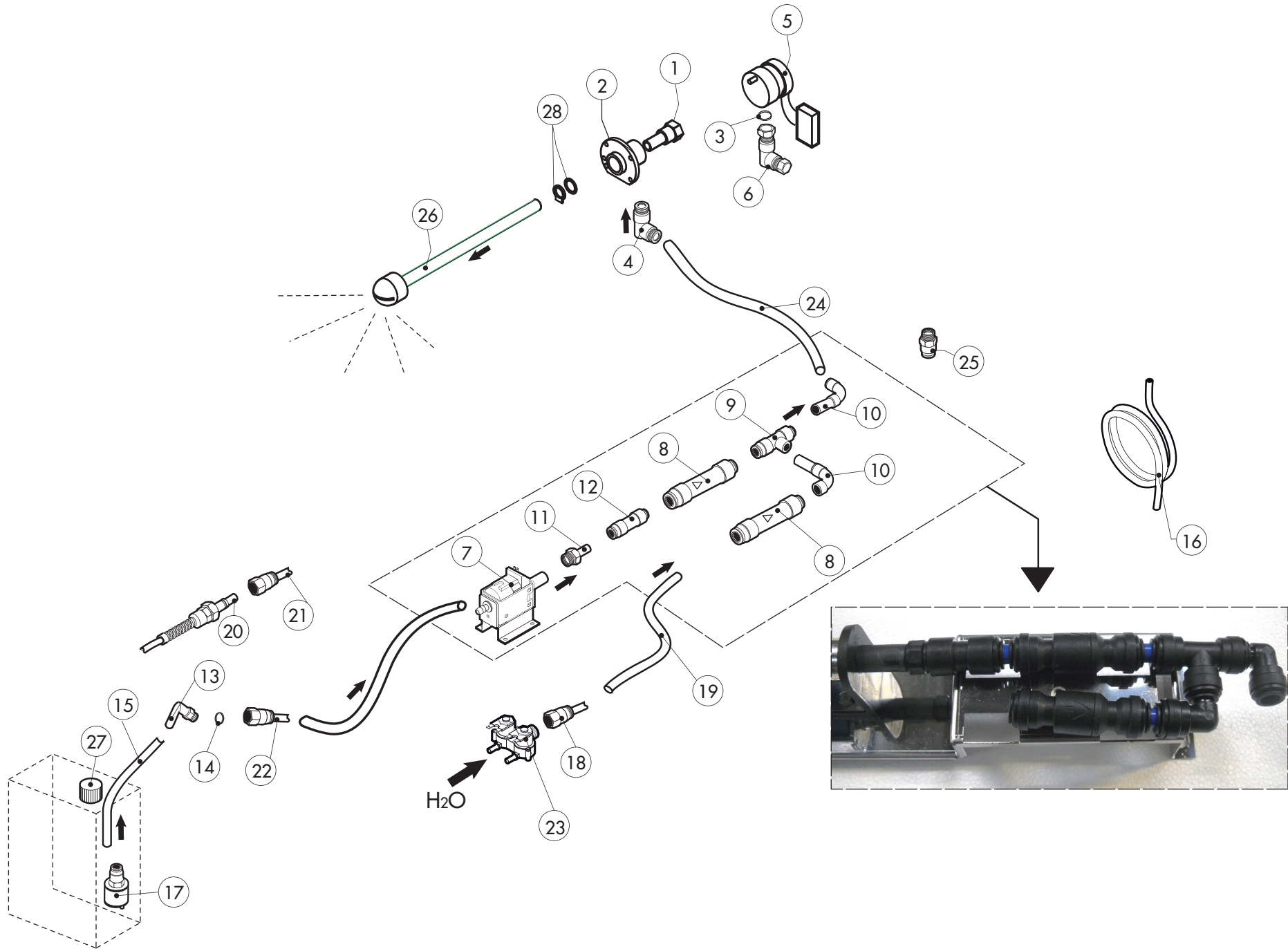

ATTENZIONE: PER ORDINARE I RICAMBI, SPECIFICARE SEMPRE IL MODELLO DI FORNO ED IL NUMERO DI MATRICOLA
ATTENTION: WHEN ORDERING SPARE PARTS, PLEASE ALWAYS SPECIFY THE OVEN MODEL AND THE SERIAL NUMBER

ATTENTION: POUR COMMANDER DES PIÈCES, MERCI DE SPECIFIER TOUJOURS LE MODÈLE DU FOUR ET LE NUMÉRO DE SÉRIE
ACHTUNG: UM ERSATZTEILE ZU BESTELLEN, BITTE IMMER OFEN-MODELL UND SERIENNUMMER GEBEN.

ed. 0713

POS.	COD.	Pz.	DESCRIZIONE	DESCRIPTION	DESCRIPTION	BESCHREIBUNG	DESCRIPCIÓN
1	R58007000	1	PERNO ROTANTE LAVAGGIO MOB	ROTATING PIVOT	PIVOT TOURNANT	UMLAUFENDE STÜTZE	GOZNE ROTATORIO
2	R58007020	1	FLANGIA LAVAGGIO MOB	WASHING SYSTEM FLANGE	BRIDE BRAS DE LAVAGE	FLANSCH WASCHARMBEFESTIGUNG	PLATINA LAVADO
3	R70010080	1	GUARNIZIONE OR 14x2 Viton DIN 981	GASKETS	JOINT	RINGDICHTUNG	JUNTA
4	R62090663	1	RACCORDO OTTONE NICH.A L C/OGIVA 10X1/4"	ELBOW PIPE FITTING BRASS D.10x1/4"	RACCORDEMENT A COUDE LAITON D 10x1/4"	ELBOW PIPE FITTING BRASS D.10x1/4"	RACOR LATON DE GOMA D.10x1/4"
5	R65090250	1	MOTORID. LAV. SAIA-BURGESS 175022044028-A	WASHING GEARED MOTORS	MOTO-REDUCTEURS DE LAVAGE	GETRIEBEMOTOREN	MOTORREDUCTORES LAVADO
6	R62090633	1	RACCORDO OTTONE CURVO 10/10 C/OGIVA	ELBOW PIPE FITTING BRASS D.10	RACCORDEMENT A COUDE LAITON D 10	WINKELSTUTZEN AUS MESSING D,10	RACOR LATON DE GOMA D.10
7	R65110600	1	POMPA ELETTRON.A PIS.OSC.ET508LAB 2273	POMPE DETERGEANT	DETRGENT PUMP	REINIGERPUMPE	BOMBA DETERGENTE
8	R65110680	2	VALVOLA ANTIRITORNO J.G. 10SCV	ANTI-BACK FLOW	ANTIRETOUR	RUCKFLUSSVERHINDERER	ANTIRETORNO
9	R62090468	1	RACCORDO INTERMEDIO A "T" D.10 PM0210E	T MIDLING PIPE FITTING D.10	RACCORD INTERMEDIAIRE A "T" D.10	MITTELVERBINDUNGSSTUCK D.10 "T"- FORMIG	RACOR INTERMEDIO TIPO "T" D.10
10	R62090528	2	RACC.A GOMITO C/CODOLO 10X10 PM221010E	ELBOW PIPE FITTING (WITH TANG) 10 X 10	COURBE AVEC QUEUE 10x10	WINKELVERBINDUNGSSTUCK 10 X 10 MIT SCHAFT	RACOR DE GOMA CON CODO 10x10
11	R62090608	2	TERMINALE C/CODOLO 8x1/8" PM050811E	8X1/8 END SIDE PIPE FITTING (WITH TANG)	RACCORD AVEC QUEUE 8x1/8"	ENDVERBINDUNGSSTUCK 8 X 1/8" MOT SCHAFT	RACOR TERMINAL CON CODO 8x1/8"
12	R62090618	1	RIDUZIONE INTERMEDIA 10-8 PM201008E	REDUCTION PIPE FITTING	RACCORD DROIT REDUCTION	GERADE ANSCHLUSS-VERKLEINERUNG	RACOR DERECHO REDUCCION
13	R62090678	1	RACC.A GOMITO C/CODOLO 8X8 PM220808E	ELBOW PIPE FITTING (WITH TANG) 8 X 8	COURBE AVEC QUEUE 8x8	WINKELVERBINDUNGSSTUCK 8X8 MIT SCHAFT	RACOR DE GOMA CON CODO 8x8
14	R70010050	4	GUARNIZIONE OR 7,60 X 2,62 OR 3030 NB	GASKETS	JOINT	RINGDICHTUNG	JUNTA
15	R80150020	2m	TUBO DETERGENTE PE D.8mm x 6	PE D.8 MM X 6 DETERGENT FLEXIBLE PIPE	TUBE DETERGEANT D. 8x6	ROHRLEITUNG F. REINIGER PE D.8MMX6 (2MT)	TUBO DETERGENTE PE D.8mm X 6
16	R70070080	1m	TUBO CARICO ACQUA D.23mm x13	PIPE	TUBE	LEITUNG	TUBO
17	R65110650	1	VALVOLA DI FONDO PER FILTRO GM.060.35	BOTTOM FILTER	FILTER POUR TUBE DETERGEANT	ANSAUGFILTER F. REINIGUNGSSCHAUCH	VÁLVULA DE FONDO TUBO DEL LIMPIADOR
18	R62020118	1	NIPPLES MASCHIO CONICO 1/4" PNID020200	STRAIGHT THREADED TERMINAL PIPE FITTING	RACCORD FILETE DROIT	ENDVERBINDUNGSSTUCK GESCHNITTEN	RACOR TERMINAL DERECHO ROSCADO
19	R80120060	1m	TUBO SILIC. TRASP.SR60/TR 7/12.	PIPE	TUBE	LEITUNG	TUBO
20	R62090482	1	RACC.RAPIDO MASCHIO X LAVAG. PIPU40-C08M	RAPID MALE PIPE FITTING	RACCORD RAPIDE PARTIE MALE	SCHNELLVERBINDUNG MANNL	RACOR RAPIDO MACHO
21	R62090638	1	RACC.RAP.FEMM.X LAV.FIL.FEMM PVPJ40-F1/4	RAPID FEMALE PIPE FITTING	RACCORD RAPIDE PARTIE FEMELLE	SCHNELLVERBINDUNG	RACOR RAPIDO HEMBRA
22	R62090538	1	RACC.DIR.F.1/4"TUBO6X8 A CALZ. PRCF220008	1/4" FEMALE STRAIGHT PIPE FITTING FOR D.6X8 PIPE	RACCORD DROIT PARTIE FEMELLE 1/4" TUBE 6x8	VERBINDUNGSSTUCK 1/4" WEBL. FUR ROHR D.6X8	RACOR DERECHO HEMBRA 1/4" PARA TUBO D.6x8
23	R65110210	1	E.V. 2 VIE 220V 50HZ X J.G.CON ATTACC	SOLENOID VALVE 220V 50HZ	ELECTROVANNE 220V 50HZ	MAGNETVENTIL 220V 50HZ	ELECTROVALVULA 220V 50HZ
24	R80150000	1m	TUBO PE D.10mm x 7 AZZURRO	PE D.10 MM X7 WATER FLEXIBLE PIPE	TUBE FLEXIBLE EAU D. 10x7	WASSERFLEXROHRLEITUNG PE D.10MMX7	TUBO FLEXIBLE AGUA PE D.10mm X 7
25	R62090688	1	RACC.TERMIN.DIR.FIL.CON.8X1/4 NC2500-P	8x1/4 STRAIGHT THREADED TERMINAL PIPE FITTING	RACCORD FILETE DROIT 8x1/4"	ENDVERBINDUNGSSTUCK 8x1/4" GESCHNITTEN	RACOR TERMINAL DERECHO ROSCADO 8x1/4"
26	R58007040	1	TESTA LAVAGGIO MOB+ALBERO L=120 (071/T06)	WASHING SYSTEM INNER ASSEMBLY	ENSEMBLE INTERIEUR DU LAVAGE	INNEN WASCHARMBEFESTIGUNG	KIT INTERNO LAVADO
27	R58005060	1	TAPPO TANICA GIALLO x LAVAGGIO	COVER	BOUCHON	ABDECKUNG	TAPON
28	R70045120	1	KIT GUARNIZIONI X LAVAGGIO MOB	GASKETS KIT	ENSEMBLE JOINTS	DICHTUNGSSATZ	KIT JUNTAS