

Ersatzteilliste
Spare parts list
Lista di ricambi



Gläserespülautomat
Glasswashing machine
Lavabicchieri

EcoStar 430 F

Esecuzione standard



gültig ab / valid from / valado a partire dal 1.11.98

MEIKO Maschinenbau GmbH & Co., Postfach 2040, D-77652 Offenburg, Tel.: (0781) 203-0, Fax.: (0781) 203-274

EcoStar 430 F

Inhaltsverzeichnis:

- 1.1 Waschpumpe HALLO
- 2.4 Pumpenansaugung
- 3.10 Wasch- und Nachspülsystem
- 4.8 Magnetventil
- 5.1 Rücksaugeverhinderer
- 6.3 Niveauregelung
- 8.20 Einbauboiler
- 9.1 Tankheizung
- 10.5 Klarspülerdosierung
- 11.22 Elektroniksteuerung
- 12.8 Elektroteile
- 13.18 Baugruppen/Einzelteile
- 18.1 Laugenpumpe

Contents:

- 1.1 Wash pump
- 2.4 Pump suctioning
- 3.10 Washing and rinsing system
- 4.8 Solenoid valve
- 5.1 Reflux preventor
- 6.3 Level control
- 8.20 Incorporated boiler
- 9.1 Tank heating
- 10.5 Rinse aid dosing unit
- 11.22 Electronic control
- 12.8 Electrical parts
- 13.18 Component blocks/Parts
- 18.1 Lye pump

Indice:

- 1.1 Pompa di lavaggio
- 2.4 Aspirazione pompa
- 3.10 Sistema di lavaggio e risciacquo
- 4.8 Elettrovalvola
- 5.1 Dispositivo di non ritorno
- 6.3 Regolazione di livello
- 8.20 Boiler incorporato
- 9.1 Riscaldamento della vasca
- 10.5 Dosatore del brillantante
- 11.22 Comando elettronico
- 12.8 Ricambi elettrici
- 13.18 Blocchi di componenti / pezzi
- 18.1 Pompa di scarico

* Raccomandiamo di avere in depositi questi ricambi!

Ci riserviamo i diritti di apportare modifiche d'esecuzione e di costruzione.

Ersatzteilliste
Spare parts list
Lista di ricambi



Gläserpülautomat
Glasswashing machine
Lavabicchieri

EcoStar 530 F

Esecuzione standard



gültig ab / valid from / valado a partire dal 1.11.98

MEIKO Maschinenbau GmbH & Co., Postfach 2040, D-77652 Offenburg, Tel.: (0781) 203-0, Fax.: (0781) 203-274

EcoStar 530 F

Inhaltsverzeichnis:

- 1.1 Waschpumpe
- 2.3 Pumpenansaugung
- 3.13 Wasch- und Nachspülsystem
- 4.8 Magnetventil
- 5.1 Rücksaugeverhinderer
- 6.3 Niveauregelung
- 8.20 Einbauboiler
- 9.1 Tankheizung
- 10.5 Klarspülerdosierung
- 11.22 Elektroniksteuerung
- 12.8 Elektroteile
- 13.17 Baugruppen/Einzelteile
- 18.1 Laugenpumpe

Contents:

- 1.1 Wash pump
- 2.3 Pump suctioning
- 3.13 Washing and rinsing system
- 4.8 Solenoid valve
- 5.1 Reflux preventor
- 6.3 Level control
- 8.20 Incorporated boiler
- 9.1 Tank heating
- 10.5 Rinse aid dosing unit
- 11.22 Electronic control
- 12.8 Electrical parts
- 13.17 Component blocks/Parts
- 18.1 Lye pump

Indice:

- 1.1 Pompa di lavaggio
- 2.3 Aspirazione pompa
- 3.13 Sistema di lavaggio e risciacquo
- 4.8 Elettrovalvola
- 5.1 Dispositivo di non ritorno
- 6.3 Regolazione di livello
- 8.20 Boiler incorporato
- 9.1 Riscaldamento della vasca
- 10.5 Dosatore del brillantante
- 11.22 Comando elettronico
- 12.8 Ricambi elettrici
- 13.17 Blocchi di componenti / pezzi
- 18.1 Pompa di scarico

* Raccomandiamo di avere in depositi questi ricambi!

Ci riserviamo i diritti di apportare modifiche d'esecuzione e di costruzione.

1.1 WASCHPUMPE (0,55 KW)

1.1 WASH PUMP (0,55 KW)

1.1 POMPA DI LAVAGGIO (0,55 KW)



EcoStar430-530F E-liste_i
1.5.95/FH

IDENT. NR. CODICE	BEZEICHNUNG	DESIGNATION	DESCRIZIONE
* 0501085	PUMPE PU 0,5/3911, 0,55 KW 230 V 50 HZ, 2800 U/MIN	PUMP PU 0,5/3911, 0,55 KW 230 V 50 HZ, 2800 RPM	POMPA PU 0,5/3911, 0,55 KW 230 V 50 HZ, 2800 GIRI/MIN
0501105	LAGERSCHILD MIT PUMPEN- DECKEL	END SHIELD WITH PUMP LID0	FLANGIA FINALE CON COPERCHIO POMPA
* 0501094	PUMPENGEHÄUSEDICHTUNG	PACKING FOR PUMP HOUSING	GUARNIZIONE CORPO POMPA
* 0501095	GLEITRINGDICHTUNG KPL.	SLIDING SEAL COMPL.	ANELLO TENUTA COMPL.
* 0501092	PUMPENLAUFRAD	PUMP WHEEL	GIRANTE
0501091	PUMPENGEHÄUSE	PUMP HOUSING	CORPO POMPA
0303015	SECHSKANTSCHRAUBE DIN 933 M 4 X 25	HEXAGON SCREW DIN 933 M 4 X 25	VITE ESAGONALE DIN 933 M 4 X 25
0335005	SECHSKANTMUTTER DIN 934 M 4	HEXAGON NUT DIN 934 - M 4	DADO ESAGONALE DIN 934 - M 4
0467010	TYPENSCHILD (NICHT GEZEICHNET)	LABEL (NOT DESIGNED)	TARGHETTA (NON DISEGNATA)
* 0501090	KONDENSATOR 12 µF	CONDENSER 12 µF	CONDENSATORE 12 µF
0233046	SCHLAUCHKLEMME 32 - 50	HOSE CLAMP 32 - 50	COLLARE 32 - 50
0640007	SCHLAUCH SCHWARZ DIN 904 - Ø38 X 4	HOSE BLACK DIN 904 - Ø38 X 4	FLESSIBILE NERO DIN 904 - Ø38 X 4
8002454	SCHLAUCH GLASKLAR Ø35 X 5 X 70	HOSE TRANSPARENT Ø35 X 5 X 70	FLESSIBILE TRASPARENTE Ø35 X 5 X 70

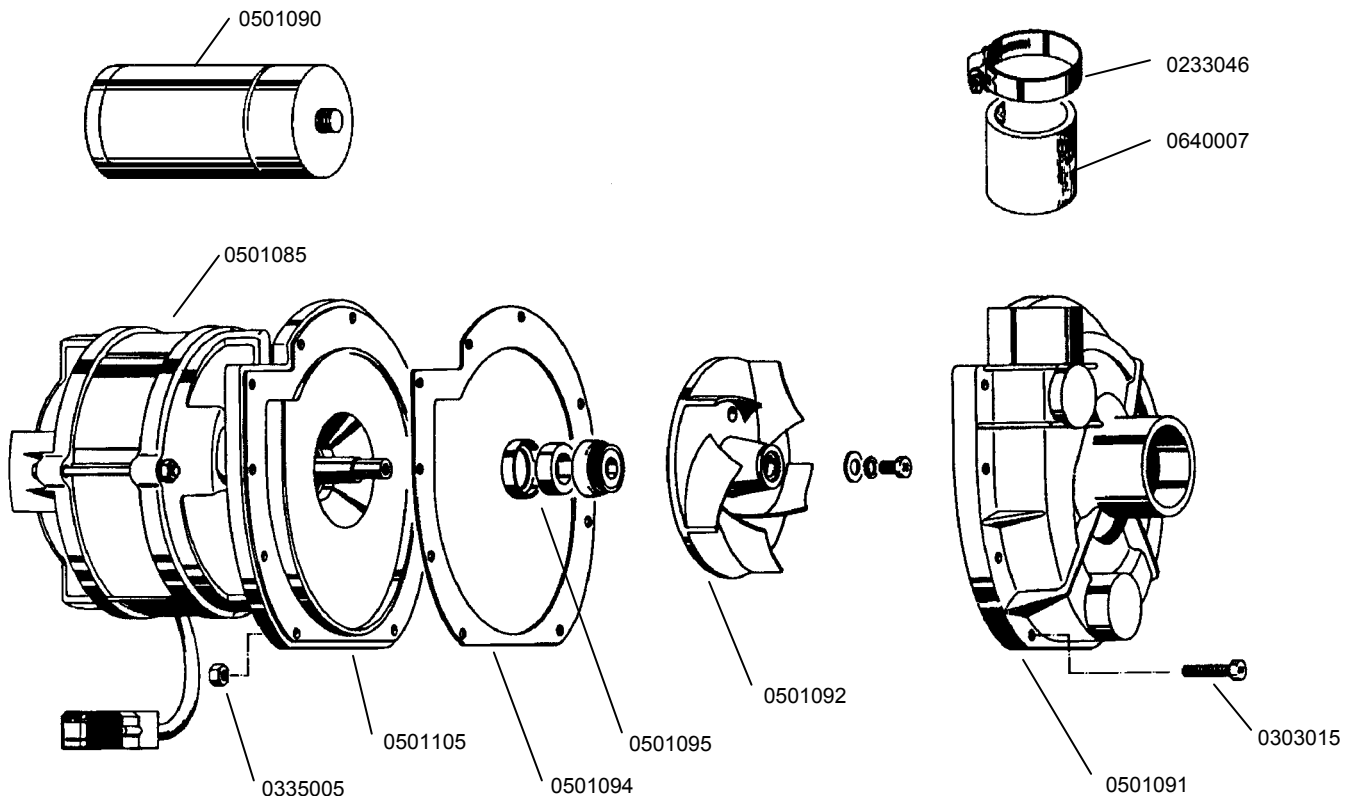

2.3 PUMPENANSAUGUNG

2.3 PUMP SUCTIONING

2.3 ASPIRAZIONE POMPA



EcoStar430-530F E-liste_i
1.8.96/FH

IDENT. NR. CODICE	BEZEICHNUNG	DESIGNATION	DESCRIZIONE
0620347	STANDROHR, 140 LANG FV 20/40/70 T	STAND PIPE, 140 LONG FV 20/40/70 T	TROPPOPIENO 140 LUNGO FV 20/40/70 T
0620348	STANDROHR, 175 LANG DV 40/80/120 B	STAND PIPE, 175 LONG DV 40/80/120 B	TROPPOPIENO 175 LUNGO DV 40/80/120 B
0620346	SIEB MIT SCHMUTZRINNE K 337	FILTER WITH DIRT TRAP K 337	FILTRO CON CANALETTA RESIDUI K 337
* 0401061	O-RING 206,5 X 3,53	O-RING 206,5 X 3,53	ANELLO O-RING 206,5 X 3,53
8003639	PUMPENSUMPF FV 20/40/70 T	PUMP SUMP FV 20/40/70 T	VASCHETTA POMPA FV 20/40/70 T
8004844	PUMPENSUMPF FV 20/40/70 T MIT FREIEM AUSLAUF UND ECOSTAR 530 F	PUMP SUMP FV 20/40/70 T WITH AIR GAP AND ECOSTAR 530 F	VASCHETTA POMPA FV 20/40/70 T CON USCITA LIBERA E ECOSTAR 530 F
8003669	PUMPENSUMPF DV 40/80	PUMP SUMP DV 40/80	VASCHETTA POMPA DV 40/80
8003787	PUMPENSUMPF DV 120 B	PUMP SUMP DV 120 B	VASCHETTA POMPA DV 120 B
0233041	SCHLAUCHKLEMME 40 - 60	HOSE CLAMP 40 - 60	COLLARE 40 - 60
8002570	SCHLAUCH GLASKLAR Ø35 X 5 X 55	HOSE, TRANSPARENT Ø35 X 5 X 55	FLESSIBILE TRASPARENTE Ø35 X 5 X 55
0233046	SCHLAUCHKLEMME 32 - 50	HOSE CLAMP 32 - 50	COLLARE 32 - 50

PA2_3

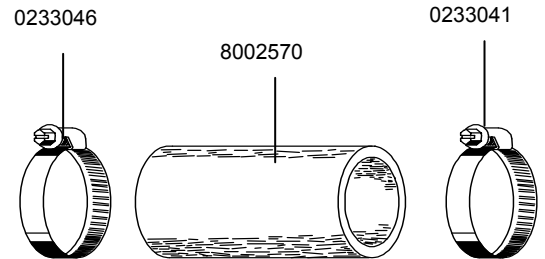
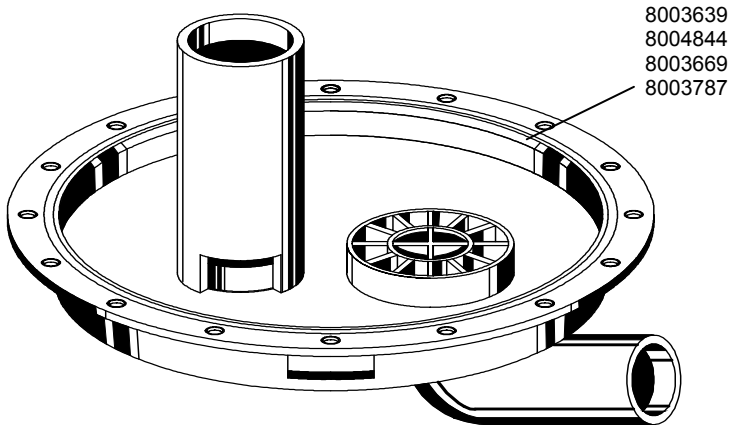
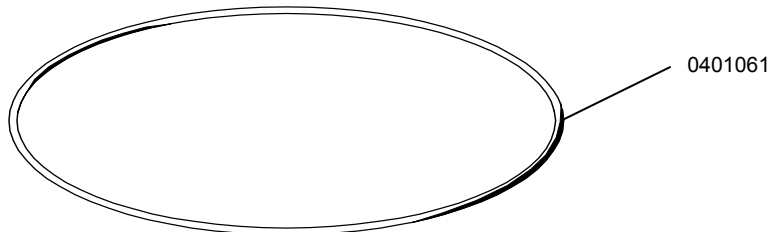
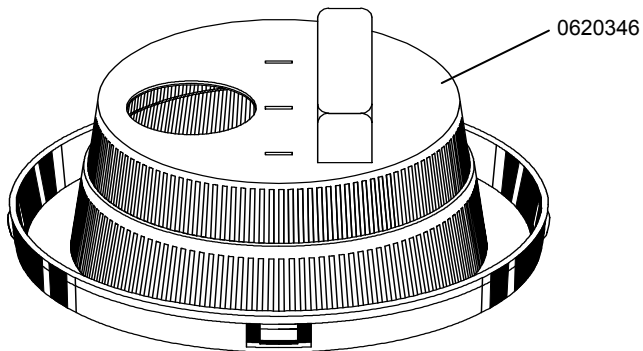
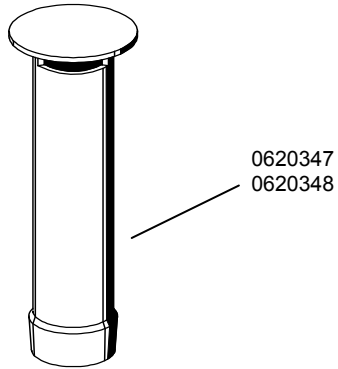

2.4 PUMPENANSAUGUNG

2.4 PUMP SUCTIONING

2.4 ASPIRAZIONE POMPA



EcoStar430-530F E-liste_i
1.11.96/FH

IDENT. NR. CODICE	BEZEICHNUNG	DESIGNATION	DESCRIZIONE
0620347	STANDROHR 140 LANG	STAND PIPE 140 LONG	TROPPOPIENO 140 LUNGO
0620431	SIEB MIT SCHMUTZRINNE K 383	FILTER WITH DIRT TRAP K 383	FILTRO CON CANALETTA RESIDUI K 383
* 0401070	O-RING 122 X 3	O-RING 122 X 3	ANELLO O-RING 122 X 3
0620430	PUMPENSUMPF	PUMP SUMP	VASCHETTA POMPA
0340027	UNTERLEGSCHIEBE DIN 522 - 5,8 X 11 X 1	WASHER DIN 522 - 5,8 X 11 X 1	RONDELLA DIN 522 - 5,8 X 11 X 1
0337001	SECHSKANTMUTTER SELBST- SICHERND, DIN 985 - M 5	HEXAGON NUT SELFLOCKING DIN 985 - M 5	DADO DIN 985 - M 5
0233041	SCHLAUCHKLEMME 40 - 60	HOSE CLAMP 40 - 60	COLLARE 40 - 60
0640014	SCHLAUCH Ø45 X 5	HOSE Ø45 X 5	FLESSIBILE Ø45 X 5

PA2_4

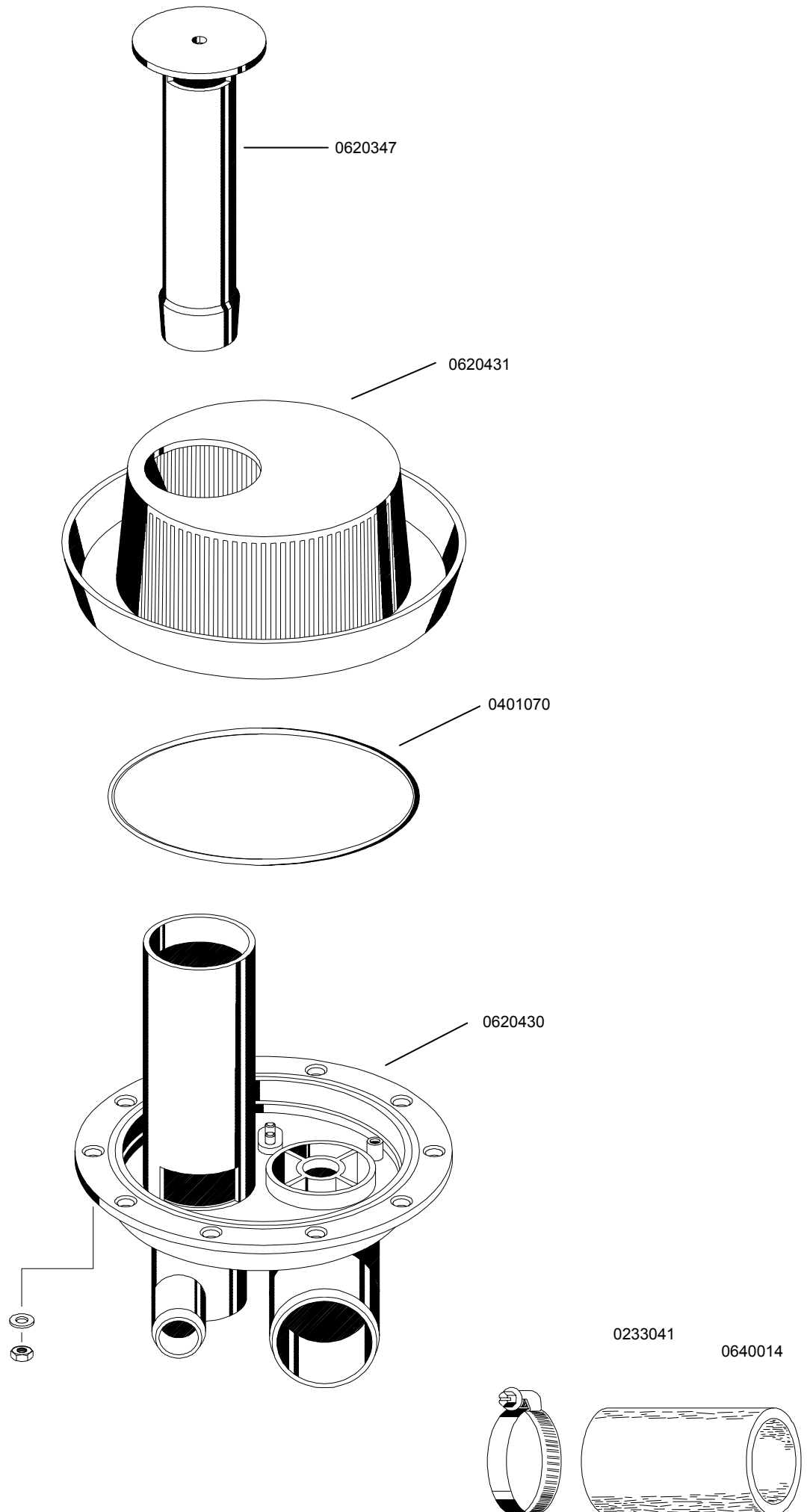

3.10 WASCH- UND NACHSPÜLSYSTEM

3.10 WASHING AND RINSING SYSTEM

3.10 SISTEMA DI LAVAGGIO E RISCIAQUO



EcoStar430-530F E-liste_i
1.12.97/FH

IDENT. NR. CODICE	BEZEICHNUNG	DESIGNATION	DESCRIZIONE
0620429	DÜSENUNTERSATZ K 385/386	NOZZLE SUPPORT K 385/386	SUPPORTO UGELLO K 385/386
* 0217433	GUMMIDICHTUNG 17 X 24 X 2	RUBBER PACKING 17 X 24 X 2	GUARNIZIONE IN GOMMA 17 X 24 X 2
0360211	SECHSKANTMUTTER R 3/8" X 5	HEXAGON NUT R 3/8" X 5	DADO ESAGONALE R 3/8" X 5
* 0620436	DRALLEINSATZ K 388	TWISTING FLAT K 388	PIASTRINE DI TORSIONE K 388
* 0620435	DÜSENKAPPE K 387	CAP K 387	CAPPUCCIO PER UGELLO K 387
0640016	SCHLAUCH SCHWARZ/ROT 3/4"	HOSE BLACK/RED 3/4"	FLESSIBILE ROSSO 3/4"
0233045	SCHLAUCHKLEMME 20 - 32	HOSE CLAMP 20 - 32	COLLARE 20 - 32
* 0621070	Y-STÜCK YS 19	Y-PIECE YS 19	RACCORDO A Y YS 19
0620448	DROSSEL OBEN K 401	UPPER THROTTLE K 401	RIDUTTORE SUPERIORE K 401
* 0620235	DÜSENUNTERSATZ K 235	NOZZLE SUPPORT K 235	SUPPORTO UGELLO K 235
8004008	DREHARMLAGER OBEN	UPPER ROTATING ARM BEARING	CUSCINETTO BRACCIO ROTANTE SUP.
8003886	NACHSPÜLDREHARM OBEN BAUGRUPPE	UPPER ROTATING RINSE ARM BLOCK	BRACCIO ROTANTE SUPERIORE RISCIAQUO COMPL., BLOCCO
0330019	BLECHSCHRAUBE DIN 7981 4,2 X 9,5	SHEET METAL SCREW DIN 7981 4,2 X 9,5	VITE PER LAMIERA DIN 7981 4,2 X 9,5
* 0620394	DREHARMNABE K 373	ROTATING ARM HUB K 373	MOZZO PER BRACCIO ROT. K 373
0620390	NACHSPÜLARM 2, MITTEL K 308	FINAL RINSE ARM 2, MEDIUM K 308	BRACCIO DI RISCIAQUO 2 MEDIO, K 308
0620391	NACHSPÜLARM 3, KURZ K 309	FINAL RINSE ARM 3, SHORT K 309	BRACCIO DI RISCIAQUO 3 CORTO, K 309
* 0620121	DRALLEINSATZ K 121	TWISTING FLAT K 121	PIASTRINE DI TORSIONE K 121
* 0620157	NACHSPÜLDÜSENKAPPE K 157	CAP FOR RINSE NOZZLE K 157	CAPPUCCIO PER UGELLO RISCIAQUO, K 157
* 0310010	RÄNDELSCHRAUBE	KNURLED SCREW	VITE ZIGRINATA
* 0620384	SCHRAUBKAPPE K 302	SCREW CAP K 302	CAPPUCCIO PER VITE K 302
8004683	DREHARMWASCHSYSTEM UNTEN BAUGRUPPE	LOWER WASH SYSTEM WITH ROTATING ARM, BLOCK	SISTEMA DI LAVAGGIO CON BRACCIO ROTANTE INFERIORE, BLOCCO
0620387	WASCHARM 3, KURZ, K 305 SCHLITZ INNEN SCHRÄG	WASH ARM 3, SHORT, K 305 SLIT INTERIOR OBLIQUE	BRACCIO DI LAVAGGIO 3, CORTO, K 305, INTAGLIO INTERNO OBLIQUO
0620388	WASCHARM 4, KURZ, K 306 SCHLITZ INNEN GERADE	WASH ARM 4, SHORT, K 306 SLIT INTERIOR STRAIGHT	BRACCIO DI LAVAGGIO 4, CORTO, K 306, INTAGLIO INTERNO DIRITTO
* 8004635	DREHARMNABE	ROTATING ARM HUB	MOZZO PER BRACCIO ROTANTE
8004433	DREHARMLAGER UNTEN KPL. BAUGRUPPE	LOWER ROTATING ARM BEARING COMPL., BLOCK	CUSCINETTO BRACCIO ROTANTE INFERIORE COMPL., BLOCCO
8004179	DROSSEL UNTEN	LOWER THROTTLE	RIDUTTORE INFERIORE
0620446	ADAPTER K 400	ADAPTOR K 400	ADATTATORE K 400
8004195	ZENTRIERSTERN 180 LG.	CENTERING DEVICE STAR 180 LG.	STELLA DI CENTRAGGIO 180 LUNGA
0620432	DREHARMLAGER K 384	ROTATING ARM BEARING K 384	CUSCINETTO BRACCIO ROTANTE K 384
* 0401030	O-RING 50 X 1,5	O-RING 50 X 1,5	ANELLO O-RING 50 X 1,5
0336001	HUTMUTTER DIN 1587 - M 4	CAP NUT BRASS DIN 1587 - M 4	DADO A CAPPELLO DIN 1587 - M 4
0620129	SCHLAUCHKRÜMMER K 129	ELBOW-SHAPED HOSE K 129	ANGOLO DI RACCORDO K 129
0640012	SCHLAUCH GRAU 1/2"	HOSE GREY 1/2"	FLESSIBILE GRIGIO 1/2"
0233037	SCHLAUCHKLEMME 16 - 27	HOSE CLAMP 16 - 27	COLLARE 16 - 27
0233046	SCHLAUCHKLEMME 32 - 50	HOSE CLAMP 32 - 50	COLLARE 32 - 50
0640007	SCHLAUCH SCHWARZ 40 X 5	HOSE BLACK 40 X 5	FLESSIBILE NERO 40 X 5
0409000	DICHTUNG 4 X 8 X 1	PACKING 4 X 8 X 1	GUARNIZIONE 4 X 8 X 1
* 0621036	Y-STÜCK YS 13	Y-PIECE YS 13	RACCORDO Y YS 13
0308030	ZYLINDERSCHRAUBE DIN 84 M 4 X 40	PAN HEAD SCREW DIN 84 M 4 X 40	VITE CON TESTA CILINDRICA DIN 84 M 4 X 40

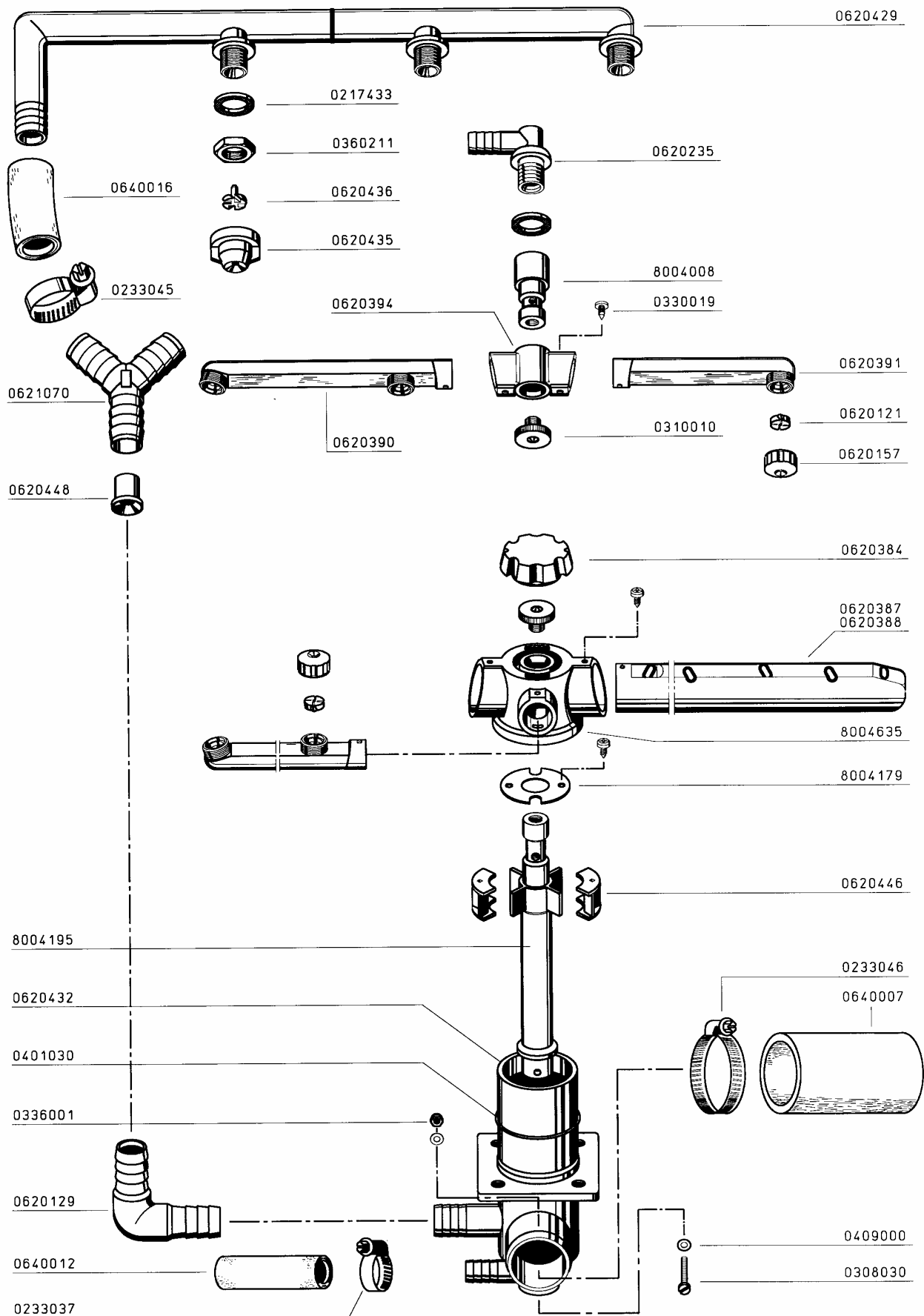

3.13 WASCH- UND NACHSPÜLSYSTEM

3.13 WASHING AND RINSING SYSTEM

3.13 SISTEMA DI LAVAGGIO E RISCIAQUO



EcoStar430-530F E-liste_i
15.10.98/PT

IDENT. NR. CODICE	BEZEICHNUNG	DESIGNATION	DESCRIZIONE
8001815	DREHARMWASCHSYSTEM OBEN BAUGRUPPE	UPPER WASH SYSTEM WITH ROTATING ARM, BLOCK	SISTEMA DI LAVAGGIO CON BRACCIO ROTANTE SUPERIORE, BLOCCO
8001812	DREHARMWASCHSYSTEM UNTEN, BAUGRUPPE	LOWER WASH SYSTEM WITH ROTATING ARM, BLOCK	SISTEMA DI LAVAGGIO CON BRACCIO ROTANTE INFERIORE, BLOCCO
8001814	WASCHARM OBEN/UNTEN BAUGRUPPE	UPPER/LOWER WASH ARM BLOCK	BRACCIO DI LAVAGGIO SUP./INF. BLOCCO
8001816	DREHARMLAGER OBEN BAUGRUPPE	UPPER ROTATING ARM BEARING BLOCK	CUSCINETTO BRACCIO ROTANTE SUPERIORE COMPL., BLOCCO
8001817	DREHARMLAGER UNTEN BAUGRUPPE	LOWER ROTATING ARM BEARING BLOCK	CUSCINETTO BRACCIO ROTANTE INFERIORE COMPL., BLOCCO
* 0620384	SCHRAUBKAPPE K 302	SCREW CAP K 302	CAPPUCCIO PER VITE K 302
* 0310010	RÄNDELSCHRAUBE	KNURLED SCREW	VITE ZIGRINATA
0330019	BLECHSCHRAUBE DIN 7981 4,2 X 9,5	SHEET METAL SCREW DIN 7981 4,2 X 9,5	VITE PER LAMIERA DIN 7981 4,2 X 9,5
* 0620380	DREHARMNABE K 300	ROTATING ARM HUB K 300	MOZZO PER BRACCIO ROT. K 300
0620385	WASCHARM 1, LANG, K 303 SCHLITZ INNEN SCHRÄG	WASH ARM 1, LONG, K 303 SLIT INTERIOR OBLIQUE	BRACCIO DI LAVAGGIO 1, LUNGO, K 303, INTAGLIO INTERNO OBLIQUO,
0620386	WASCHARM 2, LANG, K 304 SCHLITZ INNEN GERADE	WASH ARM 2, LONG, K 304 SLIT INTERIOR STRAIGHT	BRACCIO DI LAVAGGIO 2, LUNGO, K 304, INTAGLIO INTERNO OBLIQUO,
* 0620157	NACHSPÜLDÜSENKAPPE K 157	CAP FOR RINSE NOZZLE K 157	CAPPUCCIO PER UGELLO RISCIAQUO, K 157
* 0620121	DRALLEINSATZ K 121	TWISTING FLAT K 121	PIASTRINE DI TORSIONE K 121
0620389	NACHSPÜLARM 1, LANG K 307	FINAL RINSE ARM 1, LONG K 307	BRACCIO DI RISCIAQUO 1, LUNGO K 307
0620390	NACHSPÜLARM 2, MITTEL K 308	FINAL RINSE ARM 2, MEDIUM K 308	BRACCIO DI RISCIAQUO 2 MEDIO, K 308
8004195	ZENTRIERSTERN 180 LG.	CENTERING DEVICE STAR 180 LG.	STELLA DI CENTRAGGIO 180 LUNGA
0620383	ZENTRIERSTERN 108 LANG	CENTERING DEVICE STAR 108 LG	STELLA DI CENTRAGGIO 108 LUNGA
0620381	ZENTRIERSTERN 180 LANG	CENTERING DEVICE STAR 180 LG	STELLA DI CENTRAGGIO 180 LUNGA
0620288	DREHARMLAGER OBEN	UPPER ROTATING ARM BEARING	CUSCINETTO BRACCIO ROTANTE SUP.
0620285	DREHARMLAGER UNTEN	LOWER ROTATING ARM BEARING	CUSCINETTO BRACCIO ROTANTE INF.
* 0401030	O-RING 50 X 1,5	O-RING 50 X 1,5	ANELLO O-RING, 50 X 1,5
0336001	HUTMUTTER DIN 1587 - M 4	CAP NUT DIN 1587 - M 4	DADO A CAPPELLO DIN 1587 - M 4
0409000	DICHTUNG 4 X 8 X 1	PACKING 4 X 8 X 1	GUARNIZIONE 4 X 8 X 1
0308030	ZYLINDERSCHRAUBE DIN 84 - M 4 X 40	PAN HEAD SCREW DIN 84 - M 4 X 40	VITE CON TESTA CILINDRICA DIN 84 M 4 X 40
0233046	SCHLAUCHKLEMME 32 - 50	HOSE CLAMP 32 - 50	COLLARE 32 - 50
8003919	SCHLAUCH KLARSICHT, OBEN 35 X 5 X 340	UPPER TRANSPARENT HOSE 35 X 5 X 340	FLESSIBILE TRASPARENTE, SOPRA 35 X 5 X 340
8003918	SCHLAUCH KLARSICHT, UNTEN 35 X 5 X 65	LOWER TRANSPARENT HOSE 35 X 5 X 65	FLESSIBILE TRASPARENTE, SOTTO 35 X 5 X 65
0233037	SCHLAUCHKLEMME 16 - 27	HOSE CLAMP 16 - 27	COLLARE 16 - 27
0640012	SCHLAUCH GRAU 1/2"	HOSE GREY 1/2"	FLESSIBILE GRIGIO GRIS 1/2"
* 0621036	Y-STÜCK YS 13	Y-PIECE YS 13	RACCORDO A Y YS 13
8004878	STEIGROHR KPL. (MIT FREIEM AUSLAUF ODER ECOSTAR 530 F)	ASCENDING PIPE COMPL. (WITH AIR GAP OR ECOSTAR 530 F)	TUBO DI DISTRUBUZIONE CPL. (CON USCITA LIBERA O ECOSTAR 530F)

Änderungen in Ausführung und Konstruktion vorbehalten. * We reserve the right to change execution and construction. * Ci riserviamo i diritti di apportare modifiche d'esecuzione e costruzione.

MEIKO Maschinenbau GmbH & Co., Postfach 2040, D-77652 Offenburg, Tel.: (0781) 203-0, Fax.: (0781) 203-274

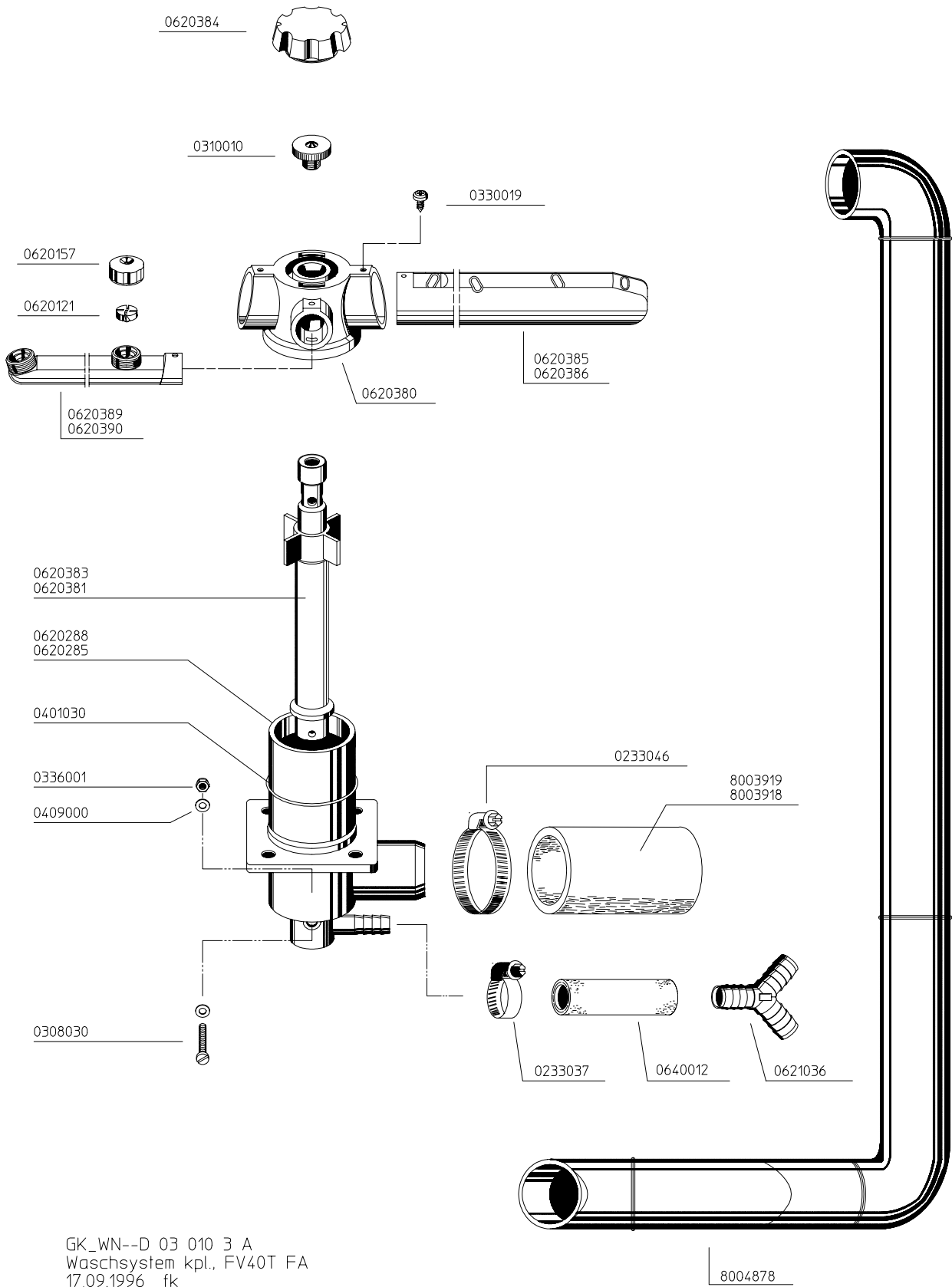

GK_WN--D 03 010 3 A
 Waschsystem kpl., FV40T FA
 17.09.1996 fk

4.8 MAGNETVENTIL

4.8 SOLENOID VALVE

4.8 ELETTROVALVOLA



EcoStar430-530F E-liste_i
15.10.98/PT

IDENT. NR. CODICE	BEZEICHNUNG	DESIGNATION	DESCRIZIONE
* 9000006	MAGNETVENTIL NW 10 ECKAUSFÜHRUNG ECOSTAR 430 F	SOLENOID VALVE NW 10 ANGLED EXECUTION ECOSTAR 430 F	ELETTROVALVOLA NW 10, ESECUZIONE AD ANGOLO ECOSTAR 430 F
* 9505869	MAGNETVENTIL NW 10 GERADE AUSFÜHRUNG ECOSTAR 530 F	SOLENOID VALVE NW 10 LINEAR EXECUTION ECOSTAR 530 F	ELETTROVALVOLA NW 10, ESECUZIONE LINEARE ECOSTAR 530 F
9506227	MENGENREGLER 17 L/ MIN. (NICHT ABGEBILDET)	QUANTITY REGULATOR 17 L/MIN (NOT DISPLAYED)	REGOLATORE DI QUANTITÀ 17 L/MIN (SENZA DISEGNO)
9506228	FILTER (NICHT ABGEBILDET)	FILTER SIEVE F. SOLENOID VALVE (NOT DISPLAYED)	FILTRO PER ELETTROVALVOLA (SENZA DISEGNO)
* 0640012	SCHLAUCH GRAU 1/2"	HOSE GREY 1/2"	FLESSIBILE GRIGIO 1/2"
* 0233043	SCHLAUCHKLEMME 12 - 22	HOSE CLAMP 12 - 22	COLLARE 12 - 22
0621035	T-STÜCK TS 13	T-PIECE TS 13	RACCORDO A T TS 13

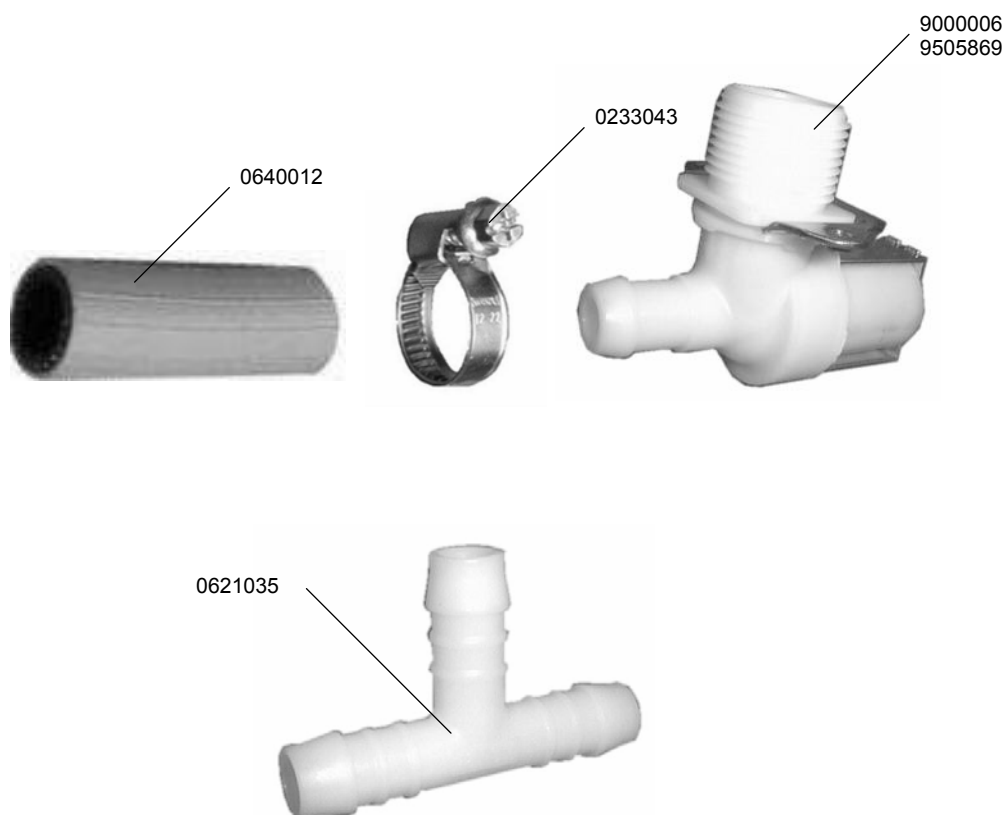

5.1 RÜCKSAUGEVERHINDERER

5.1 REFLUX PREVENTOR

5.1 DISPOSITIVO DI NON RITORNO



EcoStar430-530F E-liste_i
1.8.96/FH

IDENT. NR. CODICE	BEZEICHNUNG	DESIGNATION	DESCRIZIONE
8002731	RÜCKSAUGEVERHINDERER 1/2" KPL. (OHNE EW)	REFLUX PREVENTOR 1/2" COMPL. (WITHOUT EW)	DISPOSITIVO DI NON RITORNO 1/2" COMPL. (SENZA EW)
8002732	RÜCKSAUGEVERHINDERER 1/2" KPL. (MIT EW)	REFLUX PREVENTOR 1/2" COMPL. (WITH EW)	DISPOSITIVO DI NON RITORNO 1/2" COMPL. (CON EW)
* 0620334	RÜCKSAUGEVERHINDERER K 333	REFLUX PREVENTOR K 333	DISPOSITIVO DI NON RITORNO K 333
0340027	UNTERLEGSCHLEIBE DIN 522 - 5,8 X 11 X 1	WASHER DIN 522 - 5,8 X 11 X 1	RONDELLA DIN 522 - 5,8 X 11 X 1
0337001	SECHSKANTMUTTER SELBST- SICHERND DIN 985 - M 5	HEXAGON NUT SELFFIXING DIN 985 - M 5	DADO DIN 985 - M 5
0640012	SCHLAUCH GRAU 1/2"	HOSE GREY 1/2"	FLESSIBILE GRIGIO 1/2"
0233070	1-OHR-KLEMME	1-EAR CLAMP	COLLARE AD UN ORECCHIO
* 0620342	SCHLAUCHANSCHLUSS EINFACH K 340	HOSE CONNECTION SIMPLE K 340	COLLEGAMENTO FLESSIBILE SEMPLICE K 340
* 0620343	SCHLAUCHANSCHLUSS DOPPELT K 341 (MIT EW)	HOSE CONNECTION DOUBLE K 340 (WITH EW)	COLLEGAMENTO FLESSIBILE DOPPIO K 340 (CON EW)
* 0217433	GUMMIDICHTUNG 17 X 24 X 2	RUBBER PACKING 17 X 24 X 2	GUARNIZIONE IN GOMMA 17X24X2
0360211	SECHSKANTMUTTER R 3/8" X 5	HEXAGON NUT R 3/8" X 5	DADO R 3/8" X 5

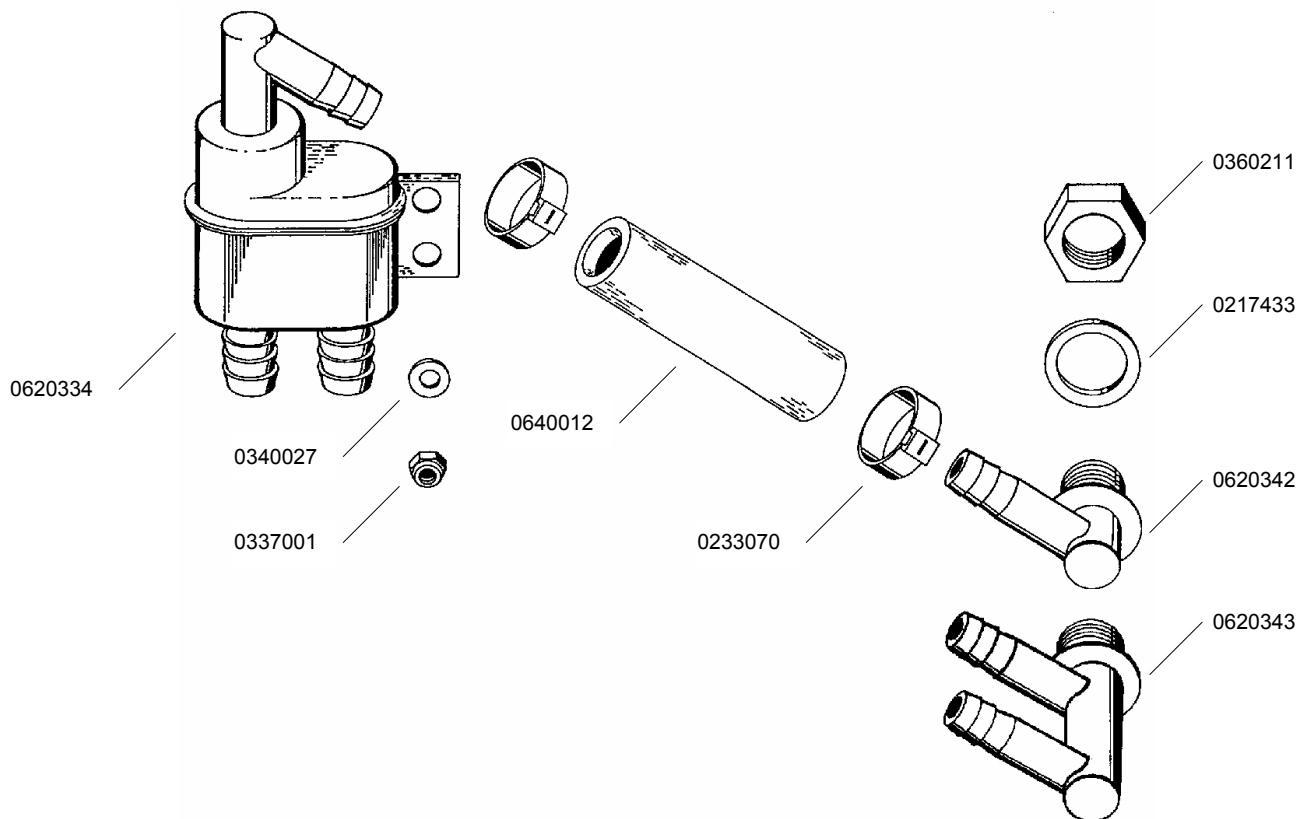

6.3 NIVEAUREGELUNG

6.3 LEVEL CONTROL

6.3 REGOLAZIONE DI LIVELLO



EcoStar430-530F E-liste_i
1.7.97/PT

IDENT. NR. CODICE	BEZEICHNUNG	DESIGNATION	DESCRIZIONE
* 0130026	NIVEAUSCHALTER 40/15	LEVEL SWITCH 40/15	REGOLAZIONE DI LIVELLO 40/15
* 9500044	DRAHTSCHLAUCHKLEMME SILBER 7,8-8,3 MM	HOSE WIRE CLAMP SILVER 7,8-8,3 MM	COLLARE 7,8-8,3 MM
* 0260006	SCHLAUCH KLARSICHT 5 X 1,5	HOSE TRANSPARENT 5 X 1,5	FLESSIBILE TRASPARENTE 5 X 1,5
0431028	KNICKSICHERUNGSFEDER	SAFETY SPRING	MOLLA DI SICUREZZA
* 9500045	DRAHTSCHLAUCHKLEMME GELB 8,8-9,3 MM	HOSE WIRE CLAMP YELLOW 8,8-9,3 MM	COLLARE GIALLO 8,8-9,3 MM
* 0233082	1-OHR-KLEMME 19,5 RER	1-EAR CLAMP 19,5 RER	COLLARE A UN ORECCHIO 19,5 RER
* 0650001	GUMMISTUTZEN	RUBBER SOCKET	PEZZO IN GOMMA
* 0620244	LUFTFALLE K 244	AIR TRAP K 244	CAMERA COMPRESSIONE ARIA K 244

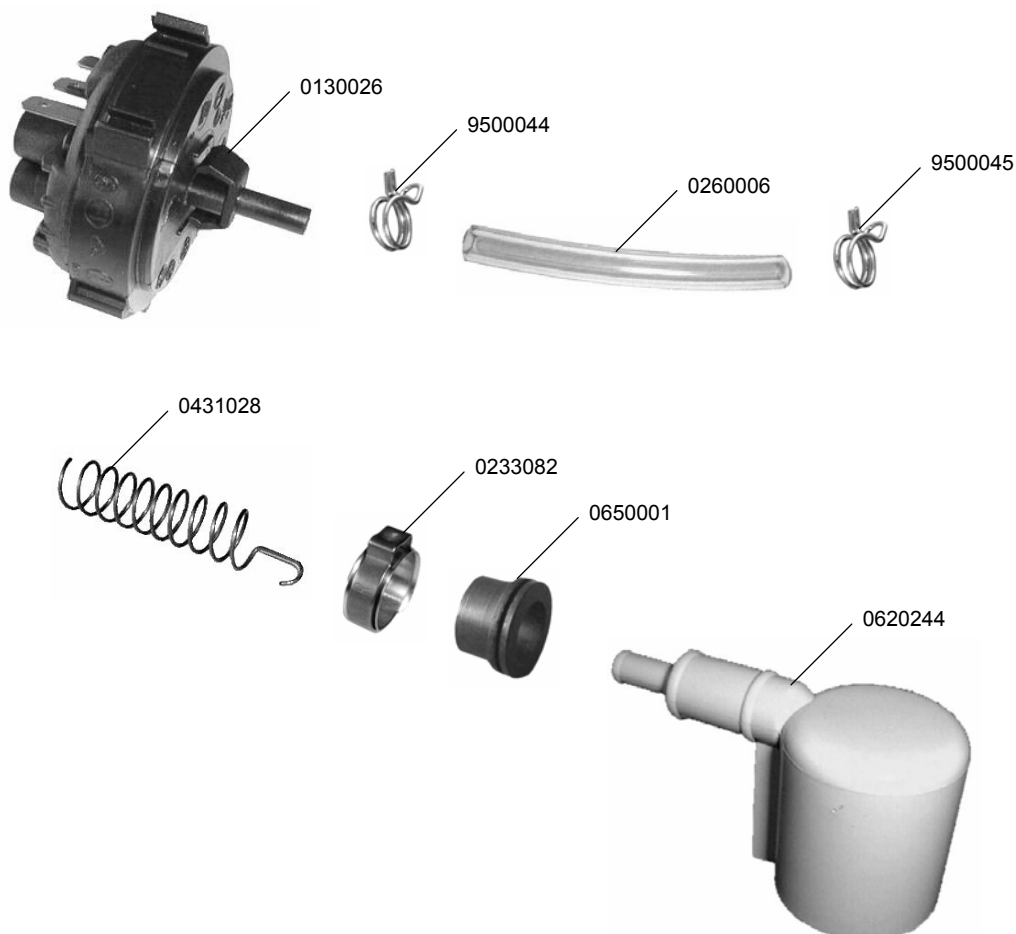

8.20 EINBAUBOILER

8.20 INCORPORATED BOILER

8.20 BOILER INCORPORATO



EcoStar430-530F E-liste_i
01.11.98/PT

IDENT. NR. CODICE	BEZEICHNUNG	DESIGNATION	DESCRIZIONE
9000271	EINBAUBOILER KPL. 3 KW, ECOSTAR 430 F	INCORPORATED BOILER COMPL. 3 KW, ECOSTAR 430 F	BOILER INCORPORATO COMPL. 3 KW, ECOSTAR 430 F
9000270	EINBAUBOILER KPL. 4,5 KW, ECOSTAR 530 F	INCORPORATED BOILER COMPL. 4,5 KW, ECOSTAR 530 F	BOILER INCORPORATO COMPL. 4,5 KW, ECOSTAR 530 F
9505183	EINBAUBOILERGEHÄUSE ABGEPRESST, ECOSTAR 430 F	BOILER HOUSING TESTED UNDER PRESSURE, ECOSTAR 430 F	CARCASSA BOILER COLLAUDATO SOTTO PRESSIONE, ECOSTAR 430 F
9505184	EINBAUBOILERGEHÄUSE ABGEPRESST, ECOSTAR 530 F	BOILER HOUSING TESTED UNDER PRESSURE, ECOSTAR 530 F	CARCASSA BOILER COLLAUDATO SOTTO PRESSIONE, ECOSTAR 530 F
* 9502526	TEMPERATURBEGRENZER	TEMPERATURE LIMITER	LIMITATORE DI TEMPERATURA 105 GRADI
* 0108037	TEMPERATURREGLER	THERMO CONTROL	REGOLATORE DI TEMPERATURA
* 9504228	TOPFFLANSCHHEIZKÖRPER 3 KW, 230/400 V	FLANGE HEATING ELEMENT 3 KW, 230/400 V	RESISTENZA A FLANGIA 3 KW, 230/400 V
* 9504234	TOPFFLANSCHHEIZKÖRPER 4,5 KW, 230/400 V	FLANGE HEATING ELEMENT 4,5 KW, 230/400 V	RESISTENZA A FLANGIA 4,5 KW, 230/400 V
* 0101176	HEIZKÖRPERDICHTUNG 58 X 45 X 6	PACKING F.HEATING ELEMENT 58 X 45 X 6	GUARNIZIONE DI RESISTENZA 58 X 45 X 6
0337001	SECHSKANTMUTTER SELBST- SICHERND DIN 985 - M 5	HEXAGON NUT SELFFIXING DIN 985 - M 5	DADO ESAGONALE DIN 934 - M 5
0101183	SPANNBRÜCKE	GRIPPING YOKE	PONTE DI TENSIONE
* 0640012	SCHLAUCH GRAU 1/2"	HOSE GREY 1/2"	FLESSIBILE GRIGIO 1/2"
* 0233037	SCHLAUCHKLEMME 16 - 27	HOSE CLAMP 16 - 27	COLLARE 16 - 27

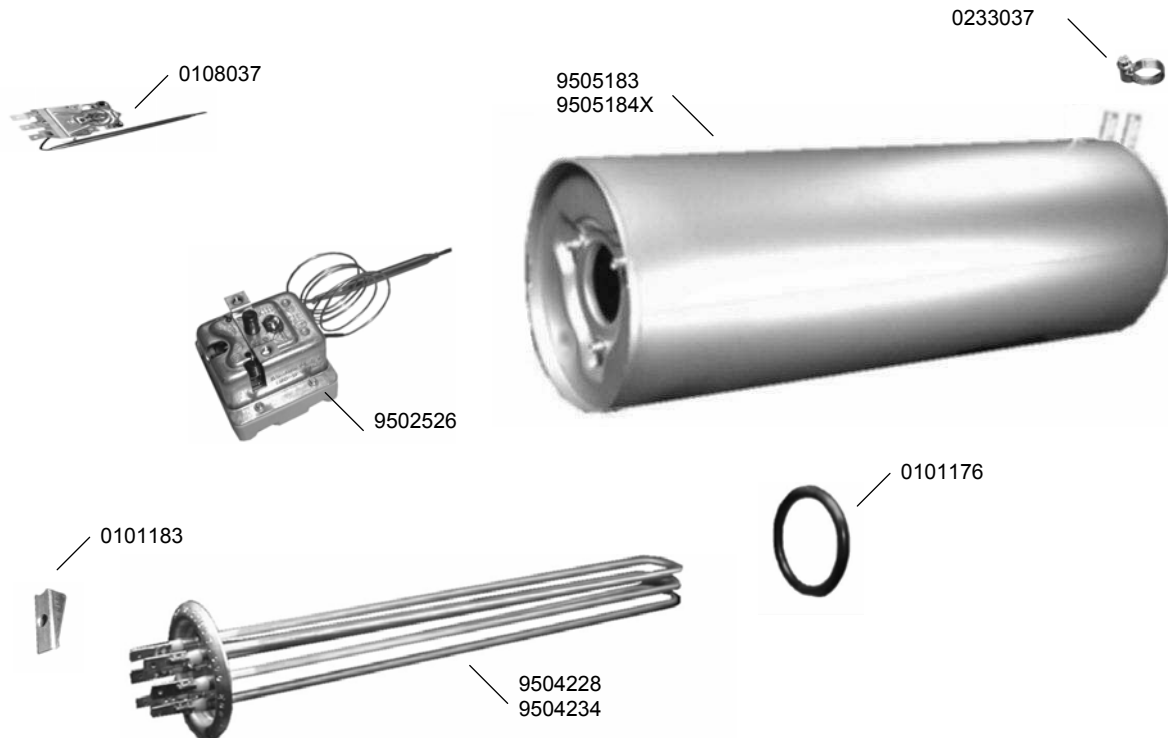

9.1 TANKHEIZUNG

9.1 TANK HEATING

9.1 RISCALDAMENTO DELLA VASCA



EcoStar430-530F E-liste_i
1.4.98/BRD

IDENT. NR. CODICE	BEZEICHNUNG	DESIGNATION	DESCRIZIONE
* 0101152	HEIZKÖRPER 2 KW, 230 V	HEATING ELEMENT 2 KW, 230 V	RESISTENZA 2 KW, 230 V
* 0101175	HEIZKÖRPERDICHTUNG	HEATING ELEMENT PACKING	GUARNIZIONE PER RESISTENZA
* 0108040	GUMMIMANSCHETTE	RUBBER PACKING	PEZZO IN GOMMA
* 0108047	TEMPERATURREGLER 1 KONTAKT	THERMOSTAT, 1 CONTACT	REGOLATORE DI TEMPERATURA 1 CONTATTO
* 0108053	TEMPERATURFÜHLER	TEMPERATURE PROBE	LIMITATORE DI TEMPERATURA
* 0108043	TEMPERATURBEGRENZER	TEMPERATURE LIMITER	SONDA DI TEMPERATURA R1/4"

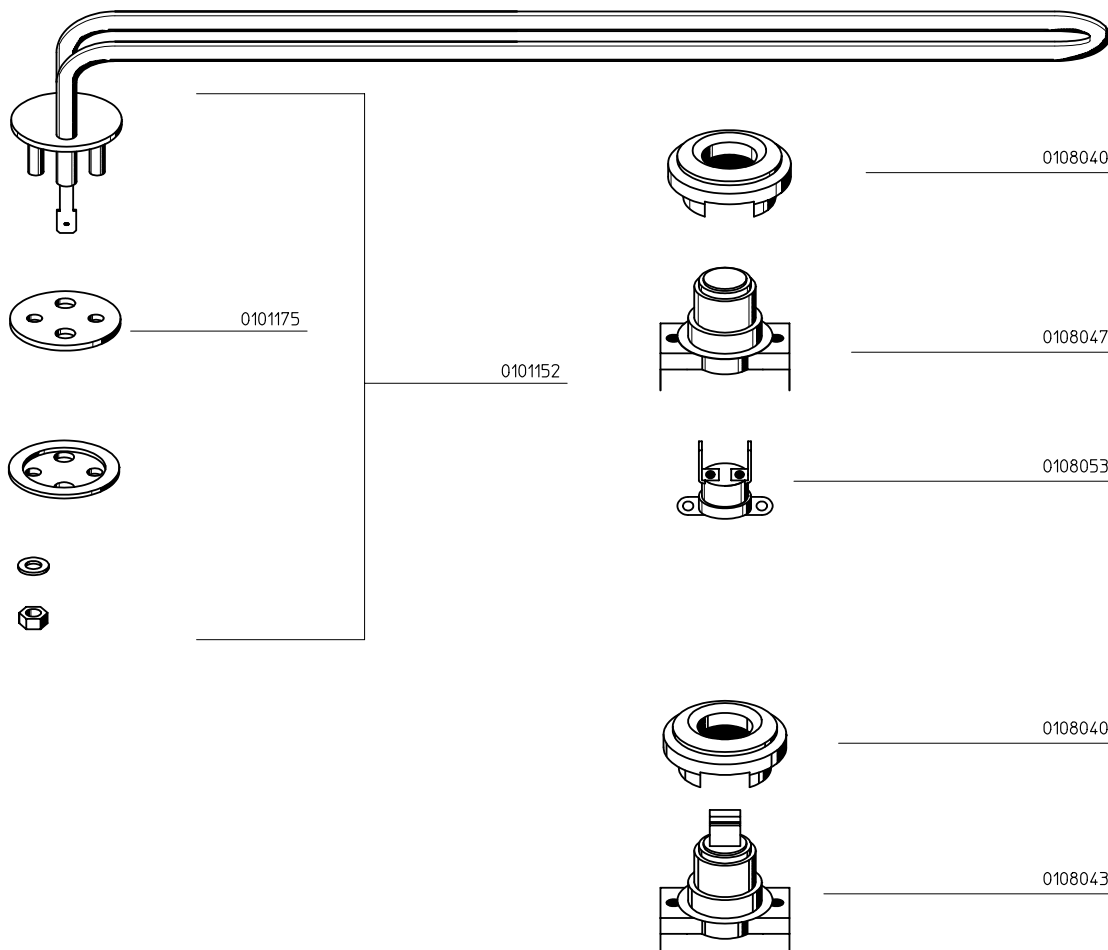

10.5 KLARSPÜLERDOSIERGERÄT

10.5 RINSE AID DOSING UNIT

10.5 DOSATORE DEL BRILLANTANTE



EcoStar430-530F E-liste_i
1.10.96/FH

IDENT. NR. CODICE	BEZEICHNUNG	DESIGNATION	DESCRIZIONE
* 0260070	KLARSPÜLERDOSIERGERÄT N 6	RINSE AID DOSING UNIT N 6	DOSATORE DEL BRILLANTANTE N 6
0260071	BEFESTIGUNGSLASCHE	FIXING LINK	COLLARE DI FISSAGGIO
0260072	SCHRAUBE EJOT-PT KB 40 X 8	SCREW EJOT-PT KB 40 X 8	VITE EJOT-PT KB 40 X 8
* 0260049	EINSCHRAUBWINKEL M 10 X 1	INSERT ANGLE M 10 X 1	RACCORDO D'AVVITAMENTO M10X1
0233036	SCHLAUCHKLEMME 10 - 16	HOSE CLAMP 10 - 16	COLLARE 10 - 16
0640017	SCHLAUCH SCHWARZ 6 X 4,5	HOSE BLACK 6 X 4,5	FLESSIBILE NERO 6 X 4,5
0260052	DRUCKANSCHLUSS M 10 X 1	DELIVERY CONNECTION M 10 X 1	RACCORDO DI COLLEGAMENTO M 10 X 1
* 0260051	O-RING 16 X 2	O-RING 16 X 2	ANELLO O-RING 16 X 2
* 0260053	O-RING 8 X 2	O-RING 8 X 2	ANELLO O-RING 8 X 2
0175006	SCHLAUCHKLEMME 9 - 10	HOSE CLAMP 9 - 10	COLLARE 9 - 10
0260007	SCHLAUCH KLARSICHT 6 X 1,5	HOSE TRANSPARENT 6 X 1,5	FLESSIBILE TRASPARENTE 6X1,5
* 0113098	MAGNETVENTILFILTERSIEB	FILTER FOR SOLENOID VALVE	FILTRO PER ELETTROVALVOLA
8003830	KLARSPÜLERBEHÄLTER K 376	RINSE AID CONTAINER K 376	CONTENITORE PER BRILLANTANTE K 376
0233078	1-OHR-KLEMME 10,0 RER	1-EAR CLAMP 10,0 RER	COLLARE 1 ORECCHIO 10,0 RER
* 0260090	KORBFILTER	BASKET FILTER	FILTRO A CESTELLO

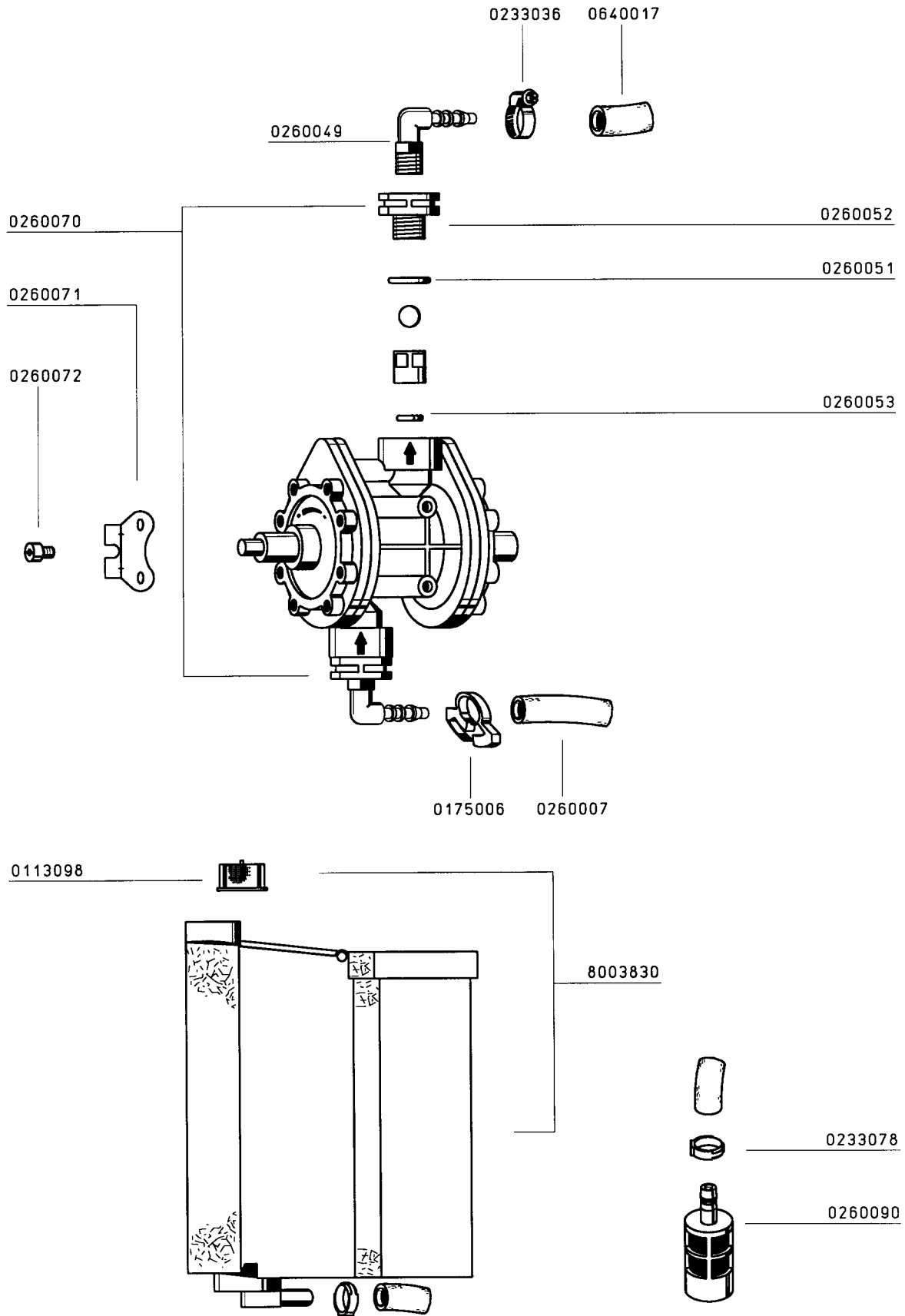

11.22 ELEKTRONIKSTEUERUNG

11.22 ELECTRONIC CONTROL

11.22 COMANDO ELETTRONICO



EcoStar430-530F E-liste_j
1.12.98/FH

IDENT. NR. CODICE	BEZEICHNUNG	DESIGNATION	DESCRIZIONE
* 9503064	FOLIENASTATUR ECOSTAR 430 F	SENSOR TOUCH PANEL ECOSTAR 430 F	TASTIERA ELETTRONICA ECOSTAR 430 F
* 9503065	FOLIENASTATUR ECOSTAR 530 F NICHT ABGEBILDET	SENSOR TOUCH PANEL ECOSTAR 530 F NOT DISPLAYED	TASTIERA ELETTRONICA ECOSTAR 530 F SENZA DISEGNO
* 0124187	STEUERPLATINE SPÜL 3 (MIT LP)	CONTROL BOARD SPUEL 3 (WITH DRAIN PUMP)	PIASTRA DI COMANDO SPUEL 3 (CON POMPA DI SCARICO)
* 9505865	RECHNER SPÜL 3, P 64/5 120" / 160"	CHIP SPUEL 3, P 64/5 120" / 160"	MICROPROCESSORE SPUEL 3, P 64/5 120" / 160"
* 9505866	RECHNER SPÜL 3, P 65/5 120" / 270"	CHIP SPUEL 3, P 65/5 120" / 270"	MICROPROCESSORE SPUEL 3, P 65/5 120" / 270"
* 9503170	FLACHBANDKABEL M. STECKER 10 POL. 0,8 M ECOSTAR 530 F	RIBBON CABLE WITH PLUG 10 POL. 0,8 M ECOSTAR 530 F	CAVO PIATTO CON SPINA 10 POLI 0,8 M ECOSTAR 530 F
* 9503172	FLACHBANDKABEL M. STECKER 10 POL. 1,8 M ECOSTAR 430 F	RIBBON CABLE WITH PLUG 10 POL. 1,8 M ECOSTAR 430 F	CAVO PIATTO CON SPINA 10 POLI 1,8 M ECOSTAR 430 F
0175553	ABSTANDSHALTER	SPREADER	DISTANZIATORE
0175554	ABSTANDSHALTER ERDEND	SPREADER GROUNDED	DISTANZIATORE CON TERRA
0122070	MAGNETSCHALTER	MAGNET SWITCH	INTERRUTTORE MAGNETICO



9503064
9503065

9503172
9503170

9505865
9505866

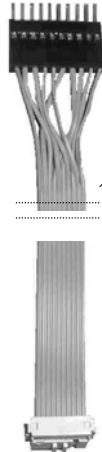

0124187

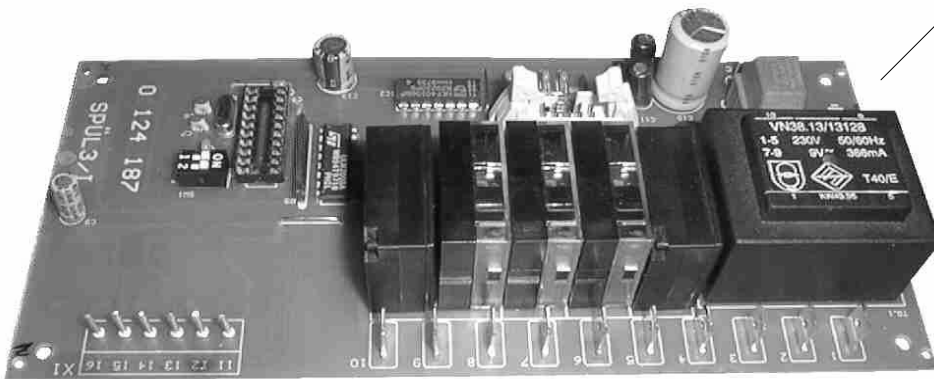

0175554
0175553



0122070

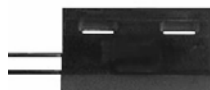

12.8 ELEKTROTEILE

12.8 ELECTRICAL PARTS

12.8 RICAMBI ELETTRICI



EcoStar430-530F E-liste_j
1.12.98/FH

IDENT. NR. CODICE	BEZEICHNUNG	DESIGNATION	DESCRIZIONE
0153288	ENDHALTER	FINAL HOLDER	SUPPORTO FINALE
0153071	ABSCHLUß- UND ZWISCHEN- PLATTE 2,5QMM GRAU	BINDER END COVER 2,5QMM GREY	PIASTRA COPERCHIO E INTERMEDIO 2,5QMM GRIGIO
0153080	ABSCHLUß- UND ZWISCHEN- PLATTE 4QMM GRAU	BINDER END COVER 4QMM GREY	PIASTRA COPERCHIO E INTERMEDIO 4QMM GRIGIO
0153128	ABSCHLUß- UND ZWISCHEN- PLATTE 6QMM GRAU	BINDER END COVER 6QMM GREY	PIASTRA COPERCHIO E INTERMEDIO 6QMM GRIGIO
0153060	KLEMME 3-LEITER 4QMM GRAU	BINDER 3 CONDUCTORS 4QMM GREY	MORSETTIERA 3 CONDUTTORI 4QMM, GRIGIA
0153127	KLEMME 3-LEITER 4QMM BLAU	BINDER 3 CONDUCTORS 4QMM BLUE	MORSETTIERA 3 CONDUTTORI 4QMM, BLU
0153132	KLEMME 3-LEITER 4QMM GELB/GRÜN	BINDER 3 CONDUCTORS 4QMM YELLOW/GREEN	MORSETTIERA 3 CONDUTTORI 4QMM, GIALLO / VERDE
0153129	KLEMME 3-LEITER 6QMM GRAU	BINDER 3 CONDUCTORS 6QMM GREY	MORSETTIERA 3 CONDUTTORI 6QMM, GRIGIA
0153131	KLEMME 3-LEITER 6QMM BLAU	BINDER 3 CONDUCTORS 6QMM BLUE	MORSETTIERA 3 CONDUTTORI 6QMM, BLU
0153130	KLEMME 3-LEITER 6QMM GELB/GRÜN	BINDER 3 CONDUCTORS 6QMM YELLOW/GREEN	MORSETTIERA 3 CONDUTTORI 6QMM, GIALLO / VERDE
0153042	KLEMME 4-LEITER 2,5QMM GRAU	BINDER 4 CONDUCTORS 2,5QMM GREY	MORSETTIERA 4 CONDUTTORI 2,5QMM, GRIGIA
9505881	KLEMME 4-LEITER 2,5QMM BLAU	BINDER 4 CONDUCTORS 2,5QMM BLUE	MORSETTIERA 4 CONDUTTORI 2,5QMM BLU
9505882	KLEMME 4-LEITER 2,5QMM GELB/GRÜN	BINDER 4 CONDUCTORS 2,5QMM YELLOW/GREEN	MORSETTIERA 4 CONDUTTORI 2,5QMM GIALLO / VERDE
0153091	QUERBRÜCKER 4QMM	CROSS BRIDGE 4QMM	CONTATTO A PONTE 4QMM
0153126	QUERBRÜCKER 6QMM	CROSS BRIDGE 6QMM	CONTATTO A PONTE 6QMM
0153054	SICHERUNGSKLEMME	SAFETY CLAMP	MORSETTIERA DI SICUREZZA
* 0145013	FEINSICHERUNG 4A MITTELTRÄGE 5 X 20	FINE-WIRE FUSE 4A TIME LAGGED 5 X 20	FUSIBILE FINE 4A AZIONE RITARDATA 5 X 20
* 0145000	FEINSICHERUNG 10A MITTELTRÄGE 5 X 20	FINE-WIRE FUSE 10A TIME LAGGED 5 X 20	FUSIBILE FINE 10A AZIONE RITARDATA 5 X 20
* 0135200	SCHÜTZ B6-30-10 230 V 40/60 HZ	CONTACTOR B6-30-10 230 V 40/60 HZ	CONTATTATORE B6-30-10 230 V 40/60 HZ
* 0135209	SCHÜTZ B6-30-01 230 V 40/60 HZ	CONTACTOR B6-30-01 230 V 40/60 HZ	CONTATTATORE B6-30-01 230 V 40/60 HZ
* 0135204	SCHÜTZ B9-30-01 230 V 50 HZ	CONTACTOR B9-30-01 230 V 50 HZ	CONTATTATORE B9-30-01 230 V 50 HZ
* 0135202	SCHÜTZ B12-30-01 230 V 50 HZ	CONTACTOR B12-30-01 230 V 50 HZ	CONTATTATORE B12-30-01 230 V 50 HZ
* 0124217	SANFTANLAUFSTEUERUNG SAS 1	SOFT START CONTROL SAS 1	COMANDO CON PARTENZA SOFT SAS 1
AUTOMATEN MIT VARIOTRONIC:		MACCHINE CON VARIOTRONIC:	
0530114	FREQUENZUMRICHTER 605	FREQUENCY CONVERTER 605	COVERTER DI FREQUENZA 3G3EV
9507084	FREQUENZUMRICHTER 3G3EV	FREQUENCY CONVERTER 3G3EV	FILTRO RETE 3G3EV-PFI1015-E

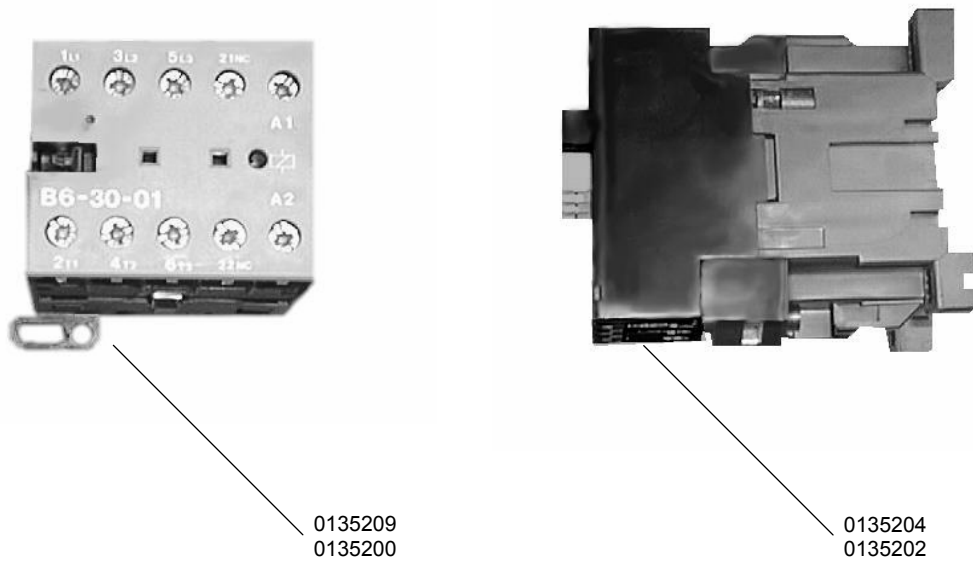
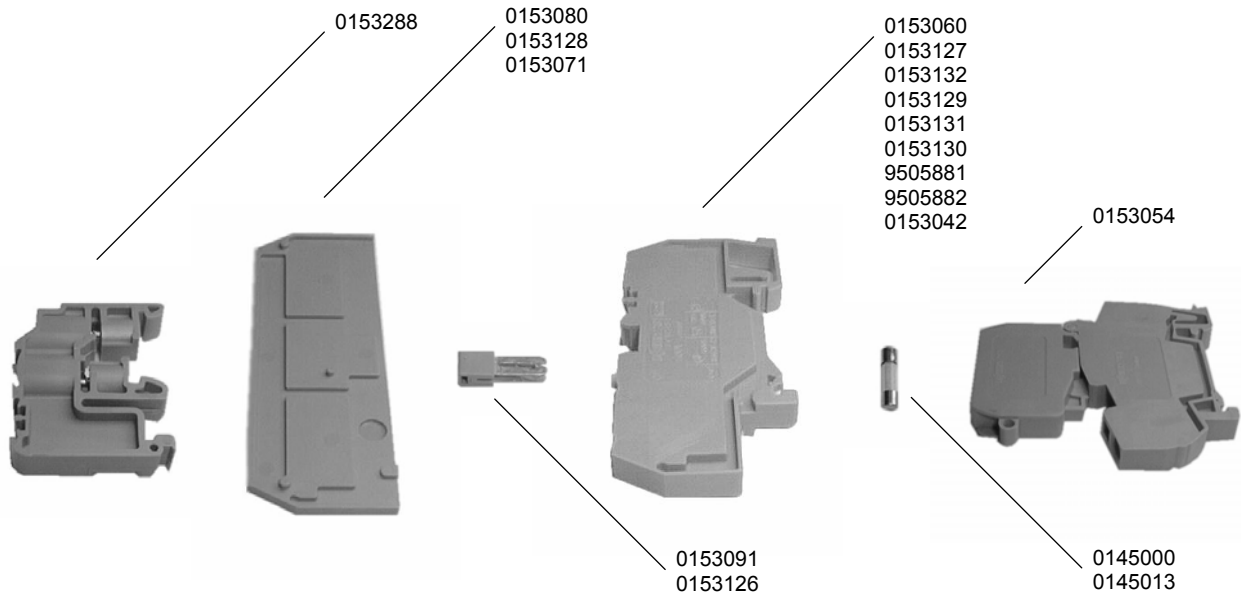

13.17 BAUGRUPPEN/EINZELTEILE

13.17 COMPONENT BLOCKS/PARTS

13.17 BLOCCHI DI COMPONENTI / PEZZI



EcoStar430-530F E-liste_i
1.11.98/PT

IDENT. NR. CODICE	BEZEICHNUNG	DESIGNATION	DESCRIZIONE
8003678	KLAPPTÜR KPL.	FLAP DOOR COMPL.,	SPORTELLO RIBALTABILE COMPL.,
8003681	TÜRLAGER RECHTS KPL.	DOOR BEARING, RIGHT, COMPL.	CUSCINETTO DESTRO PER SPORTELLO COMPL.
8003600	TÜRLAGER LINKS KPL.	DOOR BEARING, LEFT, COMPL.	CUSCINETTO SINISTRO PER SPORTELLO COMPL.
8003677	ROLLE KURZ, Ø 10 X 3	ROLLER SHORT, Ø 10 X 3	RULLO CORTO, Ø 10 X 3
8003675	ROLLE LANG, Ø 10 X 9,5	ROLLER LONG, Ø 10 X 9,5	RULLO LUNGO, Ø 10 X 9,5
0430025	ZUGFEDER 14,5 X 81	TENSION SPRING 14,5 X 81	MOLLA DI TRAZIONE 14,5 X 81
8005632	ABDECKUNG	COVER	RIVESTIMENTO
9501038	SEITENVERKLEIDUNG RECHTS	SIDE CLADDING, RIGHT	RIVESTIMENTO LATERALE DESTRO
9501035	SEITENVERKLEIDUNG LINKS	SIDE CLADDING, LEFT	RIVESTIMENTO LATERALE SINISTRO
9506492	BODENBLECH	BOTTOM SHEET	LAMIERA BASE
8003825	FRONTBLECH	FRONT SHEET	LAMIERA FRONTALE
0460035	KUNSTSTOFF-FUSS	PLASTIC FOOT	PIEDINO
9502904	SCHALTERBLENDE	SWITCH BLIND	
9503715	RÜCKWAND	REAR CLADDING	RIVESTIMENTO SCHIENALE
0401017	O-RING Ø 22 X 2,5	O-RING Ø 22 X 2,5	ANELLO O-RING Ø 22 X 2,5
9505088	ABLAUFSCHLAUCH	DISCHARGE HOSE	FLESSIBILE DI SCARICO
9505089	PANZERSCHLAUCH 1/2" X 2000	REINFORCED HOSE 1/2" X 2000	FLESSIBILE RINFORZATO 1/2" X 2000
9503011	SCHLAUCHANSCHLUß FÜR ABWASSER, AUßEN K 453	HOSE CONNECTION FOR WASTE, OUTSIDE K 453	ALLACCIAMENTO FLESSIBILE PER SCARICO ESTERNO K 453
9502991	SCHLAUCHANSCHLUß FÜR ABWASSER, INNEN K 454	HOSE CONNECTION FOR WASTE, INSIDE K 454	ALLACCIAMENTO FLESSIBILE PER SCARICO INTERNO K 454

13.18 BAUGRUPPEN/EINZELTEILE

13.18 COMPONENT BLOCKS/PIECE PARTS

13.18 BLOCCHI DI COMPONENTI / PEZZI



IDENT. NR. CODICE	BEZEICHNUNG	DESIGNATION	DESCRIZIONE
8003984	KLAPPTÜR KPL.	FLAP DOOR COMPL.	SPORTELLO RIBALTABILE COMPL.,
0650080	GUMMILEISTE, TÜRANSCHLAG	TANK DOOR RUBBER	BATTEMENT DE PORTE EN CAOUTCHOUC
8004426	TÜRLAGER RECHTS KPL.	RIGHT DOOR BEARING COMPL.	CUSCINETTO DESTRO PER SPORTELLO COMPL.
8003985	TÜRLAGER LINKS KPL.	LEFT DOOR BEARING COMPL.	CUSCINETTO SINISTRO PER SPORTELLO COMPL.
0620398	ROLLE K 397	ROLLER K 397	RULLO K 397
0435150	SEILHAKEN	ROPE HOOK	GANCIO CORDA
0435151	ZUGSEIL	TRACTION ROPE	CORDA DI TRAZIONE
0430025	ZUGFEDER 14,5 X 81	TENSION SPRING 14,5 X 81	MOLLA DI TRAZIONE 14,5 X 81
8003992	ABDECKUNG	COVER	RIVESTIMENTO RECOUVREMENT
9500693	SEITENVERKLEIDUNG	LATERAL CLADDING	RIVESTIMENTO LATERALE
9500866	BODENBLECH	BOTTOM SHEET	LAMIERA BASE
9505139	FRONTBLECH 1 BEHÄLTER	FRONT SHEET 1 CONTAINER	LAMIERA FRONTALE 1 CONTENITORE
8004434	FRONTBLECH OHNE BEHÄLTER	FRONT SHEET WITHOUT CONTAINER	LAMIERA FRONTALE SENZA CONTENITORE
9505774	SOCKEL 60 HOCH	PLINTH 60 HIGH	ZOCCOLO 60 ALTO
9510685	SOCKEL 120 HOCH	PLINTH 120 HIGH	ZOCCOLO 120 ALTO
9510689	SOCKEL 150 HOCH	PLINTH 150 HIGH	ZOCCOLO 150 ALTO
0460035	KUNSTSTOFF-FUSS	PLASTIC FOOT	PIEDINO
0265021	EINFÜLLTRICHTER	FUNNEL TUBE	IMBUTO DI RIEMPIMENTO
9505088	ABLAUFSCHLAUCH	DISCHARGE HOSE	FLESSIBILE DI SCARICO
9505089	PANZERSCHLAUCH 1/2" X 2000	REINFORCED HOSE 1/2" X 2000	FLESSIBILE RINFORZATO 1/2" X 2000
9503011	SCHLAUCHANSCHLUß FÜR ABWASSER, AUßEN K 453	HOSE CONNECTION FOR WASTE, OUTSIDE K 453	ALLACCIAMENTO FLESSIBILE PER SCARICO ESTERNO K 453
0401017	O-RING Ø 22 X 2,5	O-RING Ø 22 X 2,5	ANELLO O-RING Ø 22 X 2,5
9502991	SCHLAUCHANSCHLUß FÜR ABWASSER, INNEN K 454	HOSE CONNECTION FOR WASTE, INSIDE K 454	ALLACCIAMENTO FLESSIBILE PER SCARICO INTERNO K 454

18.1 LAUGENPUMPE

18.1 DRAIN PUMP

18.1 POMPA DI SCARICO



EcoStar430-530F E-liste_j
1.12.98/FH

IDENT. NR. CODICE	BEZEICHNUNG	DESIGNATION	DESCRIZIONE
* 0535509	LAUGENPUMPE 230 V, 50 HZ	LYE PUMP 230 V, 50 HZ	POMPA DI SCARICO 230 V, 50 HZ
8002263	SAUGSTUTZEN OR 50 H, DV 40 N, DV 40 - 120 T	SUCTION SOCKET OR 50 H, DV 40 N, DV 40 - 120 T	MANICOTTO D'ASPIRAZIONE OR 50 H, DV 40 N, DV 40 - 120 T
8003831	SAUGSTUTZEN FV 20/40/70 T	SUCTION SOCKET FV 20/40/70 T	MANICOTTO D'ASPIRAZIONE FV 20/40/70 T
8004985	SAUGSTUTZEN FV 20/40/70 TFA, ECOSTAR 530 F	SUCTION SOCKET FV 20/40/70 TFA, ECOSTAR 530 F	MANICOTTO D'ASPIRAZIONE FV 20/40/70 TFA, ECOSTAR 530 F HE 2368/70
0620129	SCHLAUCHKRÜMMER K 129	ELBOW-SHAPED HOSE K 129	RACCORDO AD ANGOLO K 129
0233045	SCHLAUCHKLEMME 20 - 32	HOSE CLAMP 20 - 32	COLLARE 20-32
0640026	SCHLAUCH 3/4"	HOSE 3/4"	FLESSIBILE 3/4"
0640045	SPIRALSCHLAUCH 3/4"	SPIRAL HOSE 3/4"	FLESSIBILE A SPIRALE 3/4"
0640037	ABLAUSCHLAUCH	DRAIN HOSE	FLESSIBILE DI SCARICO

