

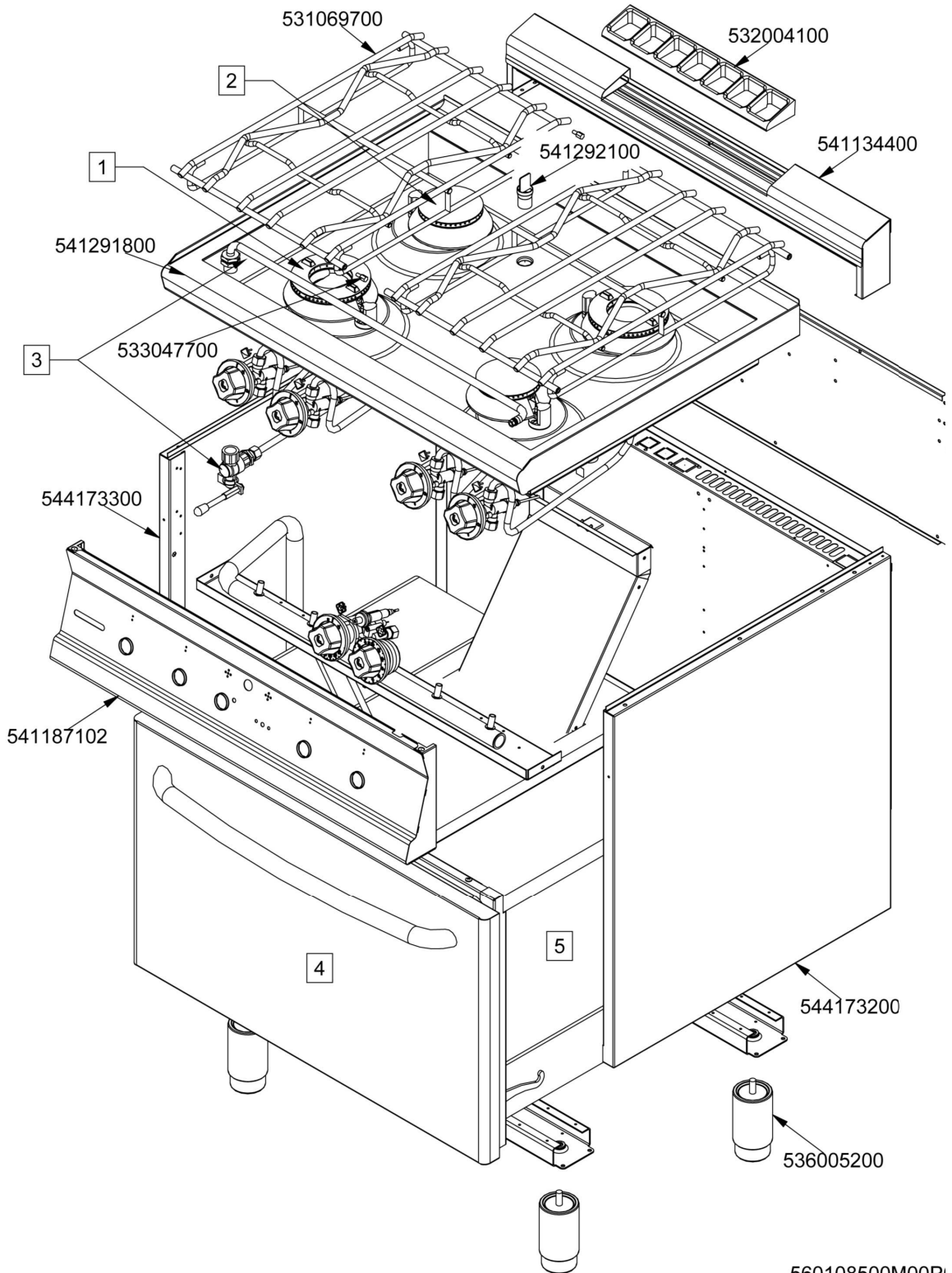

CFA4-78G (SN>=1201<=1604)  
Tav. 560108500M00P00



560108500M00P00



CFA4-78G (SN>=1201<=1604) - CFA4-78G

Codice	Descrizione
531069700	GRIGLIA PCA S70 2F.TOND.
530204100	CODICE IN ELABORAZIONE
541134400	ASS.DIST.S70 BASS.7 8 1 GRI.CX
541292100	ASS.TROPPOPIENO PCA
541291800	ASS.PIANO S70 PCA-7 8G
533047700	DIST.GRI.PORTAPIETRA CW
544173300	FIANCO APP.S70M CF SX
541187102	ASS.CRUSC.S607090 CFA4-98G
544173200	FIANCO APP.S70M CF DX
536005200	PIEDE Ø2" 120-180 M10 INOX
-	-
-	-
-	-
-	-
-	-



COMANDO E BRUCIATORE PCA-G 3UR (SN<=1604)  
Tav. 560101400M00P00

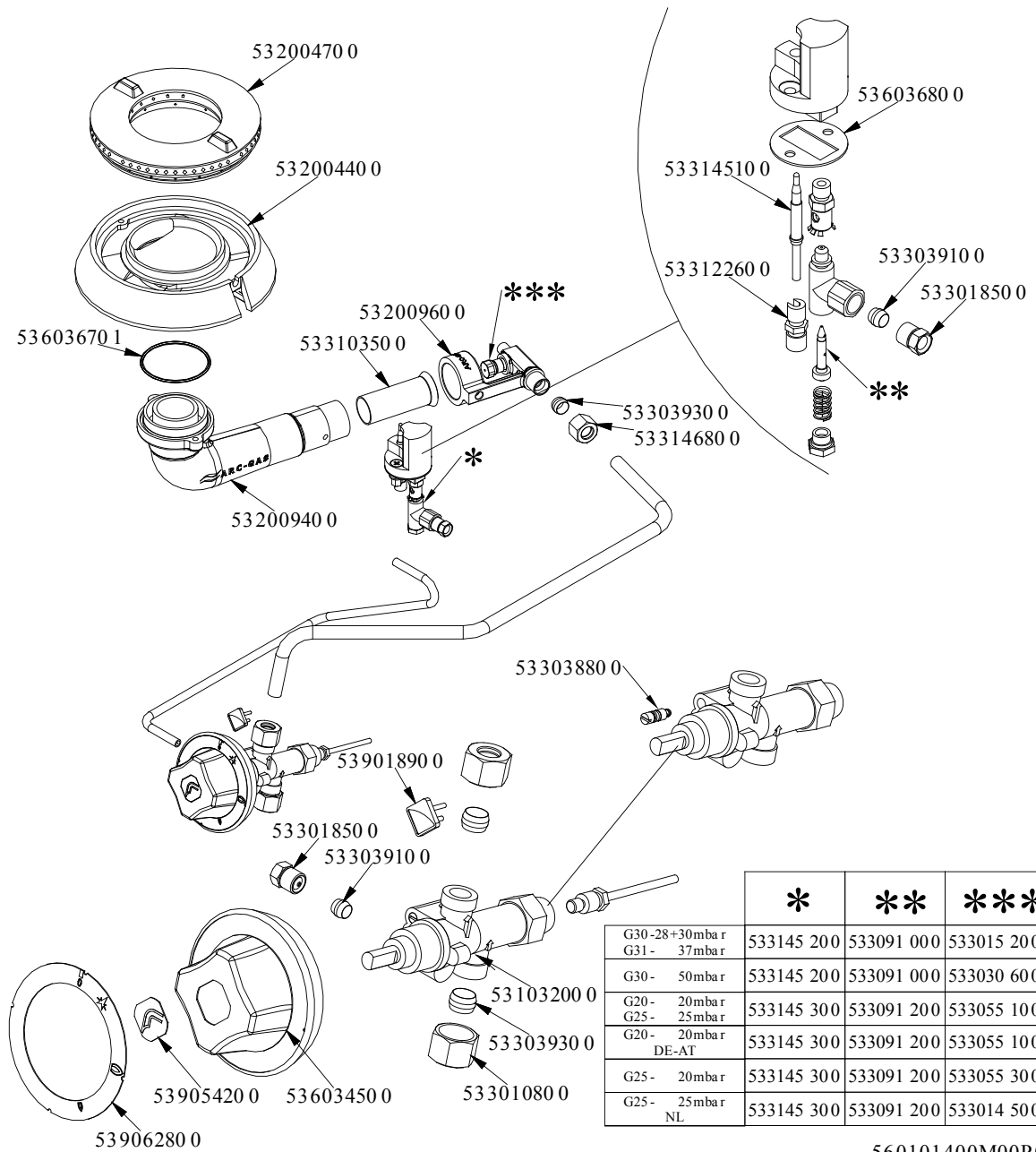

	*	**	***
G30-28+30mbar G31- 37mbar	533145 200	533091 000	533015 200
G30- 50mbar	533145 200	533091 000	533030 600
G20- 20mbar G25- 25mbar	533145 300	533091 200	533055 100
G20- 20mbar DE-AT	533145 300	533091 200	533055 100
G25- 20mbar	533145 300	533091 200	533055 300
G25- 25mbar NL	533145 300	533091 200	533014 500

560101400M00P00



## COMANDO E BRUCIATORE PCA-G 3UR (SN&lt;=1604) - COMPONENTI COMUNI COMA

Codice	Descrizione
532004700	SPARTIF.D.CORONA Ø128 NICH. S70
532004400	CORPO BRU.A1 7,5KW NICH. S70
536036701	GUARNIZ.O-RING BRU.STAGNO PCA
532009600	RACC.PORTAINIETT.VENTURI BRU.A3
533103500	BOCCOLA REG.ARIA Ø22 EST.ALT.57
532009400	VENTURI BRU.A3 8,5KW S90 PCA
536036800	GUARNIZ.PILOTA BRU.STAGNI PCA
533145100	TC G.SPECIALE 0750
533122600	RACC.TERMOC.FRESATO M8X1 M9X1
533039100	BICONO Ø06
533018500	RACC.BIC.Ø06 M10X1
533039300	BICONO Ø10
533146800	DADO ES.X BIC.Ø10 M14X1
533038800	BY-P.RUB.20S-21S Ø075
539018900	INDICE MAN.C/FRECCIA ROSSA
533018500	RACC.BIC.Ø06 M10X1
533039100	BICONO Ø06
531032000	RUB.GAS 21S P.V.BY-P.Ø075
533039300	BICONO Ø10
533010800	DADO ES.X BIC.Ø10 M16X1,5
536034500	MANOP.Ø77 4 P.Ø08X6,5 NERO
539054200	BOLLINO Ø20,3 CR."L" LOTUS R.
539062800	DISC.72.PC-GP R.
533145200	PILOTA STAGNO UG.Ø20
533145300	PILOTA STAGNO UG.Ø35
533091000	UGELLO PILOTA 0100 Ø20 PIL.PC
533091200	UGELLO PILOTA 0100 Ø35 PIL.PC
533015200	INIETTORE CH12X14,0 Ø145
533030600	INIETTORE CH12X14,0 Ø125
533055100	INIETTORE CH12X14,0 Ø215
533055300	INIETTORE CH12X14,0 Ø235
533014500	INIETTORE CH12X14,0 Ø225



COMANDO E BRUCIATORE PCA-G 2R (SN<=1604)  
Tav. 560101300M00P00

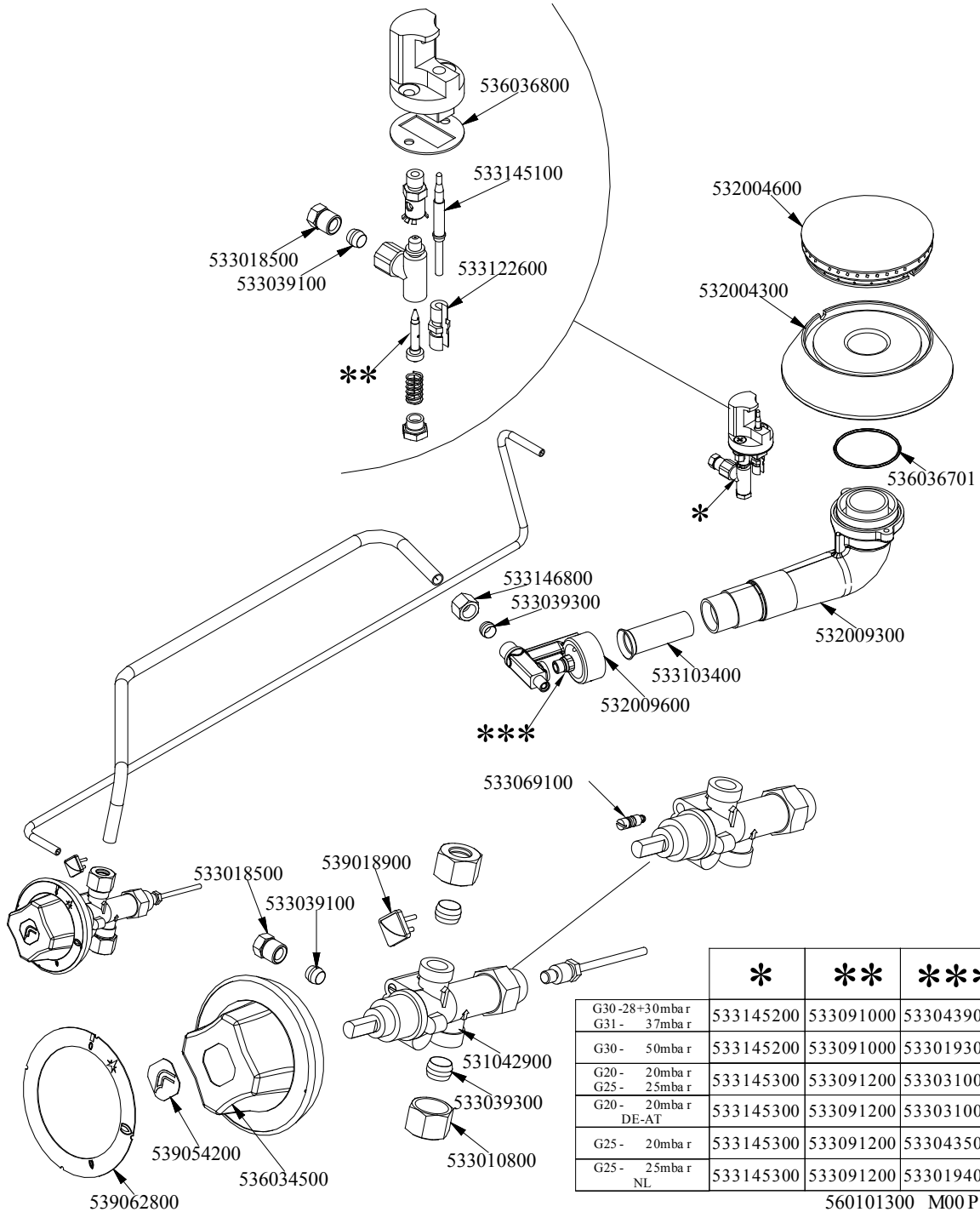

	*	**	***
G30-28+30mbar	533145200	533091000	533043900
G31-37mbar			
G30-50mbar	533145200	533091000	533019300
G20-20mbar	533145300	533091200	533031000
G25-25mbar			
G20-20mbar DE-AT	533145300	533091200	533031000
G25-20mbar	533145300	533091200	533043500
G25-25mbar NL	533145300	533091200	533019400

560101300 M00P00



## COMANDO E BRUCIATORE PCA-G 2R (SN&lt;=1604) - COMPONENTI COMUNI COMAN

Codice	Descrizione
536036800	GUARNIZ.PILOTA BRU.STAGNI PCA
533145100	TC G.SPECIALE 0750
533018500	RACC.BIC.Ø06 M10X1
533039100	BICONO Ø06
533122600	RACC.TERMOC.FRESATO M8X1 M9X1
532004600	SPARTIF.CORONA Ø104 NICH. S70
532004300	CORPO BRU.A1 5,5KW NICH. S70
536036701	GUARNIZ.O-RING BRU.STAGNO PCA
532009300	VENTURI BRU.A3 5,5KW S90 PCA
533146800	DADO ES.X BIC.Ø10 M14X1
533039300	BICONO Ø10
533103400	BOCCOLA REG.ARIA Ø20 EST.ALT.57
532009600	RACC.PORTAINIETT.VENTURI BRU.A3
533069100	BY-P.RUB.20S-21S Ø060
539018900	INDICE MAN.C/FRECCIA ROSSA
533018500	RACC.BIC.Ø06 M10X1
533039100	BICONO Ø06
531042900	RUB.GAS 21S P.V.BY-P.Ø060
533039300	BICONO Ø10
533010800	DADO ES.X BIC.Ø10 M16X1,5
536034500	MANOP.Ø77 4 P.Ø08X6,5 NERO
539054200	BOLLINO Ø20,3 CR."L" LOTUS R.
539062800	DISC.72.PC-GP R.
533145200	PILOTA STAGNO UG.Ø20
533145300	PILOTA STAGNO UG.Ø35
533091000	UGELLO PILOTA 0100 Ø20 PIL.PC
533091200	UGELLO PILOTA 0100 Ø35 PIL.PC
533043900	INIETTORE CH12X14,0 Ø115
533019300	INIETTORE CH12X14,0 Ø100
533031000	INIETTORE CH12X14,0 Ø175
533043500	INIETTORE CH12X14,0 Ø190
533019400	INIETTORE CH12X14,0 Ø180



COMPONENTI COMUNI CARICO ACQUA PCA S70  
Tav. 560108700M00P00

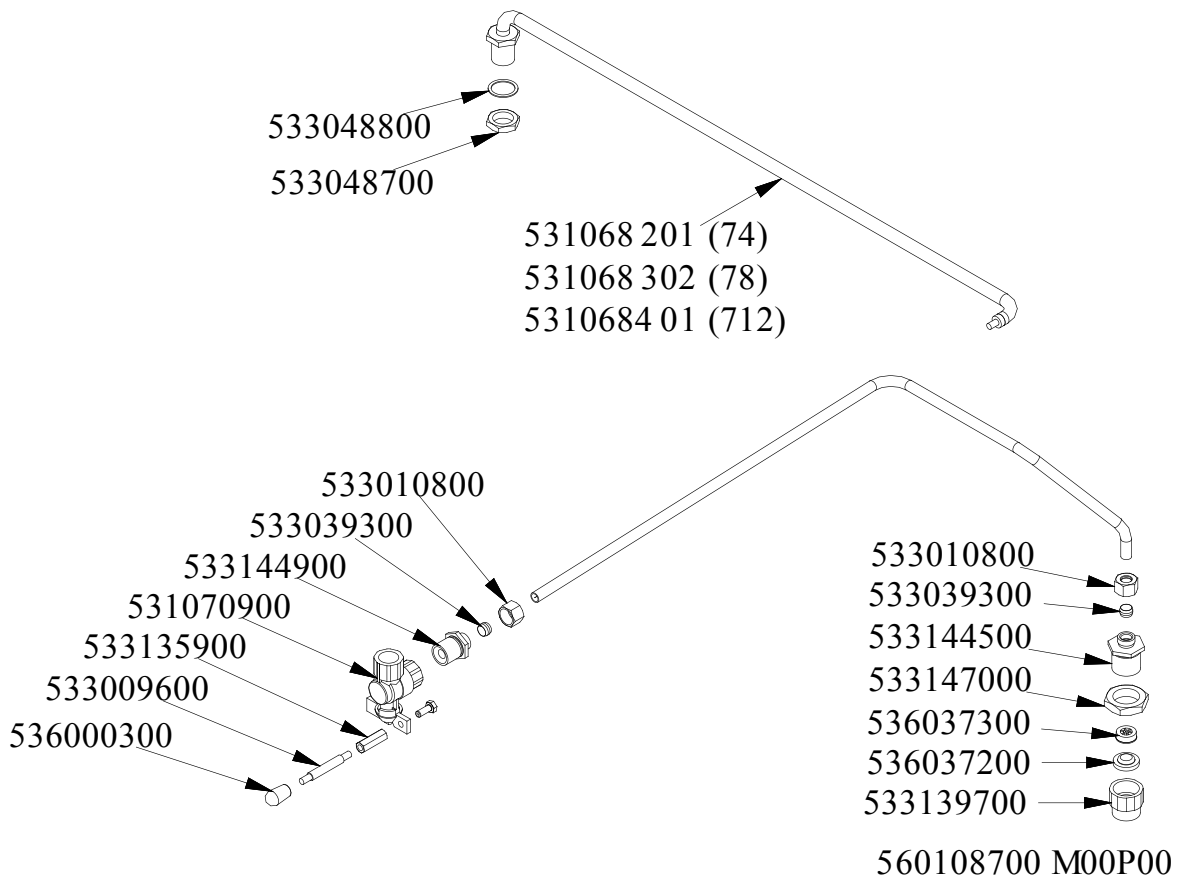



COMPONENTI COMUNI CARICO ACQUA PCA S70 - COMPONENTI COMUNI COMP\_X

Codice	Descrizione
533048800	GUARNIZ.Ø27,5XØ22,0X1,0 FIBRA
533048700	DADO ES.1/2G ZN
531068201	ASS.RACC.CA.H2O 1/2G PCA-74/94
531068302	ASS.RACC.CA.H2O 1/2G PCA-78/98
531068401	ASS.RACC.CA.H2O 1/2G PCA-712/912
533010800	DADO ES.X BIC.Ø10 M16X1,5
533039300	BICONO Ø10
533144900	RACC.INGR.H2O G 1/2 1 M16X1,5 M
531070900	VALV.SFERA 90° 1/2G F/F PCA
533135900	CODICE IN ELABORAZIONE
533009600	MANIGLIA SCAR.RUB.3/4G S60
536000300	IMPUGNAT.Ø15X25XM6
533010800	DADO ES.X BIC.Ø10 M16X1,5
533039300	BICONO Ø10
533144500	RACC.INGR.H2O G 3/4 1 M16X1,5 M
533147000	DADO ES.3/4G OT
536037300	REG.P.ACQUA ENTR.4LT-MIN GIALLO
536037200	GUARNIZ.Ø24,0XØ15,0X4,0 GOMMA+F1
533139700	PROLUNGA 3/4G M/F FE ZINC L 27





FORNO S70 S90 GN2/1 PORTA INOX  
Tav. 560099800M00P00

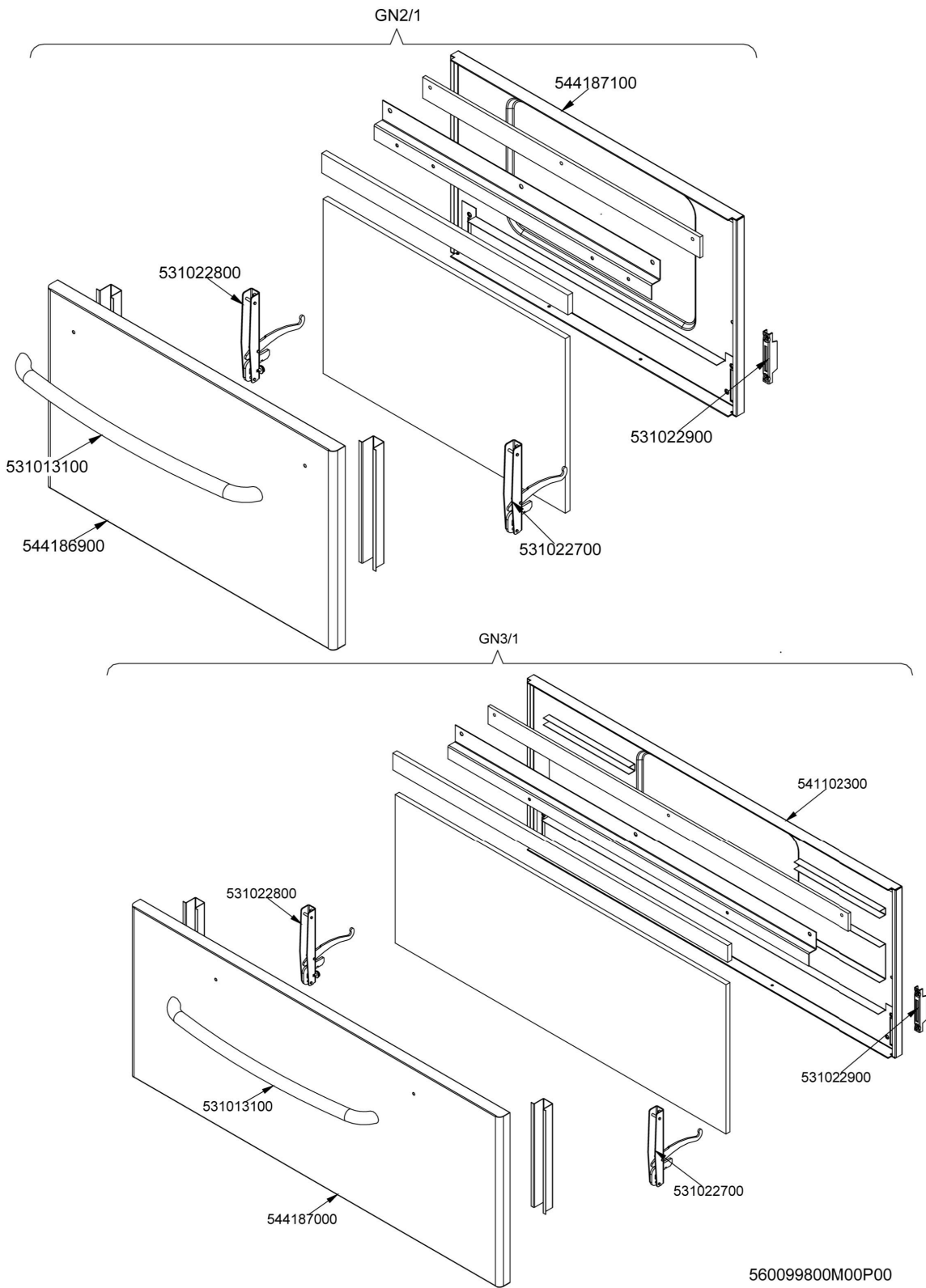



FORNO S70 S90 GN2/1 PORTA INOX - FORNO PORTE\_IPERLOTUS

Codice	Descrizione
_GN2/1	CODICE IN ELABORAZIONE
544187100	CONTROP.FORNO GN2/1 S70/90
531022800	CERNIERA PORTA F.Ø4 S70/90 DX
531013100	MANIGLIA PORTA FORNO S70/90 INOX
544186900	PORTA FORNO GN2/1 S70/90
531022700	CERNIERA PORTA F.Ø4 S70/90 SX
531022900	PORTARULL.CERN.PORTA F.S70/90
GN3/1	CODICE IN ELABORAZIONE
541102300	ASS.CONTROP.FORNO GN3/1 S70
531022800	CERNIERA PORTA F.Ø4 S70/90 DX
531013100	MANIGLIA PORTA FORNO S70/90 INOX
544187000	PORTA FORNO GN3/1 S70/90
531022700	CERNIERA PORTA F.Ø4 S70/90 SX
531022900	PORTARULL.CERN.PORTA F.S70/90



FORNO S70 GN2/1 GAS STATICO CARCASSA CON SCARICO FUMI ALTO  
Tav. 560012300M02P00

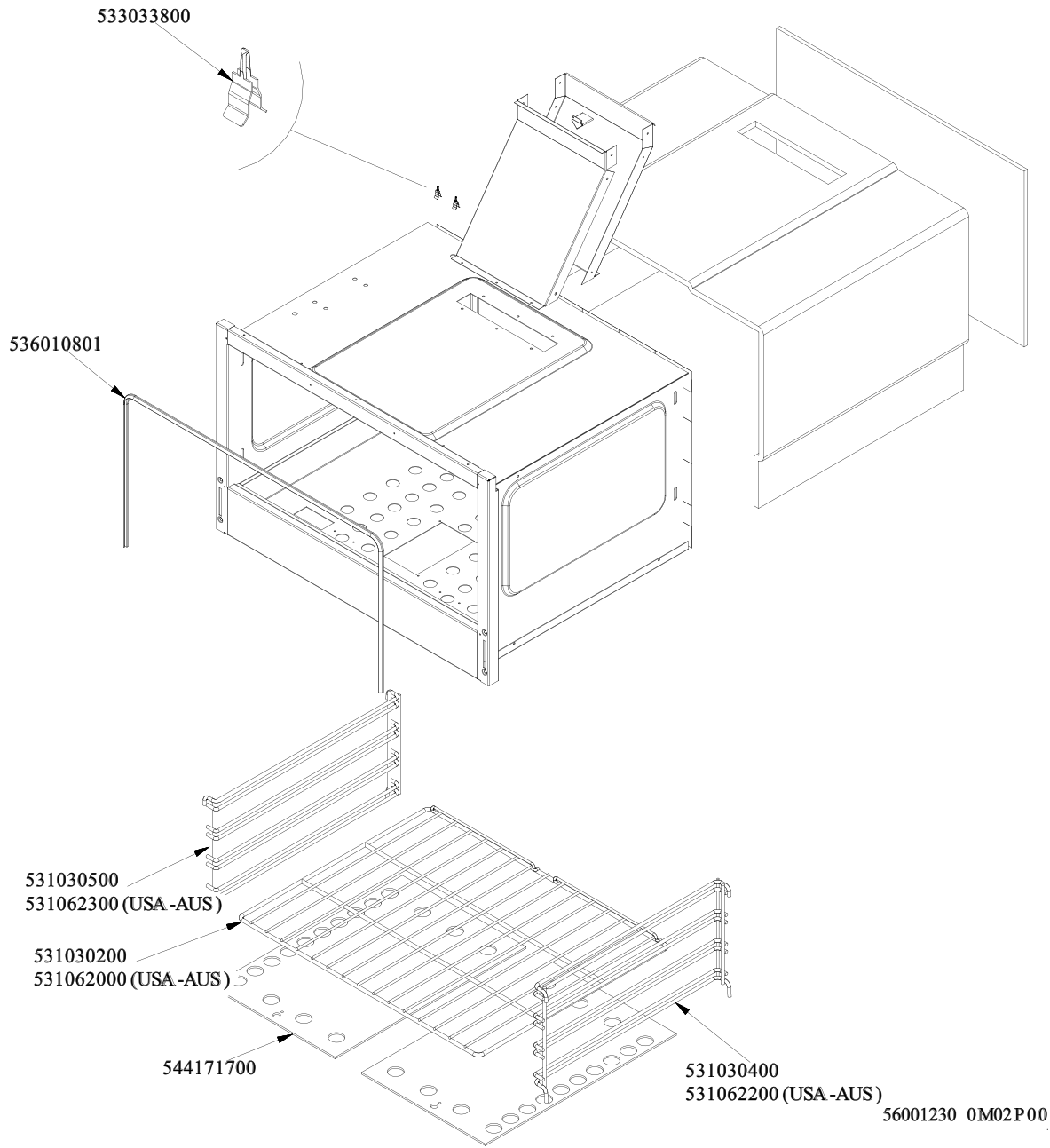



FORNO S70 GN2/1 GAS STATICO CARCASSA CON SCARICO FUMI ALTO - FORNO  
GAS\_GN2/1\_SUPERLOTUS

Codice	Descrizione
533033800	MOLLA FISS.BULB.Ø4/Ø5 PINZA BR.
536010801	GUARNIZ.FORNO GN2/1
531030500	PORTAGRIGLIA FORNO S70 SX
531062300	PORTAGRIGLIA FORNO S70 SX AUS
531030200	GRIGLIA FORNO GN2/1 S70
531062000	GRIGLIA FORNO GN2/1 S70 AUS
544171700	SUOLA FORNO GAS GN2/1 S70
531030400	PORTAGRIGLIA FORNO S70 DX
531062200	PORTAGRIGLIA FORNO S70 DX AUS
-	-



FORNO S70 GN2/1 GAS STATICO CARCASSA CON SCARICO FUMI ALTO  
 Tav. 560034700M03P00

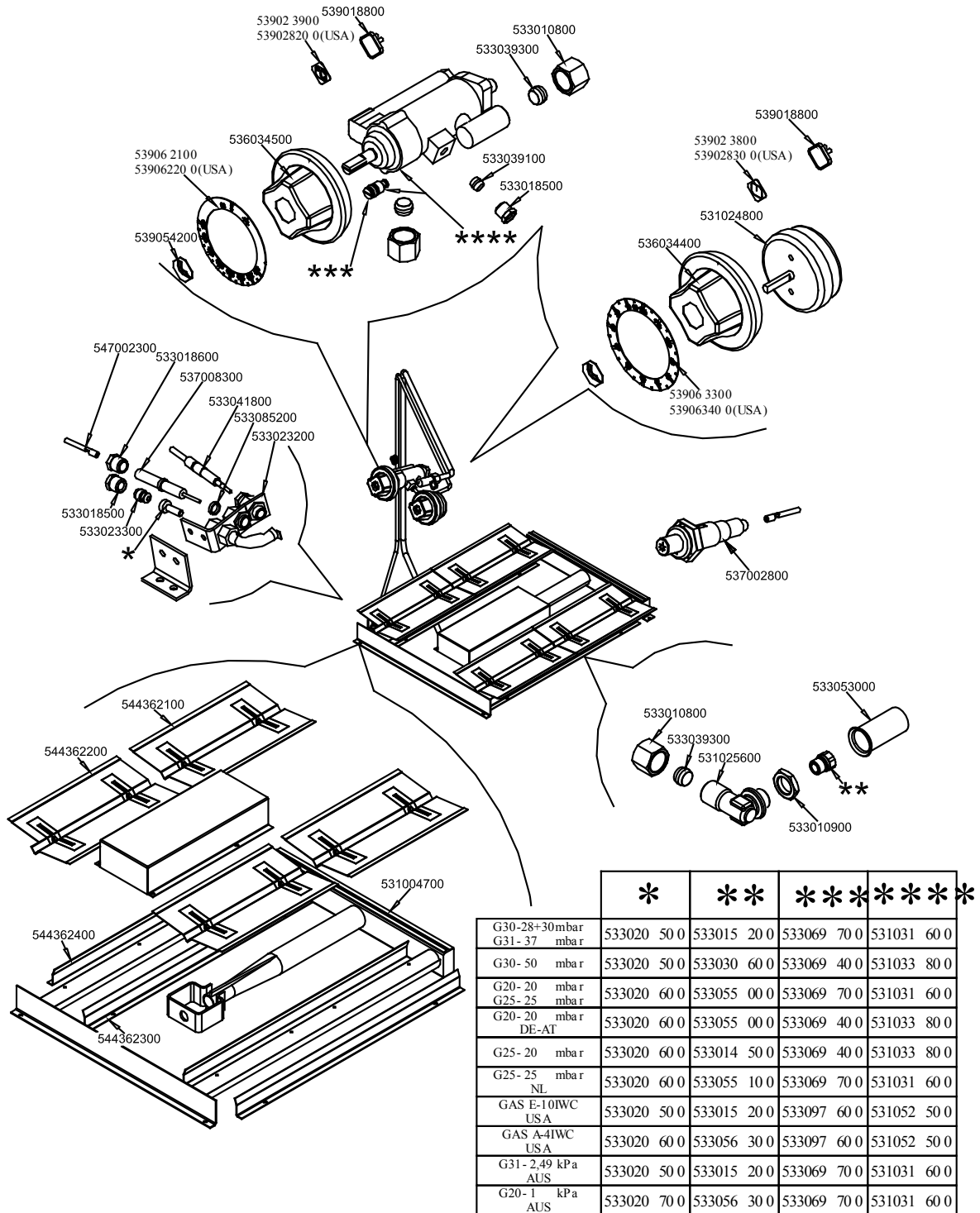



FORNO S70 GN2/1 GAS STATICO CARCASSA CON SCARICO FUMI ALTO - FORNO  
GAS\_GN2/1\_SUPERLOTUS

Codice	Descrizione
539018800	INDICE MAN.C/VANO ETICHETTA
539023900	ET.AD.IND.TEMPERATURA FORNO
539028200	ET.AD.IND.TEMPERATURA FORNO USA
533010800	DADO ES.X BIC.Ø10 M16X1,5
533039300	BICONO Ø10
539018800	INDICE MAN.C/VANO ETICHETTA
539023800	ET.AD.IND.TYMER FORNO
539028300	ET.AD.IND.TYMER FORNO USA
531024800	TIMER MECCANICO 120'
536034400	MANOP.Ø77 4 P.Ø06X4,6 NERO C/M
533039100	BICONO Ø06
533018500	RACC.BIC.Ø06 M10X1
536034500	MANOP.Ø77 4 P.Ø08X6,5 NERO
539062100	DISC.72.FORN.S70 G.ST.RUB.F
539062200	DISC.72.FORN.S70 G.ST.RUB.F USA
539054200	BOLLINO Ø20,3 CR."L" LOTUS R.
547002300	CAV.AT F.F2,8X0,5-TUB.Ø2 L1900(S)
533018600	RACC.CANDELA Ø7 M10X1
537008300	CAND.ACC.PERN.MØ2,4 ELETTR.LUNGO
533041800	TC G.UNI 1500
533085200	DIST.CANDELA PILOTA
533023200	PILOTA 0140 1F RACC.TERMOC.TP
539063300	DISC.72.TYMER MECCANICO
539063400	DISC.72.TYMER MECCANICO USA
533018500	RACC.BIC.Ø06 M10X1
533023300	BICONO PILOTA 0140 Ø06
537002800	PIEZOELETT.M18X1,5 C/D
533053000	BOCCOLA REG.ARIA Ø18 EST.ALT.38
533010800	DADO ES.X BIC.Ø10 M16X1,5
533039300	BICONO Ø10
531025600	RACC.PORTAINIETT.90°CANN.Ø10M16
533010900	DADO ES.M14X1 OT
544362100	DEFL.SUP.BRU.FORNO S70
544362200	DEFL.SUP.PILOTA FORNO S70
531004700	BRU.FORNO GN2/1 S70
544362400	DEFL.LAT.PILOTA FORNO S70
544362300	DEFL.LAT.BRU.FORNO S70
533020500	UGELLO PILOTA 0140 Ø19 LUNGO
533020600	UGELLO PILOTA 0140 Ø27 LUNGO
533020700	UGELLO PILOTA 0140 Ø35 LUNGO
533015200	INIETTORE CH12X14,0 Ø145
533030600	INIETTORE CH12X14,0 Ø125
533055000	INIETTORE CH12X14,0 Ø205
533014500	INIETTORE CH12X14,0 Ø225
533055100	INIETTORE CH12X14,0 Ø215
533056300	INIETTORE CH12X14,0 Ø240
533069700	BY-P.RUB.25ST Ø075
533069400	BY-P.RUB.25ST Ø065
533097600	BY-P.RUB.25ST Ø090
531031600	RUB.GAS 25ST P.O.BY-P.Ø075 TER
531033800	RUB.GAS 25ST P.O.BY-P.Ø065 TER
531052500	RUB.GAS 25ST P.O.BY-P.Ø090 TER