

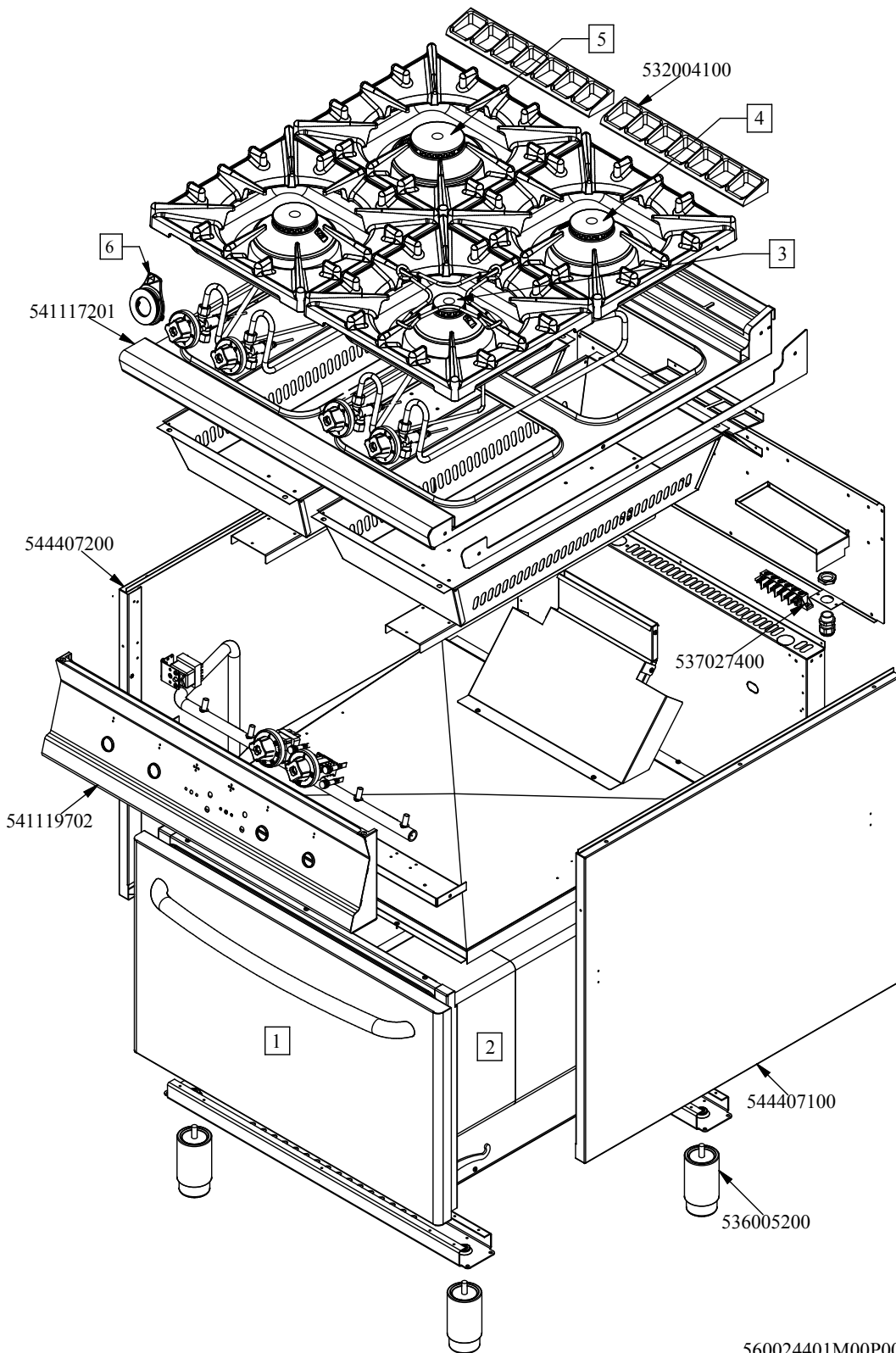

CF4-98GE (SN>=1605)  
Tav. 560024401M00P00



560024401M00P00





FORNO S70 S90 GN2/1 PORTA INOX  
Tav. 560099800M00P00

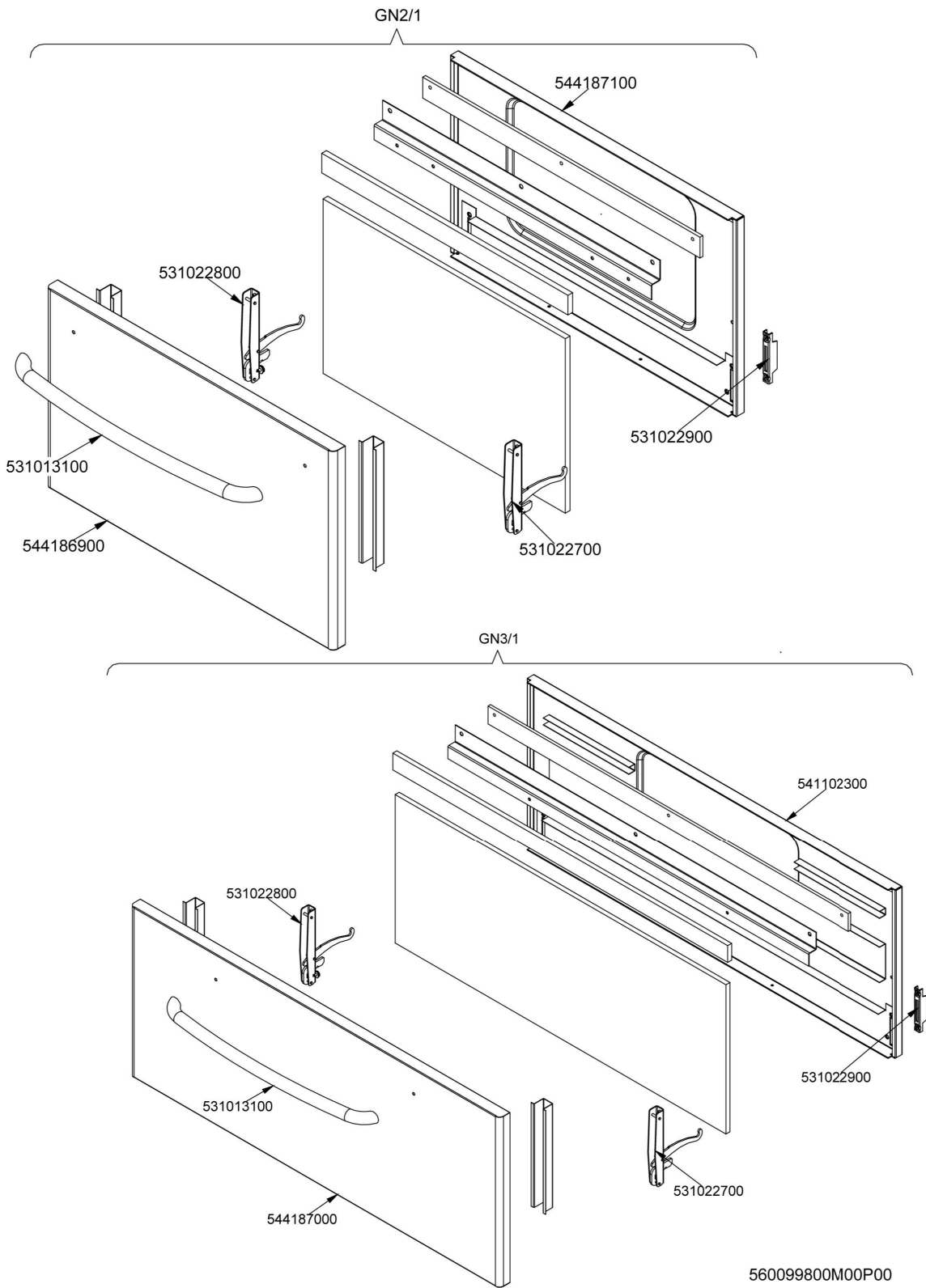



FORNO S70 S90 GN2/1 PORTA INOX - FORNO PORTE\_IPERLOTUS

Codice	Descrizione
_GN2/1	CODICE IN ELABORAZIONE
544187100	CONTROP.FORNO GN2/1 S70/90
531022800	CERNIERA PORTA F.Ø4 S70/90 DX
531013100	MANIGLIA PORTA FORNO S70/90 INOX
544186900	PORTA FORNO GN2/1 S70/90
531022700	CERNIERA PORTA F.Ø4 S70/90 SX
531022900	PORTARULL.CERN.PORTA F.S70/90
GN3/1	CODICE IN ELABORAZIONE
541102300	ASS.CONTROP.FORNO GN3/1 S70
531022800	CERNIERA PORTA F.Ø4 S70/90 DX
531013100	MANIGLIA PORTA FORNO S70/90 INOX
544187000	PORTA FORNO GN3/1 S70/90
531022700	CERNIERA PORTA F.Ø4 S70/90 SX
531022900	PORTARULL.CERN.PORTA F.S70/90





COMPONENTI COMUNI FORNO S90 GN2/1 ELETTRICO STATICO CARCASSA  
Tav. 560020001M00P00

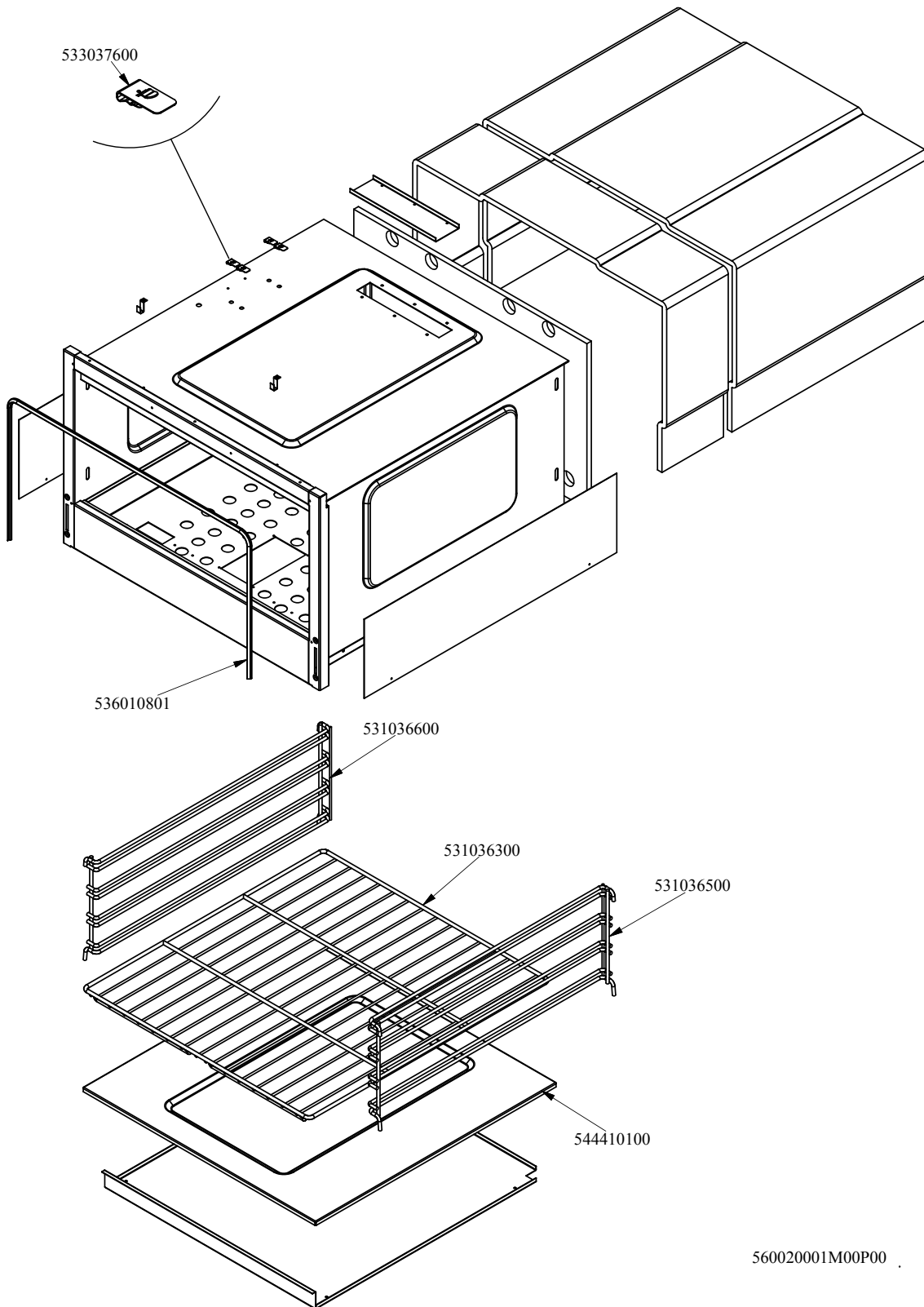



COMPONENTI COMUNI FORNO S90 GN2/1 ELETTRICO STATICO CARCASSA -  
COMPONENTI COMUNI FORNO S90 GN2/1 ELETTRICO STATICO CARCASSA (SNMATRDA

Codice	Descrizione
531036500	PORTAGRIGLIA FORNO S90 DX
531036600	PORTAGRIGLIA FORNO S90 SX
531036300	GRIGLIA FORNO GN2/1 S90
544410100	SUOLA FORNO EL.GN2/1 S90
536010801	GUARNIZ.FORNO GN2/1
533037600	MOLLA FISS.BULB.Ø3/Ø4 PIATTA BR.
-	CODICE IN ELABORAZIONE



COMPONENTI COMUNI FORNO S90 GN2/1 ELETTRICO STATICO IMPIANTO  
Tav. 560020102M00P00

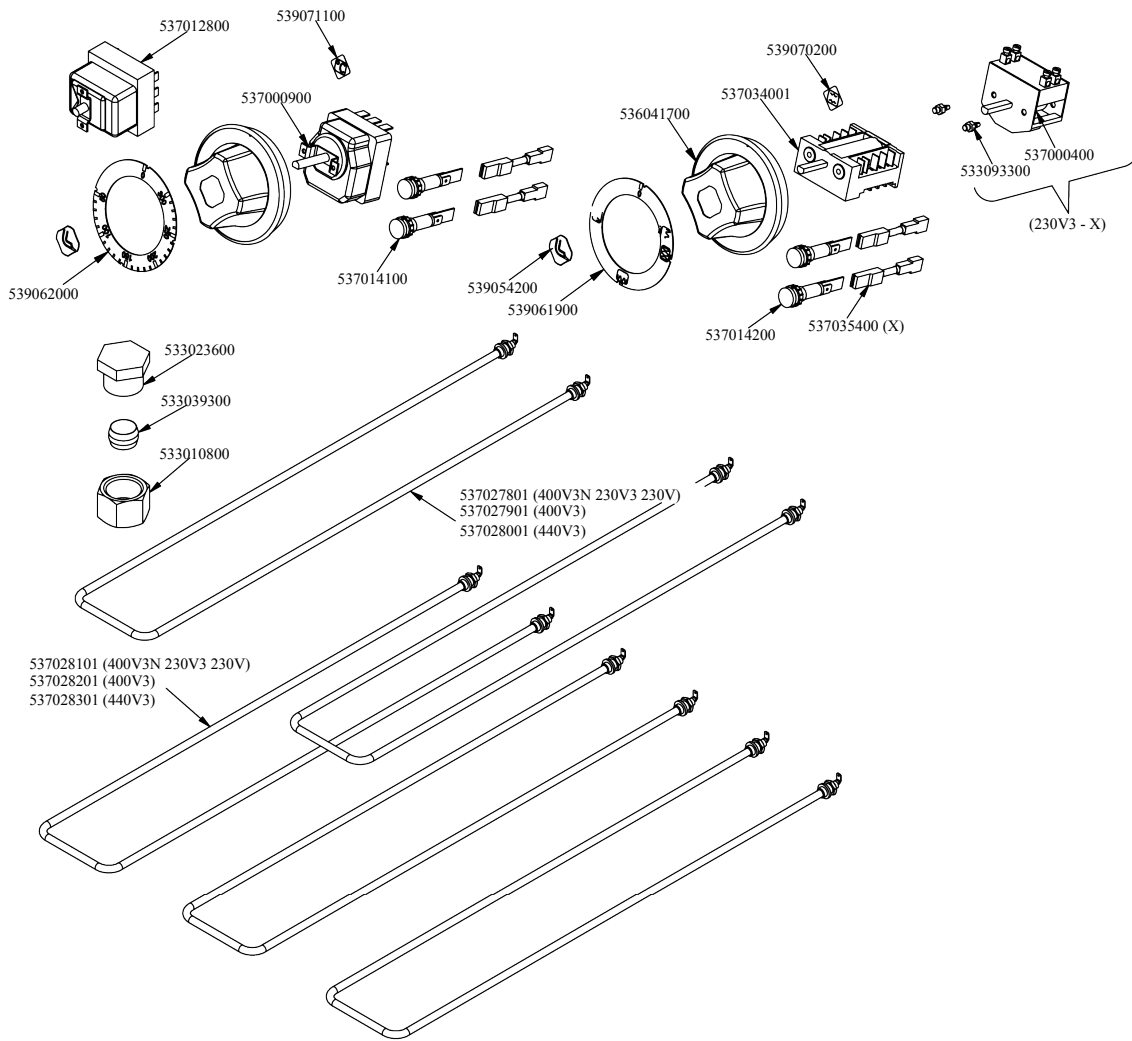



COMPONENTI COMUNI FORNO S90 GN2/1 ELETTRICO STATICO IMPIANTO -  
COMPONENTI COMUNI FORNO S90 GN2/1 ELETTRICO STATICO IMPIANTO (SNMATRDA1

Codice	Descrizione
537027801	RES.COR.FOR.S90 S.0800W 1-230V (T)
537012800	TERMOST.SIC.TRIF. 420°C
537000900	TERMOST.F.TRIF. 063-320°C GAMB.L
539071100	ET.AD.GHIER.FORNO TEMP.°C
537014100	SPIA G.B.BIANC.250VAC F.M.
533023600	TAPPO ATT.RUB.Ø10 M16X1,5 CH19
533039300	BICONO Ø10
533010800	DADO ES.X BIC.Ø10 M16X1,5
537027901	CODICE IN ELABORAZIONE
537028001	CODICE IN ELABORAZIONE
537028101	RES.COR.FOR.S90 L1700W 1-230V (T)
537028201	CODICE IN ELABORAZIONE
537028301	CODICE IN ELABORAZIONE
536041700	MANOP.Ø77 4P.G.Ø06 X4,6 CROMO
539062000	DISC.72.FORN.S70 E.ST.TERM.
539061900	DISC.72.FORN.S70 E.ST.COMM.
539054200	BOLLINO Ø20,3 CR."L" LOTUS R.
537035400	RES.ELETTR.3W 330KOHM C/F
533093300	PERNO FISS.COMMUT.S.43 TERMOST.
537000400	COMM.1 POS.1F 16A
537014200	SPIA G.B.VERDE 250VAC F.M.
537034001	COMM.4 POS.3F 16A FORNO
539070200	CODICE IN ELABORAZIONE



COMPONENTI COMUNI COMANDO E BRUCIATORE PC-G S90 1UR  
Tav. 560023301M00P00

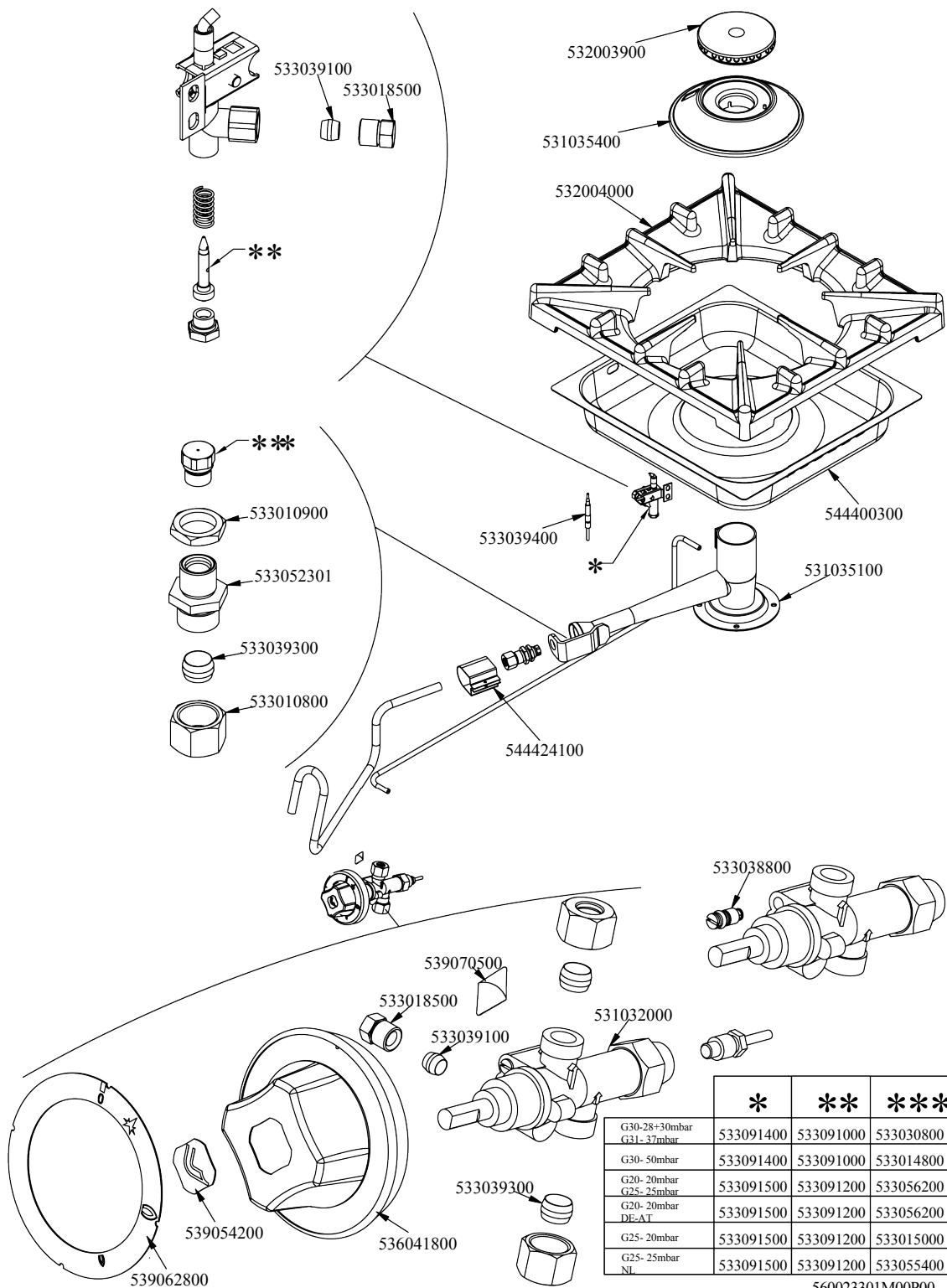

560023301M00P00



## COMPONENTI COMUNI COMANDO E BRUCIATORE PC-G S90 1UR - COMP\_02\_06

Codice	Descrizione
533030800	INIETTORE CH12X14,0 Ø155
533014800	INIETTORE CH12X14,0 Ø135
533056200	INIETTORE CH12X14,0 Ø230
533015000	INIETTORE CH12X14,0 Ø260
533055400	INIETTORE CH12X14,0 Ø245
533091000	UGELLO PILOTA 0100 Ø20 PIL.PC
533091200	UGELLO PILOTA 0100 Ø35 PIL.PC
533091400	PILOTA 0100 1F RACC.BIC.UG.Ø20
533091500	PILOTA 0100 1F RACC.BIC.UG.Ø35
539054200	BOLLINO Ø20,3 CR."L" LOTUS R.
539062800	DISC.72.PC-GP R.
536041800	MANOP.Ø77 4P.G.Ø08 X6,5 CROMO
533039300	BICONO Ø10
533039100	BICONO Ø06
531035400	CORPO BRU.F1 10 KW S90
532004000	GRIGLIA PC S90 396X366 1F.RAF
544424100	BOCCOLA REG.ARIA BRU.PC S90
533039400	TC G.UNI 0850
533018500	RACC.BIC.Ø06 M10X1
539070500	ET.AD.GHIER.INDICE ROSSO
533010800	DADO ES.X BIC.Ø10 M16X1,5
533052301	RACC.PORTAINIETT. 0°CANN.Ø10
533010900	DADO ES.M14X1 OT
532003900	SPARTIF.CORONA Ø100 S90
544400300	BAC.BRU.S90 PC GN2/3 10KW
531035100	VENTURI BRU.F1 10 KW S90
531032000	RUB.GAS 21S P.V.BY-P.Ø075
533038800	BY-P.RUB.20S-21S Ø075



COMPONENTI COMUNI COMANDO E BRUCIATORE PC-G S90 2R  
Tav. 560023201M00P00

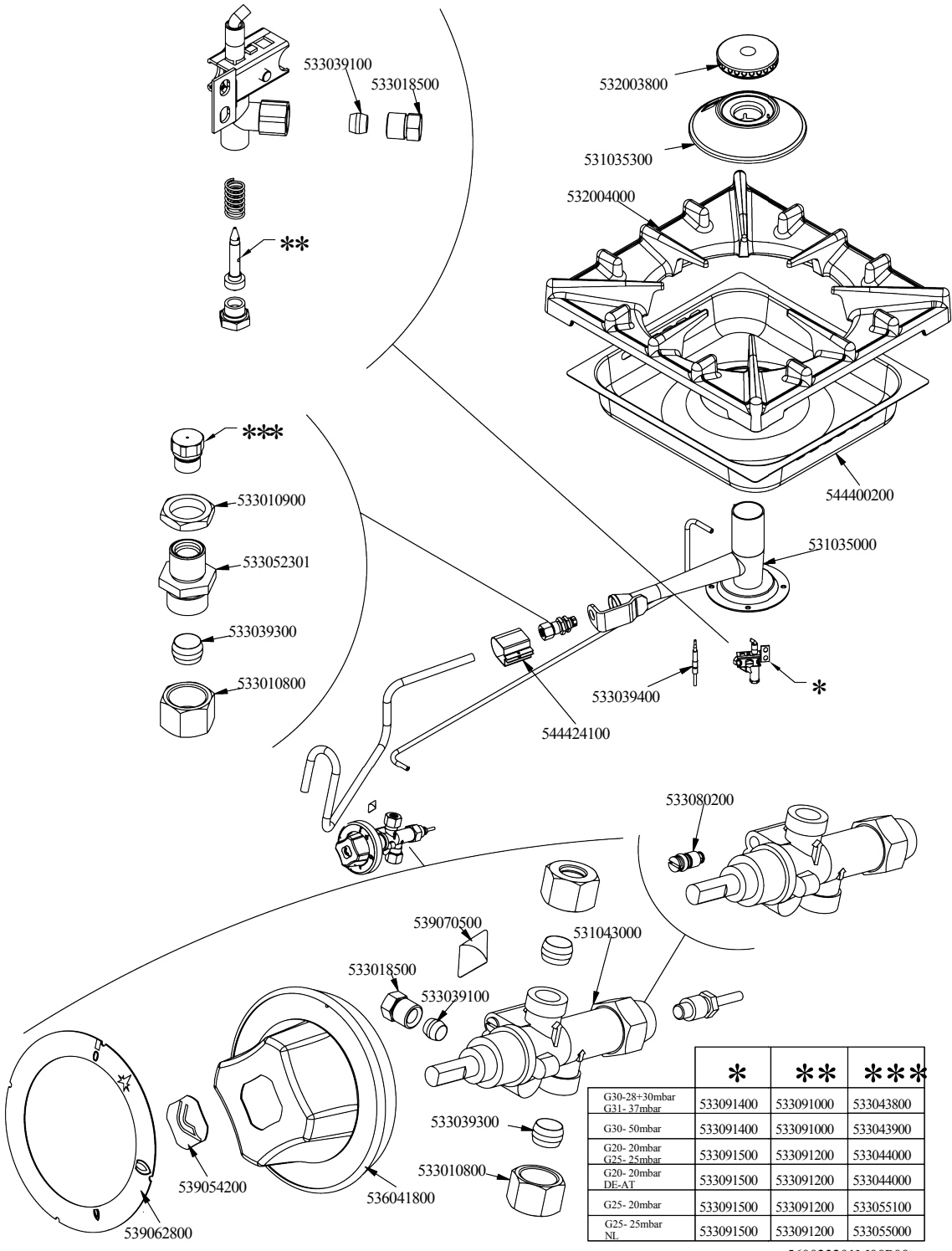

	*	**	***
G30-28+30mbar G31-37mbar	533091400	533091000	533043800
G30-50mbar	533091400	533091000	533043900
G20-20mbar G25-25mbar	533091500	533091200	533044000
G20-20mbar DE-AT	533091500	533091200	533044000
G25-20mbar	533091500	533091200	533055100
G25-25mbar NL	533091500	533091200	533055000

560023201M00P00



## COMPONENTI COMUNI COMANDO E BRUCIATORE PC-G S90 2R - COMP\_02\_02

Codice	Descrizione
533043800	INIETTORE CH12X14,0 Ø130
533043900	INIETTORE CH12X14,0 Ø115
533044000	INIETTORE CH12X14,0 Ø195
533055100	INIETTORE CH12X14,0 Ø215
533055000	INIETTORE CH12X14,0 Ø205
533091000	UGELLO PILOTA 0100 Ø20 PIL.PC
533091200	UGELLO PILOTA 0100 Ø35 PIL.PC
533091400	PILOTA 0100 1F RACC.BIC.UG.Ø20
533091500	PILOTA 0100 1F RACC.BIC.UG.Ø35
539054200	BOLLINO Ø20,3 CR."L" LOTUS R.
539062800	DISC.72.PC-GP R.
536041800	MANOP.Ø77 4P.G.Ø08 X6,5 CROMO
533039100	BICONO Ø06
533010900	DADO ES.M14X1 OT
533052301	RACC.PORTAINIETT. 0°CANN.Ø10
533039300	BICONO Ø10
533010800	DADO ES.X BIC.Ø10 M16X1,5
533018500	RACC.BIC.Ø06 M10X1
532003800	SPARTIF.CORONA Ø082 S90
531035300	CORPO BRU.F1 7 KW S90
532004000	GRIGLIA PC S90 396X366 1F.RAF
544400200	BAC.BRU.S90 PC GN2/3 07KW
531035000	VENTURI BRU.F1 7 KW S90
544424100	BOCCOLA REG.ARIA BRU.PC S90
533039400	TC G.UNI 0850
531043000	RUB.GAS 21S P.V.BY-P.Ø065
539070500	ET.AD.GHIER.INDICE ROSSO
533080200	BY-P.RUB.20S-21S Ø065





COMPONENTI COMUNI COMANDO E BRUCIATORE PC-G S90 3SR  
Tav. 560023101M00P00

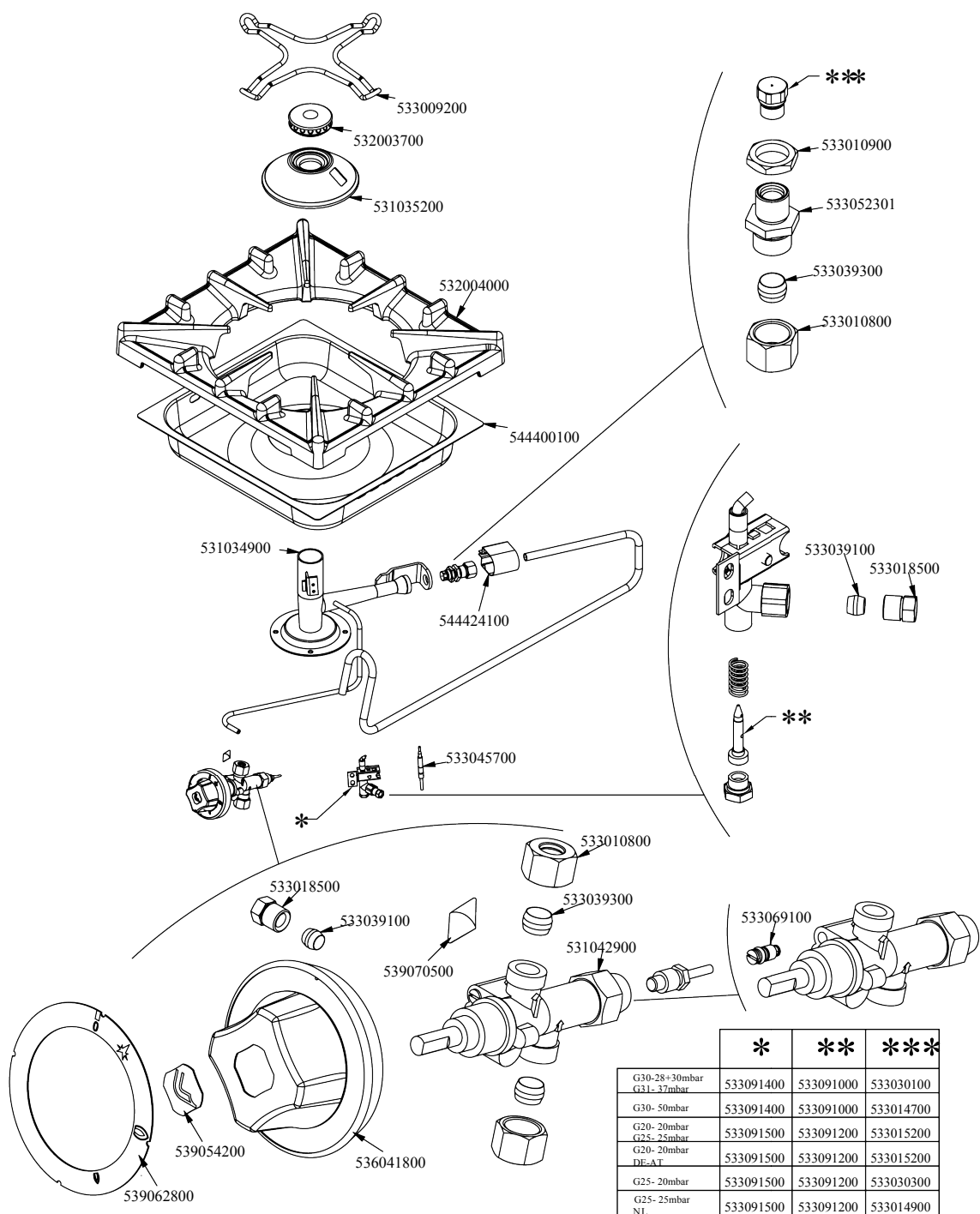

	*	**	***
G30-28+30mbar G31- 27mbar	533091400	533091000	533030100
G30- 50mbar	533091400	533091000	533014700
G20- 20mbar G25- 25mbar	533091500	533091200	533015200
G20- 20mbar DE-AT	533091500	533091200	533015200
G25- 20mbar	533091500	533091200	533030300
G25- 25mbar NL	533091500	533091200	533014900

560023101M00P00 .



## COMPONENTI COMUNI COMANDO E BRUCIATORE PC-G S90 3SR - COMP\_02\_04

Codice	Descrizione
533030100	INIETTORE CH12X14,0 Ø095
533014700	INIETTORE CH12X14,0 Ø085
533015200	INIETTORE CH12X14,0 Ø145
533030300	INIETTORE CH12X14,0 Ø160
533014900	INIETTORE CH12X14,0 Ø150
533091000	UGELLO PILOTA 0100 Ø20 PIL.PC
533091200	UGELLO PILOTA 0100 Ø35 PIL.PC
533091400	PILOTA 0100 1F RACC.BIC.UG.Ø20
533091500	PILOTA 0100 1F RACC.BIC.UG.Ø35
539054200	BOLLINO Ø20,3 CR."L" LOTUS R.
539062800	DISC.72.PC-GP R.
536041800	MANOP.Ø77 4P.G.Ø08 X6,5 CROMO
533039300	BICONO Ø10
533010800	DADO ES.X BIC.Ø10 M16X1,5
531042900	RUB.GAS 21S P.V.BY-P.Ø060
533009200	GRIGLIA RID.FUOCHI S65 S70/90 FO
532003700	SPARTIF.CORONA Ø060 S90
531035200	CORPO BRU.F1 4 KW S90
532004000	GRIGLIA PC S90 396X366 1F.RAF
544400100	BAC.BRU.S90 PC GN2/3 04KW
531034900	VENTURI BRU.F1 4 KW S90
533018500	RACC.BIC.Ø06 M10X1
533039100	BICONO Ø06
539070500	ET.AD.GHIER.INDICE ROSSO
544424100	BOCCOLA REG.ARIA BRU.PC S90
533045700	TC G.UNI 0500
533069100	BY-P.RUB.20S-21S Ø060
533052301	RACC.PORTAINIETT. 0°CANN.Ø10
533010900	DADO ES.M14X1 OT



COMPONENTI COMUNI GHIERA CON CUFFIA  
Tav. 560125700M00P00

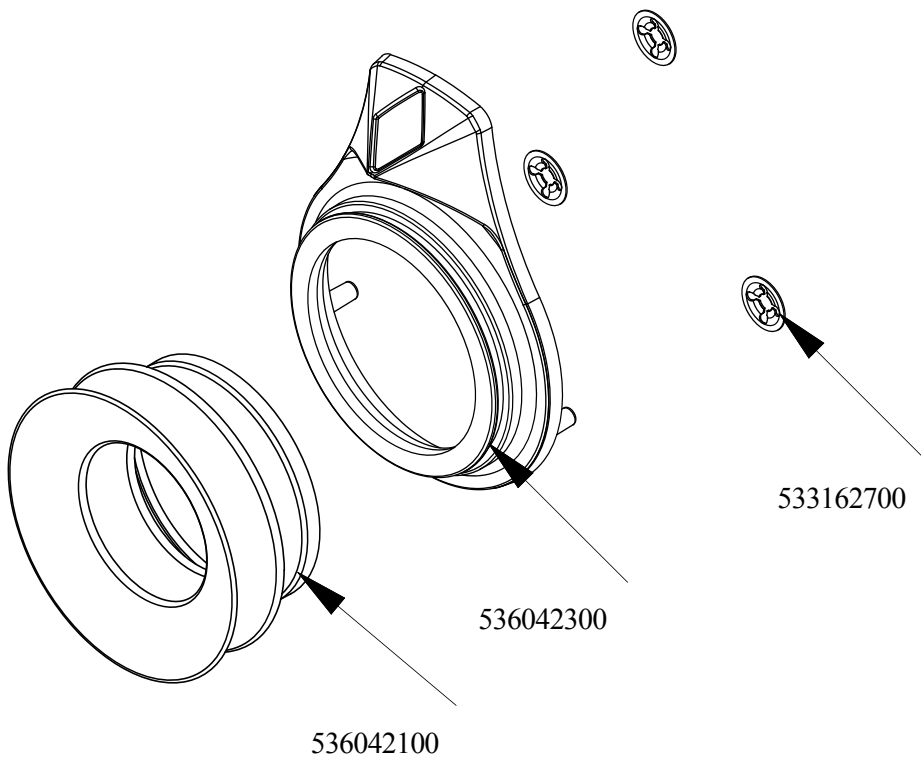

560125700M00P00



COMPONENTI COMUNI GHIERA CON CUFFIA -  
COMPONENTI COMUNI GHIERA CON CUFFIA (SNMATRDA1605)

Codice	Descrizione
536042300	GHIERA MAN.Ø77 4 PUNTE CROMO
536042100	CUFFIA X GHIERA X MAN.Ø77 4 PUNT
533162700	CODICE IN ELABORAZIONE