

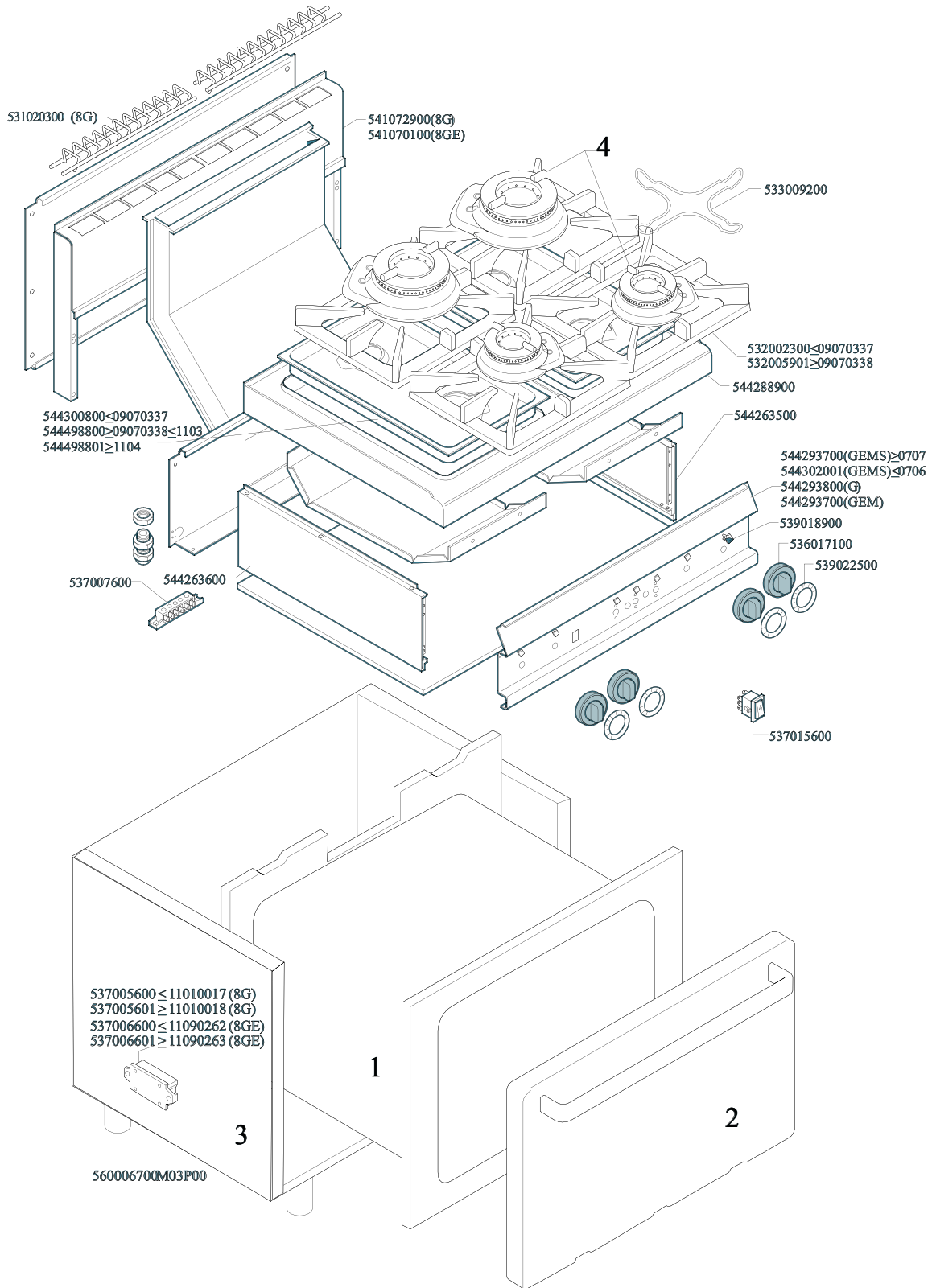

CF4-8GEM (SN<=0308)  
Tav. 560006700M03P00





CF4-8GEM (SN<=0308) - CUCINE MATR FINO 0308 CF4-8GEM MATR FINO 0308

Codice	Descrizione
541070100	ASS.DIST.S65 8 NEUTRO
533009200	GRIGLIA RID.FUOCHI S65 S70/90 FO
532002300	GRIGLIA PC S65 344X272 1F.SM.N.(S)
532005901	GRIGLIA PC S65 340X270 1F.RAF
544288900	PIANO S65 PC- 8G CF4-8G/GEM
544263500	FIANCO APP.S65T DX
544300800	BAC.BRU.S65 PC GN1/1 SM.N.LUC. (S)
544498800	BAC.BRU.S65 PC GN1/1 SM.N.RAF (S)
544498801	BAC.BRU.S65 PC GN1/1 AISI 304
544293700	CRUSC.S65 CF 4-8GEM
539018900	INDICE MAN.C/FRECCIA ROSSA
536017100	MANOP.Ø70 PEL Ø08X6,5 SEDE PERP.
539022500	DISC.64.PC-G R.
537007600	MORSETT.3 POLI 40A VITE-FASTON (S)
544263600	FIANCO APP.S65T SX
537015600	P.C.INTERR.IST.NERO FULMINE (S)
537006600	CENTR.ACC.4F.230V (S)
537006601	CENTR.ACC.4F.230V
-	-
-	-
-	-
-	-



COMANDO E BRUCIATORE PC-G S65 R UR  
Tav. 560038100M00P00

	*	**
G30- 28+30mbar G31- 37mbar	533015400	533043400
G30- 50mbar	533015300	533043300
G20- 20mbar G25- 25mbar	533015200	533019400
G25- 20mbar	533030300	533043600
G25- 25mbar NL	533014900	533043500

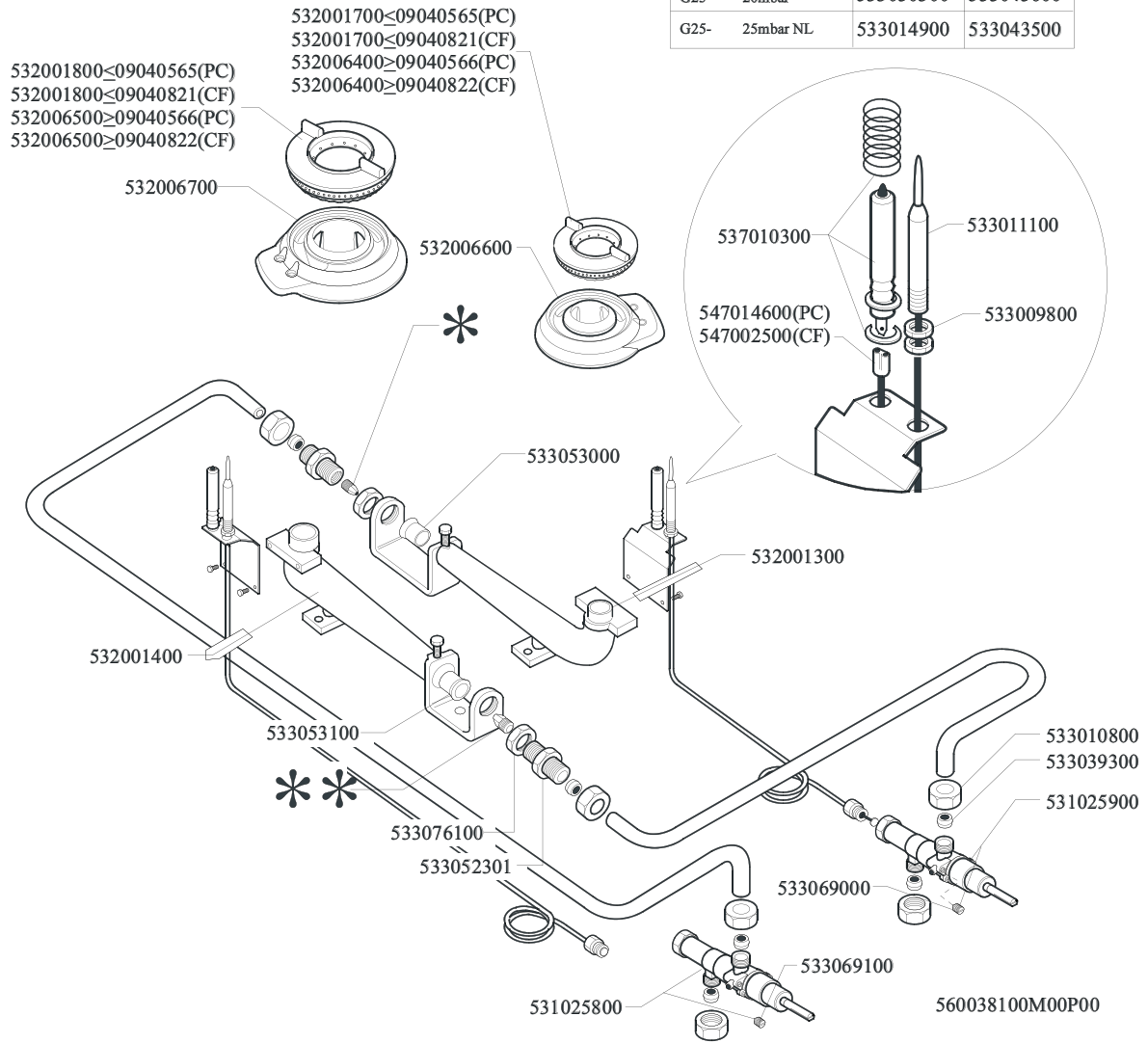



COMANDO E BRUCIATORE PC-G S65 R UR - COMPONENTI COMUNI COMANDO\_PC-G

Codice	Descrizione
532001700	SPARTIF.D.CORONA Ø082 S65 (S)
532006400	SPARTIF.D.CORONA Ø082 3 Z S60T
532001800	SPARTIF.D.CORONA Ø102 S65 (S)
532006500	SPARTIF.D.CORONA Ø102 3 Z S60T
532006700	CORPO BRU.L1 5,5KW C/S S60 NICH
532006600	CORPO BRU.L1 3,5KW C/S S60 NICH
533011100	TC G.M08X1 0750
537010300	CAND.ACC.FAST.M2,8X0,8 MOLLA 2 S
547014600	CAV.AT F.F2,8X0,8-TUB.Ø2 L0800
533053000	BOCCOLA REG.ARIA Ø18 EST.ALT.38
532001300	VENTURI BRU.L1 3,5KW S65
532001400	VENTURI BRU.L1 5,5KW S65
533053100	BOCCOLA REG.ARIA Ø20 EST.ALT.38
533076100	BOCCOLA CENTR.Ø20 (S)
533052301	RACC.PORTAINIETT. 0°CANN.Ø10
533010800	DADO ES.X BIC.Ø10 M16X1,5
533039300	BICONO Ø10
531025900	RUB.GAS 20S P.V.BY-P.Ø070
533069000	BY-P.RUB.20S-21S Ø070
533069100	BY-P.RUB.20S-21S Ø060
531025800	RUB.GAS 20S P.V.BY-P.Ø060
533015400	INIETTORE CH12X14,0 Ø093
533015300	INIETTORE CH12X14,0 Ø082
533015200	INIETTORE CH12X14,0 Ø145
533030300	INIETTORE CH12X14,0 Ø160
533014900	INIETTORE CH12X14,0 Ø150
533043400	INIETTORE CH12X14,0 Ø117
533043300	INIETTORE CH12X14,0 Ø103
533019400	INIETTORE CH12X14,0 Ø180
533043600	INIETTORE CH12X14,0 Ø200
533043500	INIETTORE CH12X14,0 Ø190



FORNO MAXI ELETTRICO MULTIFUNZIONE S65  
Tav. 560003800M01P00

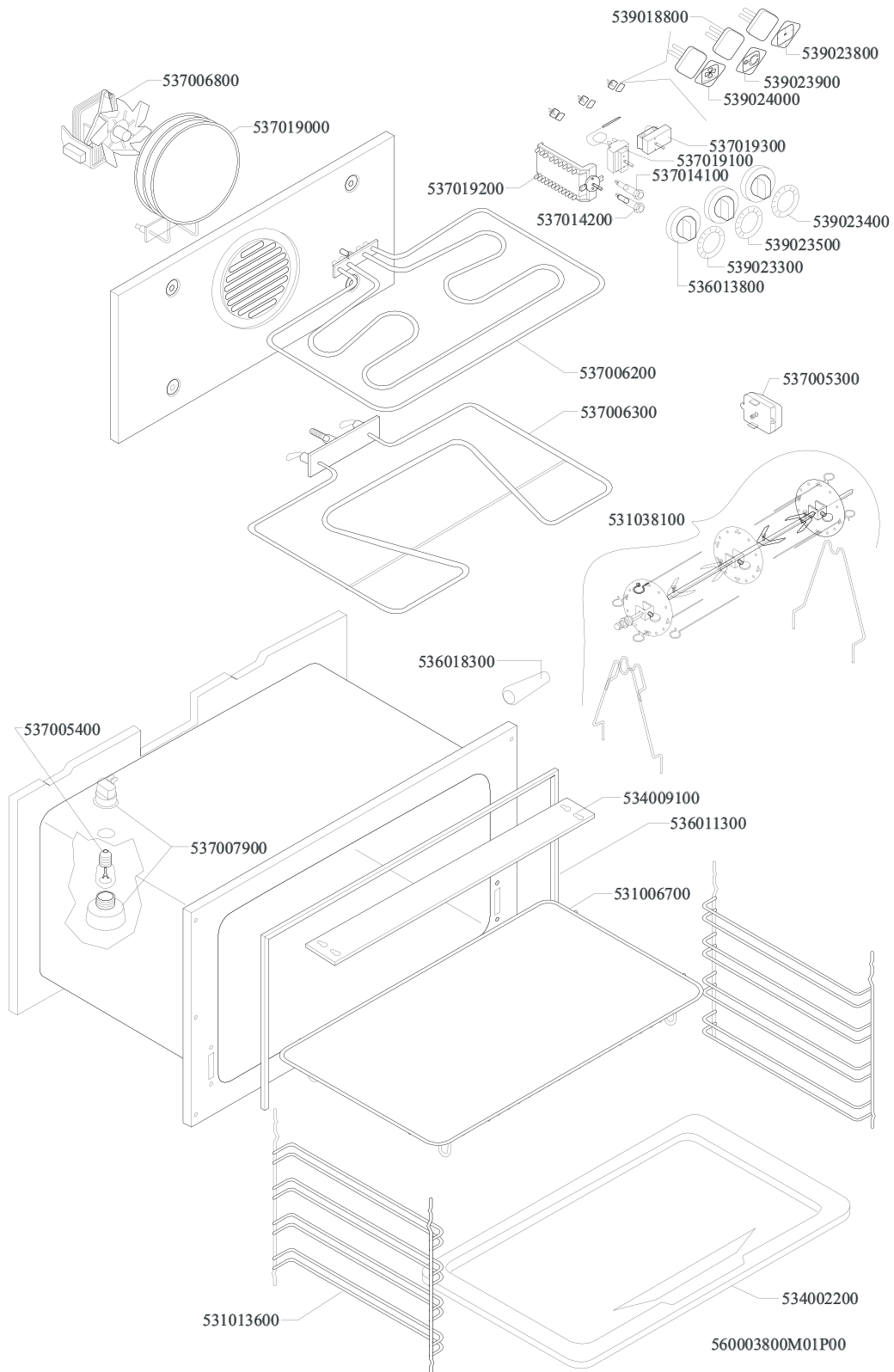



FORNO MAXI ELETTRICO MULTIFUNZIONE S65 - FORNO MATR FINO 0308 MULTIFUNZIONE ELETTRICO

Codice	Descrizione
539018800	INDICE MAN.C/VANO ETICHETTA
539023800	ET.AD.IND.TYMER FORNO
539023900	ET.AD.IND.TEMPERATURA FORNO
539024000	ET.AD.IND.COMM.FORNO ELETTR.MF.
537006800	MOTOVENT.FORNO MULT. S60/65/60T (S)
537019000	RES.COR.FOR.S60 C.3000W 1-230V (T)
537019300	TIMER ELETT. 120' 6 T.F.MF (RIC) (S)
537019100	TERMOST.F.MONOF.050-320°C F.MMF (S)
537014100	SPIA G.B.BIANC.250VAC F.M.
537019200	COMM.FORNO MAXI MULTIF. (S)
537014200	SPIA G.B.VERDE 250VAC F.M.
539023400	DISC.64.FORN. E.MF.TYMER
539023500	DISC.64.FORN.S60 E.MF.TERM. (S)
539023300	DISC.64.FORN.S60 E.MF.COMM. (S)
536013800	MANOP.Ø70 PEL Ø06X5 SEDE PERP.
537006200	RES.COR.FOR.MAX S.3000W 1-230V
537005300	MOTORINO GIRARR.CFM-8/10E (S)
537006300	RES.COR.FOR.MAX I.1600W 1-230V (S)
531038100	SPIEDO GIRARR.F.MAXI MULTIF.TN (S)
536018300	IMPUGNAT.SPIEDO GIRARR. (S)
537005400	LAMP.FORNO 15W 230/240V 300°C (S)
534009100	PROTEZ.MANOPOLE FORNO MAXI S60
536011300	GUARNIZ.FORNO MAXI S60 S65 (S)
537007900	PORTALAMPADA FORNO C/L.S60T/65
531006700	GRIGLIA FORNO MAXI S60/65 (S)
534002200	LECCARDA FORNO MAXI S60/65 (S)
531013600	PORTAGRIGLIA FORNO MINI (S-I) (S)



CARCASSA CF S65  
Tav. 560013400M01P00

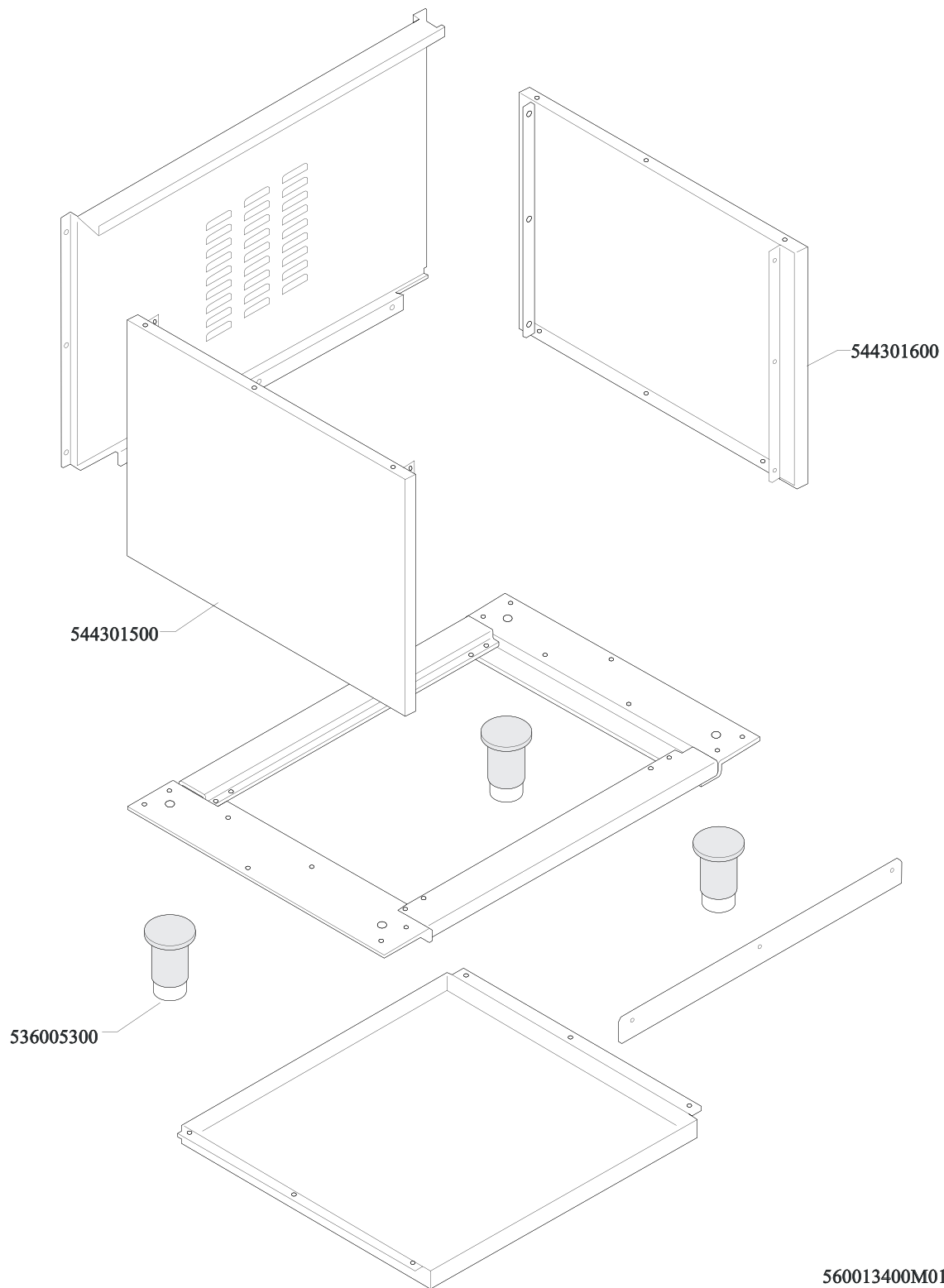



CARCASSA CF S65 - COMPONENTI COMUNI CARCASSA\_CF

Codice	Descrizione	P
544301600	FIANCO APP.S65M CF DX	
544301500	FIANCO APP.S65M CF SX	
536005300	PIEDE Ø2" 120-170 M10 PLAST (S)	





FORNO MAXI PORTA INOX E VETRO S65  
Tav. 560007000M01P00

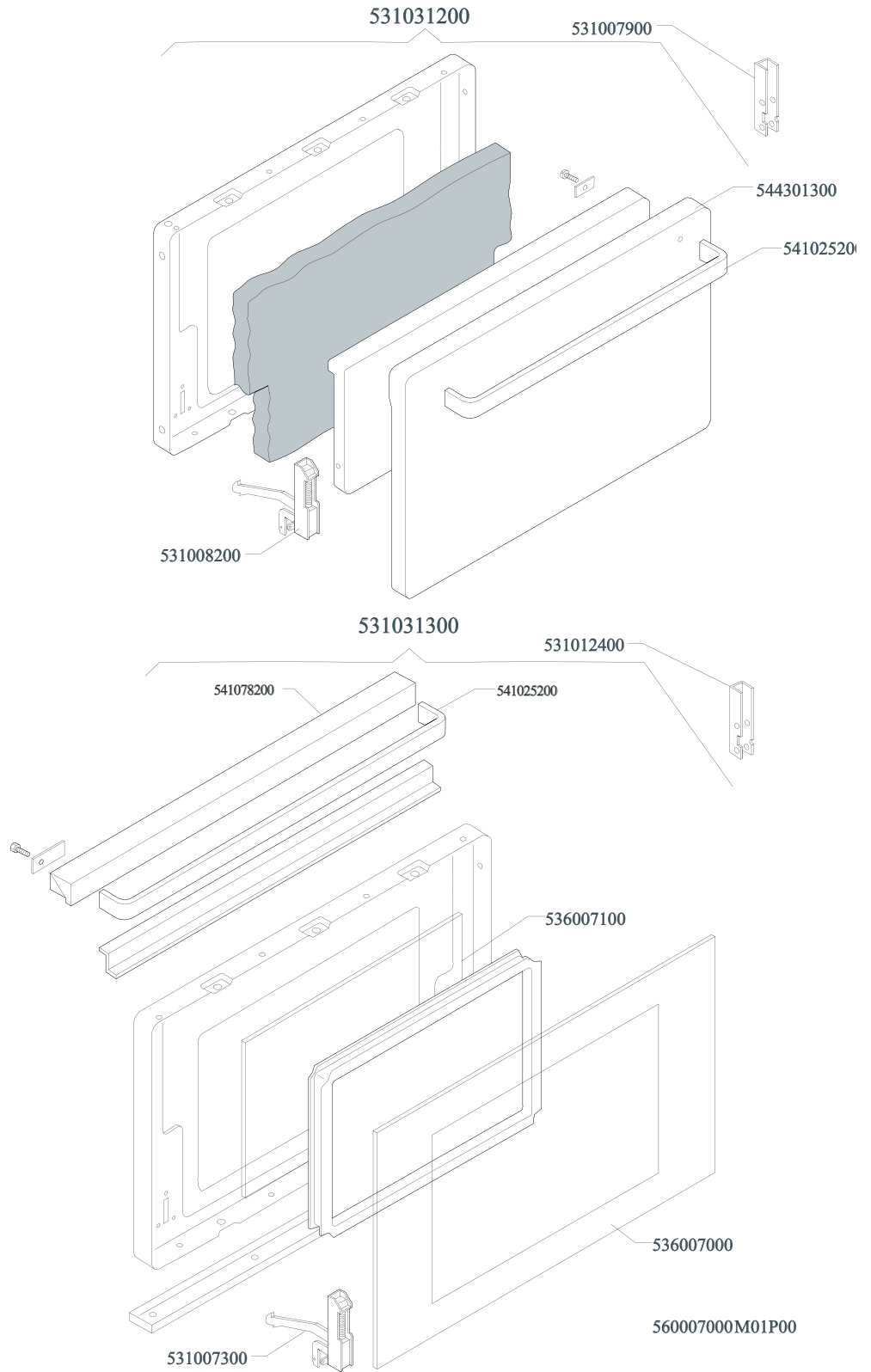



FORNO MAXI PORTA INOX E VETRO S65 - FORNO MATR FINO 0308 PORTE MATR FINO

Codice	Descrizione
531031200	ASS.PORTA FORN.S65 MAXI INOX C.(S)
531007900	PORTARULL.CERN.PORTA CIECA F.MAX(S)
544301300	PORTA FORNO MAXI INOX S65 (S)
541025200	MANIGLIA MAXI PORTA INOX (S)
531008200	CERNIERA PORTA F.MAXI INOX (S)
531031300	ASS.PORTA FORN.S65 MAXI VETR.C.(S)
531012400	PORTARULL.CERN.PORTA F.MAXI (S)
541078200	ASS.SUPP.MANIGLIA PV CF-65 (S)
541025200	MANIGLIA MAXI PORTA INOX (S)
536007100	VETRO I.P.F.S60 MAXI 307X565 (S)
536007000	VETRO E.P.F.S60 MAXI 725X415 SE(S)
531007300	CERNIERA PORTA F.MAXI VETRO (S)