

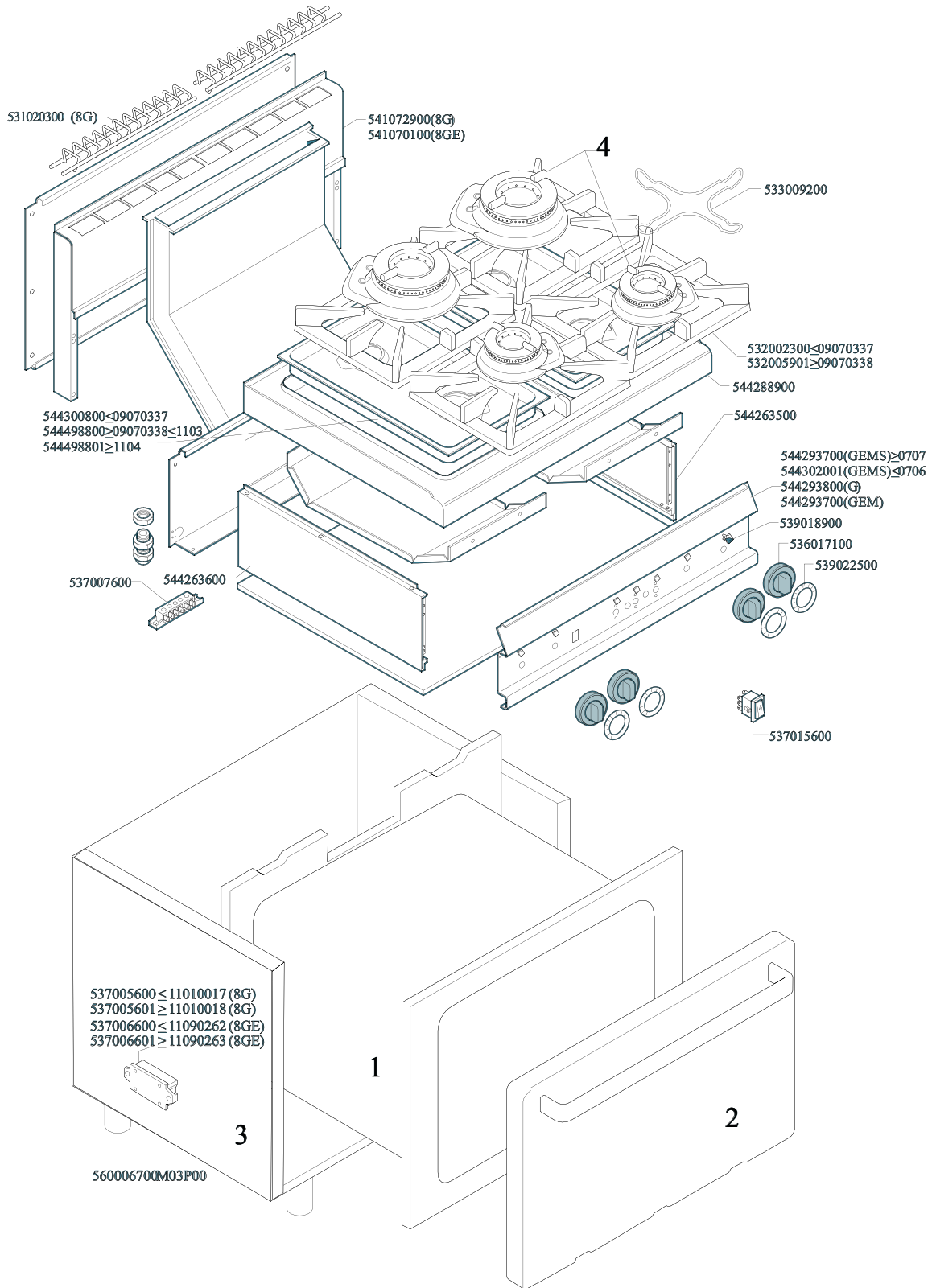

CF4-8G (SN<=0308)
Tav. 560006700M03P00





CF4-8G (SN<=0308) - CUCINE MATR FINO 0308 CF4-8G MATR FINO 0308

| Codice | Descrizione |
|-----------|------------------------------------|
| 531020300 | GRIGLIA SC.FUMI 400 TOND.S65 |
| 541072900 | ASS.DIST.S65 8 FOR. |
| 533009200 | GRIGLIA RID.FUOCHI S65 S70/90 FO |
| 532002300 | GRIGLIA PC S65 344X272 1F.SM.N.(S) |
| 532005901 | GRIGLIA PC S65 340X270 1F.RAF |
| 544288900 | PIANO S65 PC - 8G CF4-8G/GEM |
| 544263500 | FIANCO APP.S65T DX |
| 544300800 | BAC.BRU.S65 PC GN1/1 SM.N.LUC. (S) |
| 544498800 | BAC.BRU.S65 PC GN1/1 SM.N.RAF (S) |
| 544498801 | BAC.BRU.S65 PC GN1/1 AISI 304 |
| 544293800 | CRUSC.S65 CF 4-8G |
| 539018900 | INDICE MAN.C/FRECCIA ROSSA |
| 536017100 | MANOP.Ø70 PEL Ø08X6,5 SEDE PERP. |
| 539022500 | DISC.64.PC-G R. |
| 537007600 | MORSETT.3 POLI 40A VITE-FASTON (S) |
| 544263600 | FIANCO APP.S65T SX |
| 537015600 | P.C.INTERR.IST.NERO FULMINE (S) |
| 537005600 | CENTR.ACC.6FV230V (S) |
| 537005601 | CENTR.ACC.6F.230V |
| - | - |
| - | - |
| - | - |
| - | - |



FORNO MAXI GAS STATICO S65
Tav. 560006900M01P00

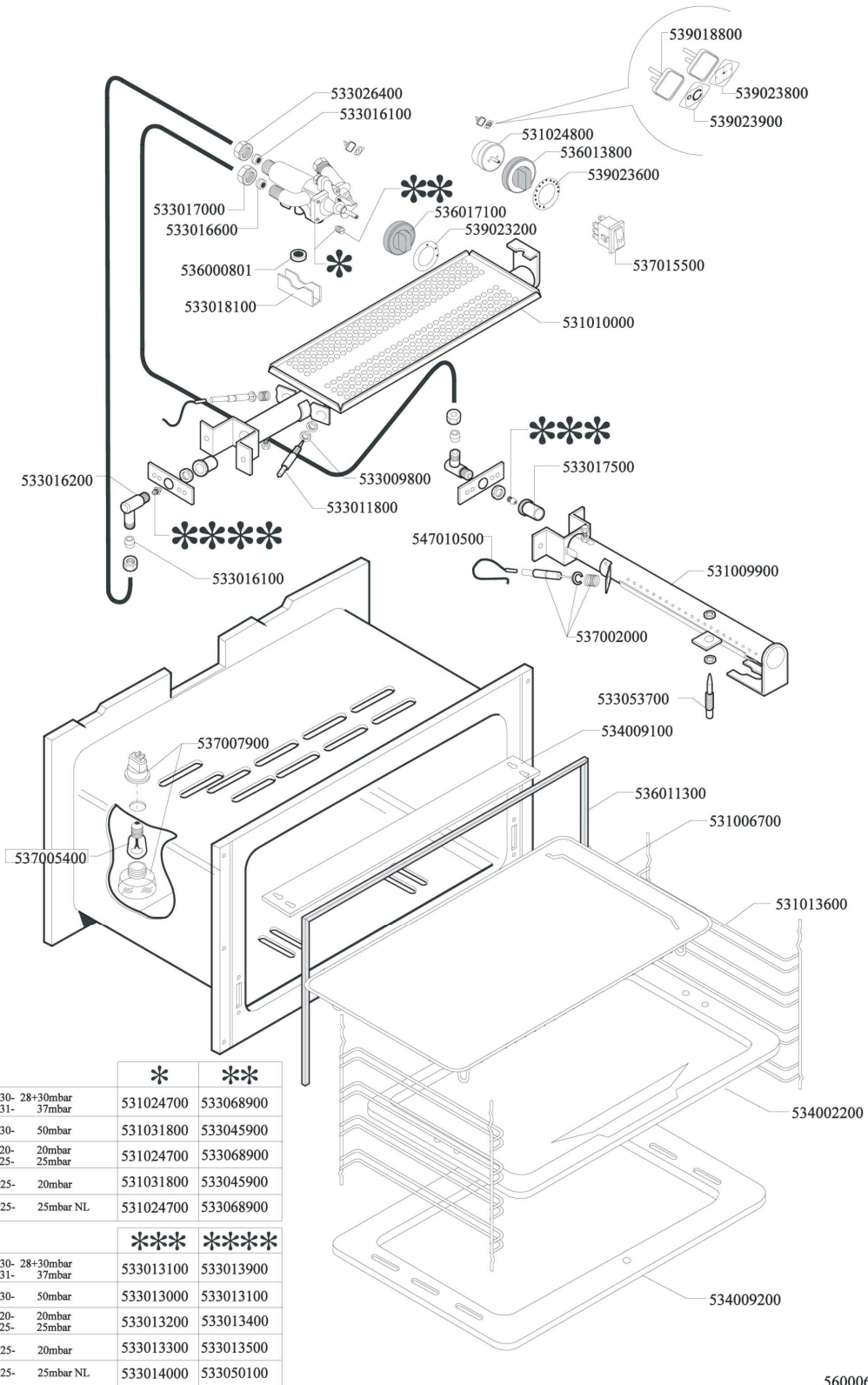



FORNO MAXI GAS STATICO S65 - FORNO MATR FINO 0308 GAS MATR FINO 0308

| Codice | Descrizione |
|-----------|-------------------------------------|
| 539018800 | INDICE MAN.C/VANO ETICHETTA |
| 539023800 | ET.AD.IND.TYMER FORNO |
| 539023900 | ET.AD.IND.TEMPERATURA FORNO |
| 533026400 | RACC.BIC.Ø08 M13X1 |
| 533016100 | BICONO Ø08 |
| 531024800 | TIMER MECCANICO 120' |
| 536013800 | MANOP.Ø70 PEL Ø06X5 SEDE PERP. |
| 539023600 | DISC.64.TYMER MECCANICO |
| 533017000 | DADO ES.X BIC.Ø08 3/8G |
| 533016600 | BICONO RIDUZIONE DA Ø10 A Ø08 |
| 536017100 | MANOP.Ø70 PEL Ø08X6,5 SEDE PERP. |
| 539023200 | DISC.64.FORN.S60 G.ST.RUB.F.G (S) |
| 536000801 | GUARNIZ.ESTERNA SABAF DIS.174-1 |
| 533018100 | BRIGLIA Ø21 |
| 537015500 | P.C.INTERR.LUM.ROSSO LAMPADA (S) |
| 531010000 | BRU.GRILL CF-8/10G (S) |
| 533016200 | RACC.PORTAINIETT.90°F.GAS MAXI (S) |
| 533009800 | DADO ES.M08X1 OT |
| 533017500 | BOCCOLA VENTURI BRU.FORNO CF (S) |
| 533011800 | TC G.M08X1 1200 (S) |
| 533016100 | BICONO Ø08 |
| 547010500 | CAV.AT F.F2,8X0,5-F2,8X0,8 L1300(S) |
| 531009900 | BRU.FORNO CF-8/10G (S) |
| 537002000 | CAND.ACC.FAST.M2,8X0,8 MOLLA 1 (S) |
| 533053700 | TC G.M08X1 1500 (S) |
| 534009100 | PROTEZ.MANOPOLE FORNO MAXI S60 |
| 537007900 | PORTALAMPADA FORNO C/L.S60T/65 |
| 537005400 | LAMP.FORNO 15W 230/240V 300°C (S) |
| 536011300 | GUARNIZ.FORNO MAXI S60 S65 (S) |
| 531006700 | GRIGLIA FORNO MAXI S60/65 (S) |
| 531013600 | PORTAGRIGLIA FORNO MINI (S-I) (S) |
| 534002200 | LECCARDA FORNO MAXI S60/65 (S) |
| 534009200 | SUOLA FORNO MAXI GAS (S) |
| 531024700 | RUB.GAS 6980-1 P.V.BY-P.Ø040 TER(S) |
| 531031800 | RUB.GAS 6980-1 P.V.BY-P.Ø035 TER(S) |
| 531024700 | RUB.GAS 6980-1 P.V.BY-P.Ø040 TER(S) |
| 531031800 | RUB.GAS 6980-1 P.V.BY-P.Ø035 TER(S) |
| 531024700 | RUB.GAS 6980-1 P.V.BY-P.Ø040 TER(S) |
| 533068900 | BY-P.RUB.6980-1/6981-1 Ø40 (S) |
| 533045900 | BY-P.RUB.6980-1/6981-1 Ø35 (S) |
| 533068900 | BY-P.RUB.6980-1/6981-1 Ø40 (S) |
| 533045900 | BY-P.RUB.6980-1/6981-1 Ø35 (S) |
| 533068900 | BY-P.RUB.6980-1/6981-1 Ø40 (S) |
| 533013100 | INIETTORE CH07X08,8 Ø100 (S) |
| 533013000 | INIETTORE CH07X08,8 Ø088 (S) |
| 533013200 | INIETTORE CH07X08,8 Ø155 TV (S) |
| 533013300 | INIETTORE CH07X08,8 Ø170 |
| 533014000 | INIETTORE CH07X08,8 Ø160 |
| 533013900 | INIETTORE CH07X08,8 Ø115 (S) |
| 533013100 | INIETTORE CH07X08,8 Ø100 (S) |
| 533013400 | INIETTORE CH07X08,8 Ø175 TV (S) |
| 533013500 | INIETTORE CH07X08,8 Ø195 (S) |
| 533050100 | INIETTORE CH07X08,8 Ø185 |



FORNO MAXI PORTA INOX E VETRO S65
Tav. 560007000M01P00

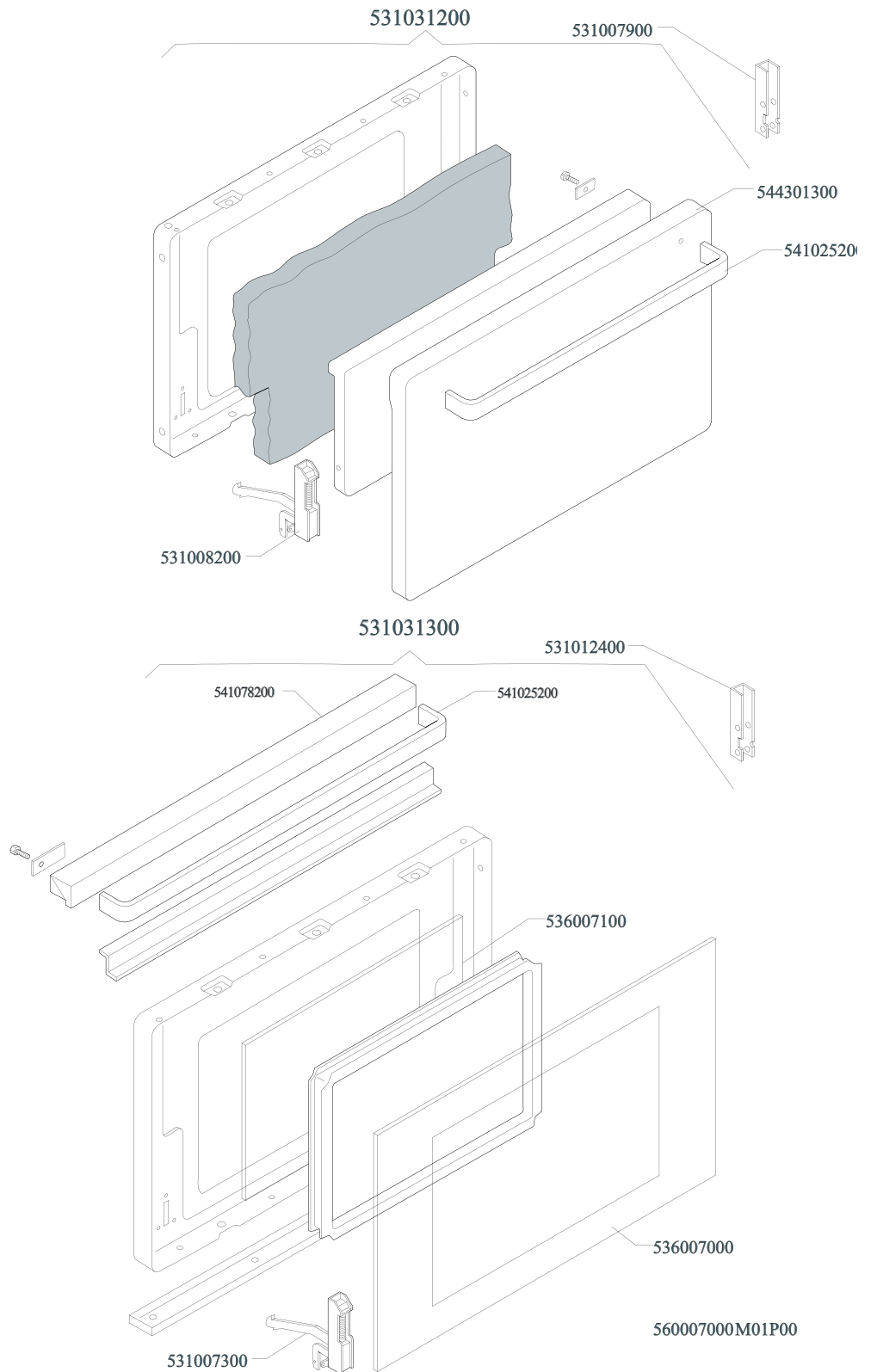



FORNO MAXI PORTA INOX E VETRO S65 - FORNO MATR FINO 0308 PORTE MATR FINO

| Codice | Descrizione |
|-----------|-------------------------------------|
| 531031200 | ASS.PORTA FORN.S65 MAXI INOX C.(S) |
| 531007900 | PORTARULL.CERN.PORTA CIECA F.MAX(S) |
| 544301300 | PORTA FORNO MAXI INOX S65 (S) |
| 541025200 | MANIGLIA MAXI PORTA INOX (S) |
| 531008200 | CERNIERA PORTA F.MAXI INOX (S) |
| 531031300 | ASS.PORTA FORN.S65 MAXI VETR.C.(S) |
| 531012400 | PORTARULL.CERN.PORTA F.MAXI (S) |
| 541078200 | ASS.SUPP.MANIGLIA PV CF-65 (S) |
| 541025200 | MANIGLIA MAXI PORTA INOX (S) |
| 536007100 | VETRO I.P.F.S60 MAXI 307X565 (S) |
| 536007000 | VETRO E.P.F.S60 MAXI 725X415 SE(S) |
| 531007300 | CERNIERA PORTA F.MAXI VETRO (S) |



CARCASSA CF S65
Tav. 560013400M01P00

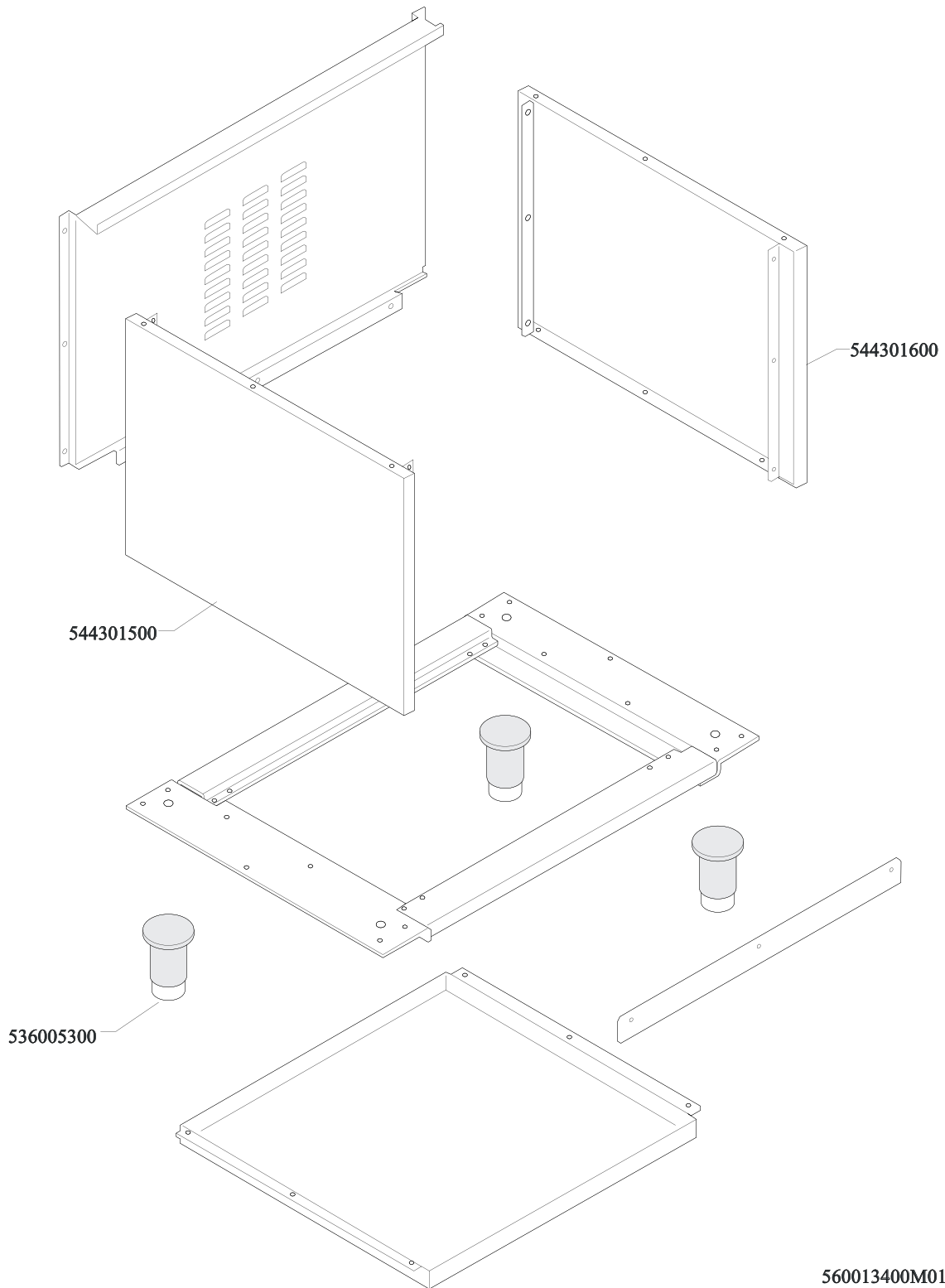



CARCASSA CF S65 - COMPONENTI COMUNI CARCASSA_CF

| Codice | Descrizione |
|-----------|---------------------------------|
| 544301600 | FIANCO APP.S65M CF DX |
| 544301500 | FIANCO APP.S65M CF SX |
| 536005300 | PIEDE Ø2" 120-170 M10 PLAST (S) |



COMANDO E BRUCIATORE PC-G S65 R UR
Tav. 560038100M00P00

| | * | ** |
|-------------------------------|-----------|-----------|
| G30- 28+30mbar G31- 37mbar | 533015400 | 533043400 |
| G30- 50mbar | 533015300 | 533043300 |
| G20- 20mbar G25- 25mbar | 533015200 | 533019400 |
| G25- 20mbar | 533030300 | 533043600 |
| G25- 25mbar NL | 533014900 | 533043500 |

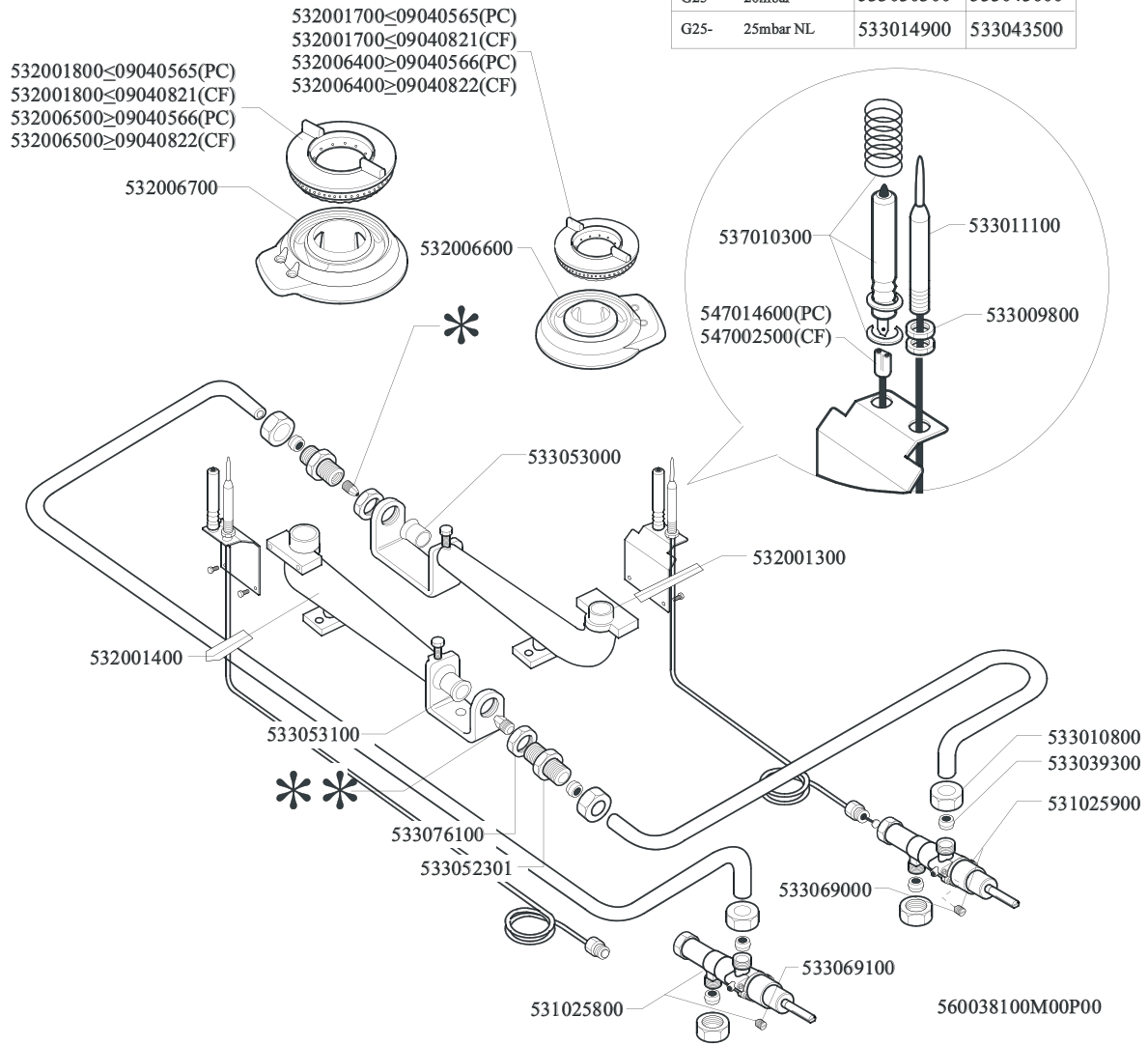



COMANDO E BRUCIATORE PC-G S65 R UR - COMPONENTI COMUNI COMANDO_PC-G

| Codice | Descrizione |
|-----------|----------------------------------|
| 532001700 | SPARTIF.D.CORONA Ø082 S65 (S) |
| 532006400 | SPARTIF.D.CORONA Ø082 3 Z S60T |
| 532001800 | SPARTIF.D.CORONA Ø102 S65 (S) |
| 532006500 | SPARTIF.D.CORONA Ø102 3 Z S60T |
| 532006700 | CORPO BRU.L1 5,5KW C/S S60 NICH |
| 532006600 | CORPO BRU.L1 3,5KW C/S S60 NICH |
| 533011100 | TC G.M08X1 0750 |
| 537010300 | CAND.ACC.FAST.M2,8X0,8 MOLLA 2 S |
| 547014600 | CAV.AT F.F2,8X0,8-TUB.Ø2 L0800 |
| 533053000 | BOCCOLA REG.ARIA Ø18 EST.ALT.38 |
| 532001300 | VENTURI BRU.L1 3,5KW S65 |
| 532001400 | VENTURI BRU.L1 5,5KW S65 |
| 533053100 | BOCCOLA REG.ARIA Ø20 EST.ALT.38 |
| 533076100 | BOCCOLA CENTR.Ø20 (S) |
| 533052301 | RACC.PORTAINIETT. 0°CANN.Ø10 |
| 533010800 | DADO ES.X BIC.Ø10 M16X1,5 |
| 533039300 | BICONO Ø10 |
| 531025900 | RUB.GAS 20S P.V.BY-P.Ø070 |
| 533069000 | BY-P.RUB.20S-21S Ø070 |
| 533069100 | BY-P.RUB.20S-21S Ø060 |
| 531025800 | RUB.GAS 20S P.V.BY-P.Ø060 |
| 533015400 | INIETTORE CH12X14,0 Ø093 |
| 533015300 | INIETTORE CH12X14,0 Ø082 |
| 533015200 | INIETTORE CH12X14,0 Ø145 |
| 533030300 | INIETTORE CH12X14,0 Ø160 |
| 533014900 | INIETTORE CH12X14,0 Ø150 |
| 533043400 | INIETTORE CH12X14,0 Ø117 |
| 533043300 | INIETTORE CH12X14,0 Ø103 |
| 533019400 | INIETTORE CH12X14,0 Ø180 |
| 533043600 | INIETTORE CH12X14,0 Ø200 |
| 533043500 | INIETTORE CH12X14,0 Ø190 |