

**ATTENZIONE:** PER TENSIONI SPECIALI, SPECIFICARE SEMPRE IL MODELLO DI FORNO ED IL NUMERO DI MATRICOLA  
**ATTENTION:** FOR SPECIAL VOLTAGES, PLEASE ALWAYS SPECIFY THE OVEN MODEL AND THE SERIAL NUMBER

**ATTENTION:** POUR TENSIONS SPÉCIALES, MERCI DE SPÉCIFIER TOUJOURS LE MODÈLE DU FOUR ET LE NUMÉRO DE SÉRIE  
**ACHTUNG:** BEI SONDRERSPANNUNGEN, BITTE IMMER OFEN-MODELL UND SERIENNUMMER GEBEN.

ed. 0713

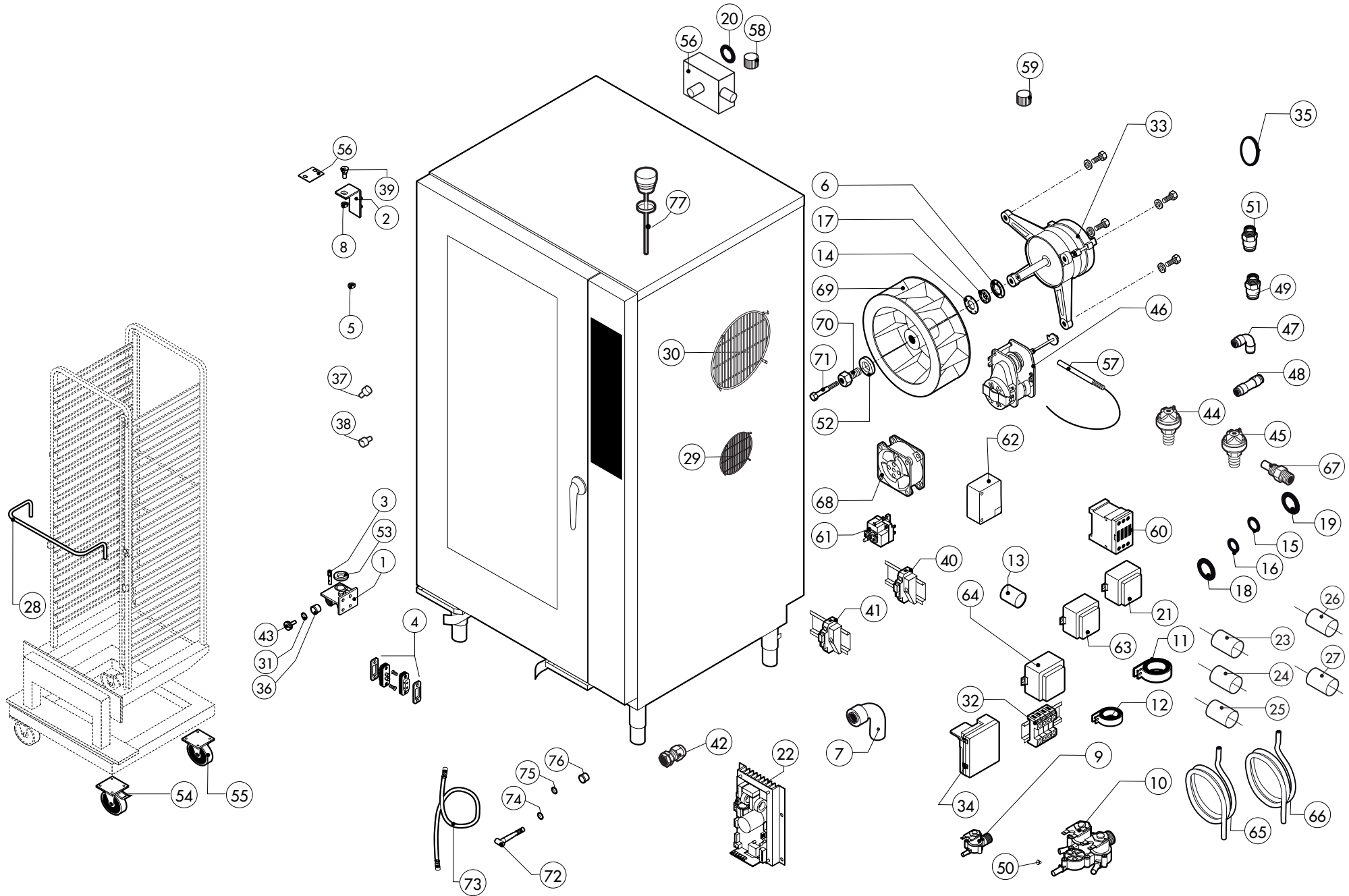

**ATTENZIONE:** PER ORDINARE I RICAMBI, SPECIFICARE SEMPRE IL MODELLO DI FORNO ED IL NUMERO DI MATRICOLA  
**ATTENTION:** WHEN ORDERING SPARE PARTS, PLEASE ALWAYS SPECIFY THE OVEN MODEL AND THE SERIAL NUMBER

**ATTENTION:** POUR COMMANDER DES PIÈCES, MERCI DE SPECIFIER TOUJOURS LE MODÈLE DU FOUR ET LE NUMÉRO DE SÉRIE  
**ACHTUNG:** UM ERSATZTEILE ZU BESTELLEN, BITTE IMMER OFEN-MODELL UND SERIENNUMMER GEBEN.

ed. 0713

POS.	COD.	Pz.	DESCRIZIONE	DESCRIPTION	DESCRIPTION	BESCHREIBUNG	DESCRIPCIÓN
1	R11205390	1	ASS.CERNIERA INFERIORE M-V/201-202	LOWER DOOR HINGE	CHARNIERE INFERIEURE PORTE	UNTERES SCHARNIER	BISAGRA INFERIOR
2	R11426830	1	CERNIERA SUPER.PORTA SR.2013	UPPER DOOR HINGE	CHARNIERE SUPERIEURE PORTE	OBERES SCHARNIER	BISAGRA SUPERIOR
3	R58002540	1	CHIAVETTA X PERNO C/FERMO PORTM-V/120-22	DOOR PIVOT SUNK KEY	CLAVETTE POUR CHEVILLE PORTE	KEIL F. TUERSTIFT	LLAVE PARA PERNO PUERTA
4	R65260752	1	CONTATTO PER LUCI SR.2014+FORNI A PAVIM.	LAMPS CONTACT BLOCK	CONTACT ECLAIRAGE	LICHTKONTSCHALTER	CONTACTO PARA LUZ
5	R65240020	1	CONTRODADO PG 116/16/NY	CABLE GLAND LOCK NUT	CONTRE-ECROU POUR RONDELLE FIXATION	MUTTER	CONTRODADO PASACABLE
6	R58003850	2	CONTROFLANGIA GUARN.GRANDE	MOTOR GASKET BRASS COUNTER FLANGE	CONTRE- BRIDE JOINT MOTEUR	GEGENFLANSCH F. MOTORDICHTUNG	CONTRABRIDA JUNTA MOTOR
7	R62280038	1	CURVA C/MORSET.HTS-HTSW X TUBO D.50 D.50X	CURVE WITH TERMINAL	COURBE AVEC BORNIER	KURVE MIT KLEMM	CURVA CON REGLETERA
8	R58004050	1	DADO PER PERNO CERNIERA REG. M/106-220	NUT FOR UPPER DOOR HINGE	ECROU CHEVILLE CHARNIERE SUPERIEURE	MUTTER F. OBERES SCHARNIERSTIFT	TUERCA PARA PERNO BISAGRA SUPERIOR
9	R65110200	1	E.V. 1 VIA 220V 50HZ X J.G.CON ATTACC	SOLENOID VALVE	ELECTROVANNE	MAGNETVENTIL	ELECTROVALVULA
10	R65110240	1	E.V. 3VIE 2P+1D 220V/50HZ J.G.CON ATTACC	SOLENOID VALVE 220V 50HZ	ELECTROVANNE 220V 50HZ	MAGNETVENTIL 220V 50HZ	ELECTROVALVULA 220V 50HZ
11	R65280490	1	FERRITE TOROIDALE FT36	FERRITE FT36	FERRITE FT36	FERRIT FT36	FERRITA FT36
12	R65280480	2	FERRITE TOROIDALE FT25	FERRITE FT25	FERRITE FT25	FERRIT FT25	FERRITA FT25
13	R65280240	1	FILTRO FLC470501F	INTERFERENCE SUPPRESSOR	FILTRE ANTIPARASITES	STOERSCHUTZFILTER	FILTRO
14	R58003840	2	FLANGIA GUARN.GRANDE	MOTOR GASKET BRASS FLANGE	BRIDE JOINT MOTEUR	FLANSCH F. MOTORDICHTUNG	BRIDA JUNTA MOTOR
15	R70010030	1	GUARNIZIONE OR 6,07 X 1,78 SILICONE	GASKET 6,07 X 1,78	JOINT 6,07 X 1,78	RINGDICHTUNG 6,07 X 1,78	VIDRIO OR 6,07 X 1,78
16	R70010050	1	GUARNIZIONE OR 7,60 X 2,62 OR 3030 NB	GASKET	JOINT	DICHTUNG	JUNTA
17	R70020050	2	GUARNIZIONE MARK IV MLA 2400.02.05	GASKET	JOINT	DICHTUNG	JUNTA
18	R70010210	1	GUARNIZIONE OR NBR 70 18,72x2,62 C.3075	GASKET	JOINT	DICHTUNG	JUNTA
19	R65070230	1	GUARNIZIONE PER TERM.SIC.CA-MERM/106-110	GASKET	JOINT	RINGDICHTUNG	JUNTA
20	R70050150	1	GUARNIZIONE X TAPPO 2" PLAST. G40005	GASKET	JOINT	RINGDICHTUNG	JUNTA
21	R65450200	1	INDUTTANZA 6,5 mH 8A	INDUCTANCE	INDUCTANCE	INDUKTANZ	INDUCTANCIA
22	R65140890	1	INVERTER 0.5KW MOT.INF.A001M005XSB X RIC	INVERTER	INVERSEUR	INVERTER	INVERSOR
23	R62090713	1	MANICOTTO FF 3/4"-1/2" OT	COUPLING	MANCHON	MUFFE	FUNDA
24	R62030118	1	MANICOTTO RIDUZ.F.1/8-1/4 CIL. PRDI222100	1/8"-1/4" FEMALE REDUCTION COUPLING	MANCHON REDUCTION 1/8" - 1/4"	REDUZIERMUFFE 1/8" - 1/4" F	MANGUITO REDUCCION HEMBRA 1/8"-1/4"
25	R70060080	1	MANICOTTO SILICONE D.13X18X80	SILICON SLEEVE	SILICONE SLEEVE	SILIKONHÜLLE	FUNDA DE SILICONA
26	R70060020	1	MANICOTTO SILICONE D.30X35X9 TAPPO SFA	SILICON SLEEVE	SILICONE SLEEVE	SILIKONHÜLLE	FUNDA DE SILICONA
27	R70060040	2	MANICOTTO SILICONE D.50X50X3	SILICON SLEEVE	SILICONE SLEEVE	SILIKONHÜLLE	FUNDA DE SILICONA
28	R10457840	1	MANIGLIA CARRELLO KS/021-040	HANDLE FOR TROLLY	POIGNÉE POUR CHARIOT PORTE POELES	HANDGRIFF-LAUFKATZE	MANIJA CARRO PORTABANDEJAS
29	R75300020	3	MASCHERINA VENTILATORE D.120 PER VENT.	FAN GUARD GRID D.120	GRILLE VENTILATEUR D.120	VENTILATORSCHUTZGITTER D.120	REJILLA VENTILADOR D.120
30	R75300090	2	MASCHERINA VENTILATORE D.350	FAN GUARD GRID D.350	GRILLE VENTILATEUR D.350	VENTILATORSCHUTZGITTER D.350	REJILLA VENTILADOR D.350
31	R61620091	16	MOLLA A TAZZA D.14/6,4X0,8 C70.	BELLEVILLE WASHER Ø 14/6.4	RESSORT A DISQUE Ø 14/6.4	TELLERFEDER Ø 14/6.4	MUELLE A DISCO Ø 14/6.4
32	R65220280	1	MORSETTIERA MONOFASE C/TERRA PAS-SANTE	TERMINAL BOARD	BORNIER	KLEMMLEISTE	REGLETERA
33	R65040530	2	MOTORE KW 055 F3 4P 3039 200-440V I	MOTOR	MOTEUR	MOTOR	MOTOR
34	R63060160	2	PANNELLO ACCENS. S4565C1116B Ts=5 Tps=1	DAMPER SYSTEM	SORTIE EVAPORATION MOUFLE	DAMPFABLASS-STELLMOTOR	MOTOR RESPIRADERO COMPLETO
35	R70010130	1	GUARNIZIONE SILICONE ROSSO 80X50 3X3	RED GASKET	JOINT ROUGE	ROTEN DICHTUNG	JUNTA ROJA
36	R58002550	1	PATTINO FERMO PORTA M-V/120- 220	DOOR RETAINER GUIDE SHOE	PATIN ARRET PORTE	GLEITSTUECK F. TUEARRETIERUNG	PATILLA CIERRE PUERTA

**ATTENZIONE:** PER ORDINARE I RICAMBI, SPECIFICARE SEMPRE IL MODELLO DI FORNO ED IL NUMERO DI MATRICOLA  
**ATTENTION:** WHEN ORDERING SPARE PARTS, PLEASE ALWAYS SPECIFY THE OVEN MODEL AND THE SERIAL NUMBER

**ATTENTION:** POUR COMMANDER DES PIÈCES, MERCI DE SPECIFIER TOUJOURS LE MODÈLE DU FOUR ET LE NUMÉRO DE SÉRIE  
**ACHTUNG:** UM ERSATZTEILE ZU BESTELLEN, BITTE IMMER OFEN-MODELL UND SERIENNUMMER GEBEN.

ed. 0713

POS.	COD.	Pz.	DESCRIZIONE	DESCRIPTION	DESCRIPTION	BESCHREIBUNG	DESCRIPCIÓN
37	R58003140	2	PERNO AGGANCIAMENTO DEFLETTORE	FAN GUARD PANEL PIN	PIVOT DEFLECTEUR	BOLZEN FÜR LUFTLEITBLECH	PERNO CIERRE DEFLECTOR
38	R58000160	2	PERNO FISS. DEFLETTORE K_081-101-A20-201	FAN GUARD PANEL PIN	PIVOT DEFLECTEUR	BOLZEN FÜR LUFTLEITBLECH	PERNO CIERRE DEFLECTOR
39	R58002150	1	PERNO SUP.CERNIERA REG. M/106-220	UPPER HINGE PIN	CHEVILLE CHARNIERE SUPERIEURE	OBERES SCHARNIERSTIFT	PERNO SUPERIOR BISAGRA
40	R65210020	5	PORTAFUSIBILE BARRA DIN 5x20	FUSE CARRIER	PORTE-FUSIBLE	SICHERUNGSHALTER	PORTAFUSIBILE
41	R65210050	2	PORTAFUSIBILE BARRA DIN 6,3x32	FUSE CARRIER	PORTE-FUSIBLE	SICHERUNGSHALTER	PORTAFUSIBILE
42	R65240010	1	PRESSACAVO PG 107 Z/16	FAIRLEAD	PRESSE CABLE	ZUGENTLASTUNG	PRENSACABLES
43	R58002560	1	PRESSORE FERMO PORTA M-V/120-220	SCREW FOR LOWER DOOR HINGE	VIS POUR CHARNIERE INFERIEURE	DRUCKSCHRAUBE F. UNTERERS TUERSCHARNIER	TORNILLO PARA BISAGRA INFERIOR
44	R63070050	1	PRESSOSTATO 1/8" 0,5-0,35 BAR PH/91140	WATER SAFETY PRESSURE SWITCH	INT.A PRESSION SEC.-EAU	WASSER-DRUCKWACHTER	PRESOSTATO AQUA
45	R63070010	1	PRESSOSTATO PG 901.61	GAS SAFETY PRESSURE SWITCH	INT.A PRESSION SECURITE-GAZ	DRUCKSCHALTER PG	PRESOSTATO GAS
46	R65090220	1	PROGRAMMAT. 1 CAMME V220/50HZ 1 CIRCUITO	DAMPER SYSTEM	SORTIE EVAPORATION MOUFLE	DAMPFABLASS-STELLMOTOR	MOTOR RESPIRADERO COMPLETO
47	R62090478	1	RACC. INTERMEDIO A GOMITO D.10 PM0310E	ELBOW PIPE FITTING	COURBE AVEC QUEUE	STUCK MIT SCHAFT	RACOR CON CODO
48	R62090458	3	RACC. INTERMEDIO DIRITTO D.10 PM0410E	PIPE FITTING	COURBE	STUCK	RACOR
49	R62090508	1	RACC.TERMIN.DIR.FIL.CON.10X1/4 PM011002E	10X1/4 STRAIGHT THREADED TERMINAL PIPE FITTING	RACCORDEMENT	ENDVERBINDUNGSSTUCK 10 X 1/4" GESCHNITTEN	RACOR
50	R65110510	2	REGOL. PORTATA ROSSO ALPHATECH. 15LT/H	1.5 LT/H WATER FLOW REDUCER	REGULATUER DE DEBIT 15 LT.	DURCHFLUSSMONDERER 15 L/STD.	REGULADOR DE CAUDAL 15 LT.
51	R62090723	1	RIDUZIONE MF 1/2"-1/4" OT	REDUCTION	REDUCTION	VERRINGERUNG	REDUCCION
52	R58004010	2	ROND.FISS.VENTOLA D 30/12.5	FAN WASHER Ø 30/12.5	RONDELLE TURBINE Ø 30/12.5	UNTERLEGSCHLEIBE Ø 30/12.5	ARANDELA FIJACION TURBINA Ø 30/12.5
53	R58002570	1	RONDELLA 30/15X3 M-V/120-220	WASHER Ø 30/15X3 M-V/120-220	RONDELLE Ø 30/15X3 M-V/120-220	UNTERLEGSCHLEIBE Ø 30/15X3 M-V/120-220	ARANDELA Ø 30/15X3 M-V/120-220
54	R69090360	2	RUOTA GIR.DOPPIA C/FR. D.100 (5945UAP100)	WHEEL	ROUE	RAD	RUEDA
55	R69090350	2	RUOTA GIR.DOPPIA D.100 (5940UAP100)	WHEEL	ROUE	RAD	RUEDA
56	R69180100	1	SCATOLA COND.SCARICO H/MV 061-101-201	QUENCHING-DRAIN COLLECTOR	BOITE DE CONDENSATION DECHARGE	KONDENSATION-ABFLUSS SCHACHTEL	CAJON CONDENSACION-DESAGÜE
57	R65320220	3	SONDA "K" 6X80 1,5ML. TESTA RASTREM.20mm	PROBE "K" 6X80 1,5ML.	SONDE "K" 6X80 1,5ML.	FUEHLER "K" 6X80 1,5ML.	SONDA "K" 6X80 1,5ML.
58	R69150100	1	TAPPO FEMMINA G 2" PP+25%FV NERO	COVER	BOUCHON	ABDECKUNG	TAPON
59	R62100108	1	TAPPO ROSSO D.10 (PM0810R)	COVER	BOUCHON	ABDECKUNG	TAPON
60	R65140380	1	TELERUTTORE 3RT1016-1AP02	CONTACTOR	CONTACTEUR	SCHUETZ	CONTACTOR
61	R65070350	1	TERMOSTATO SICUR. 360°C -25K 55.32572.8	THERMOSTAT	THERMOSTAT	THERMOSTAT	TERMOSTATO
62	R65180270	2	TRASF. ACCENS. COFI TRK2-3PVD	IGNITION TRANSFORMER	TRANSFORMATEUR D'ALLUMAGE	ZÜNDTRANSFORMATOR	TRANSFORMADOR DE ENCENDIDO DESDE
63	R65180420	2	TRASF.RE 20VA 0-220-240/12V MOD.163.16	TRANSFORMER 20VA	TRANSFORMATEUR 20VA	TRANSFORMATOR 20VA	TRANSFORMADOR 20VA
64	R65180430	1	TRASF.RE 40VA 0-220-240/12V MOD.163.82	TRANSFORMER 40VA	TRANSFORMATEUR 40VA	TRANSFORMATOR 40VA	TRANSFORMADOR 40VA
65	R80150000	4	TUBO PE 10MMX7 AZZURRO PM950612E	BLUE PIPE	TUBE	LEITUNG	TUBO
66	R80120060	5	TUBO SILIC. TRASP.SR60/TR 7/12.	BLUE PIPE	TUBE	LEITUNG	TUBO
67	R58006160	2	UGELLO COND.D.0,8 CODOLO CIL.10	NOZZLE	BEC	DÜSE	BOQUILLA
68	R65060050	4	VENTILATORE COMPATTO D.120 4715MS 23T	COMPONENTS VENTILATION MOTOR	MOTEUR DE REFRROIDISSEMENT	ABKÜHLUNGS MOTOR	MOTOR DE ENFRIAMIENTO
69	R75400440	2	VENTOLA D.350X114/12 50HZ P.D.	FAN	TURBINE	LUEFTERRAD	PALA VENTILADOR
70	R58004000	2	VITE FISS.VENTOLA M/12X1.5 SX	FAN SCREW M12x1.5 SX	VIS DE BLOCAGE TURBINE M12x1.5 SX	VENTILATORSCHRAUBE M12x1.5 SX	TORNILLO FIJACION TURBINA M12x1.5 SX
71	R61020562	2	VITE TE A2 M 6X55 UNI 5737	MOTOR SCREW TE A2 M6x55	VIS DE BLOCAGE MOTEUR TE A2 M6x55	MOTORSCHRAUBE TE A2 M6x55	TORNILLO MOTOR TE A2 M6x55
72	R62200028	1	LANCIA DI LAVAGGIO SENZA TUBO	SHOWER HANDLE	POIGNEE DOUCHETTE	GRIFF F. HANDBRAUSE	MANGO DUCHA
73	R62200058	1	GOMMA 1/2"X1/2"X2.5M LANCIA L.2500 MM	FLEXIBLE PIPE SHOWER	TUBE FLEXIBLE DOUCHETTE	SCHLAUCH FUER HANDBRAUSE	TUBO FLEXIBLE DUCHA
74	R70030040	2	GUARNIZIONE D.16X24 3/4 GOMMA.	GASKET D.16X24 3/4	JOINT D.16X24 3/4	DICHTUNG D.16X24 3/4	JUNTA D.16X24 3/4
75	R70030030	1	GUARNIZIONE D. 11X19 1/2"	GASKET D. 11X19 1/2"	JOINT D. 11X19 1/2"	DICHTUNG D. 11X19 1/2"	JUNTA D. 11X19 1/2"
76	R69180300	1	SUPPORTO IN PLASTICA X DOCCIONE ESTERNO	HOLDER	SUPPORT	GESTELL	SOPORTE
77	R10100140	1	TAPPO SFIATO COMPLETO M/106-220	COVER	BOUCHON	ABDECKUNG	TAPON

**TAV. A**

**KVG 201 X**

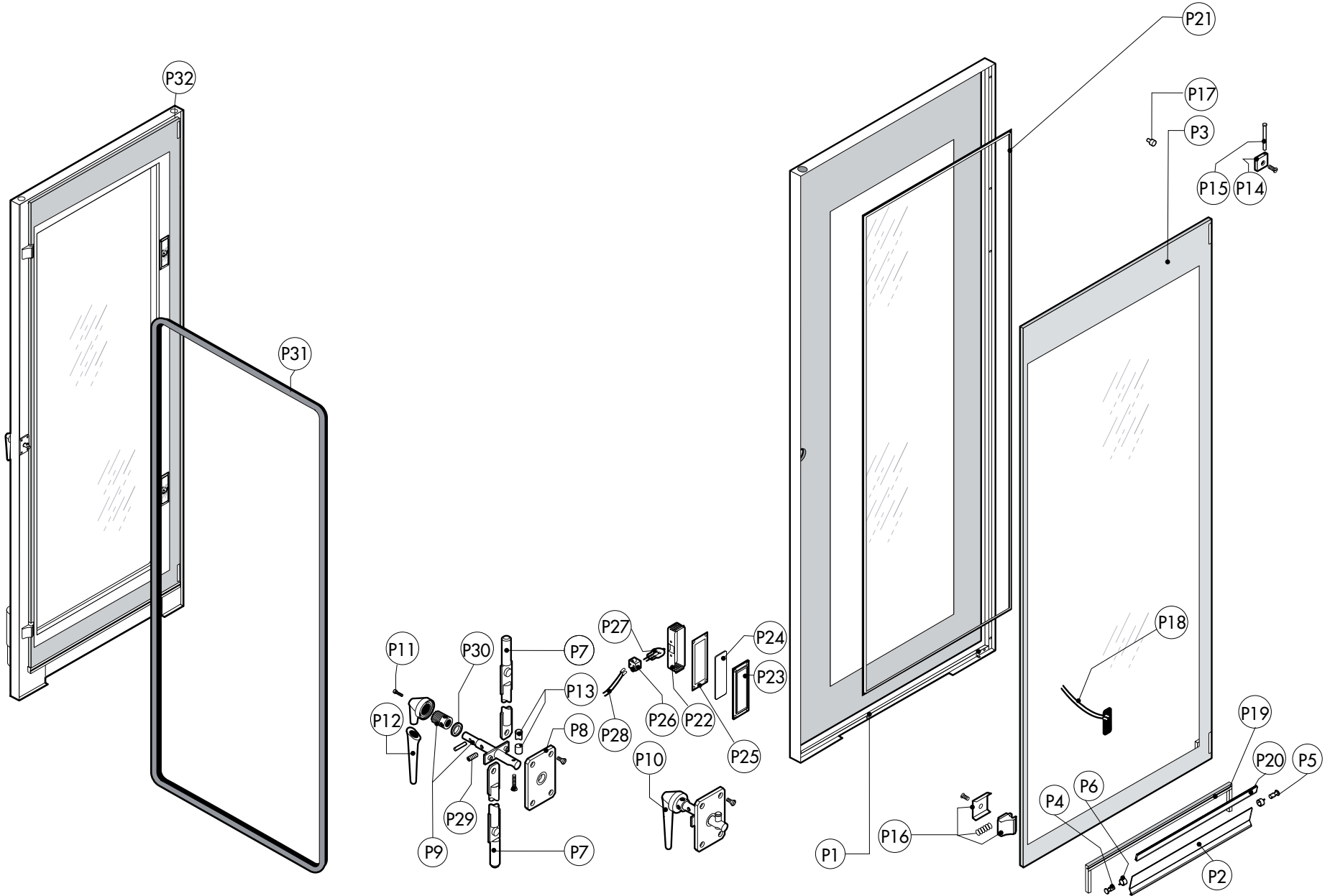



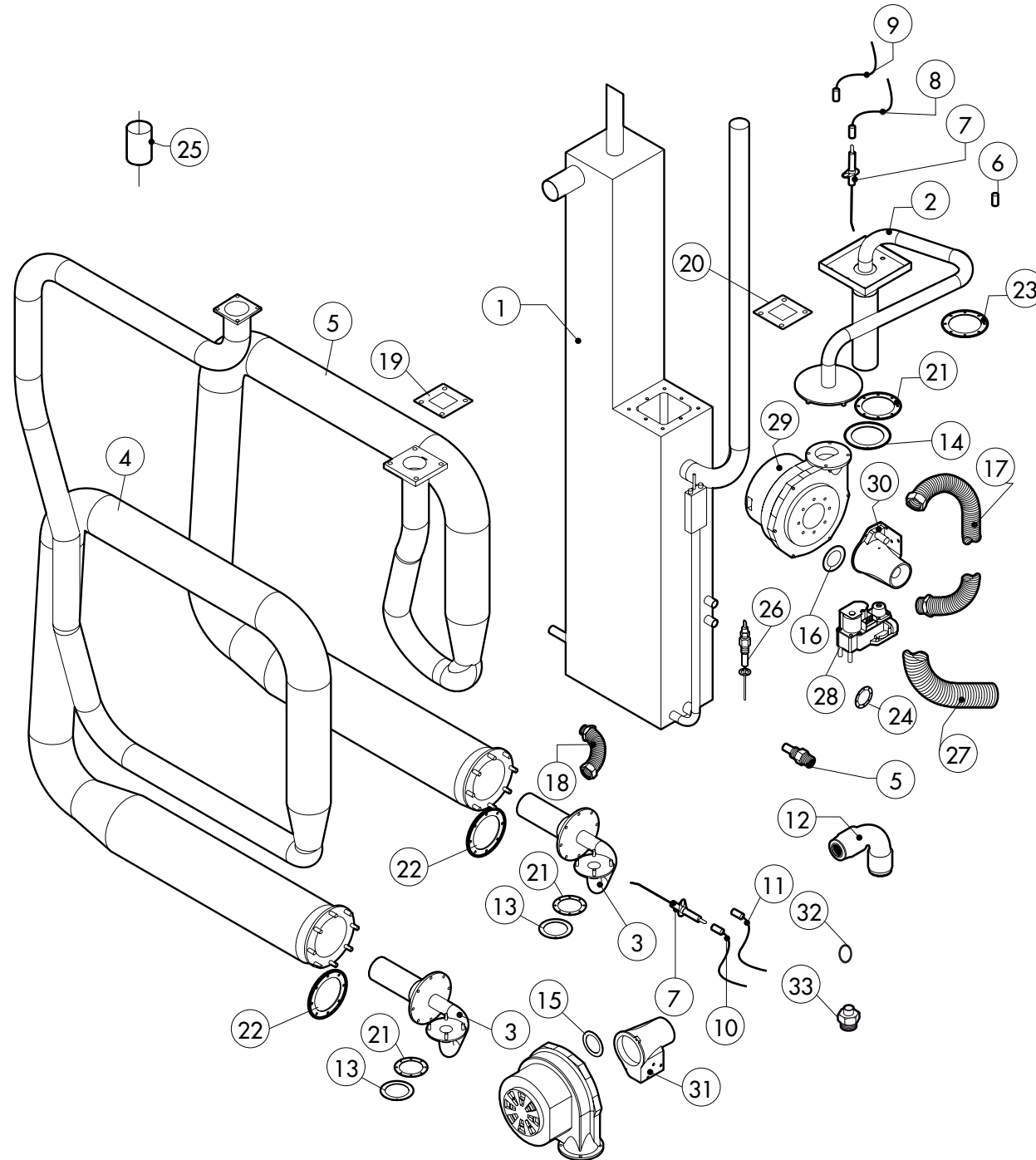



POS.	COD.	Pz.	DESCRIZIONE	DESCRIPTION	DESCRIPTION	BESCHREIBUNG	DESCRIPCIÓN
1	R11208870	1	ASS.BOILER C/CAL-OUT KMG201	STEAM GENERATOR ASSEMBLY	CHAUDIERE COMPLETE	DAMPFERZEUGER KOMPLETT	BOILER COMPLETO
2	R18210582	1	ASS.BRUCIATORE BOILER XMG102/HMG201	COOKING CABINET BURNER	BRÛLEUR MOUFLE	BOILERBRENNER	QUEMADOR BOILER
3	R11218002	2	ASS.BRUCIATORE CAMERA HMG101	COOKING CABINET BURNER	BRÛLEUR MOUFLE	GARRAUMBRENNER	QUEMADOR CAMERA
4	R11208860	1	ASS.SCAMBIATORE.CAM.INF. K_G201	HEAT EXCHANGER ACCESSORIES INCLUDED	ECHANGEUR CHALEUR ET ACCESSOIRES	WÄRMETAUSCHER KOMPLETT MIT ZUBEHÖR	INTERCAMBIADOR COMPLETO CON ACCESORIOS
5	R11208850	1	ASS.SCAMBIATORE.CAM.SUP.K_G201	HEAT EXCHANGER ACCESSORIES INCLUDED	ECHANGEUR CHALEUR ET ACCESSOIRES	WÄRMETAUSCHER KOMPLETT MIT ZUBEHÖR	INTERCAMBIADOR COMPLETO CON ACCESORIOS
6	R58001480	9	BOCCOLA FISSAGGIO CANDELETTE	BUSH	DOUILLE	BUSCH	CASQUILLO
7	R63050130	9	CANDELA ACCENSIONE A/SM ø9.5 KA1 ø3/M4	IGNITOR	BOUGIE ALLUMAGE	ZUENDKERZE	BUJIA ENCENDIDO
8	R66605801	1	CAVO ACC./RIL.CAM./BOIL. L=700 2 CAVI	FLAME IGNITION CABLE/FLAME SENSOR CABLE	CABLE ALLUMAGE/CONTROLE FLAME	ZUENDKABEL/FLAMMUEBERWACHUNGSKABEL	CABLE ENCENDIDO/SENSOR
9	R66605821	2	CAVO ACC./RIL.CAM./BOIL. L=300 2 CAVI	FLAME IGNITION CABLE/FLAME SENSOR CABLE	CABLE ALLUMAGE/CONTROLE FLAME	ZUENDKABEL/FLAMMUEBERWACHUNGSKABEL	CABLE ENCENDIDO/SENSOR
10	R66605140	2	CAVO ACCENS.C/CONNETT.A 90° D.6,3 L=400	FLAME IGNITION CABLE/FLAME SENSOR CABLE	CABLE ALLUMAGE/CONTROLE FLAME	ZUENDKABEL/FLAMMUEBERWACHUNGSKABEL	CABLE ENCENDIDO/SENSOR
11	R66605120	1	CAVO ACCENS.C/CONNETT.A 90° D.6,3 L=800	FLAME IGNITION CABLE/FLAME SENSOR CABLE	CABLE ALLUMAGE/CONTROLE FLAME	ZUENDKABEL/FLAMMUEBERWACHUNGSKABEL	CABLE ENCENDIDO/SENSOR
12	R62280078	3	CURVA POLYPR.HTB DN50 87,5° DIN EN1451-1	CURVE	COURBE	KURVE	CURVA
13	R11430350	2	DIAFRAMMA VENTILATORE/BRUCIATORE D.18	ORIFICE D.18	DIAPHRAGME D.18	BLLENDE D.18	DIAFRAGMA D.18
14	R11430340	1	DIAFRAMMA VENTILATORE/BRUCIATORE D.22	ORIFICE D.22	DIAPHRAGME D.22	BLLENDE D.22	DIAFRAGMA D.22
15	R58004190	2	DISCO CALIBRATO ø4 mm	ORIFICE ø4 mm	DIAPHRAGME ø4 mm	BLLENDE ø4 mm	DIAFRAGMA ø4 mm
16	R58004200	1	DISCO CALIBRATO ø4,5 mm	ORIFICE ø4,5 mm	DIAPHRAGME ø4,5 mm	BLLENDE ø4,5 mm	DIAFRAGMA ø4,5 mm
17	R62180152	2	FLEX GAS L=100 CM M/F1/2" INOX	GAS INLET FLEXIBLE PIPE	TUBE FLEXIBLE ENTREE GAZ	FLEXROHR GASZULAUF	TUBO FLEXIBLE ENTRADA GAS
18	R62180132	1	FLEX GAS L=50 CM M/F1/2" INOX	GAS INLET FLEXIBLE PIPE	TUBE FLEXIBLE ENTREE GAZ	FLEXROHR GASZULAUF	TUBO FLEXIBLE ENTRADA GAS
19	R63140060	1	GUARN. BRUC.-SCAMB. X BRUC. 18-27 KW	BURNER/HEAT EXCHANGER GASKET	JOINT BRULEUR / ECHANGEUR CALORIFIQUE	DICHTUNG BRENNER/WARMETAUSCHER	JUNTA QUEMADOR/INTERCAMBIADOR
20	R63140010	4	GUARN.BOIL.-COND.FUMI VM-G/061.	GASKET	JOINT	DICHTUNG	JUNTA
21	R63140050	6	GUARN.VENTILATORE-BRUCIATORE	BURNER/FAN MOTOR GASKET	JOINT VENTILATEUR / BRULEUR	DICHTUNG GEBLASE/GASBRENNER	JUNTA VENTILADOR/QUEMADOR
22	R63140080	4	GUARNIZIONE SCAMB.-BRUC. De.126 18-27kW	BURNER/HEAT EXCHANGER GASKET	JOINT BRULEUR / ECHANGEUR CALORIFIQUE	DICHTUNG BRENNER/WARMETAUSCHER	JUNTA QUEMADOR/INTERCAMBIADOR
23	R63140070	1	GUARNIZIONE SCAMB.-BRUC. De.84 9kW	BURNER/HEAT EXCHANGER GASKET	JOINT BRULEUR / ECHANGEUR CALORIFIQUE	DICHTUNG BRENNER/WARMETAUSCHER	JUNTA QUEMADOR/INTERCAMBIADOR
24	R70050090	3	GUARNIZIONE VALVOLA VENTURI INGRESSO LAT	VENTURI GASKET	JOINT VENTURI	DICHTUNG	JUNTA VENTURI
25	R70060121	3	MANICOTTO RIDUZIONE De.45,5 Di.35 (PA 6)	REDUCTION COUPLING	MANCHON REDUCTION	REDUZIERMUFFE	MANGUITO REDUCCION
26	R65320010	2	SONDA LIVELLO TL 10/B	PROBE	PROBE	PROBE	PROBE
27	R77700056	3m	TUBO FLEX c/Spirale Di.30 De.35,3 COMAP	GAS INLET FLEXIBLE PIPE	TUBE FLEXIBLE ENTREE GAZ	FLEXROHR GASZULAUF	TUBO FLEXIBLE ENTRADA GAS
28	R63020170	3	VALVOLA GAS VK4115 V 1014 HON..	GAS SOLENOID VALVE	VALVE GAZ	GAS VENTIL	VALVULA GAS
29	R65060360	3	VENTILATORE RG128/1300-3612-020203	GAS BURNER FAN MOTOR	VENTILATEUR POUR BRULEUR GAZ	GEBLASEF.GASBRENNER	VENTILADOR PARA QUEMADOR GAS
30	R63120040	1	VENTURI VAL. GAS. BRUC. PREMIX45900444-002B	VENTURI TUBE	VENTURI	VENTURIROHR	VENTURI
31	R63120030	2	VENTURI VALV. GAS. BRUC. PRE-MIX45900446-053	VENTURI TUBE	VENTURI	VENTURIROHR	VENTURI
32	R62070023	3	BICONO PILOTA TUBO D.6 905.	BICONE D.6	BICONE D. 6	KEGEL D.6	BICONO D.6
33	R62060223	3	DADO PILOTA TUBO D.6 0903/1.	NUT D.6	ECROU D. 6	MUTTER D.6	DADO D.6

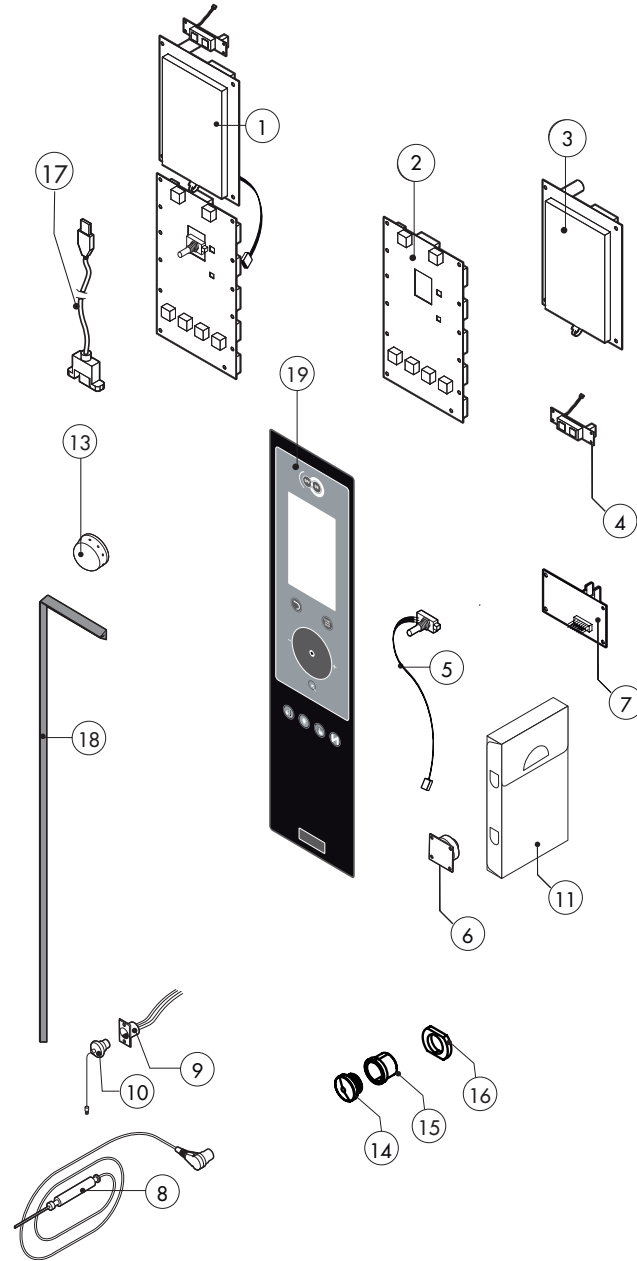





**ATTENZIONE:** PER TENSIONI SPECIALI, SPECIFICARE SEMPRE IL MODELLO DI FORNO ED IL NUMERO DI MATRICOLA  
**ATTENTION:** FOR SPECIAL VOLTAGES, PLEASE ALWAYS SPECIFY THE OVEN MODEL AND THE SERIAL NUMBER

**ATTENTION:** POUR TENSIONS SPÉCIALES, MERCI DE SPÉCIFIER TOUJOURS LE MODÈLE DU FOUR ET LE NUMÉRO DE SÉRIE  
**ACHTUNG:** BEI SONDRSPANNUNGEN, BITTE IMMER OFEN-MODELL UND SERIENNUMMER GEBEN.

ed. 0713

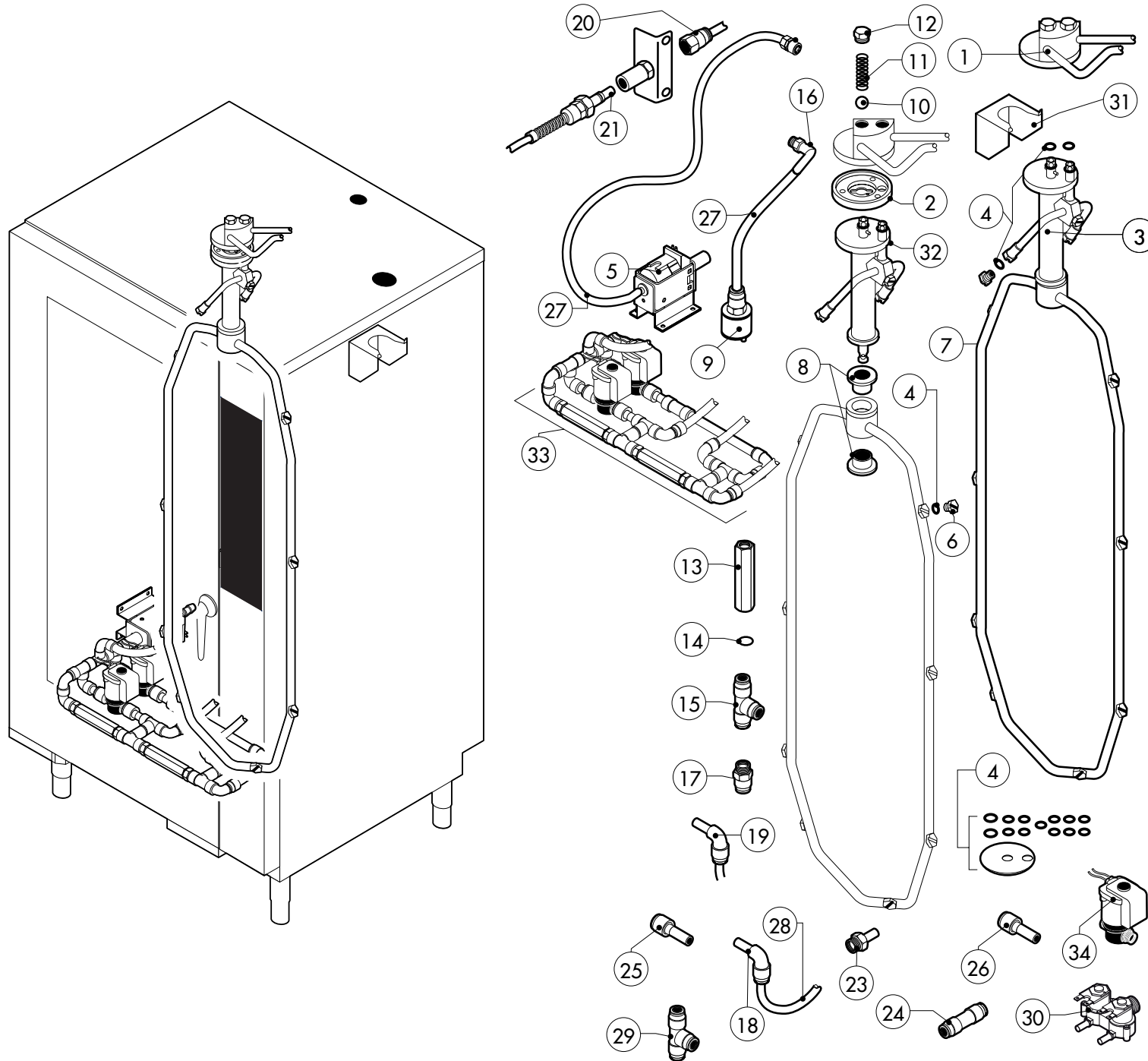

POS.	COD.	Pz.	DESCRIZIONE	DESCRIPTION	DESCRIPTION	BESCHREIBUNG	DESCRIPCIÓN
1	R11203340	1	ASS. BLOCCO ESTERNO LAVAGGIO CAM. K_201	WASHING SYSTEM EXTERNAL ASSEMBLY	ENSEMBLE EXTERIEUR DU LAVAGE	EXTERNE WASCHARMBEFESTIGUNG	BLOQUE EXTERNO LAVADO
2	R58004960	1	FLANGIA INTERNA LAVAGGIO	WASHING SYSTEM INNER FLANGE	BRIDE INTERIEUR BRAS DE LAVAGE	INNEN FLANSCH WASCHARMBEFESTIGUNG	PLATINA INTERNA LAVADO
3	R11100530	1	BRACCIO LAVAGGIO COMPLETO	WASHING DEVICE ASSEMBLY	BRAS DE RINCAGE COMPLET	WASHARM KOMPLETT	BRAZO LAVADO COMPLETO
4	R70045100	1	KIT GUARNIZIONI	GASKETS KIT	ENSEMBLE JOINTS	DICHTUNGSSATZ	KIT JUNTAS
5	R65110600	1	POMPA ELETTRON.A PIS.OSC.ET508.	DETRGENT PUMP	POMPE DETERGEANT	REINIGERPUMPE	BOMBA DETERGENTE
6	R62210032	8	UGELLO LAVAGGIO 1,3 L/MIN	1,3 L/MIN RINSING JET	GICLEUR LAVAGE 1,3 LITRE/MINUTE	SPULDUSE REINIGUNG 1,3L/MIN	INYECTOR LAVADO 1,3 L/MIN
7	R62210052	4	UGELLO OVK 110 $\phi$ 0,30 L/MIN 1,5BAR	0,30 L/MIN DETERGENT JET	GICLEUR DETERGENT 0,30 LITRE/MINUTE	SPULDUSE REINIGER 0,30 L/MIN	INYECTOR DETERGENTE 0,30 L/MIN
8	R58004980	2	BOCCOLA ROTAZIONE BRACCIO LAVAGGIO	WASHING DEVICE ROTATION BUSH	COQUILLE ROTATION BRAS LAVAGE	DEEHBUCHESE F. WASCHARM	CASQUILLO ROTACION BRAZO LAVADO
9	R65110650	1	VALVOLA DI FONDO PER FILTRO GM.060.35	BOTTOM FILTER	FILTER POUR TUBE DETERGEANT	ANSAUGFILTER F. REINIGUNGSSCHAUCH	VÁLVULA DE FONDO TUBO DEL LIMPIADOR
10	R62220012	2	SFERA D. 14	SPHERA D.14	SPHERE D. 14	VERSCHLUSSKUGEL D.14	ESFERA D.14
11	R61620041	2	MOLLA	SPRING	RESSORT	FEDER	MUELLE
12	R58005000	2	TAPPO MASCHIO 1/2"	1/2" MALE COVER	BOUCHON 1/2"	MUTTERSTOPFEN 1/2"	TAPON MACHO 1/2"
13	R65110680	2	VALVOLA ANTIRITORNO J.G. 10SCV	ANTI-BACK FLOW	ANTIRETOUR	RUCKFLUSSVERHINDERER	ANTIRETORNO
14	R70010050	4	GUARNIZIONE OR 7,60x2,62	JOINT OR 7,60x2,62	OR GASKETS	RINGDICHTUNG 7,60X2,62	VIDRIO OR 7,60x2,62
15	R62090468	5	RACCORDO INTERMEDIO A "T" D.10	T MIDLING PIPE FITTING D.10	RACCORD INTERMEDIAIRE A "T" D.10	MITTELVERBINDUNGSSTUCK D.10 "T"- FORMIG	RACOR INTERMEDIO TIPO "T" D.10
16	R62090678	2	RACC.A GOMITO C/CODOLO 8X8 PM220808E	ELBOW PIPE FITTING (WITH TANG) 8 X 8	COURBE AVEC QUEUE 8x8	WINKELVERBINDUNGSSTUCK 8X8 MIT SCHAFT	RACOR DE GOMA CON CODO 8x8
17	R62090688	1	RACC.TERMIN.DIR.FIL.CON.8X1/4 NC2500-P	8x1/4 STRAIGHT THREADED TERMINAL PIPE FITTING	RACCORD FILET DROIT 8x1/4"	ENDVERBINDUNGSSTUCK 8x1/4" GESCHNITTEN	RACOR TERMINAL DERECHO ROSCADO 8x1/4"
18	R62090528	6	RACCORDO A GOMITO CON CODOLO 10x10	ELBOW PIPE FITTING (WITH TANG) 10 X 10	COURBE AVEC QUEUE 10x10	WINKELVERBINDUNGSSTUCK 10 X 10 MIT SCHAFT	RACOR DE GOMA CON CODO 10x10
19	R62090808	2	GOMITO CON CODOLO $\phi$ 6- $\phi$ 6 PM220606E	8X1/8 END SIDE PIPE FITTING (WITH TANG)	RACCORD AVEC QUEUE 8x1/8"	ENDVERBINDUNGSSTUCK 8 X 1/8" MOT SCHAFT	RACOR TERMINAL CON CODO 8x1/8"
20	R62090538	1	RACCORDO DIRITTO FEMMINA 1/4" PER TUBO D.8x6	1/4" FEMALE STRAIGHT PIPE FITTING FOR D.6X8 PIPE	RACCORD DROIT PARTIE FEMELLE 1/4" TUBE 6x8	VERBINDUNGSSTUCK 1/4" WEBL. FUR ROHR D.6X8	RACOR DERECHO HEMBRA 1/4" PARA TUBO D.6x8
21	R62090482	1	RACCORDO RAPIDO MASCHIO	RAPID MALE PIPE FITTING	RACCORD RAPIDE PARTIE MALE	SCHNELLEVERBINDUNG MANNL	RACOR RAPIDO MACHO
22	R62090638	1	RACC.RAP.FEMM.X LAV.FIL.FEMM PVPU40-F1/4	RAPID FEMALE PIPE FITTING	RACCORD RAPIDE PARTIE FEMELLE	SCHNELLEVERBINDUNG	RACOR RAPIDO HEMBRA
23	R62090608	2	RACCORDO TERMINALE C/CODOLO 8x1/8"	8X1/8 END SIDE PIPE FITTING (WITH TANG)	RACCORD AVEC QUEUE 8x1/8"	ENDVERBINDUNGSSTUCK 8 X 1/8" MOT SCHAFT	RACOR TERMINAL CON CODO 8x1/8"
24	R62090458	1	RACCORDO INTERMEDIO DRITTO D.10	PIPE FITTING	COURBE	STUCK	RACOR
25	R62090618	2	RACCORDO DIRITTO RIDUZIONE 10-8	REDUCTION PIPE FITTING	RACCORD DROIT REDUCTION	GERADE ANSCHLUSS-VERKLEINERUNG	RACOR DERECHO REDUCCION
26	R62090548	4	RACCORDO DIRITTO RIDUZIONE 10-6	REDUCTION PIPE FITTING	RACCORD DROIT REDUCTION	GERADE ANSCHLUSS-VERKLEINERUNG	RACOR DERECHO REDUCCION
27	R80150020	2	TUBO PE D.8mm x 6	PIPE	TUBE	LEITUNG	TUBO
28	R80150030	1	TUBO PE D.10mm x 7 (3 MT.)	PIPE	TUBE	LEITUNG	TUBO
29	R62090488	1	RACCORDO INTERMEDIO A "T" D.6 PM0206E	T MIDLING PIPE FITTING	RACCORD INTERMEDIAIRE A "T"	MITTELVERBINDUNGSSTUCK "T"- FORMIG	RACOR INTERMEDIO TIPO "T"
30	R65110210	1	ELETTR. 2 VIE 220V 50HZ X J.G..	SOLENOID VALVE 220V 50HZ WITH FLOW REDUCER	ELECTROVANNE 220V 50HZ AVEC REG.DE DEBIT	MAGNETVENTIL 220V 50HZ MIT DRUCKMINDERER	ELECTROVALVULA DOBLE 220V 50HZ C/ REDUCT.
31	R11402000	1	SUPPORTO ESTERNO BRACCIO LAVAGGIO	WASHING DEVICE EXTERNAL HOLDER	SUPPORT EXTERIEUR BRAS DE LAVAGE	WANDHALTERUNG FUR WASHARM	SOPORTE EXTERNO BRAZO LAVADO
32	R14102550	1	TUBO SUPPORTO BRACCIO LAVAGGIO T06-M/072	TUBE DEVICE SUPPORT WASHING	TUBE JE SUPPORTE DISPOSITIF LAVAGE	HALTERUNGSROHRWASCHRAUM	TUBO SUPORTE BRAZO LAVADO
33	R62300058	1	GRUPPO ANTIRIT.+SVUOT. COND.K_102-072-201	ANTI-BACK FLOW DEVICE ASSEMBLY	GROUPE JE COMPLÉTE ANTI-RETOUR	KOMPLET RÜCKFLUSSVENTIL SATZ	KIT ANTIRETORNO COMPLETO
34	R65110260	2	ELETTROV.SR.7 NA JOHN GUEST D.6 230V50HZ	SOLENOID VALVE D.6 230V 50HZ	ELECTROVANNE D.6 230V 50HZ	MAGNETVENTIL D.6 230V 50HZ	ELECTROVALVULA D.6 230V 50HZ
35	R70070080	1	TUBO GOMMA PER ALIMENTI Di13 De23 L=1MT	PIPE	TUBE	LEITUNG	TUBO