

ATTENZIONE: PER TENSIONI SPECIALI, SPECIFICARE SEMPRE IL MODELLO DI FORNO ED IL NUMERO DI MATRICOLA
ATTENTION: FOR SPECIAL VOLTAGES, PLEASE ALWAYS SPECIFY THE OVEN MODEL AND THE SERIAL NUMBER

ATTENTION: POUR TENSIONS SPÉCIALES, MERCI DE SPÉCIFIER TOUJOURS LE MODÈLE DU FOUR ET LE NUMÉRO DE SÉRIE
ACHTUNG: BEI SONDRSPANNUNGEN, BITTE IMMER OFEN-MODELL UND SERIENNUMMER GEBEN.

ed. 0713

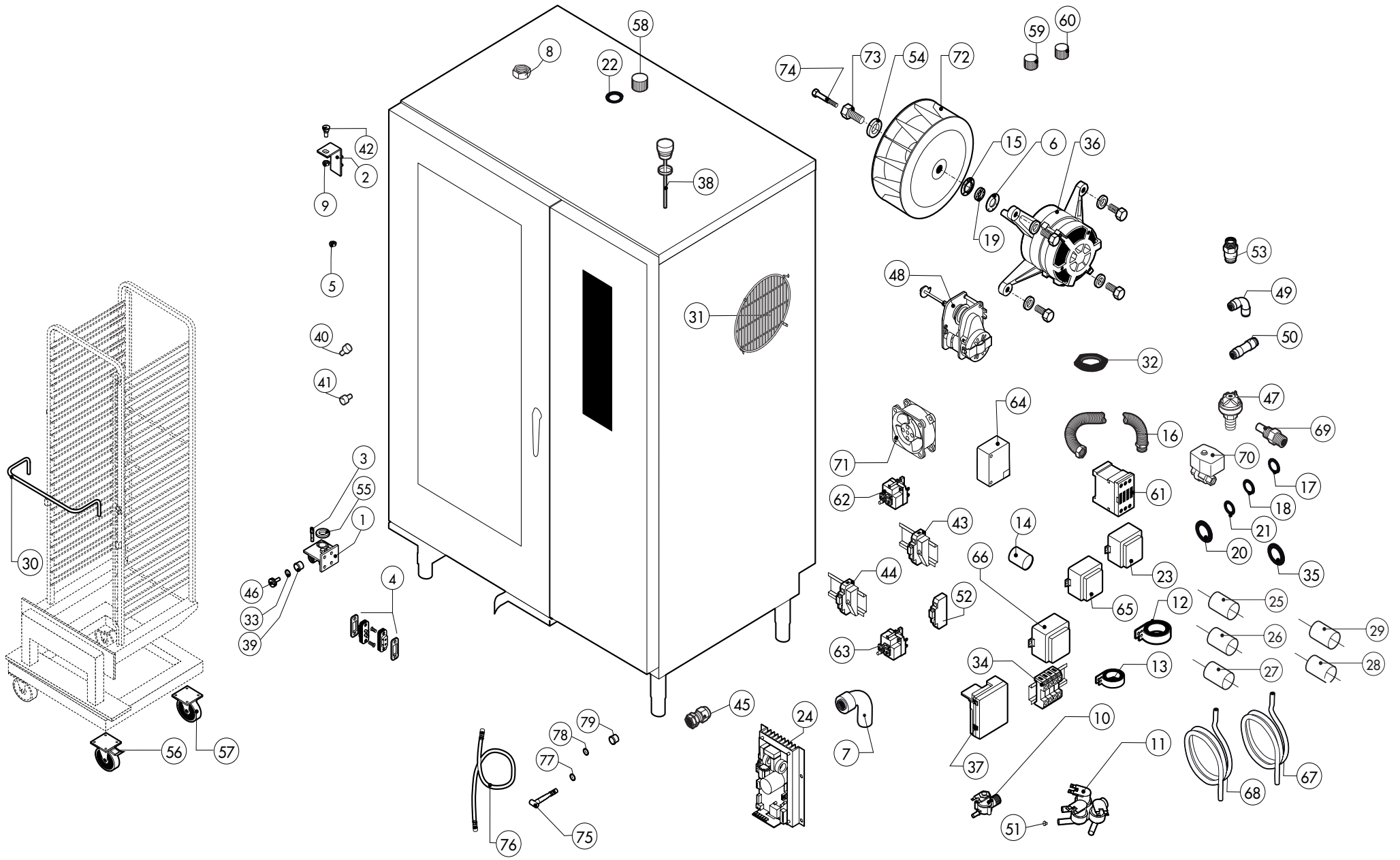

ATTENZIONE: PER ORDINARE I RICAMBI, SPECIFICARE SEMPRE IL MODELLO DI FORNO ED IL NUMERO DI MATRICOLA
ATTENTION: WHEN ORDERING SPARE PARTS, PLEASE ALWAYS SPECIFY THE OVEN MODEL AND THE SERIAL NUMBER

ATTENTION: POUR COMMANDER DES PIÈCES, MERCI DE SPECIFIER TOUJOURS LE MODÈLE DU FOUR ET LE NUMÉRO DE SÉRIE
ACHTUNG: UM ERSATZTEILE ZU BESTELLEN, BITTE IMMER OFEN-MODELL UND SERIENNUMMER GEBEN.

ed. 0713

POS.	COD.	Pz.	DESCRIZIONE	DESCRIPTION	DESCRIPTION	BESCHREIBUNG	DESCRIPCIÓN
1	R11205390	1	ASS.CERNIERA INFERIORE M-V/201-202	LOWER DOOR HINGE	CHARNIERE INFERIEURE PORTE	UNTERES SCHARNIER	BISAGRA INFERIOR
2	R11426830	1	CERNIERA SUPER.PORTA SR.2013	UPPER DOOR HINGE	CHARNIERE SUPERIEURE PORTE	OBERES SCHARNIER	BISAGRA SUPERIOR
3	R58002540	1	CHIAVETTA X PERNO C/FERMO PORTM-V/120-22	DOOR PIVOT SUNK KEY	CLAVETTE POUR CHEVILLE PORTE	KEIL F. TUERSTIFT	LLAVE PARA PERNO PUERTA
4	R65260752	1	CONTATTO PER LUCI SR.2014+FORNI A PAVIM.	LAMPS CONTACT BLOCK	CONTACT ECLAIRAGE	LICHTKONTSCHALTER	CONTACTO PARA LUZ
5	R65240020	1	CONTRODADO PG 116/16/NY	CABLE GLAND LOCK NUT	CONTRE-ECROU POUR RONDELLE FIXATION	MUTTER	CONTRODADO PASACABLE
6	R58003850	2	CONTROFLANGIA GUARN.GRANDE	MOTOR GASKET BRASS COUNTER FLANGE	CONTRE- BRIDE JOINT MOTEUR	GEGENFLANSCH F. MOTORDICHTUNG	CONTRABRIDA JUNTA MOTOR
7	R62280038	1	CURVA C/MORSET.HTS-HTSW X TUBO D.50 D.50X	CURVE WITH TERMINAL	COURBE AVEC BORNIER	KURVE MIT KLEMM	CURVA CON REGLETERA
8	R58006900	2	DADO INOX 1"1/2	NUT	ECROU	MUTTER	TUERCA
9	R58004050	1	DADO PER PERNO CERNIERA REG. M/106-220	NUT FOR UPPER DOOR HINGE	ECROU CHEVILLE CHARNIERE SUPERIEURE	MUTTER F. OBERES SCHARNIERSTIFT	TUERCA PARA PERNO BISAGRA SUPERIOR
10	R65110200	1	E.V. 1 VIA 220V 50HZ X J.G.CON ATTACC	SOLENOID VALVE	ELECTROVANNE	MAGNETVENTIL	ELECTROVALVULA
11	R65110280	1	E.V. 3 VIE 220V 50HZ X J.G.CON ATTACC	SOLENOID VALVE 220V 50HZ	ELECTROVANNE 220V 50HZ	MAGNETVENTIL 220V 50HZ	ELECTROVALVULA 220V 50HZ
12	R65280490	1	FERRITE TOROIDALE FT36	FERRITE FT36	FERRITE FT36	FERRIT FT36	FERRITA FT36
13	R65280480	2	FERRITE TOROIDALE FT25	FERRITE FT25	FERRITE FT25	FERRIT FT25	FERRITA FT25
14	R65280240	1	FILTRO FLC470501F	INTERFERENCE SUPPRESSOR	FILTRE ANTIPARASITES	STOERSCHUTZFILTER	FILTRO
15	R58003840	2	FLANGIA GUARN.GRANDE	MOTOR GASKET BRASS FLANGE	BRIDE JOINT MOTEUR	FLANSCH F. MOTORDICHTUNG	BRIDA JUNTA MOTOR
16	R62180182	1	FLEX H2O L=10-20CM M/F1" INOX DADO OT.	FLEXIBLE PIPE	TUBE FLEXIBLE	FLEXROHR	TUBO FLEXIBLE
17	R70010030	1	GUARNIZIONE OR 6,07 X 1,78 SILICONE	OR GASKETS 6,07 X 1,78	JOINT 6,07 X 1,78	RINGDICHTUNG 6,07 X 1,78	VIDRIO OR 6,07 X 1,78
18	R70030060	1	GUARNIZIONE D. 22X30 1"	GASKET	JOINT	DICHTUNG	JUNTA
19	R70020050	2	GUARNIZIONE MARK IV MLA 2400.02.05	GASKET	JOINT	DICHTUNG	JUNTA
20	R70010210	1	GUARNIZIONE OR NBR 70 18,72x2,62 C.3075	GASKET	JOINT	DICHTUNG	JUNTA
21	R65070230	1	GUARNIZIONE PER TERM.SIC.CA-MERM/106-110	GASKET	JOINT	RINGDICHTUNG	JUNTA
22	R70050140	1	GUARNIZIONE X TAPPO BOYLER PLAST. G40015	GASKET	JOINT	RINGDICHTUNG	JUNTA
23	R65450200	2	INDUTTANZA 6,5 mH 8A	INDUCTANCE	INDUCTANCE	INDUKTANZ	INDUCTANCIA
24	R65140890	2	INVERTER 0.5KW MOT. INF. A001M005XSB X RIC	INVERTER	INVERSEUR	INVERTER	INVERSOR
25	R62090713	1	MANICOTTO FF 3/4"-1/2" OT	COUPLING	MANCHON	MUFFE	FUNDA
26	R70060080	1	MANICOTTO SILICONE D.13X18X80	SILICON SLEEVE	SILICONE SLEEVE	SILIKONHÜLLE	FUNDA DE SILICONA
27	R70060020	1	MANICOTTO SILICONE D.30X35X9 TAPPO SFIA	SILICON SLEEVE	SILICONE SLEEVE	SILIKONHÜLLE	FUNDA DE SILICONA
28	R70060040	2	MANICOTTO SILICONE D.50X50X3	SILICON SLEEVE	SILICONE SLEEVE	SILIKONHÜLLE	FUNDA DE SILICONA
29	R70060050	1	MANICOTTO SILICONE D.60	SILICON SLEEVE	SILICONE SLEEVE	SILIKONHÜLLE	FUNDA DE SILICONA
30	R10457840	1	MANIGLIA CARRELLO KS/021-040	HANDLE FOR TROLLY	POIGNÉE POUR CHARIOT PORTE POELES	HANDGRIFF-LAUFKATZE	MANIJA CARRO PORTABANDEJAS
31	R75300090	2	MASCHERINA VENTILATORE D.350	FAN GUARD GRID D.120	GRILLE VENTILATEUR D.120	VENTILATORSCHUTZGITTER D.120	REJILLA VENTILADOR D.120
32	R70010120	1	GUARNIZIONE SILICONE ROSSO 90X90X3	RED GASKET	JOINT ROUGE	ROTEN DICHTUNG	JUNTA ROJA
33	R61620091	16	MOLLA A TAZZA D.14/6,4X0,8 C70.	BELLEVILLE WASHER Ø 14/6.4	RESSORT A DISQUE Ø 14/6.4	TELLERFEDER Ø 14/6.4	MUELLE A DISCO Ø 14/6.4
34	R65220280	1	MORSETTIERA MONOFASE C/TERRA PAS-SANTE	TERMINAL BOARD	BORNIER	KLEMMLEISTE	REGLETERA
35	R70045010	1	GUARNIZIONE NERA RESISTENZA BOILER	GASKET	JOINT	DICHTUNG	JUNTA
36	R65040530	2	MOTORE KW 055 F3 4P 3039 200-440V I	MOTOR	MOTEUR	MOTOR	MOTOR
37	R63060160	4	PANNELLO ACCENS. S4565C1116B Ts=5 Tps=1	BURNER IGNITION PANEL	ALLUMEUR GAZ	ZUENDBOX	PANEL DE ENCENDIDO
38	R10100140	1	TAPPO SFIATO COMPLETO M/106-. -220	COVER	BOUCHON	ABDECKUNG	TAPON
39	R58002550	1	PATTINO FERMO PORTA M-V/120- 220	DOOR RETAINER GUIDE SHOE	PATIN ARRET PORTE	GLEITSTUECK F. TUERARRETIERUNG	PATILLA CIERRE PUERTA
40	R58003140	3	PERNO AGGANCIO DEFLETTORE	FAN GUARD PANEL PIN	PIVOT DEFLECTEUR	BOLZEN FÜR LUFTLEITBLECH	PERNO CIERRE DEFLECTOR

TAV. A

KMG 202 X

ATTENZIONE: PER ORDINARE I RICAMBI, SPECIFICARE SEMPRE IL MODELLO DI FORNO ED IL NUMERO DI MATRICOLA
ATTENTION: WHEN ORDERING SPARE PARTS, PLEASE ALWAYS SPECIFY THE OVEN MODEL AND THE SERIAL NUMBER

ATTENTION: POUR COMMANDER DES PIECES, MERCI DE SPECIFIER TOUJOURS LE MODELE DU FOUR ET LE NUMERO DE SERIE
ACHTUNG: UM ERSATZTEILE ZU BESTELLEN, BITTE IMMER OFEN-MODELL UND SERIENNUMMER GEBEN.

ed. 0713

POS.	COD.	Pz.	DESCRIZIONE	DESCRIPTION	DESCRIPTION	BESCHREIBUNG	DESCRIPCIÓN
41	R58003110	3	PERNO FISSAGGIO DEFLETTORE	FAN GUARD PANEL PIN	PIVOT DEFLECTEUR	BOLZEN FÜR LUFTLEITBLECH	PERNO CIERRE DEFLECTOR
42	R58002150	1	PERNO SUP. CERNIERA REG. M/106-220	UPPER HINGE PIN	CHEVILLE CHARNIERE SUPERIEURE	OBERES SCHARNIERSTIFT	PERNO SUPERIOR BISAGRA
43	R65210020	8	PORTAFUSIBILE BARRA DIN 5x20	FUSE CARRIER	PORTE-FUSIBLE	SICHERUNGSHALTER	PORTAFUSIBILE
44	R65210050	2	PORTAFUSIBILE BARRA DIN 6,3x32	FUSE CARRIER	PORTE-FUSIBLE	SICHERUNGSHALTER	PORTAFUSIBILE
45	R65240010	1	PRESSACAVO PG 107 Z/16	FAIRLEAD	PRESSE CABLE	ZUGENTLASTUNG	PRENSACABLES
46	R58002560	1	PRESSORE FERMO PORTA M-V/120- 220	SCREW FOR LOWER DOOR HINGE	VIS POUR CHARNIERE INFERIEURE	DRUCKSCHRAUBE F. UNTERERS TUERSCHARNIER	TORNILLO PARA BISAGRA INFERIOR
47	R63070010	1	PRESSOSTATO PG 901.61	GAS SAFETY PRESSURE SWITCH	INT.A PRESSION SECURITE-GAZ	DRUCKSCHALTER PG	PRESOSTATO GAS
48	R65090220	1	PROGRAMMAT. 1 CAMME V220/50HZ 1 CIRCUITO	DAMPER SYSTEM	SORTIE EVAPORATION MOUFLE	DAMPFABLASS-STELLMOTOR	MOTOR RESPIRADERO COMPLETO
49	R62090478	1	RACC. INTERMEDIO A GOMITO D.10 PM0310E	ELBOW PIPE FITTING	COURBE AVEC QUEUE	STUCK MIT SCHAFT	RACOR CON CODO
50	R62090458	2	RACC. INTERMEDIO DIRITTO D.10 PM0410E	PIPE FITTING	COURBE	STUCK	RACOR
51	R65110510	2	REGOL. PORTATA ROSSO ALPHATECH1.5LT/H	1.5 LT/H WATER FLOW REDUCER	REGULATUER DE DEBIT 1.5 LT.	DURCHFLOSSMONDERER 1.5 L/STD.	REGULADOR DE CAUDAL 1.5 LT.
52	R65170190	1	RELE' FINDER 40R.31.8.230.5000 1 CO.SCAM.	RELAY	RELAIS	RELAIS	RELE
53	R62090723	1	RIDUZIONE MF 1/2"-1/4" OT	REDUCTION	REDUCTION	VERRINGERUNG	REDUCCION
54	R58004010	2	ROND.FISS.VENTOLA D 30/12.5	FAN WASHER Ø 30/12.5	RONDELLE TURBINE Ø 30/12.5	UNTERLEGSCHLEIBE Ø 30/12.5	ARANDELA FIJACION TURBINA Ø 30/12.5
55	R58002570	1	RONDELLA 30/15X3 M-V/120-220	WASHER Ø 30/15X3 M-V/120-220	RONDELLE Ø 30/15X3 M-V/120-220	UNTERLEGSCHLEIBE Ø 30/15X3 M-V/120-220	ARANDELA Ø 30/15X3 M-V/120-220
56	R69090360	2	RUOTA GIR.DOPPIA C/FR. D.100 (5945UAP100)	WHEEL	ROUE	RAD	RUEDA
57	R69090350	2	RUOTA GIR.DOPPIA D.100 (5940UAP100)	WHEEL	ROUE	RAD	RUEDA
58	R69150110	1	TAPPO FEMMINA G 1"1/4 PP+25%FV NERO	COVER	BOUCHON	ABDECKUNG	TAPON
59	R62100108	1	TAPPO ROSSO D.10 (PM0810R)	COVER D.10	BOUCHON D.10	ABDECKUNG D.10	TAPON D.10
60	R58005070	1	TAPPO TANICA VERDE x CALOUT	COVER FOR CALOUT	BOUCHON POUR CALOUT	ABDECKUNG FÜR CALOUT	TAPON POR CALOUT
61	R65140380	1	TELERUTTORE 3RT1016-1AP02	CONTACTOR	CONTACTEUR	SCHUETZ	CONTACTOR
62	R65070350	1	TERMOSTATO SICUR. 360°C -25K 55.32572.8	THERMOSTAT	THERMOSTAT	THERMOSTAT	TERMOSTATO
63	R65070081	1	TERMOSTATO SICUR. BOILER M/1065532522852	THERMOSTAT	THERMOSTAT	THERMOSTAT	TERMOSTATO
64	R65180270	4	TRASF.ACCENS. COFI TRK2-3PVD	IGNITION TRANSFORMER	TRANSFORMATEUR D'ALLUMAGE	ZÜNDTRANSFORMATOR	TRANSFORMADOR DE ENCENDIDO DESDE
65	R65180420	2	TRASF.RE 20VA 0-220-240/12V MOD.163.16	TRANSFORMER 20VA	TRANSFORMATEUR 20VA	TRANSFORMATOR 20VA	TRANSFORMADOR 20VA
66	R65180430	1	TRASF.RE 40VA 0-220-240/12V MOD.163.82	TRANSFORMER 40VA	TRANSFORMATEUR 40VA	TRANSFORMATOR 40VA	TRANSFORMADOR 40VA
67	R80150000	4	TUBO PE 10MMX7 AZZURRO PM950612E	BLUE PIPE	TUBE	LEITUNG	TUBO
68	R80120060	5	TUBO SILIC. TRASP.SR60/TR 7/12.	PIPE	TUBE	LEITUNG	TUBO
69	R58006160	2	UGELLO COND.D.0,8 CODOLO CIL.10	NOZZLE	BEC	DÜSE	BOQUILLA
70	R65110570	1	VALVOLA A SFERA MOTORIZZATA 2VIE 230V 1"	STEAM GENERATOR DRAIN MOTORIZED VALVE	DRAINAGE CHAUDIERE	BOILERABLAUFVENTIL	VALVULA DE BOLA MOTORIZADA
71	R65060050	4	VENTILATORE COMPATTO D.120 4715MS 23T	COMPONENTS VENTILATION MOTOR	MOTEUR DE REFRROIDISSMENT	ABKÜLUNGS MOTOR	MOTOR DE ENFRIAMIENTO
72	R75400440	2	VENTOLA D.350X114/12 50HZ P.D.	FAN	TURBINE	LUEFTERRAD	PALA VENTILADOR
73	R58004000	2	VITE FISS.VENTOLA M/12X1.5 SX	FAN SCREW M12x1.5 SX	VIS DE BLOCAGE TURBINE M12x1.5 SX	VENTILATORSCHRAUBE M12x1.5 SX	TORNILLO FIJACION TURBINA M12x1.5 SX
74	R61020562	2	VITE TE A2 M 6X55 UNI 5737	MOTOR SCREW TE A2 M6x55	VIS DE BLOCAGE MOTEUR TE A2 M6x55	MOTORSCHRAUBE TE A2 M6x55	TORNILLO MOTOR TE A2 M6x55
75	R62200028	1	LANCIA DI LAVAGGIO SENZA TUBO	SHOWER HANDLE	POIGNEE DOUCHETTE	GRIFF F. HANDBRAUSE	MANGO DUCHA
76	R62200058	1	GOMMA 1/2"X1/2"X2.5M LANCIA L.2500 MM	FLEXIBLE PIPE SHOWER	TUBE FLEXIBLE DOUCHETTE	SCHEAUCH FUER HANDBRAUSE	TUBO FLEXIBLE DUCHA
77	R70030040	2	GUARNIZIONE D.16X24 3/4 GOMMA	GASKET D.16X24 3/4	JOINT D.16X24 3/4	DICHTUNG D.16X24 3/4	JUNTA D.16X24 3/4
78	R70030030	1	GUARNIZIONE D. 11X19 1/2"	GASKET D. 11X19 1/2"	JOINT D. 11X19 1/2"	DICHTUNG D. 11X19 1/2"	JUNTA D. 11X19 1/2"
79	R69180300	1	SUPPORTO IN PLASTICA X DOCCIONE ESTERNO	HOLDER	SUPPORT	GESTELL	SOPORTE

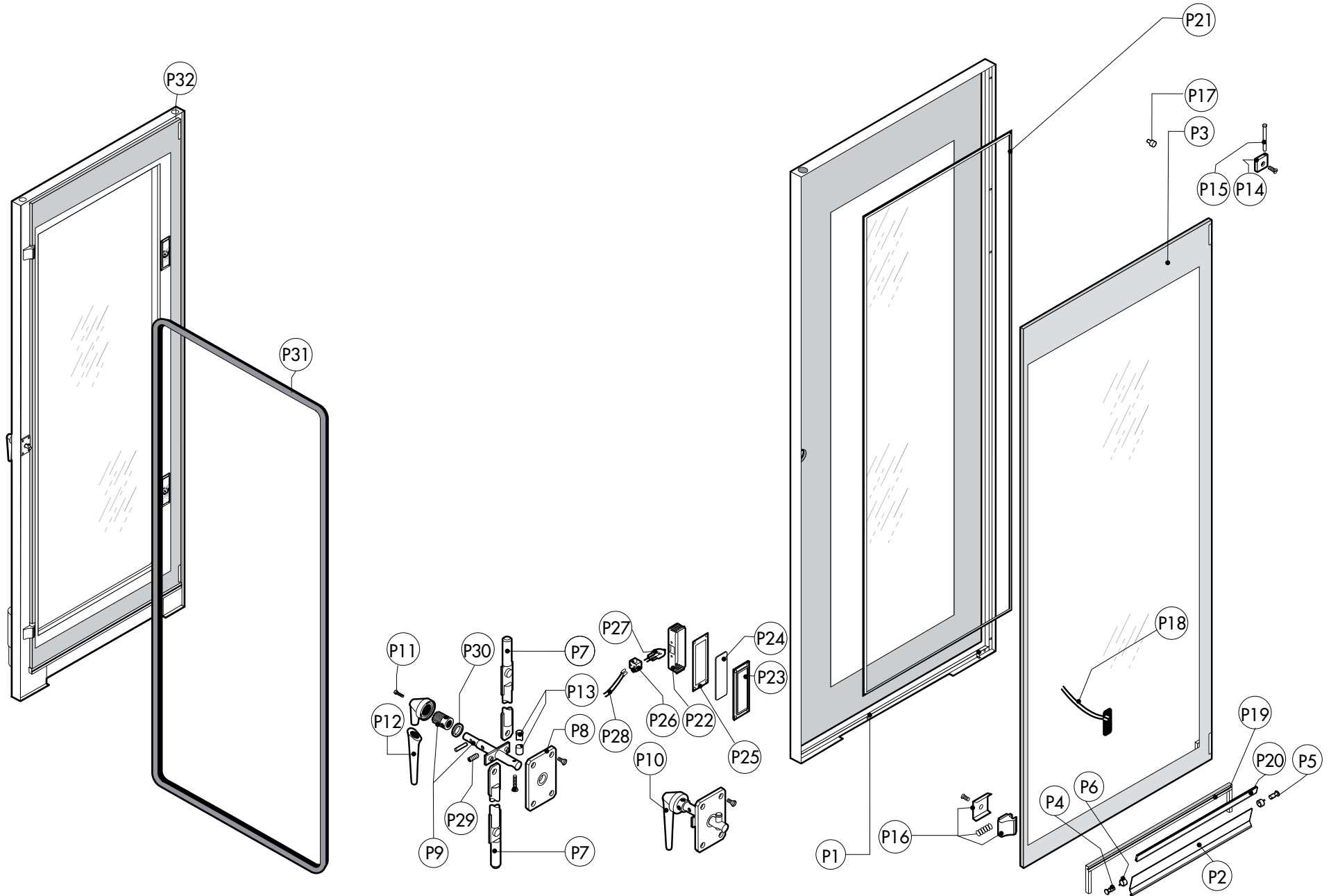

POS.	COD.	Pz.	DESCRIZIONE	DESCRIPTION	DESCRIPTION	BESCHREIBUNG	DESCRIPCIÓN
P1	R11214060	1	PORTA ESTERNA K_202	EXTERNAL DOOR	PORTE D'EXTERNAL	AUSSENTÜR	PUERTA EXTERNA
P2	R11437930	1	BANDELLA DI TAMPONAMENTO K_202	CLOSING PLATE	TÔLE DE FERMETURE	VERSCHLUBLEISTE	PLACA DE CIERRE
P3	R71201870	1	VETRO INTERNO PORTA K_201-202	INNER DOOR GLASS	VERRE INTERIEUR PORTE	INNERES TÜRGLAS	VIDRIO INTERNO PUERTA
P4	R58006861	2	FULCRO X BANDELLA INS. MOLLA	CLOSING PLATE RORAZIONE PIVOT	AXE ROTATION TÔLE DE FERMETURE	DREH	PIVOTE DE CIERRE DE LA PLACA RORAZIONE
P5	R58006910	2	FULCRO FISSAGGIO BANDELLA	PIVOT	AXE	DREHBOLZEN F.VERSCHLUBLEISTE	PIVOTE
P6	R65491250	1	KIT MOLLE BANDELLA TAMPONAMENTO	CLOSING PLATE SPRING ASSEMBLY	KIT RESSORTS TÔLE DE FERMETURE	FEDERSATZ F.VERSCHLUBLEISTE	KIT RESORTE DE PLACA DE CIERRE
P7	R11207670	2	ASS.ASTINA AZ. PUNTONI K_201-202	ROD	CREMAILLÈRE	VERSCHLUSSTANGE	EJE
P8	R03200970	1	ASS.FLANGIA BOCCOLA POST.	DOOR LOCK REAR FLANGE	FLASQUE POSTERIEUR PORTE	FLANSCH	BRIDA SOPORTE POSTERIOR
P9	R11205340	1	ASS.PERNO MANIGLIA M-V/201-202	DOOR HANDLE PIN	AXE MANOEUVRE	SCHLIESSNASE AM TÜRGRIF	PERNO MANETA
P10	R11100311	1	GRUPPO CHIUSURA COMPLETA K_201-202	DOOR CATCH KIT	ENSAMBLE FERMETURE PORTE	VERSCHLUSSSATZ	MANIJA DE LA PUERTA
P11	R69010740	1	TAPPO MAN. BLU GR.6303 C/ANELLO CROM.	DOOR HANDLE	POIGNEE DE PORTE	GRIFFKORPUS	CUERPO MANETA
P12	R69010810	1	MANIGLIA BLU GR.6303 VERS.2011	HANDLE	POIGNEE	TÜRGRIF	MANGO MANETA
P13	R58004781	1	GANCIO PERNO MANIGLIA C/NOTT. M/120-220	DOOR HANDLE HOOK	DECLIC AXE MANOEUVRE	HAKEN F. TÜRGRIF	GANCHO PERNO MANETA
P14	R58001760	2	CERNIERA FISSA VETRO SR2000	HINGE	CHARNIÈRE	SCHARNIER	BISAGRA
P15	R58001770	2	PERNO CERNIERA VETRO SR2000	INNER GLASS HINGE PIN	PIVOT CHARNIÈRE VERRE INTERIEUR	SCHARNIERBOLZEN F. INNENSCHIEBE	PERNO BISAGRA VIDRIO INTERNO
P16	R58001780	2	FERMO VETRO PORTA P2000	INNER GLASS CATCH KIT	ENSEMBLE ARRET VERRE INTERIEUR	VERSCHLUSSSATZ F. INNENSCHIEBE	KIT FIJACION VIDRIO INTERNO
P17	R70050180	9	DISTANZIALE VETRO 15x8 SIL.55SH M4x12 A2	THICKNESS	EPAISSEUR	DICKE	ESPEJOR
P18	R65265100	1	MICRO PORTA MAGNETICO COMPLETORIC.	DOOR SWITCH	MICRO PORTE	TUERSCHALTER	MICRO PUERTA
P19	R70044362	1	GUARNIZIONE BATTUTA CAR.C/TAMP.K_202	GASKET	JOINT	DICHTUNG	JUNTA
P20	R80100910	0,4	PROFILO GUARNIZIONE BANDELLA	CLOSING PLATE GASKET	JOINT TÔLE DE FERMETURE	DICHTUNG F.VERSCHLUBLEISTE	JUNTA PARA PLACA DE CIERRE
P21	R80100100	3,58	PROFILO GUARN.2 CRISTALLI	GASKET	JOINT	DICHTUNG	JUNTA
P22	R11401440	2	CALOTTA LAMPADA SR.2000	LAMP COVER	CALOTTE DE PROJECTEUR	LAMPENKALOTTE	CUBIERTA LAMPARA
P23	R11401450	2	FLANG.STAMP.VETRO LAMP. SR2000.	GLASS HOLDER LAMP FLANGE	BRIDE ARRET-VERRE ECLAIRAGE	FLANSH F.LAMPENVERGLASUNG	TAPA CRISTAL LAMPARA
P24	R71500150	2	VETRO LAMPADA P2000	GLASS LAMP	VERRE PROTECTION LAMPE	LAMPEGLAS	VIDRIO LAMPARA
P25	R70044200	2	GUARNIZIONE VETRO LAMPADA P2000	LAMP GASKET	JOINT VERRE ECLAIRAGE	LAMPENDICHTUNG	VIDRIO CUBRELAMPARA
P26	R65270450	2	PORTAL. STUCCHI ART.216	LIGHT SOCKET	DOUILLE	LICHTKONTSCHALTER	PORTALAMPARA PARA LAMPARA HALOGENA
P27	R65270020	2	LAMPADA ALOGENA 20W 12V G4 49040	LIGHT 20W 12V G4	LAMPE 20W 12V G4	LAMPENHALTERUNG	LAMPARA HALOGENA 20W 12V G4
P28	R66110330	1	CABLAGGIO LUCI PORTA M-V/201-202	DOOR LAMPS CABLE SET	CABLES ECLAIRAGE PORTE	VERDRAHTUNG TURBELEUCHTUNG	CABLEADO LUCES PUERTA
P29	R61090052	1	VITE STEI M6x16	GRUB SCREW M6x16	VIS SANS TÊTE M6x16	SENKKOPFSCHRAUBE M6x16	TORNILLO SIN CABEZA M6X16
P30	R61600031	2	ANELLO ELASTICO RADIALE D.3,2 UNI 7434	ELASTIC RING	ANNEAU ÉLASTIQUE	ELASTISCHER RING	ANILLO ELASTICO
P31	R70044920	1	TELAIO GUARN. PORTA K_202	FRONT GASKET	JOINT FACADE	DICHTUNG DER FRONTSEITE	JUNTA FRONTAL
P32	R11103710	1	PORTA COMPLETA K_202	DOOR ASSEMBLY	PORTE COMPLETE	TÜR KOMPLETT	PUERTA COMPLETA

ATTENZIONE: PER TENSIONI SPECIALI, SPECIFICARE SEMPRE IL MODELLO DI FORNO ED IL NUMERO DI MATRICOLA
ATTENTION: FOR SPECIAL VOLTAGES, PLEASE ALWAYS SPECIFY THE OVEN MODEL AND THE SERIAL NUMBER

ATTENTION: POUR TENSIONS SPÉCIALES, MERCI DE SPÉCIFIER TOUJOURS LE MODÈLE DU FOUR ET LE NUMÉRO DE SÉRIE
ACHTUNG: BEI SONDRERSPANNUNGEN, BITTE IMMER OFEN-MODELL UND SERIENNUMMER GEBEN.

ed. 0713

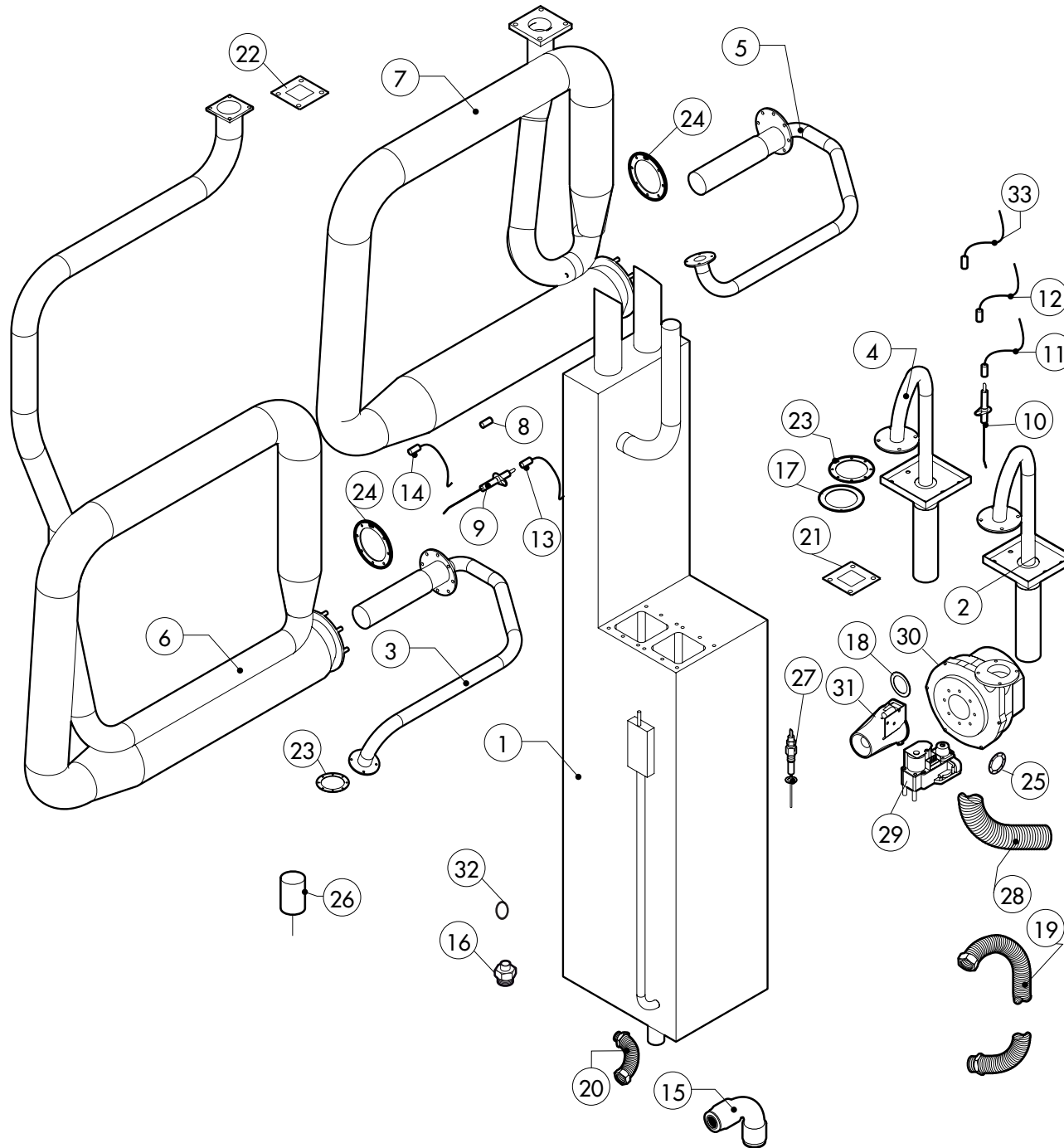

ATTENZIONE: PER ORDINARE I RICAMBI, SPECIFICARE SEMPRE IL MODELLO DI FORNO ED IL NUMERO DI MATRICOLA
ATTENTION: WHEN ORDERING SPARE PARTS, PLEASE ALWAYS SPECIFY THE OVEN MODEL AND THE SERIAL NUMBER

ATTENTION: POUR COMMANDER DES PIÈCES, MERCI DE SPECIFIER TOUJOURS LE MODÈLE DU FOUR ET LE NUMÉRO DE SÉRIE
ACHTUNG: UM ERSATZTEILE ZU BESTELLEN, BITTE IMMER OFEN-MODELL UND SERIENNUMMER GEBEN.

ed. 0713

POS.	COD.	Pz.	DESCRIZIONE	DESCRIPTION	DESCRIPTION	BESCHREIBUNG	DESCRIPCIÓN
1	R11214170	1	ASS.BOILER C/CAL-OUT KMG202	STEAM GENERATOR ASSEMBLY	CHAUDIERE COMPLETE	DAMPFERZEUGER KOMPLETT	BOILER COMPLETO
2	R11224182	1	ASS.BRUCIATORE EST. BOILER HMG202	COOKING CABINET BURNER	BRÛLEUR MOUFLE	BOILERBRENNER	QUEMADOR CALDERA
3	R11224162	1	ASS.BRUCIATORE INF. CAMERA HMG202	COOKING CABINET BURNER	BRÛLEUR MOUFLE	GARRAUMBRENNER	QUEMADOR CAMERA
4	R11224172	1	ASS.BRUCIATORE INT. BOILER HMG202	COOKING CABINET BURNER	BRÛLEUR MOUFLE	BOILERBRENNER	QUEMADOR CALDERA
5	R11224152	1	ASS.BRUCIATORE SUP. CAMERA HMG202	COOKING CABINET BURNER	BRÛLEUR MOUFLE	GARRAUMBRENNER	QUEMADOR CAMERA
6	R11224060	1	ASS.SCAMBIATORE. CAM.INF.H/M-V/G 202	HEAT EXCHANGER ACCESSORIES INCLUDED	ECHANGEUR CHALEUR ET ACCESSOIRES	WÄRMETAUSCHER KOMPLETT MIT ZUBEHÖR	INTERCAMBIADOR COMPLETO CON ACCESORIOS
7	R11224050	1	ASS.SCAMBIATORE. CAM.SUP.H/M-V/G 202	HEAT EXCHANGER ACCESSORIES INCLUDED	ECHANGEUR CHALEUR ET ACCESSOIRES	WÄRMETAUSCHER KOMPLETT MIT ZUBEHÖR	INTERCAMBIADOR COMPLETO CON ACCESORIOS
8	R58001480	12	BOCCOLA FISSAGGIO CANDELETTE	BUSH	DOUILLE	BUSCH	CASQUILLO
9	R63050140	2	CANDELA ACC.A/SM ø9.5 KA1 ø3/M4 Lot=139	IGNITOR	BOUGIE ALLUMAGE	ZUENDKERZE	BUJIA ENCENDIDO
10	R63050130	10	CANDELA ACCENSIONE A/SM ø9.5 KA1 ø3/M4	IGNITOR	BOUGIE ALLUMAGE	ZUENDKERZE	BUJIA ENCENDIDO
11	R66605811	2	CAVO ACC./RIL.CAM./BOIL. L=850 2 CAVI	FLAME IGNITION CABLE/FLAME SENSOR CABLE	CABLE ALLUMAGE/CONTROLE FLAME	ZUENDKABEL/FLAMMUEBERWACHUNGSKABEL	CABLE ENCENDIDO/SENSOR
12	R66605921	1	CAVO ACC./RIL.CAM./BOIL. L=400 2 CAVI	FLAME IGNITION CABLE/FLAME SENSOR CABLE	CABLE ALLUMAGE/CONTROLE FLAME	ZUENDKABEL/FLAMMUEBERWACHUNGSKABEL	CABLE ENCENDIDO/SENSOR
13	R66605150	2	CAVO ACCENS.C/CONNETT. A 90° D.6,3 L=500	FLAME IGNITION CABLE/FLAME SENSOR CABLE	CABLE ALLUMAGE/CONTROLE FLAME	ZUENDKABEL/FLAMMUEBERWACHUNGSKABEL	CABLE ENCENDIDO/SENSOR
14	R66605130	2	CAVO ACCENS.C/CONNETT.A 90° D.6,3 L=950	FLAME IGNITION CABLE/FLAME SENSOR CABLE	CABLE ALLUMAGE/CONTROLE FLAME	ZUENDKABEL/FLAMMUEBERWACHUNGSKABEL	CABLE ENCENDIDO/SENSOR
15	R62280078	4	CURVA POLYPR.HTB DN50 87,5° DIN EN1451-1	CURVE	COURBE	KURVE	CURVA
16	R62060223	3	DADO PILOTA TUBO D.6 0903/1.	NUT D.6	ECROU D. 6	MUTTER D.6	DADO D.6
17	R11430340	4	DIAFRAMMA VENTILATORE/BRUCIATORE D.22	ORIFICE D.22	DIAPHRAGME D.22	BLLENDE D.22	DIAFRAGMA D.22
18	R58004200	4	DISCO CALIBRATO ø4.5 mm	ORIFICE ø4,5 mm	DIAPHRAGME ø4,5 mm	BLLENDE ø4,5 mm	DIAFRAGMA ø4,5 mm
19	R62180152	1	FLEX GAS L=100 CM M/F1/2" INOX	GAS INLET FLEXIBLE PIPE	TUBE FLEXIBLE ENTREE GAZ	FLEXROHR GASZULAUF	TUBO FLEXIBLE ENTRADA GAS
20	R62180132	3	FLEX GAS L=50 CM M/F1/2" INOX	GAS INLET FLEXIBLE PIPE	TUBE FLEXIBLE ENTREE GAZ	FLEXROHR GASZULAUF	TUBO FLEXIBLE ENTRADA GAS
21	R63140060	2	GUARN. BRUC.-SCAMB. X BRUC. 18-27 KW	BURNER/HEAT EXCHANGER GASKET	JOINT BRULEUR / ECHANGEUR CALORIFIQUE	DICHTUNG BRENNER/WARMETAUSCHER	JUNTA QUEMADOR/INTERCAMBIADOR
22	R63140010	4	GUARN.BOIL.-COND.FUMI VM-G/061.	BURNER/FAN MOTOR GASKET	JOINT VENTILATEUR / BRULEUR	DICHTUNG GEBLASE/GASBRENNER	JUNTA VENTILADOR/QUEMADOR
23	R63140050	8	GUARN.VENTILATORE-BRUCIATORE	BURNER/FAN MOTOR GASKET	JOINT VENTILATEUR / BRULEUR	DICHTUNG GEBLASE/GASBRENNER	JUNTA VENTILADOR/QUEMADOR
24	R63140080	4	GUARNIZIONE SCAMB.-BRUC. De.126 18-27kW	BURNER/HEAT EXCHANGER GASKET	JOINT BRULEUR / ECHANGEUR CALORIFIQUE	DICHTUNG BRENNER/WARMETAUSCHER	JUNTA QUEMADOR/INTERCAMBIADOR
25	R70050090	4	GUARNIZIONE VALVOLA VENTURI INGRESSO LAT	VENTURI GASKET	JOINT VENTURI	DICHTUNG	JUNTA VENTURI
26	R70060121	4	MANICOTTO RIDUZIONE De.45,5 Di.35 (PA 6)	REDUCTION COUPLING	MANCHON REDUCTION	REDUZIERMUFFE	MANGUITO REDUCCION
27	R65320010	2	SONDA LIVELLO TL 10/B	PROBE	PROBE	PROBE	PROBE
28	R77700056	4,8m	TUBO FLEX c/Spirale Di.30 De.35,3 COMAP	AIR INLET FLEXIBLE PIPE	TUBE ASPIRATION AIR	LUFTANSAUGRUHR	TUBO ASPIRACION AIRE
29	R63020170	4	VALVOLA GAS VK41 15 V 1014 HON.	GAS SOLENOID VALVE	VALVE GAZ	GAS VENTIL	VALVULA GAS
30	R65060360	4	VENTILATORE RG128/1300-3612-020203	GAS BURNER FAN MOTOR	VENTILATEUR POUR BRULEUR GAZ	GEBLASEF.GASBRENNER	VENTILADOR PARA QUEMADOR GAS
31	R63120040	4	VENTURI VAL.GAS.BRUC.PREMIX45900444-002B	VENTURI TUBE	VENTURI	VENTURIROHR	VENTURI
32	R62070023	3	BICONO PILOTA TUBO D.6 905.	BICONE D.6	BICONE D. 6	KEGEL D.6	BICONO D.6
33	R66605801	1	CAVO ACC./RIL.CAM./BOIL. L=700 2 CAVI	FLAME IGNITION CABLE/FLAME SENSOR CABLE	CABLE ALLUMAGE/CONTROLE FLAME	ZUENDKABEL/FLAMMUEBERWACHUNGSKABEL	CABLE ENCENDIDO/SENSOR

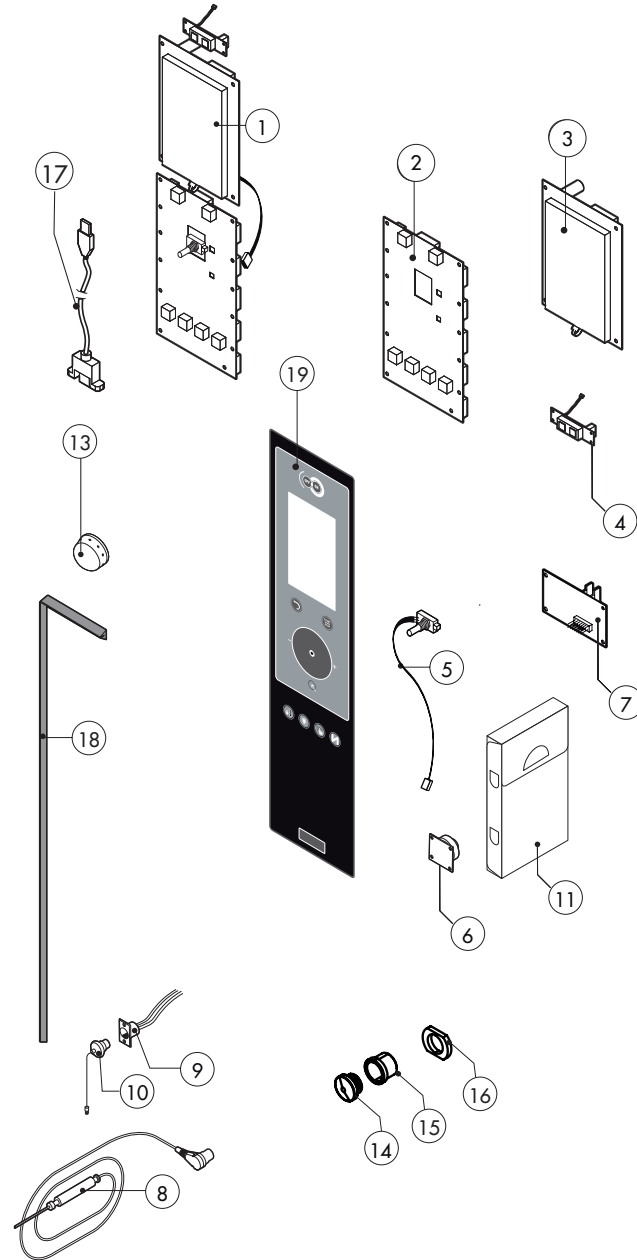

POS.	COD.	Pz.	DESCRIZIONE	DESCRIPTION	DESCRIPTION	BESCHREIBUNG	DESCRIPCION
1	R65301900	1	SCHEDA "X" 2006 COMPLETA	CONTROL PANEL PC BOARD "X"	PLATINE ÉLECTRONIQUE COMPLÈTE "X"	STEUERPLATINE KOMPLETT "X"	PLACA COMPLETA "X"
2	R65301910	1	SCHEDA BASE POTENZA TOP LCD "X" Sr.2006	MAIN PC BOARD "X"	FICHE PANNEAU PRINCIPAL "X"	HAUPTPLATINE "X"	PLACA BASE "X"
3	R65301920	1	SCHEDA DISPLAY TOP LCD "X" Sr.2006	DISPLAY PC BOARD "X"	PLATINE ÉLECTRONIQUE DISPLAY "X"	DISPLAYPLATINE "X"	PLACA DISPLAY "X"
4	R65301930	1	SCHEDA ON-OFF TOP LCD "X" Sr.2006	ON-OFF BOARD "X"	ON-OFF PANNEAU "X"	ON-OFF PLATINE "X"	ON-OFF PLACA "X"
5	R65301940	1	ENCODER LCD "X" SR.2006	FRONT PC BOARD ENCODER	ENCODER PLATINE	ENCODER F. PLATINE	ENCODER PLACA ELECTRONICA
6	R65301960	1	SCHEDA BUZZER TOP LCD "X" Sr.2006	PC BOARD BUZZER	SONNERIE PLATINE	PLATINENSUMMER	ZUMBADOR PLACA ELECTRONICA
7	R65301950	1	SCHEDA ESPANSIONE BRUCIATORI "X" Sr.2006	BOILER CONTROL PC BOARD	FICHE ELECTRON. CONTROLE CHAUDIERE	ESPANSIONSPLATINE	PLACA EXPANSION
8	R65321102	1	SONDA AL CUORE K 4 PUNTI 6 PIN.IMP.2012	CORE TEMPERATURE PROBE	SONDE A COEUR	KERNTEMPERATURFUEHLER	SONDA AL CORAZON
9	R65321110	1	CONNETTORE FEMM. S/CUORE 6 PIN	CORE TEMPERATURE PROBE FEMALE CON- NECTOR	CONNECTEUR FEMELLE POUR SONDE A COUER	STECKDOSE F. KERNTEMPERATURFUEHLER	CONECTOR HEMBRA PARA SONDA AL CORAZON
10	R65321020	1	TAPPO X CONNETTORE 4 PIN.	COVER FOR CONNECTOR	BOUCHON POUR CONNECTEUR	ABDECKUNG STECKDOSE	TAPON PARA CONECTOR
11	R86020400	1	VALIGETTA X SONDA AL CUORE TRASPA- RENTE	CORE TEMPERATURE PROBE BOX	PETITE VALISE SONDE A COEUR	TASCHE F. KERNTEMPERATURFUEHLER	ESTUCHE DE SONDA AL CORAZON
13	R69030270	1	MANOPOLA ENCODER D.60 BLU FA 6264	KNOB KIT	POIGNEE COMMANDE	DREHKNOFF	PULSADOR MANETA
14	R65321290	1	ASS.TAPPO PER PRESA USB 2012	COVER	BOUCHON	ABDECKUNG	TAPON
15	R65321250	1	BOCCOLA PER PRESA USB 2012	BUSH	DOUILLE	BUSCH	CASQUILLO
16	R58004380	1	DADO PER PRESA USB 2012	NUT	ECROU	MUTTER	TUERCA
17	R65010350	1	CAVO COLL. SCHEDA/PRESA USB HEART L=750	PC BOARD CONNECETION USB	CABLE USB POUR LA PLATINE	REIHENKABLE USB FÜR PLTINEVERBINDUNG	CABLE USB CONEXIÓN FICHA
18	R80100100	2,2	GUARNIZIONE CRUSCOTTO	GASKET	JOINT	RINGDICHTUNG	JUNTA
19		1	TASTIERA	PLATE	PLAQUE	BEDIENUNGSFOLIE	TARJETA

ATTENZIONE: PER TENSIONI SPECIALI, SPECIFICARE SEMPRE IL MODELLO DI FORNO ED IL NUMERO DI MATRICOLA
ATTENTION: FOR SPECIAL VOLTAGES, PLEASE ALWAYS SPECIFY THE OVEN MODEL AND THE SERIAL NUMBER

ATTENTION: POUR TENSIONS SPÉCIALES, MERCI DE SPÉCIFIER TOUJOURS LE MODÈLE DU FOUR ET LE NUMÉRO DE SÉRIE
ACHTUNG: BEI SONDRSPANNUNGEN, BITTE IMMER OFEN-MODELL UND SERIENNUMMER GEBEN.

ed. 0713

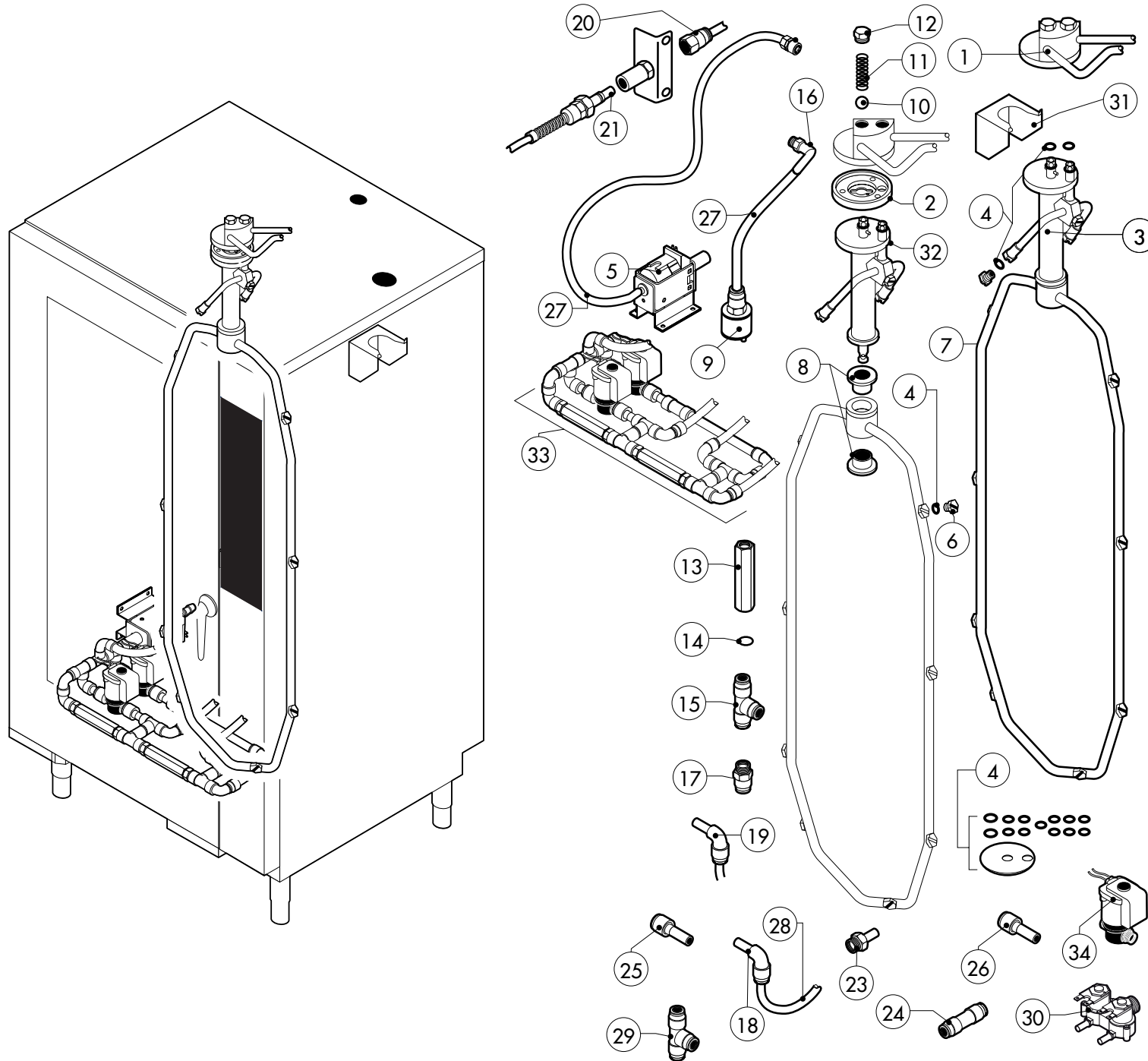

ATTENZIONE: PER ORDINARE I RICAMBI, SPECIFICARE SEMPRE IL MODELLO DI FORNO ED IL NUMERO DI MATRICOLA
ATTENTION: WHEN ORDERING SPARE PARTS, PLEASE ALWAYS SPECIFY THE OVEN MODEL AND THE SERIAL NUMBER

ATTENTION: POUR COMMANDER DES PIÈCES, MERCI DE SPECIFIER TOUJOURS LE MODÈLE DU FOUR ET LE NUMÉRO DE SÉRIE
ACHTUNG: UM ERSATZTEILE ZU BESTELLEN, BITTE IMMER OFEN-MODELL UND SERIENNUMMER GEBEN.

ed. 0713

POS.	COD.	Pz.	DESCRIZIONE	DESCRIPTION	DESCRIPTION	BESCHREIBUNG	DESCRIPCIÓN
1	R11214290	1	ASS.BLOCCO EST.LAV.CAM.K_G202	WASHING SYSTEM EXTERNAL ASSEMBLY	ENSEMBLE EXTERIEUR DU LAVAGE	EXTERNE WASCHARMBEFESTIGUNG	BLOQUE EXTERNO LAVADO
2	R58004960	1	FLANGIA INTERNA LAVAGGIO	WASHING SYSTEM INNER FLANGE	BRIDE INTERIEUR BRAS DE LAVAGE	INNEN FLANSCH WASCHARMBEFESTIGUNG	PLATINA INTERNA LAVADO
3	R11100540	1	BRACCIO LAVAGGIO COMPLETO M/202	WASHING DEVICE ASSEMBLY	BRAS DE RINCAGE COMPLET	WASHARM KOMPLETT	BRAZO LAVADO COMPLETO
4	R70045100	1	KIT GUARNIZIONI	GASKETS KIT	ENSEMBLE JOINTS	DICHTUNGSSATZ	KIT JUNTAS
5	R65110600	1	POMPA ELETTROM.A PIS.OSC.ET508.	DETRGENT PUMP	POMPE DETERGEANT	REINIGERPUMPE	BOMBA DETERGENTE
6	R62210032	8	UGELLO LAVAGGIO 1,3 L/MIN	1,3 L/MIN RINSING JET	GICLEUR LAVAGE 1,3 LITRE/MINUTE	SPULDUSE REINIGUNG 1,3L/MIN	INYEKTOR LAVADO 1,3 L/MIN
7	R62210052	4	UGELLO OVK 110ø 0,30 L/MIN 1,5BAR	0,30 L/MIN DETERGENT JET	GICLEUR DETERGENT 0,30 LITRE/MINUTE	SPULDUSE REINIGER 0,30 L/MIN	INYEKTOR DETERGENTE 0,30 L/MIN
8	R58004980	2	BOCCOLA ROTAZIONE BRACCIO LAVAGGIO	WASHING DEVICE ROTATION BUSH	COQUILLE ROTATION BRAS LAVAGE	DEEHBUCHESE F. WASCHARM	CASQUILLO ROTACION BRAZO LAVADO
9	R65110650	1	VALVOLA DI FONDO PER FILTRO GM.060.35	BOTTOM FILTER	FILTER POUR TUBE DETERGEANT	ANSAUGFILTER F. REINIGUNGSSCHAUCH	VÁLVULA DE FONDO TUBO DEL LIMPIADOR
10	R62220012	2	SFERA D. 14	SPHERA D.14	SPHERE D. 14	VERSCHLUSSKUGEL D.14	ESFERA D.14
11	R61620041	2	MOLLA	SPRING	RESSORT	FEDER	MUELLE
12	R58005000	2	TAPPO MASCHIO 1/2"	1/2" MALE COVER	BOUCHON 1/2"	MUTTERSTOPFEN 1/2"	TAPON MACHO 1/2"
13	R65110680	2	VALVOLA ANTIRITORNO J.G. 10SCV	ANTI-BACK FLOW	ANTIRETOUR	RUCKFLUSSVERHINDERER	ANTIRETORNO
14	R70010050	4	GUARNIZIONE OR 7,60x2,62	JOINT OR 7,60x2,62	OR GASKETS	RINGDICHTUNG 7,60X2,62	VIDRIO OR 7,60x2,62
15	R62090468	5	RACCORDO INTERMEDIO A "T" D.10	T MIDLING PIPE FITTING D.10	RACCORD INTERMEDIAIRE A "T" D.10	MITTELVERBINDUNGSSTUCK D.10 "T"- FORMIG	RACOR INTERMEDIO TIPO "T" D.10
16	R62090678	2	RACC.A GOMITO C/CODOLO 8X8 PM220808E	ELBOW PIPE FITTING (WITH TANG) 8 X 8	COURBE AVEC QUEUE 8x8	WINKELVERBINDUNGSSTUCK 8X8 MIT SCHAFT	RACOR DE GOMA CON CODO 8x8
17	R62090688	1	RACC.TERMIN.DIR.FIL.CON.8X1/4 NC2500-P	8x1/4 STRAIGHT THREADED TERMINAL PIPE FITTING	RACCORD FILETE DROIT 8x1/4"	ENDVERBINDUNGSSTUCK 8x1/4" GESCHNITTEN	RACOR TERMINAL DERECHO ROSCADO 8x1/4"
18	R62090528	6	RACCORDO A GOMITO CON CODOLO 10x10	ELBOW PIPE FITTING (WITH TANG) 10 X 10	COURBE AVEC QUEUE 10x10	WINKELVERBINDUNGSSTUCK 10 X 10 MIT SCHAFT	RACOR DE GOMA CON CODO 10x10
19	R62090808	2	GOMITO CON CODOLO ø6-ø6 PM220606E	8X1/8 END SIDE PIPE FITTING (WITH TANG)	RACCORD AVEC QUEUE 8x1/8"	ENDVERBINDUNGSSTUCK 8 X 1/8" MOT SCHAFT	RACOR TERMINAL CON CODO 8x1/8"
20	R62090538	1	RACCORDO DIRITTO FEMMINA 1/4" PER TUBO D.8x6	1/4" FEMALE STRAIGHT PIPE FITTING FOR D.6X8 PIPE	RACCORD DROIT PARTIE FEMELLE 1/4" TUBE 6x8	VERBINDUNGSSTUCK 1/4" WEBL. FÜR ROHR D.6X8	RACOR DERECHO HEMBRA 1/4" PARA TUBO D.6x8
21	R62090482	1	RACCORDO RAPIDO MASCHIO	RAPID MALE PIPE FITTING	RACCORD RAPIDE PARTIE MALE	SCHNELLEVERBINDUNG MANNL	RACOR RAPIDO MACHO
22	R62090638	1	RACC.RAP.FEMM.X LAV.FIL.FEMM PVPU40-F1/4	RAPID FEMALE PIPE FITTING	RACCORD RAPIDE PARTIE FEMELLE	SCHNELLEVERBINDUNG	RACOR RAPIDO HEMBRA
23	R62090608	2	RACCORDO TERMINALE C/CODOLO 8x1/8"	8X1/8 END SIDE PIPE FITTING (WITH TANG)	RACCORD AVEC QUEUE 8x1/8"	ENDVERBINDUNGSSTUCK 8 X 1/8" MOT SCHAFT	RACOR TERMINAL CON CODO 8x1/8"
24	R62090458	1	RACCORDO INTERMEDIO DRITTO D.10	PIPE FITTING	COURBE	STUCK	RACOR
25	R62090618	2	RACCORDO DIRITTO RIDUZIONE 10-8	REDUCTION PIPE FITTING	RACCORD DROIT REDUCTION	GERADE ANSCHLUSS-VERKLEINERUNG	RACOR DERECHO REDUCCION
26	R62090548	4	RACCORDO DIRITTO RIDUZIONE 10-6	REDUCTION PIPE FITTING	RACCORD DROIT REDUCTION	GERADE ANSCHLUSS-VERKLEINERUNG	RACOR DERECHO REDUCCION
27	R80150020	2	TUBO PE D.8mm x 6	PIPE	TUBE	LEITUNG	TUBO
28	R80150030	1	TUBO PE D.10mm x 7 (3 MT.)	PIPE	TUBE	LEITUNG	TUBO
29	R62090488	1	RACCORDO INTERMEDIO A "T" D.6 PM0206E	T MIDLING PIPE FITTING	RACCORD INTERMEDIAIRE A "T"	MITTELVERBINDUNGSSTUCK "T"- FORMIG	RACOR INTERMEDIO TIPO "T"
30	R65110210	1	ELETR. 2 VIE 220V 50HZ X J.G..	SOLENOID VALVE 220V 50HZ WITH FLOW REDUCER	ELECTROVANNE 220V 50HZ AVEC REG.DE DEBIT	MAGNETVENTIL 220V 50HZ MIT DRUCKMINDERER	ELECTROVALVULA DOBLE 220V 50HZ C/ REDUCT.
31	R11402000	1	SUPPORTO ESTERNO BRACCIO LAVAGGIO	WASHING DEVICE EXTERNAL HOLDER	SUPPORT EXTERIEUR BRAS DE LAVAGE	WANDHALTERUNG FÜR WASHARM	SOPORTE EXTERNO BRAZO LAVADO
32	R14102550	1	TUBO SUPPORTO BRACCIO LAVAGGIO T06-M/072	TUBE DEVICE SUPPORT WASHING	TUBE JE SUPPORTE DISPOSITIF LAVAGE	HALTERUNGSROHRWASCHRAUM	TUBO SUPORTE BRAZO LAVADO
33	R62300068	1	GRUPPO ANTIRIT.+SVUOT.COND.K_202	ANTI-BACK FLOW DEVICE ASSEMBLY	GROUPE JE COMPLÈTE ANTI-RETOUR	KOMPLET RÜCKFLUSSVENTIL SATZ	KIT ANTIRETORNO COMPLETO
34	R65110260	2	ELETTROV.SR.7 NA JOHN GUEST D.6 230V50HZ	SOLENOID VALVE D.6 230V 50HZ	ELECTROVANNE D.6 230V 50HZ	MAGNETVENTIL D.6 230V 50HZ	ELECTROVALVULA D.6 230V 50HZ
35	R70070080	1	TUBO GOMMA PER ALIMENTI Di13 De23 L=1MT	PIPE	TUBE	LEITUNG	TUBO

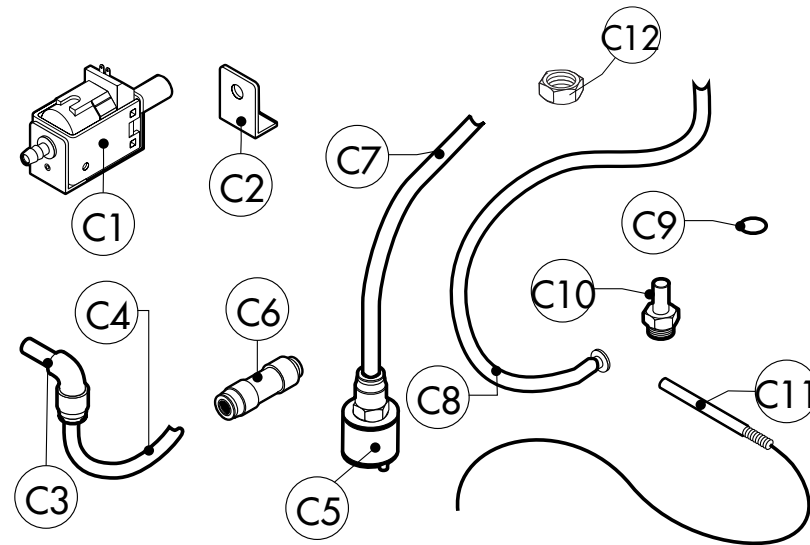

ATTENZIONE: PER ORDINARE I RICAMBI, SPECIFICARE SEMPRE IL MODELLO DI FORNO ED IL NUMERO DI MATRICOLA
ATTENTION: WHEN ORDERING SPARE PARTS, PLEASE ALWAYS SPECIFY THE OVEN MODEL AND THE SERIAL NUMBER

ATTENTION: POUR COMMANDER DES PIECES, MERCI DE SPECIFIER TOUJOURS LE MODELE DU FOUR ET LE NUMERO DE SERIE
ACHTUNG: UM ERSATZTEILE ZU BESTELLEN, BITTE IMMER OFEN-MODELL UND SERIENNUMMER GEBEN.

ed. 0713

POS.	COD.	Pz.	DESCRIZIONE	DESCRIPTION	DESCRIPTION	BESCHREIBUNG	DESCRIPCIÓN
C1	R65110620	1	POMPA ELETTRON.A PIS.OSC.HF 230V/50HZ	PUMP	POMPE	PUMPE	POMPA
C2	R65110630	2	SUPPORTO ELLE POMPA HF	PUMP HOLDER	SUPPORT POUR POMPE	GESTELL FUER PUMPE	SOPORTE PARA POMPA
C3	R62090808	2	GOMITO CON CODOLO ø6-ø6 PM220606E	ELBOW PIPE FITTING	COURBE AVEC QUEUE	WINKELVERBINDUNGSSTUCK MIT SCHAFT	RACOR DE GOMA CON CODO
C4	R80150050	1,6	TUBO PE 6MMX4	WATER FLEXIBLE PIPE	TUBE FLEXIBLE EAU	WASSERFLEXROHRLEITUNG	TUBO FLEXIBLE AGUA
C5	R65110650	1	VALVOLA DI FONDO PER FILTRO GM.060.35	VALVE	DRAINAGE	ABLAUFVENTIL	VALVULA
C6	R62090798	2	RIDUZIONE INTER.DRITTA ø8-ø6 PM200806E	REDUCTION	REDUCTION	VERRINGERUNG	REDUCCION
C7	R80150020	2	TUBO PE 8MMX6 TRASPARENTE	WATER FLEXIBLE PIPE	TUBE FLEXIBLE EAU	WASSERFLEXROHRLEITUNG	TUBO FLEXIBLE AGUA
C8	R11429630	1	TUBO INGRESSO ANTICALCARE BOILER CAL-OUT	CALOUT FLEXIBLE PIPE	TUBE FLEXIBLE POUR CALOUT	CALOUT FLEXROHRLEITUNG	TUBO FLEXIBLE CALOUT
C9	R62070023	1	BICONO PILOTA TUBO D.6 905.	BICONE D.6	BICONE D.6	KEGEL D.6	BICONO D.6
C10	R62060223	1	DADO PILOTA TUBO D.6 0903/1.	NUT D.6	ECROU D.6	MUTTER D.6	DADO D.6
C11	R65324550	1	SONDA LIVELLO CALOUT TL 10/B EL=20 TF=15	LEVEL PROBE	SONDE DE NIVEAU	WASSERSSTANDSFUEHLER	SONDA NIVEL
C12	R62060193	1	DADO PER CODOLO DA 1/2	NUT	ECROU	MUTTER	DADO