

ATTENZIONE: PER TENSIONI SPECIALI, SPECIFICARE SEMPRE IL MODELLO DI FORNO ED IL NUMERO DI MATRICOLA
ATTENTION: FOR SPECIAL VOLTAGES, PLEASE ALWAYS SPECIFY THE OVEN MODEL AND THE SERIAL NUMBER

ATTENTION: POUR TENSIONS SPÉCIALES, MERCI DE SPÉCIFIER TOUJOURS LE MODÈLE DU FOUR ET LE NUMÉRO DE SÉRIE
ACHTUNG: BEI SONDRSPANNUNGEN, BITTE IMMER OFEN-MODELL UND SERIENNUMMER GEBEN.

ed. 0614

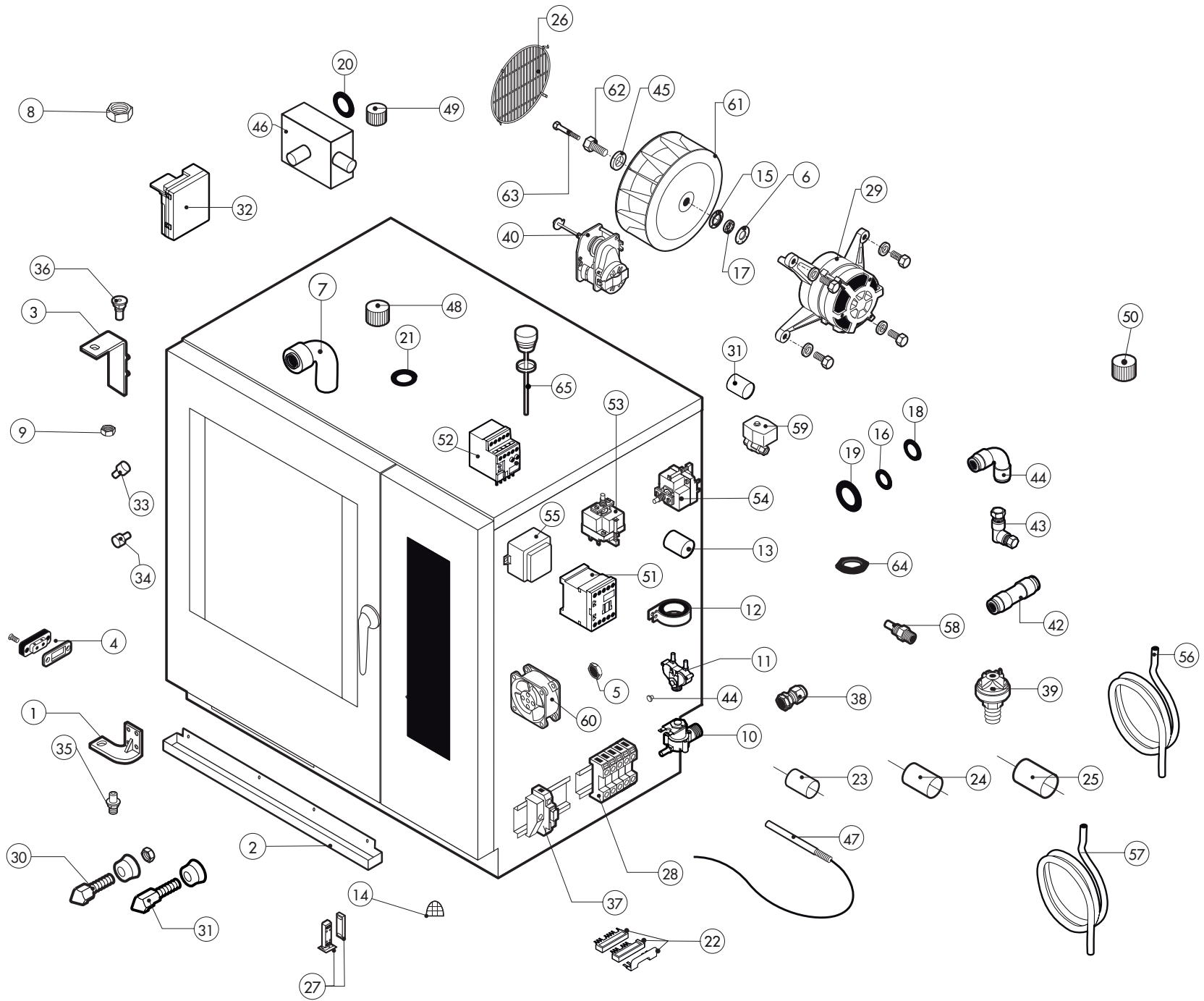

POS.	COD.	Pz.	DESCRIZIONE	DESCRIPTION	DESCRIPTION	BESCHREIBUNG	DESCRIPCIÓN
1	R11207240	1	ASS.CERNIERA INF. M-V/061-101-102 2005	LOWER DOOR HINGE	CHARNIERE INFERIEURE PORTE	UNTERES SCHARNIER	BISAGRA INFERIOR
2	R69180170	1	BACINELLA SCARICO H-101	DRIP TRAY	PLATEAU D'ÉGOUTTEMENT	WASSERTROPFTASSE	BANDEJA DEL GOTEÓ
3	R11426830	1	CERNIERA SUPER.PORTE SR.2013	UPPER DOOR HINGE	CHARNIERE SUPERIEURE PORTE	OBERES SCHARNIER	BISAGRA SUPERIOR
4	R65260750	1	CONTATTO PER LUCI SR.2000	LAMPS CONTACT BLOCK	CONTACT ECLAIRAGE	LICHTKONTSCHALTER	CONTACTO PARA LUZ
5	R65240020	1	CONTRODADO PG 116/16/NY	CABLE GLAND LOCK NUT	CONTRE-ECROU POUR RONDELLE FIXATION	MUTTER	CONTRODADO PASACABLE
6	R58003850	1	CONTROFLANGIA GUARN. GRANDE	MOTOR GASKET BRASS COUNTER FLANGE	CONTRE- BRIDE JOINT MOTEUR	GEGENFLANSCH F. MOTORDICHTUNG	CONTRABRIDA JUNTA MOTOR
7	R62280038	1	CURVA C/MORSET.HTS-HTSW X TUBO D.50 D.50X	CURVE WITH TERMINAL	COURBE AVEC BORNIER	KURVE MIT KLEMM	CURVA CON REGLETERA
8	R58006900	2	DADO INOX 1"1/2	NUT	ECROU	MUTTER	TUERCA
9	R58004050	2	DADO PER PERNO CERNIERA REG. M/106-220	NUT FOR UPPER DOOR HINGE	ECROU CHEVILLE CHARNIERE SUPERIEURE	MUTTER F. OBERES SCHARNIERSTIFT	TUERCA PARA PERNO BISAGRA SUPERIOR
10	R65110200	1	E.V. 1 VIA 220V 50HZ X J.G.CON ATTACC	SOLENOID VALVE	ELECTROVANNE	MAGNETVENTIL	ELECTROVALVULA
11	R65110210	1	E.V. 2 VIE 220V 50HZ X J.G.CON ATTACC	SOLENOID VALVE 220V 50HZ	ELECTROVANNE 220V 50HZ	MAGNETVENTIL 220V 50HZ	ELECTROVALVULA 220V 50HZ
12	R65280490	1	FERRITE TOROIDALE FT36	FERRITE FT36	FERRITE FT36	FERRIT FT36	FERRITA FT36
13	R65280230	1	FILTRO FLC330501F	INTERFERENCE SUPPRESSOR	FILTRE ANTIPARASITES	STOERSCHUTZFILTER	FILTRO
14	R69180250	1	FILTRO SCARICO BACINELLA	SUPPRESSOR	FILTRE	FILTER	FILTRO
15	R58003840	1	FLANGIA GUARN.GRANDE	MOTOR GASKET BRASS FLANGE	BRIDE JOINT MOTEUR	FLANSCH F. MOTORDICHTUNG	BRIDA JUNTA MOTOR
16	R70010030	1	GUARNIZIONE OR 6,07 X 1,78 SILICONE	JOINT OR 6,07 X 1,78	OR GASKETS 6,07 X 1,78	RINGDICHTUNG 6,07 X 1,78	JUNTA OR 6,07 X 1,78
17	R70020050	1	GUARNIZIONE MARK IV MLA 2400.02.05	JOINT	GASKETS	DICHTUNG	JUNTA
18	R70010210	1	GUARNIZIONE OR NBR 70 18,72x2,62 C.3075	JOINT OR 18,72x2,62	OR GASKETS 18,72x2,62	RINGDICHTUNG 18,72x2,62	JUNTA
19	R65070230	1	GUARNIZIONE PER TERM.SIC.CA-MERM/106-110	JOINT	GASKETS	DICHTUNG	JUNTA
20	R70050150	1	GUARNIZIONE X TAPPO 2" PLAST.G40005	JOINT	GASKETS	RINGDICHTUNG	JUNTA
21	R70050140	1	GUARNIZIONE X TAPPO BOYLER PLAST. G40015	JOINT	GASKETS	RINGDICHTUNG	JUNTA
22	R65140370	1	KIT INVERSIONE X TELERUTT. 4KW SIEMENS	INVERSION KIT FOR CONTACTOR 4KW	KIT D'INVERSION POUR CONTACTEUR 4KW	KIT WENDEN SCHUETZ 4KW	KIT INVERSION CONTACTOR 4KW
23	R70060080	1	MANICOTTO SILICONE D.13X18X80	SILICON SLEEVE	SILICONE SLEEVE	SILIKONHÜLLE	FUNDA DE SILICONA
24	R70060020	1	MANICOTTO SILICONE D.30X35X9 TAPPO SFIA	SILICON SLEEVE	SILICONE SLEEVE	SILIKONHÜLLE	FUNDA DE SILICONA
25	R70060050	3	MANICOTTO SILICONE D.60	SILICON SLEEVE	SILICONE SLEEVE	SILIKONHÜLLE	FUNDA DE SILICONA
26	R75300090	1	MASCHERINA VENTILATORE D.350	FAN GUARD GRID D.350	GRILLE VENTILATEUR D.350	VENTILATORSCHUTZGITTER D.350	REJILLA VENTILADOR D.350
27	R65265100	1	MICRO PORTA MAGNETICO COMPLETO RIC.	DOOR SWITCH	MICRO PORTE	TUERSCHALTER	MICRO PUERTA
28	R65220280	1	MORSETTIERA MONOFASE C/TERRA PAS-SANTE	TERMINAL BOARD	BORNIER	KLEMMLEISTE	REGLETERA
29	R65040550	1	MOTORE KW055 F14P 3039 200-240V50-60HZ I	MOTOR	MOTEUR	MOTOR	MOTOR
30	R69010260	1	NASELLO 1 STEP 6303-020022	DOOR LATCH 1 STEP	GACHE DE PORTE POUR OUVERTURE SIMPLE	SCHLISSNASE 1 STUFE	NARIZ 1 CIERRE
31	R69010270	1	NASELLO 2 STEP 6303-020030	DOOR LATCH 2 STEP	GACHE DE PORTE POUR OUVERTURE	SCHLISSNASE 2 STUFE	NARIZ 2 CIERRE
32	R63060160	2	PANNELLO ACCENS. S4565C1116B Ts=5 Tps=1	BURNER IGNITION PANEL	ALLUMEUR GAZ	ZUENDBOX	PANEL DE ENCENDIDO
33	R58003140	2	PERNO AGGANCIAMENTO DEFLETTORE	FAN GUARD PANEL PIN	PIVOT DEFLECTEUR	BOLZEN FÜR LUFTLEITBLECH	PERNO CIERRE DEFLECTOR
34	R58003110	2	PERNO FISSAGGIO DEFLETTORE	FAN GUARD PANEL PIN	PIVOT DEFLECTEUR	BOLZEN FÜR LUFTLEITBLECH	PERNO CIERRE DEFLECTOR
35	R58002670	1	PERNO INF. CERNIERA REG.C/FERMI SR.2005	LOWER HINGE PIN	CHEVILLE CHARNIERE INFERIEURE	UNTERES SIE SCHARNIERSTIFT	PERNO INFERIOR BISAGRA
36	R58002150	1	PERNO SUP. CERNIERA REG. M/106-220	UPPER HINGE PIN	CHEVILLE CHARNIERE SUPERIEURE	OBERES SCHARNIERSTIFT	PERNO SUPERIOR BISAGRA
37	R65210020	5	PORTAFUSIBILE BARRA DIN 5x20	FUSE CARRIER	PORTE-FUSIBLE	SICHERUNGSHALTER	PORTAFUSIBILE
38	R65240010	1	PRESSACAVO PG 107 Z/16	FAIRLEAD	PRESSE CABLE	ZUGENTLASTUNG	PRENSACABLES
39	R63070010	1	PRESSOSTATO PG 901.61	GAS SAFETY PRESSURE SWITCH	INT.A PRESSION SECURITE-GAZ	DRUCKSCHALTER PG	PRESOSTATO GAS

POS.	COD.	Pz.	DESCRIZIONE	DESCRIPTION	DESCRIPTION	BESCHREIBUNG	DESCRIPCIÓN
40	R65090220	1	PROGRAMMAT. 1 CAMME V220/50HZ 1 CIRCUITO	DAMPER SYSTEM	SORTIE EVAPORATION MOUFLE	DAMPFABLASS-STELLMOTOR	MOTOR RESPIRADERO COMPLETO
41	R62090478	2	RACC. INTERMEDIO A GOMITO D.10 PM0310E	ELBOW PIPE FITTING	COURBE AVEC QUEUE	STUCK MIT SCHAFT	RACOR CON CODO
42	R62090458	2	RACC. INTERMEDIO DIRITTO D.10 PM0410E	PIPE FITTING	COURBE	STUCK	RACOR
43	R62090633	1	RACCORDO OTTONE CURVO 10/10 C/OGIVA	ELBOW PIPE FITTING BRASS D.10	RACCORDEMENT A COUDE LAITON D 10	WINKELSTUTZEN AUS MESSING D,10	RACOR LATON DE GOMA D.10
44	R65110510	1	REGOL. PORTATA ROSSO ALPHATECH. 15LT/H	1.5 LT/H WATER FLOW REDUCER	REGULATUER DE DEBIT 1.5 LT.	DURCHFLUSSMONDERER 1.5L/STD.	REGULADOR DE CAUDAL 1.5 LT.
45	R58004010	1	ROND. FISS. VENTOLA D 30/12.5	FAN WASHER Ø 30/12.5	RONDELLE TURBINE Ø 30/12.5	UNTERLEGSCHLEIBE Ø 30/12.5	ARANDELA FIJACION TURBINA Ø 30/12.5
46	R69180110	1	SCATOLA COND.SCARICO H/MV 102	QUENCHING-DRAIN COLLECTOR	BOITE DE CONDENSATION DECHARGE	KONDENSATION-ABFLUSS SCHACHTEL	CAJON CONDENSACION-DESAGÜE
47	R65320220	3	SONDA "K" 6X80 1,5ML. TESTA RASTREM.20mm	PROBE "K" 6X80 1,5ML.	SONDE "K" 6X80 1,5ML.	FUEHLER "K" 6X80 1,5ML.	SONDA "K" 6X80 1,5ML.
48	R69150110	1	TAPPO FEMMINA G 1"1/4 PP+25%FV NERO	COVER	BOUCHON	ABDECKUNG	TAPON
49	R69150100	1	TAPPO FEMMINA G 2" PP+25%FV NERO	COVER	BOUCHON	ABDECKUNG	TAPON
50	R58005070	1	TAPPO TANICA VERDE x CALOUT	COVER	BOUCHON	ABDECKUNG	TAPON
51	R65140380	2	TELERUTTORE 3RT1016-1AP02	CONTACTOR	CONTACTEUR	SCHUETZ	CONTACTOR
52	R65160590	1	TERM. MOT. 3RU1116-1EBO 2,8-4,0 SIEMENS	THERMIC PROTECTION 3RU1116-1EBO 2,8-4,0A	PROTECTION THERMIQUE 3RU1116-1EBO 2,8-4,0A	MOTORSCHUTZSCHALTER 3RU1116-1EBO 2,8-4,0A	TERMICO 3RU1116-1EBO 2,8-4,0A
53	R65070350	1	TERMOSTATO SICUR. 360°C -25K 55.32572.8	THERMOSTAT	THERMOSTAT	THERMOSTAT	TERMOSTATO
54	R65070081	1	TERMOSTATO SICUR. BOILER M/1065532522852	THERMOSTAT	THERMOSTAT	THERMOSTAT	TERMOSTATO
55	R65180420	2	TRASF.RE 20VA 0-220-240/12V MOD.163.16	TRANSFORMER 20VA	TRANSFORMATEUR 20VA	TRANSFORMATOR 20VA	TRANSFORMADOR 20VA
56	R80150000	4	TUBO PE 10MMX7 AZZURRO PM950612E	BLUE PIPE	TUBE	LEITUNG	TUBO
57	R80120060	1	TUBO SILIC. TRASP.SR60/TR 7/12.	PIPE	TUBE	LEITUNG	TUBO
58	R58006160	2	UGELLO COND.D.0,8 CODOLO CIL.10	NOZZLE	BEC	DÜSE	BOQUILLA
59	R65110560	1	VALV. A SFERA MOTOR. 220V 3/4"	STEAM GENERATOR DRAIN MOTORIZED VALVE	DRAINAGE CHAUDIERE	BOILERABLAUFVENTIL	VALVULA DE BOLA MOTORIZADA
59	R65110570	1	VALV. A SFERA MOTOR. 2 VIE 230V 1" DAL 24.10.2012	STEAM GENERATOR DRAIN MOTORIZED VALVE 2 VIE 230V 1" FROM 24.10.2012	DRAINAGE CHAUDIERE 2 VIE 230V 1" DU 24.10.2012	BOILERABLAUFVENTIL 2 VIE 230V 1" VOM 24.10.2012	VALVULA DE BOLA MOTORIZADA 2 VIE 230V 1" DEL 24.10.2012
60	R65060050	2	VENTILATORE COMPATTO D.120 4715MS 23T	COMPONENTS VENTILATION MOTOR	MOTEUR DE REFROIDISSEMENT	ABKÜLUNGS MOTOR	MOTOR DE ENFRIAMIENTO
61	R75400550	1	VENTOLA D.325/300X125/12 50HZ P.D.	FAN	TURBINE	LUEFTERRAD	PALA VENTILADOR
62	R58004000	1	VITE FISSAGGIO VENTOLA M12x1.5 SX	FAN SCREW M12x1.5 SX	VIS DE BLOCAGE TURBINE M12x1.5 SX	VENTILATORSCHRAUBE M12x1.5 SX	TORNILLO FIJACION TURBINA M12x1.5 SX
63	R61020562	1	VITE MOTORE TE A2 M6x55	MOTOR SCREW TE A2 M6x55	VIS DE BLOCAGE MOTEUR TE A2 M6x55	MOTORSCHRAUBE TE A2 M6x55	TORNILLO MOTOR TE A2 M6x55
64	R70010120	1	GUARNIZIONE SILICONE ROSSO 90X90X3	RED GASKET	JOINT ROUGE	ROTEN DICHTUNG	JUNTA ROJA
65	R10100140	1	TAPPO SFIATO COMPLETO M/106.-.220	COVER	BOUCHON	ABDECKUNG	TAPON
66	R65190040	1	CONDENSATORE 20MF	CAPACITOR	CONDENSATEUR	KONDENSATOR	CONDENSADOR

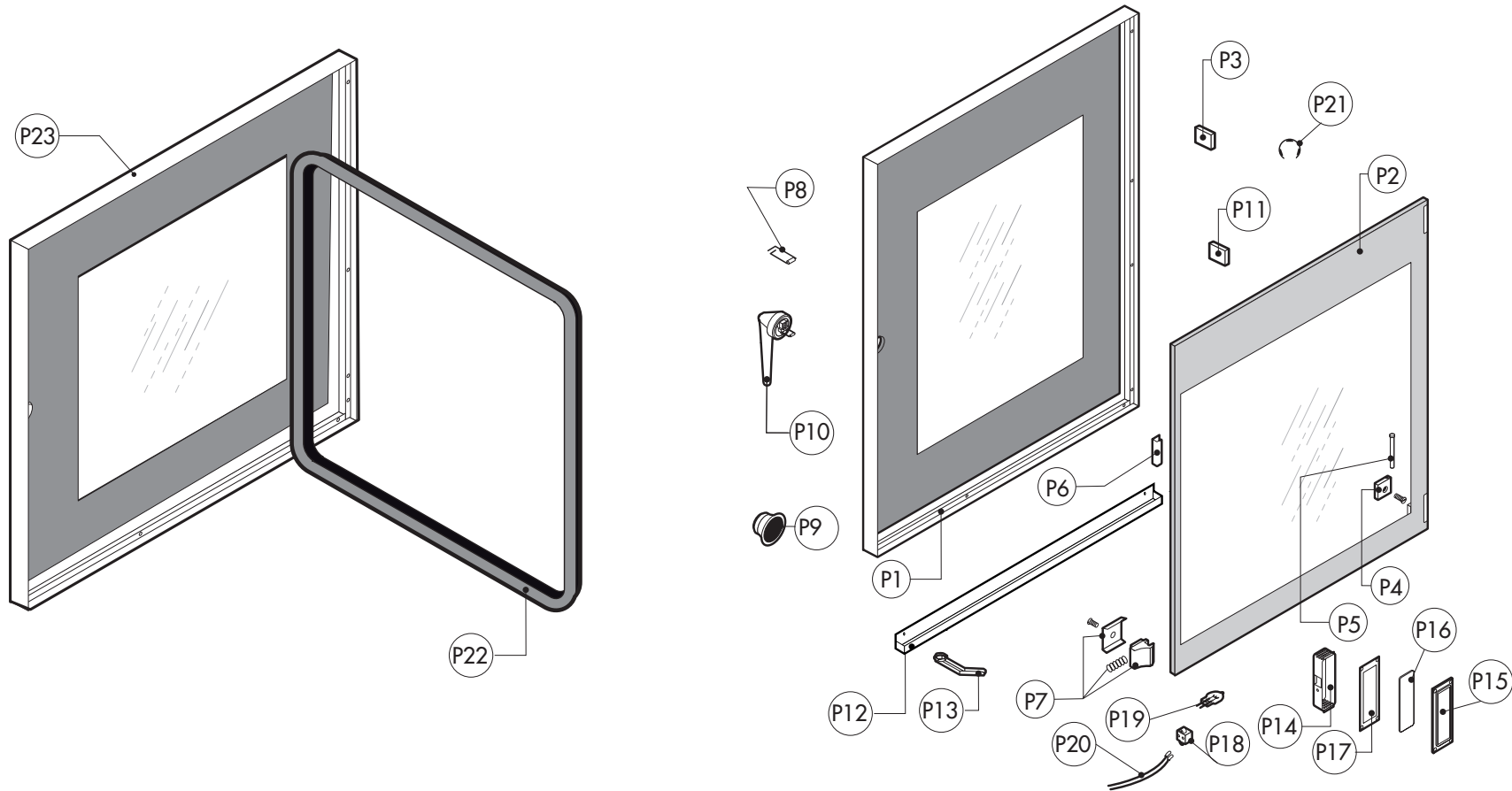

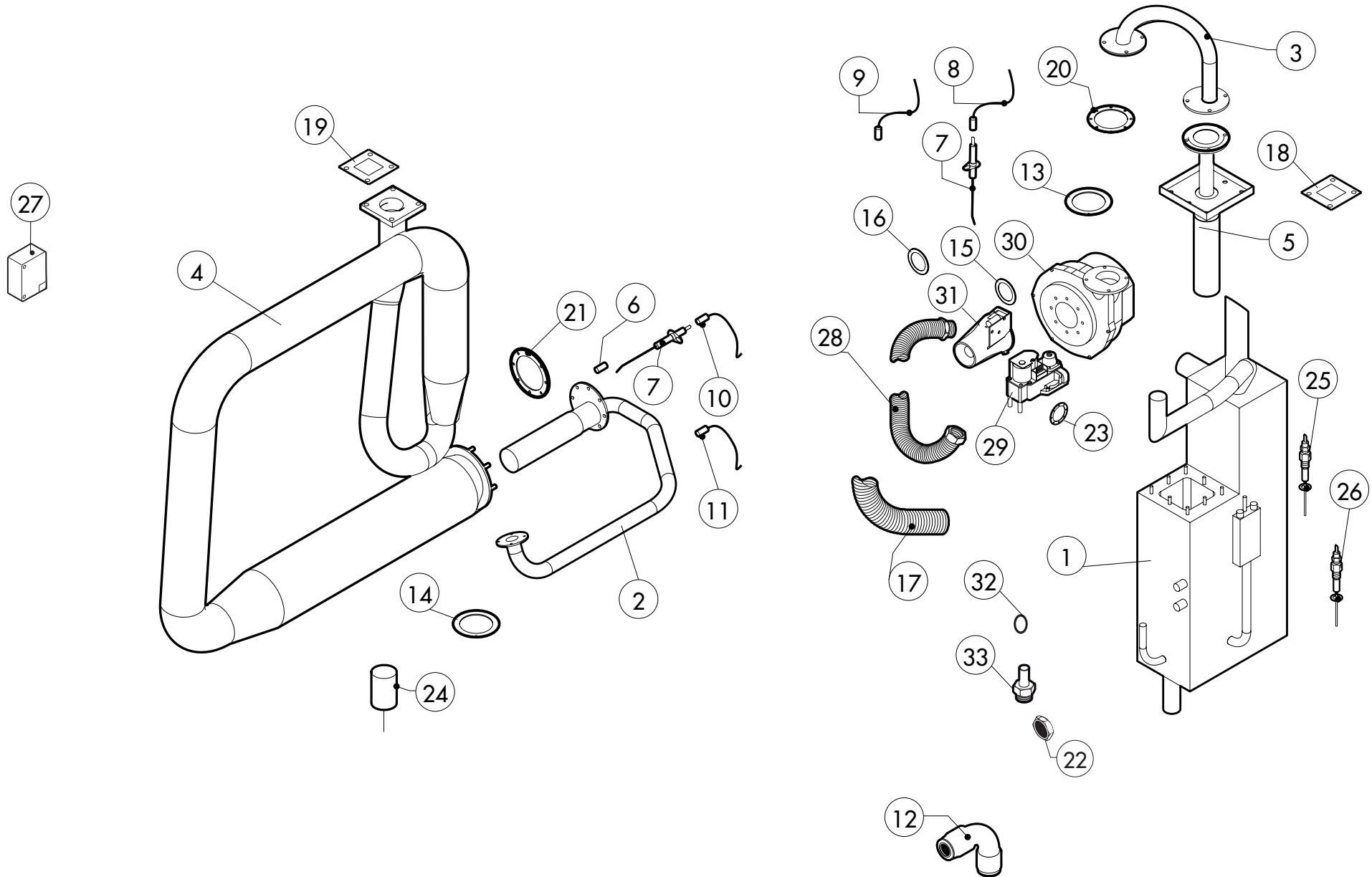

POS.	COD.	Pz.	DESCRIZIONE	DESCRIPTION	DESCRIPTION	BESCHREIBUNG	DESCRIPCIÓN
1	R11209050	1	ASS. BOILER C/CAL-OUT KMG072	STEAM GENERATOR ASSEMBLY	CHAUDIÈRE COMPLETE	DAMPFERZEUGER KOMPLETT	BOILER COMPLETO
1	R11209151	1	ASS. BOILER C/CAL-OUT KMG072 DAL 24.10.2012	STEAM GENERATOR ASSEMBLY FROM 24.10.2012	CHAUDIÈRE COMPLETE DU 24.10.2012	DAMPFERZEUGER KOMPLETT VOM 24.10.2012	BOILER COMPLETO DEL 24.10.2012
2	R11207190	1	ASS. BRUCIATORE CAMERA KMG072-102	COOKING CABINET BURNER	BRÛLEUR MOUFLE	GARRAUMBRENNER	QUEMADOR CAMERA
3	R11209030	1	ASS. COLETTORE TESTATA BRUC. BOILER KMG072	BURNER HEAD COLLECTOR ASSEMBLY	ENSEMBLE COLLECTEUR TÊTE BRÛLEUR	BRENNERKOPF-ZULAUFLEITUNG	COLECTOR QUEMADOR CALDERA KMG072
4	R11209010	1	ASS. SCAMBIATORE CAMERA K_G072	HEAT EXCHANGER ACCESSORIES INCLUDED	ECHANGEUR CHALEUR ET ACCESSOIRES	WÄRMETAUSCHER KOMPLETT MIT ZUBEHÖR	INTERCAMBIADOR COMPLETO CON ACCESORIOS
5	R11209060	1	ASS. TESTATA BRUC. BOILER KMG072	BOILER BURNER HEAD ASSEMBLY	ENSEMBLE TÊTE BRÛLEUR CHAUDIÈRE	BRENNERKOPF	TESTADA QUEMADOR CALDERA KMG072
6	R58001480	3	BOCCOLA FISSAGGIO CANDELETTE	BUSH	DOUILLE	BUSCH	CASQUILLO
7	R63050130	6	CANDELA ACCENSIONE A/SM ø9.5 KA1 ø3/M4	IGNITOR	BOUGIE ALLUMAGE	ZUENDKERZE	BUJIA ENCENDIDO
8	R66605811	2	CAVO ACC./RIL. CAM./BOIL. L=850	FLAME IGNITION CABLE/FLAME SENSOR CABLE	CABLE ALLUMAGE/CONTROLE FLAME	ZUENDKABEL/FLAMMUEBERWACHUNGSKABEL	CABLE ENCENDIDO/SENSOR
9	R66605921	2	CAVO ACC./RIL. CAM./BOIL. L=400	FLAME IGNITION CABLE/FLAME SENSOR CABLE	CABLE ALLUMAGE/CONTROLE FLAME	ZUENDKABEL/FLAMMUEBERWACHUNGSKABEL	CABLE ENCENDIDO/SENSOR
10	R66605150	1	CAVO ACCENS.C/CONNETT.A 90° D.6,3 L=500	FLAME IGNITION CABLE/FLAME SENSOR CABLE	CABLE ALLUMAGE/CONTROLE FLAME	ZUENDKABEL/FLAMMUEBERWACHUNGSKABEL	CABLE ENCENDIDO/SENSOR
11	R66605130	1	CAVO ACCENS.C/CONNETT.A 90° D.6,3 L=950	FLAME IGNITION CABLE/FLAME SENSOR CABLE	CABLE ALLUMAGE/CONTROLE FLAME	ZUENDKABEL/FLAMMUEBERWACHUNGSKABEL	CABLE ENCENDIDO/SENSOR
12	R62280078	2	CURVA POLYPR.HTB DN50 87,5° DIN EN1451-1	CURVE	COURBE	KURVE	CURVA
13	R11430350	1	DIAFRAMMA VENTILATORE/BRUCIATORE D.18	ORIFICE D.18	DIAPHRAGME D.18	BLLENDE D.18	DIAFRAGMA D.18
14	R11430340	1	DIAFRAMMA VENTILATORE/BRUCIATORE D.22	ORIFICE D.22	DIAPHRAGME D.22	BLLENDE D.22	DIAFRAGMA D.22
15	R58004190	1	DISCO CALIBRATO ø4 mm	ORIFICE ø4 mm	DIAPHRAGME ø4 mm	BLLENDE ø4 mm	DIAFRAGMA ø4 mm
16	R58004200	1	DISCO CALIBRATO ø4,5 mm	ORIFICE ø4,5 mm	DIAPHRAGME ø4,5 mm	BLLENDE ø4,5 mm	DIAFRAGMA ø4,5 mm
17	R62180122	4	FLEX GAS L=25-50 CM M/F1/2" INOX	GAS INLET FLEXIBLE PIPE	TUBE FLEXIBLE ENTREE GAZ	FLEXROHR GASZULAUF	TUBO FLEXIBLE ENTRADA GAS
18	R63140060	1	GUARN. BRUC.-SCAMB. X BRUC. 18-27 KW	BURNER/HEAT EXCHANGER GASKET	JOINT BRULEUR / ECHANGEUR CALORIFIQUE	DICHTUNG BRENNER/WARMETAUSCHER	JUNTA QUEMADOR/INTERCAMBIADOR
19	R63140010	2	GUARN. BOIL.-COND. FUMI VM-G/061	BURNER/FAN MOTOR GASKET	JOINT VENTILATEUR / BRULEUR	DICHTUNG GEBLASE/GASBRENNER	JUNTA VENTILADOR/QUEMADOR
20	R63140050	5	GUARN. VENTILATORE-BRUCIATORE	BURNER/FAN MOTOR GASKET	JOINT VENTILATEUR / BRULEUR	DICHTUNG GEBLASE/GASBRENNER	JUNTA VENTILADOR/QUEMADOR
21	R63140080	2	GUARNIZIONE SCAMB.-BRUC. De.126 18-27 kW	BURNER/HEAT EXCHANGER GASKET	JOINT BRULEUR / ECHANGEUR CALORIFIQUE	DICHTUNG BRENNER/WARMETAUSCHER	JUNTA QUEMADOR/INTERCAMBIADOR
22	R62060223	1	DADO PILOTA TUBO D.6 0903/1.	NUT D.6	ECROU D. 6	MUTTER D.6	DADO D.6
23	R70050090	2	GUARNIZIONE VALVOLA VENTURI INGRESSO LAT	VENTURI GASKET	JOINT VENTURI	DICHTUNG	JUNTA VENTURI
24	R70060121	2	MANICOTTO RIDUZIONE De.45,5 Di.35 (PA 6)	REDUCTION COUPLING	MANCHON REDUCTION	REDUZIERMUFFE	MANGUITO REDUCCION
25	R65320010	2	SONDA LIVELLO TL 10/B	LEVEL PROBE	SONDE DE NIVEAU	WASSERSSTANDSFUEHLER	SONDA NIVEL
26	R65324550	1	SONDA LIVELLO CALOUT TL 10/B EL=20 TF=15	LEVEL PROBE	SONDE DE NIVEAU	WASSERSSTANDSFUEHLER	SONDA NIVEL
27	R65180270	2	TRASF. ACCENS. COFI TRK2-3PVD	IGNITION TRANSFORMER	TRANSFORMATEUR D'ALLUMAGE	ZÜNDTRANSFORMATOR	TRANSFORMADOR DE ENCENDIDO DESDE
28	R77700056	2,5m	TUBO FLEX c/Spirale Di.30 De.35,3 COMAP	AIR INLET FLEXIBLE PIPE	TUBE ASPIRATION AIR	LUFTANSAUGRUHR	TUBO ASPIRACION AIRE
29	R63020170	2	VALVOLA GAS VK4115 V 1014 HON.	GAS SOLENOID VALVE	VALVE GAZ	GAS VENTIL	VALVULA GAS
30	R65060360	2	VENTILATORE RG128/1300-3612-020203	GAS BURNER FAN MOTOR	VENTILATEUR POUR BRULEUR GAZ	GEBLASEF. GASBRENNER	VENTILADOR PARA QUEMADOR GAS
31	R63120030	2	VENTURI VALV. GAS. BRUC. PREMIX45900446-053	VENTURI TUBE	VENTURI	VENTURIROHR	VENTURI
32	R62070023	1	BICONO PILOTA TUBO D.6 905.	BICONE D.6	BICONE D. 6	KEGEL D.6	BICONO D.6
33	R62060213	2	DADO CON BICONO D. 6 0958031.	NUT WITH BICONE	ECROU AVEC BICONE	MUTTER MIT KEGEL	TUERCA CON BICONO

ATTENZIONE: PER TENSIONI SPECIALI, SPECIFICARE SEMPRE IL MODELLO DI FORNO ED IL NUMERO DI MATRICOLA
ATTENTION: FOR SPECIAL VOLTAGES, PLEASE ALWAYS SPECIFY THE OVEN MODEL AND THE SERIAL NUMBER

ATTENTION: POUR TENSIONS SPÉCIALES, MERCI DE SPÉCIFIER TOUJOURS LE MODÈLE DU FOUR ET LE NUMÉRO DE SÉRIE
ACHTUNG: BEI SONDRERSPANNUNGEN, BITTE IMMER OFEN-MODELL UND SERIENNUMMER GEBEN.

ed. 0614

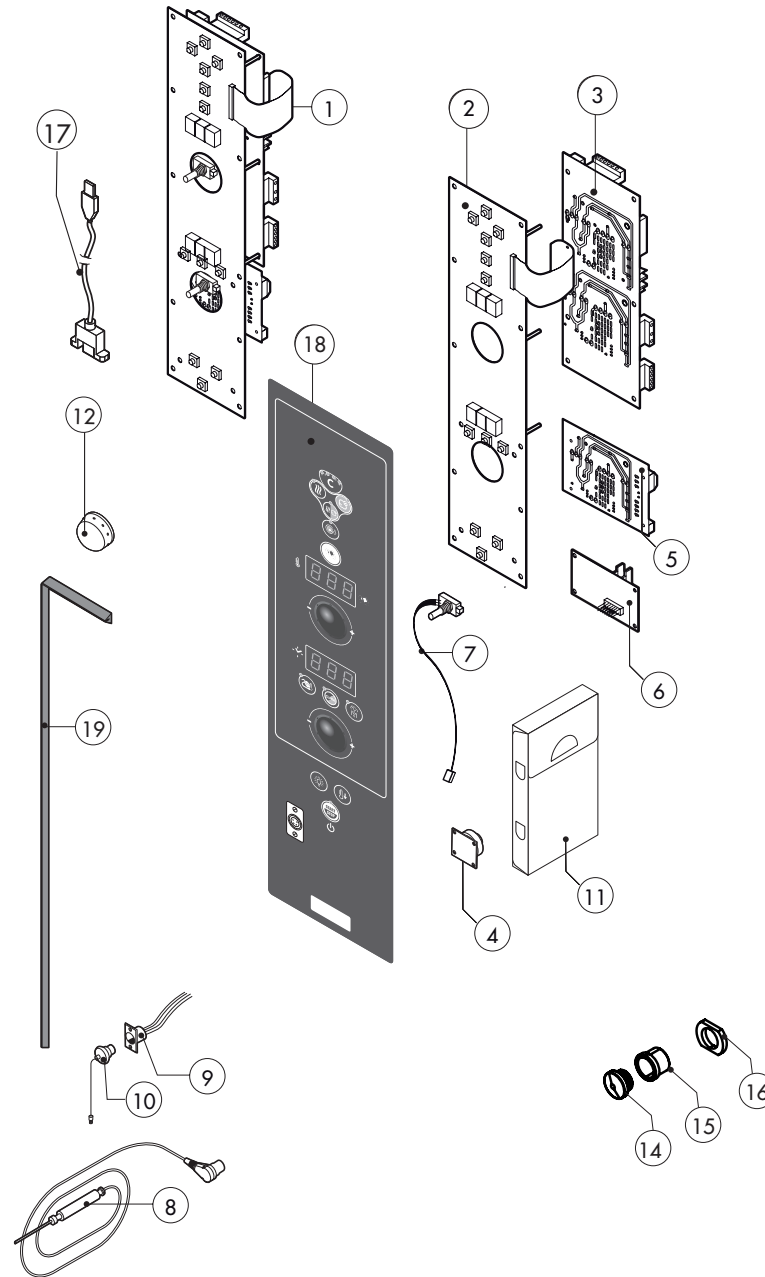

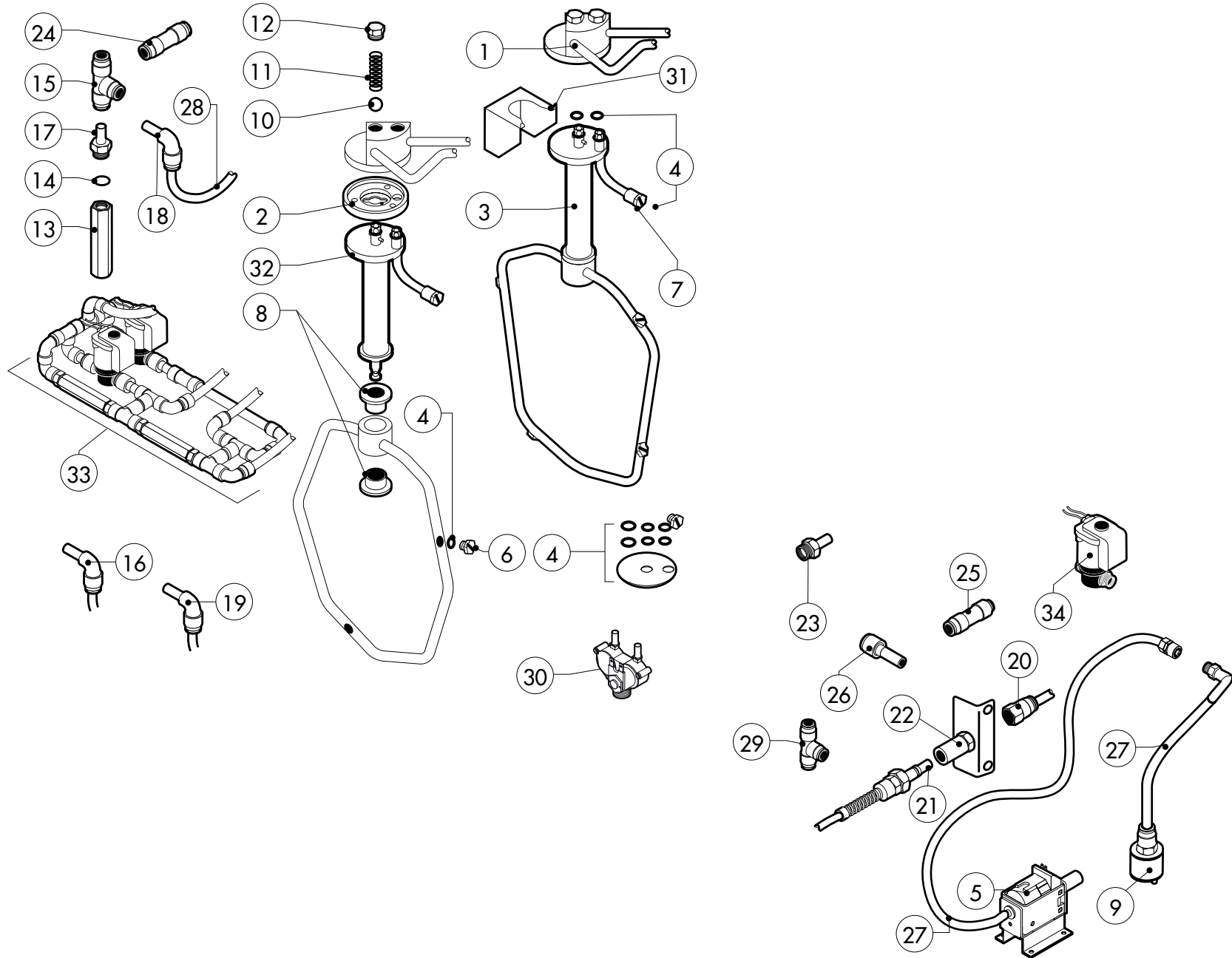

POS.	COD.	Pz.	DESCRIZIONE	DESCRIPTION	DESCRIPTION	BESCHREIBUNG	DESCRIPCIÓN
1	R11212160	1	BLOCCO ESTERNO LAVAGGIO	WASHING SYSTEM EXTERNAL ASSEMBLY	ENSEMBLE EXTERIEUR DU LAVAGE	EXTERNE WASCHARMBEFESTIGUNG	BLOQUE EXTERNO LAVADO
2	R58004960	1	FLANGIA INTERNA LAVAGGIO	WASHING SYSTEM INNER FLANGE	BRIDE INTERIEUR BRAS DE LAVAGE	INNEN FLANSCH WASCHARMBEFESTIGUNG	PLATINA INTERNA LAVADO
3	R11100440	1	BRACCIO LAVAGGIO COMPLETO	WASHING DEVICE ASSEMBLY	BRAS DE RINCAGE COMPLET	WASHARM KOMPLETT	BRAZO LAVADO COMPLETO
4	R70045100	1	KIT GUARNIZIONI	GASKETS KIT	ENSEMBLE JOINTS	DICHTUNGSSATZ	KIT JUNTAS
5	R65110600	1	POMPA ELETTROM.A PIS.OSC.ET508.	DETRGENT PUMP	POMPE DETERGEANT	REINIGERPUMPE	BOMBA DETERGENTE
6	R62210032	4	UGELLO LAVAGGIO 1,3 L/MIN	1,3 L/MIN RINSING JET	GICLEUR LAVAGE 1,3 LITRE/MINUTE	SPULDUSE REINIGUNG 1,3L/MIN	INYEKTOR LAVADO 1,3 L/MIN
7	R62210052	4	UGELLO OVK 110 \varnothing 0,30 L/MIN 1,5BAR	0,30 L/MIN DETERGENT JET	GICLEUR DETERGENT 0,30 LITRE/MINUTE	SPULDUSE REINIGER 0,30 L/MIN	INYEKTOR DETERGENTE 0,30 L/MIN
8	R58004980	2	BOCCOLA ROTAZIONE BRACCIO LAVAGGIO	WASHING DEVICE ROTATION BUSH	COQUILLE ROTATION BRAS LAVAGE	DEEHBUCHESE F. WASCHARM	CASQUILLO ROTACION BRAZO LAVADO
9	R65110650	1	VALVOLA DI FONDO PER FILTRO GM.060.35	BOTTOM FILTER	FILTER POUR TUBE DETERGEANT	ANSAUGFILTER F. REINIGUNGSSCHAUCH	VÁLVULA DE FONDO TUBO DEL LIMPIADOR
10	R62220012	2	SFERA D. 14	SPHERA D.14	SPHERE D. 14	VERSCHLUSSKUGEL D.14	ESFERA D.14
11	R61620041	2	MOLLA	SPRING	RESSORT	FEDER	MUELLE
12	R58005000	2	TAPPO MASCHIO 1/2"	1/2" MALE COVER	BOUCHON 1/2"	MUTTERSTOPFEN 1/2"	TAPON MACHO 1/2"
13	R65110680	2	VALVOLA ANTIRITORNO J.G. 10SCV	ANTI-BACK FLOW	ANTIRETOUR	RUCKFLUSSVERHINDERER	ANTIRETORNO
14	R70010050	4	GUARNIZIONE OR 7,60x2,62	GASKETS	JOINT	RINGDICHTUNG	JUNTA
15	R62090468	4	RACCORDO INTERMEDIO A "T" D.10	T MIDLING PIPE FITTING D.10	RACCORD INTERMEDIAIRE A "T" D.10	MITTELVERBINDUNGSSTUCK D.10 "T"- FORMIG	RACOR INTERMEDIO TIPO "T" D.10
16	R62090678	2	RACC.A GOMITO C/CODOLO 8X8 PM220808E	ELBOW PIPE FITTING (WITH TANG) 8 X 8	COURBE AVEC QUEUE 8x8	WINKELVERBINDUNGSSTUCK 8X8 MIT SCHAFT	RACOR DE GOMA CON CODO 8x8
17	R62090688	1	RACC.TERMIN.DIR.FIL.CON.8X1/4 NC2500-P	8x1/4 STRAIGHT THREADED TERMINAL PIPE FITTING	RACCORD FILETE DROIT 8x1/4"	ENDVERBINDUNGSSTUCK 8x1/4" GESCHNITTEN	RACOR TERMINAL DERECHO ROSCADO 8x1/4"
18	R62090528	5	RACCORDO A GOMITO CON CODOLO 10x10	ELBOW PIPE FITTING (WITH TANG) 10 X 10	COURBE AVEC QUEUE 10x10	WINKELVERBINDUNGSSTUCK 10 X 10 MIT SCHAFT	RACOR DE GOMA CON CODO 10x10
19	R62090808	2	GOMITO CON CODOLO \varnothing 6- \varnothing 6 PM220606E	8X1/8 END SIDE PIPE FITTING (WITH TANG)	RACCORD AVEC QUEUE 8x1/8"	ENDVERBINDUNGSSTUCK 8 X 1/8" MOT SCHAFT	RACOR TERMINAL CON CODO 8x1/8"
20	R62090538	1	RACCORDO DIRITTO FEMMINA 1/4" PER TUBO D.8x6	1/4" FEMALE STRAIGHT PIPE FITTING FOR D.6X8 PIPE	RACCORD DROIT PARTIE FEMELLE 1/4" TUBE 6x8	VERBINDUNGSSTUCK 1/4" WEBL. FÜR ROHR D.6x8	RACOR DERECHO HEMBRA 1/4" PARA TUBO D.6x8
21	R62090482	1	RACCORDO RAPIDO MASCHIO	RAPID MALE PIPE FITTING	RACCORD RAPIDE PARTIE MALE	SCHNELLEVERBINDUNG MANNL	RACOR RAPIDO MACHO
22	R62090638	1	RACC.RAP.FEMM.X LAV.FIL.FEMM PVPU40-F1/4	RAPID FEMALE PIPE FITTING	RACCORD RAPIDE PARTIE FEMELLE	SCHNELLEVERBINDUNG	RACOR RAPIDO HEMBRA
23	R62090608	2	RACCORDO TERMINALE C/CODOLO 8x1/8"	8X1/8 END SIDE PIPE FITTING (WITH TANG)	RACCORD AVEC QUEUE 8x1/8"	ENDVERBINDUNGSSTUCK 8 X 1/8" MOT SCHAFT	RACOR TERMINAL CON CODO 8x1/8"
24	R62090458	1	RACCORDO INTERMEDIO DRITTO D.10	PIPE FITTING	COURBE	STUCK	RACOR
25	R62090618	1	RACCORDO DIRITTO RIDUZIONE 10-8	REDUCTION PIPE FITTING	RACCORD DROIT REDUCTION	GERADE ANSCHLUSS-VERKLEINERUNG	RACOR DERECHO REDUCCION
26	R62090548	2	RACCORDO DIRITTO RIDUZIONE 10-6	REDUCTION PIPE FITTING	RACCORD DROIT REDUCTION	GERADE ANSCHLUSS-VERKLEINERUNG	RACOR DERECHO REDUCCION
27	R80150020	2	TUBO PE D.8mm x 6	PIPE	TUBE	LEITUNG	TUBO
28	R80150030	1	TUBO PE D.10mm x 7 (3 MT.)	PIPE	TUBE	LEITUNG	TUBO
29	R62090488	1	RACCORDO INTERMEDIO A "T" D.6 PM0206E	T MIDLING PIPE FITTING	RACCORD INTERMEDIAIRE A "T"	MITTELVERBINDUNGSSTUCK "T"- FORMIG	RACOR INTERMEDIO TIPO "T"
30	R65110210	1	ELETTR. 2 VIE 220V 50 HZ X J.G.	SOLENOID VALVE 220V 50HZ	ELECTROVANNE 220V 50HZ	MAGNETVENTIL 220V 50HZ	ELECTROVALVULA DOBLE 220V
31	R11402000	1	SUPPORTO ESTERNO BRACCIO LAVAGGIO	WASHING DEVICE EXTERNAL HOLDER	SUPPORT EXTERIEUR BRAS DE LAVAGE	WANDHALTERUNG FÜR WASHARM	SOPORTE EXTERNO BRAZO LAVADO
32	R14102550	1	TUBO SUPPORTO BRACCIO LAVAGGIO T06-M/072	TUBE DEVICE SUPPORT WASHING	TUBE JE SUPPORTE DISPOSITIF LAVAGE	HALTERUNGSROHRWASCHRAUM	TUBO SUPORTE BRAZO LAVADO
33	R62300058	1	GRUPPO ANTIRIT.+SVUOT.COND.K_102-072-201	ANTI-BACK FLOW DEVICE ASSEMBLY	GROUPE JE COMPLÈTE ANTI-RETOUR	KOMPLET RÜCKFLUSSVENTIL SATZ	KIT ANTIRETORNO COMPLETO
34	R65110260	2	ELETTROV.SR.7 NA JOHN GUEST D.6 230V 50HZ	SOLENOID VALVE D.6 230V 50HZ	ELECTROVANNE D.6 230V 50HZ	MAGNETVENTIL D.6 230V 50HZ	ELECTROVALVULA D.6 230V 50HZ
35	R70070080	1	TUBO GOMMA PER ALIMENTI Di13 De23 L=1MT	PIPE	TUBE	LEITUNG	TUBO

