

**ATTENZIONE:** PER TENSIONI SPECIALI, SPECIFICARE SEMPRE IL MODELLO DI FORNO ED IL NUMERO DI MATRICOLA  
**ATTENTION:** FOR SPECIAL VOLTAGES, PLEASE ALWAYS SPECIFY THE OVEN MODEL AND THE SERIAL NUMBER

**ATTENTION:** POUR TENSIONS SPÉCIALES, MERCI DE SPÉCIFIER TOUJOURS LE MODÈLE DU FOUR ET LE NUMÉRO DE SÉRIE  
**ACHTUNG:** BEI SONDRSPANNUNGEN, BITTE IMMER OFEN-MODELL UND SERIENNUMMER GEBEN.

ed. 0914

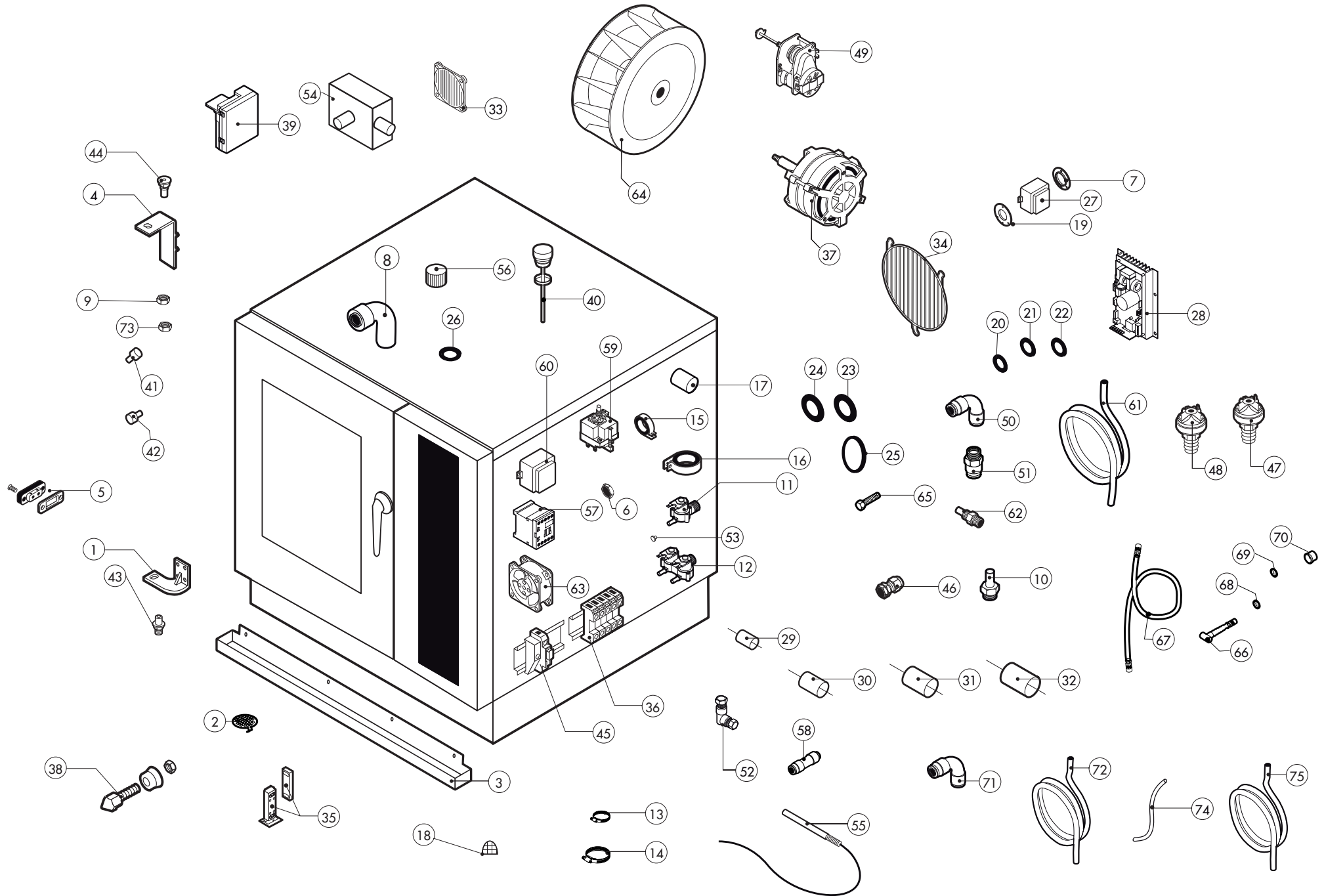

POS.	COD.	Pz.	DESCRIZIONE	DESCRIPTION	DESCRIPTION	BESCHREIBUNG	DESCRIPCIÓN
1	R11207240	1	ASS.CERNIERA INF. M-V/061-101-102 2005	LOWER DOOR HINGE	CHARNIERE INFERIEURE PORTE	UNTERES SCHARNIER	BISAGRA INFERIOR
2	R10201710	1	ASS.FILTRO DI SCARICO D.86/44.5 M/210-12	DRAIN FILTER	FILTRE ENCEINTE	ABFLUSSFILTER	FILTRO DESAGUE
3	R69180210	1	BACINELLA SCARICO N/S071-101 2014	DRIP TRAY	PLATEAU D'ÉGOUTTEMENT	WASSERTROPFTASSE	BANDEJA DEL GOTEO
4	R14402130	1	CERNIERA SUPERIORE PORTA N/S 2014	UPPER DOOR HINGE	CHARNIERE SUPERIEURE PORTE	OBERES SCHARNIER	BISAGRA SUPERIOR
5	R65260750	1	CONTATTO PER LUCI SR.2000	LAMPS CONTACT BLOCK	CONTACT ECLAIRAGE	LICHTKONTSCHALTER	CONTACTO PARA LUZ
6	R65240020	1	CONTRODADO PG 116/16/NY	CABLE GLAND LOCK NUT	CONTRE-ECROU POUR RONDELLE FIXATION	MUTTER	CONTRODADO PASACABLE
7	R58003870	1	CONTROFLANGIA GUARN.PICCOLA	MOTOR GASKET BRASS COUNTER FLANGE	CONTRE- BRIDE JOINT MOTEUR	GEGENFLANSCH F. MOTORDICHTUNG	CONTRABRIDA JUNTA MOTOR
8	R62280038	1	CURVA C/MORSET.HTS-HTSW X TUBO D.50 D.50X	CURVE WITH TERMINAL	COURBE AVEC BORNIER	KURVE MIT KLEMM	CURVA CON REGLETERA
9	R58004050	1	DADO PER PERNO CERNIERA REG. M/106-220	NUT FOR UPPER DOOR HINGE	ECROU CHEVILLE CHARNIERE SUPERIEURE	MUTTER F. OBERES SCHARNIERSTIFT	TUERCA PARA PERNO BISAGRA SUPERIOR
10	R62060223	1	DADO PILOTA TUBO D.6 0903/1.	NUT D.6	ECROU D. 6	MUTTER D.6	DADO D.6
11	R65110200	1	E.V. 1 VIA 220V 50HZ X J.G.CON ATTACC FINO ALLA SETTIMANA 10/2015	SOLENOID VALVE 1 VIE 220V 50HZ UNTIL WEEK 10/2015	ELECTROVANNE 1 VIE 220V 50HZ ÉLIMINÉ DU SEMAINE 10/2015	MAGNETVENTIL 1 VIE 220V 50HZ BIS WOCHEN 10/2015	ELECTROVALVULA 1 VIE 220V 50HZ ELIMINATO DEL SEMANA 10/2015
11	R65110320	1	E.V. 1 VIA 230V 50/60HZ OUT J.G. D.10 DALLA SETTIMANA 10/2015	SOLENOID VALVE 1 VIA 230V 50/60HZ OUT J.G. D.10 SINCE WEEK 10/2015	ELECTROVANNE 1 VIA 230V 50/60HZ OUT J.G. D.10 DU SEMAINE 10/2015	MAGNETVENTIL 1 VIA 230V 50/60HZ OUT J.G. D.10 VOM WOCHEN 10/2015	ELECTROVALVULA 1 VIA 230V 50/60HZ OUT J.G. D.10 DEL SEMANA 10/2015
12	R65110230	1	E.V. 2 VIE 1P+1D 220V/50HZ J. G. CON ATTACC FINO ALLA SETTIMANA 10/2015	SOLENOID VALVE 2 VIE 220V 50HZ UNTIL WEEK 10/2015	ELECTROVANNE 2 VIE 220V 50HZ ÉLIMINÉ DU SEMAINE 10/2015	MAGNETVENTIL 2 VIE 220V 50HZ BIS WOCHEN 10/2015	ELECTROVALVULA 2 VIE 220V 50HZ ELIMINATO DEL SEMANA 10/2015
12	R65110340	1	E.V. 2VIE 1PD+1D 230V 50/60HZ OUT J.G. D.10 DALLA SETTIMANA 10/2015	SOLENOID VALVE 1PD+1D 230V 50/60HZ OUT J.G. D.10 SINCE WEEK 10/2015	ELECTROVANNE 1PD+1D 230V 50/60HZ OUT J.G. D.10 DU SEMAINE 10/2015	MAGNETVENTIL 1PD+1D 230V 50/60HZ OUT J.G. D.10 VOM WOCHEN 10/2015	ELECTROVALVULA 1PD+1D 230V 50/60HZ OUT J.G. D.10 DEL SEMANA 10/2015
13	R61630011	2	FASCETTE ZINC.12-22/9	METAL CLAMPS 12-22/9	COLLIER DE SERRAGE 12-22/9	VERZINKTE SCHELLEN 12-22/9	ABRAZADERA 12-22/9
14	R61630031	4	FASCETTE ZINC.40-60/9	METAL CLAMPS 40-60/9	COLLIER DE SERRAGE 40-60/9	VERZINKTE SCHELLEN 40-60/9	ABRAZADERA 40-60/9
15	R65280480	1	FERRITE TOROIDALE FT25	FERRITE FT25	FERRITE FT25	FERRIT FT25	FERRITA FT25
16	R65280490	1	FERRITE TOROIDALE FT36	FERRITE FT36	FERRITE FT36	FERRIT FT36	FERRITA FT36
17	R65280240	1	FILTRO FLC470501F	INTERFERENCE SUPPRESSOR	FILTRE ANTIPARASITES	STOERSCHUTZFILTER	FILTRO
18	R69180250	1	FILTRO SCARICO BACINELLA	SUPPRESSOR	FILTRE	FILTER	FILTRO
19	R58003860	1	FLANGIA GUARN.PICCOLA	MOTOR GASKET BRASS FLANGE	BRIDE JOINT MOTEUR	FLANSCH F. MOTORDICHTUNG	BRIDA JUNTA MOTOR
20	R70010030	1	GUARNIZIONE OR 6,07 X 1,78 SILICONE	GASKET OR 6,07 X 1,78	JOINT OR 6,07 X 1,78	RINGDICHTUNG OR 6,07 X 1,78	JUNTA OR 6,07 X 1,78
21	R70010050	1	GUARNIZIONE OR 7,60 X 2,62 OR 3030 NB	GASKET OR 7,60 X 2,62	JOINT OR 7,60 X 2,62	RINGDICHTUNG OR 7,60 X 2,62	JUNTA OR 7,60 X 2,62
22	R70020040	1	GUARNIZIONE MARK IV MLA 1500.02.05	GASKET	JOINT	RINGDICHTUNG	JUNTA
23	R70010210	1	GUARNIZIONE OR NBR 70 18,72x2,62 C.3075	GASKET OR NBR 70 18,72x2,62	JOINT OR NBR 70 18,72x2,62	RINGDICHTUNG OR NBR 70 18,72x2,62	JUNTA OR NBR 70 18,72x2,62
24	R65070230	1	GUARNIZIONE PER TERM. SIC. CAMERM/106-110	GASKET	JOINT	RINGDICHTUNG	JUNTA
25	R70010130	1	GUARNIZIONE SILICONE ROSSO 80x50,3x3	GASKET	JOINT	RINGDICHTUNG	JUNTA
26	R70050150	1	GUARNIZIONE X TAPPO 2" PLAST.G40005	GASKET	JOINT	RINGDICHTUNG	JUNTA
27	R65450200	1	INDUTTANZA 6,5 mH 8A	INDUCTANCE	INDUCTANCE	INDUKTANZ	INDUCTANCIA
28	R65140890	1	INVERTER 0.5KW MOT.INF.A001M005XSB X RIC	INVERTER	INVERSEUR	INVERTER	INVERSOR
29	R62030118	1	MANICOTTO RIDUZ.F.1/8"-1/4 CIL.PRD1222100	1/8"-1/4" FEMALE REDUCTION COUPLING	MANCHON REDUCTION 1/8" - 1/4"	REDUZIERMUFFE 1/8" - 1/4" F	MANGUITO REDUCCION HEMBRA 1/8"-1/4"
30	R70060080	1	MANICOTTO SILICONE D.13X18X80	SILICON SLEEVE	SILICONE SLEEVE	SILIKONHÜLLE	FUNDA DE SILICONA
31	R70060020	1	MANICOTTO SILICONE D.30X35X9 TAPPO SFIA	SILICON SLEEVE	SILICONE SLEEVE	SILIKONHÜLLE	FUNDA DE SILICONA
32	R70060040	2	MANICOTTO SILICONE D.50X50X3	SILICON SLEEVE	SILICONE SLEEVE	SILIKONHÜLLE	FUNDA DE SILICONA
33	R75300020	1	MASCHERINA VENTILATORE D.120 PER VENT.	FAN GUARD GRID D.120	GRILLE VENTILATEUR D.120	VENTILATORSCHUTZGITTER D.120	REJILLA VENTILADOR D.120
34	R75300050	1	MASCHERINA VENTILATORE D.270 N/S071 2014	FAN GUARD GRID D.270	GRILLE VENTILATEUR D.270	VENTILATORSCHUTZGITTER D.270	REJILLA VENTILADOR D.270
35	R65265100	1	MICRO PORTA MAGNETICO COMPLETO RIC.	DOOR SWITCH	MICRO PORTE	TUERSCHALTER	MICRO PUERTA
36	R65220280	1	MORSETTIERA MONOFASE C/TERRA PAS-SANTE	TERMINAL BOARD	BORNIER	KLEMMLEISTE	REGLETERA

**ATTENZIONE:** PER ORDINARE I RICAMBI, SPECIFICARE SEMPRE IL MODELLO DI FORNO ED IL NUMERO DI MATRICOLA  
**ATTENTION:** WHEN ORDERING SPARE PARTS, PLEASE ALWAYS SPECIFY THE OVEN MODEL AND THE SERIAL NUMBER

**ATTENTION:** POUR COMMANDER DES PIÈCES, MERCI DE SPECIFIER TOUJOURS LE MODÈLE DU FOUR ET LE NUMÉRO DE SÉRIE  
**ACHTUNG:** UM ERSATZTEILE ZU BESTELLEN, BITTE IMMER OFEN-MODELL UND SERIENNUMMER GEBEN.

ed. 0914

POS.	COD.	Pz.	DESCRIZIONE	DESCRIPTION	DESCRIPTION	BESCHREIBUNG	DESCRIPCIÓN
37	R65040600	1	MOTORE KW025 F3 2P 220/240V 1057	MOTOR	MOTEUR	MOTOR	MOTOR
38	R69010260	1	NASELLO 1 STEP 6303-020022	DOOR LATCH 1 STEP	GACHE DE PORTE POUR OUVERTURE SIMPLE	SCHLISSNASE 1 STUFE	NARIZ 1 CIERRE
39	R63060160	1	PANNELLO ACCENS. S4565C1116B Ts=5 Tps=1	BURNER IGNITION PANEL	ALLUMEUR GAZ	ZUENDBOX	PANEL DE ENCENDIDO
40	R58006690	1	TAPPO SFIATO COMPLETO SERIE 2014	COVER	BOUCHON	ABDECKUNG	TAPON
41	R58003140	2	PERNO AGGANCIAMENTO DEFLETTORE	FAN GUARD PANEL PIN	PIVOT DEFLECTEUR	BOLZEN FÜR LUFTLEITBLECH	PERNO CIERRE DEFLECTOR
42	R58003110	2	PERNO FISSAGGIO DEFLETTORE	FAN GUARD PANEL PIN	PIVOT DEFLECTEUR	BOLZEN FÜR LUFTLEITBLECH	PERNO CIERRE DEFLECTOR
43	R58002670	1	PERNO INF.CERNIERA REG.C/FERMI SR.2005	LOWER HINGE PIN	CHEVILLE CHARNIERE INFERIEURE	UNTERES SIE SCHARNIERSTIFT	PERNO INFERIOR BISAGRA
44	R58000370	1	PERNO SUP.CERNIERA REG. N/S 2014	UPPER HINGE PIN	CHEVILLE CHARNIERE SUPERIEURE	OBERES SCHARNIERSTIFT	PERNO SUPERIOR BISAGRA
45	R65210020	6	PORTAFUSIBILE BARRA DIN 5x20	FUSE CARRIER	PORTE-FUSIBLE	SICHERUNGSHALTER	PORTAFUSIBILE
46	R65240010	1	PRESSACAVO PG 107 Z/16	FAIRLEAD	PRESSE CABLE	ZUGENTLASTUNG	PRENSACABLES
47	R63070050	1	PRESSOSTATO 1/8" 0,5-0,35 BAR PH/91140	WATER SAFETY PRESSURE SWITCH	INT.A PRESSION SEC.-EAU	WASSER-DRUCKWACHTER	PRESOSTATO AQUA
48	R63070010	1	PRESSOSTATO PG 901.61	GAS SAFETY PRESSURE SWITCH	INT.A PRESSION SECURITE-GAZ	DRUCKSCHALTER PG	PRESOSTATO GAS
49	R65090220	1	PROGRAMMAT. 1 CAMME V220/50HZ 1 CIRCUITO	DAMPER SYSTEM	SORTIE EVAPORATION MOUFLE	DAMPFABLASS-STELLMOTOR	MOTOR RESPIRADERO COMPLETO
50	R62090478	2	RACC. INTERMEDIO A GOMITO D.10 PM0310E	ELBOW PIPE FITTING	COURBE AVEC QUEUE	STUCK MIT SCHAFT	RACOR CON CODO
51	R62090508	2	RACC.TERMIN.DIR.FIL.CON.10X1/4 PM011002E	10X1/4 STRAIGHT THREADED TERMINAL PIPE FITTING	RACCORDEMENT	ENDVERBINDUNGSSTUCK 10 X 1/4" GESCHNITTEN	RACOR
52	R62090633	1	RACCORDO OTTONE CURVO 10/10 C/ OGIVA	ELBOW PIPE FITTING BRASS D.10	RACCORDEMENT A COUDE LAITON D 10	WINKELSTUTZEN AUS MESSING D.10	RACOR LATON DE GOMA D.10
53	R65110510	1	REGOL. PORTATA ROSSO ALPHATECH. 15LT/H	15 LT/H WATER FLOW REDUCER	REGULATUER DE DEBIT 15 LT.	DURCHFLUSSMONDERER 15 L/STD.	REGULADOR DE CAUDAL 15 LT.
54	R69180120	1	SCATOLA COND.SCARICO G/MV T06-T10-T21	QUENCHING-DRAIN COLLECTOR	BOITE DE CONDENSATION DECHARGE	KONDENSATION-ABFLUSS SCHACHTEL	CAJON CONDENSACION-DESAGÜE
55	R65320220	2	SONDA "K" 6X80 1,5ML. TESTA RASTREM.20mm	PROBE "K" 6X80 1,5ML.	SONDE "K" 6X80 1,5ML.	FUEHLER "K" 6X80 1,5ML.	SONDA "K" 6X80 1,5ML.
56	R69150100	1	TAPPO FEMMINA G 2" PP+25%FV NERO	COVER	BOUCHON	ABDECKUNG	TAPON
57	R65140380	1	TELERUTTORE 3RT1016-1AP02	CONTACTOR	CONTACTEUR	SCHUETZ	CONTACTOR
58	R62090868	1	TERMINALE CIECO D.10 PSE4610W	PIPE FITTING	COURBE	STUCK	RACOR
59	R65070350	1	TERMOSTATO SICUR. 360°C -25K 55.32572.8	THERMOSTAT	THERMOSTAT	THERMOSTAT	TERMOSTATO
60	R65180420	3	TRASF.RE 20VA 0-220-240/12V MOD.163.16	TRANSFORMER	TRANSFORMATEUR	TRANSFORMATOR	TRANSFORMADOR
61	R80150000	1	TUBO PE 10 mm x7 AZZURRO PM950612E	BLUE PIPE	TUBE	LEITUNG	TUBO
62	R58006160	2	UGELLO COND.D.0,8 CODOLO CIL.10	NOZZLE	BEC	DÜSE	BOQUILLA
63	R65060050	2	VENTILATORE COMPATTO D.120 4715MS 23T	COMPONENTS VENTILATION MOTOR	MOTEUR DE REFROIDISSEMENT	ABKÜHLUNGS MOTOR	MOTOR DE ENFRIAMIENTO
64	R75400570	1	VENTOLA D.240X80/6 P.D. 50HZ . K_081 T07	FAN	TURBINE	LUEFTERRAD	PALA VENTILADOR
65	R61260152	2	VITE TCB+A2 M 4X10	SCREW TCB+A2 M 4X10	VIS TCB+A2 M 4X10	SCHRAUBE TCB+A2 M 4X10	TORNILLO TCB+A2 M 4X10
66	R62200028	1	LANCIA DI LAVAGGIO SENZA TUBO	SHOWER HANDLE	POIGNEE DOUCHETTE	GRIFF F. HANDBRAUSE	MANGO DUCHA
67	R62200058	1	GOMMA 1/2"x1/2"x2.5M	FLEXIBLE PIPE SHOWER	TUBE FLEXIBLE DOUCHETTE	SCHEAUCH FUER HANDBRAUSE	TUBO FLEXIBLE DUCHA
68	R70030040	2	GUARNIZIONE D.16X24 3/4 GOMMA	GASKET D.16X24 3/4	JOINT D.16X24 3/4	DICHTUNG D.16X24 3/4	JUNTA D.16X24 3/4
69	R70030030	1	GUARNIZIONE D.11X19 1/2" GOMMA	GASKET D. 11X19 1/2"	JOINT D. 11X19 1/2"	DICHTUNG D. 11X19 1/2"	JUNTA D. 11X19 1/2"
70	R69180300	1	SUPPORTO IN PLASTICA PER DOCCIONE ESTERNO	HOLDER	SUPPORT	HALTERUNG	SOPORTE
71	R62090918	1	RACC.INT.A GOMITO D.10 SPEEDFIT PEM0310W	WHITE ELBOW PIPE FITTING D.10	COURBE AVEC QUEUE	STUCK MIT SCHAFT	RACOR CON CODO
72	R80150060	0,9m	TUBO PEX-B 10MM ROTOLO 100MT 10BPEX- 100C	WHITE PIPE	TUBE	LEITUNG	TUBO
73	R58000360	1	DADO PER PERNO CERNIERA REG. N/S 2014	NUT FOR UPPER DOOR HINGE	ECROU CHEVILLE CHARNIERE SUPERIEURE	MUTTER F. OBERES SCHARNIERSTIFT	TUERCA PARA PERNO BISAGRA SUPERIOR
74	R80120030	0,1m	TUBO SILICONE ROSSO SR60 18/13.	RED PIPE	TUBE ROUGE	ROTEN LEITUNG	TUBO ROJO
75	R80120060	1,5m	TUBO SILIC. TRASP.SR60/TR 7/12.	PIPE	TUBE	LEITUNG	TUBO

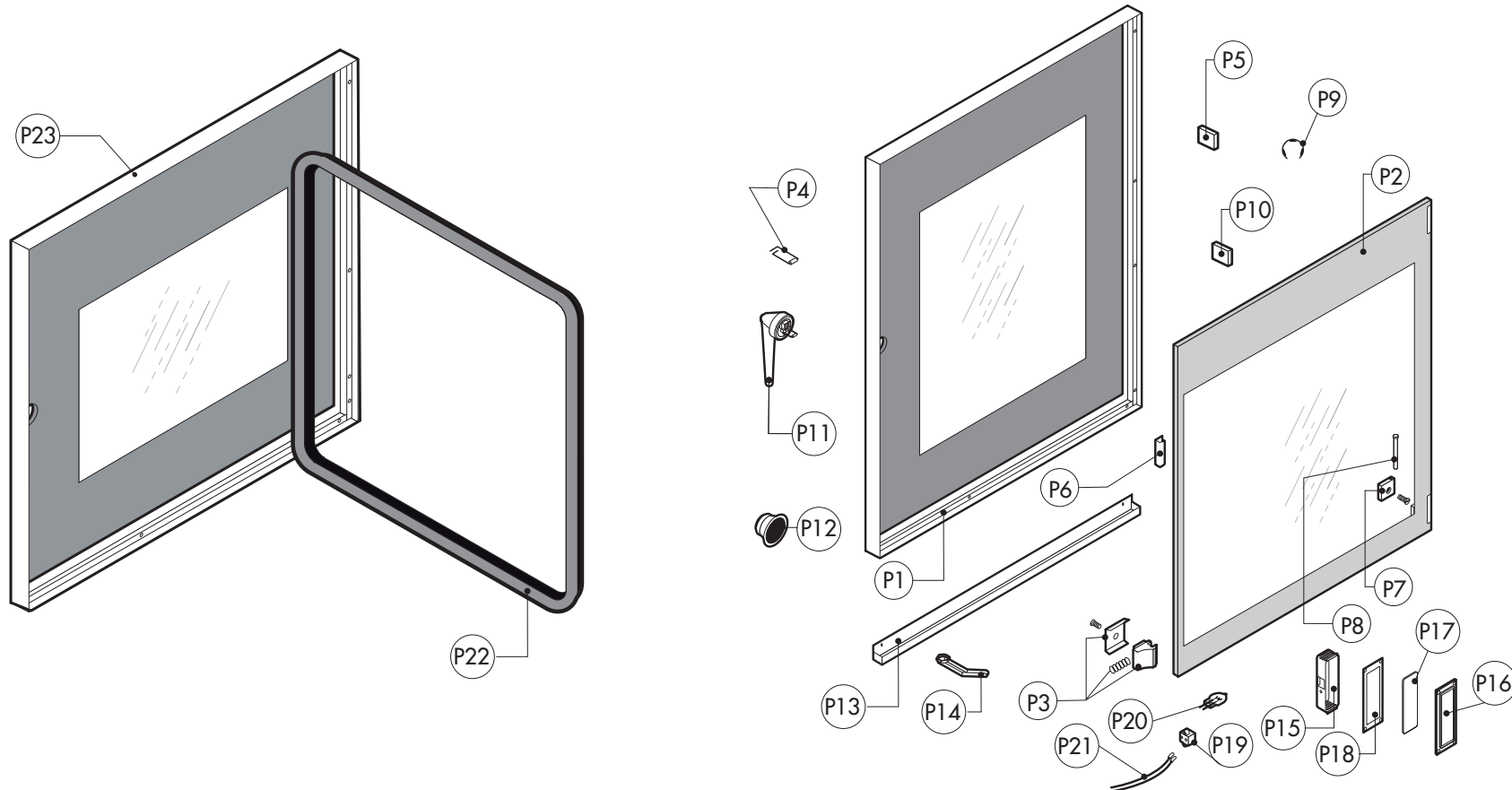



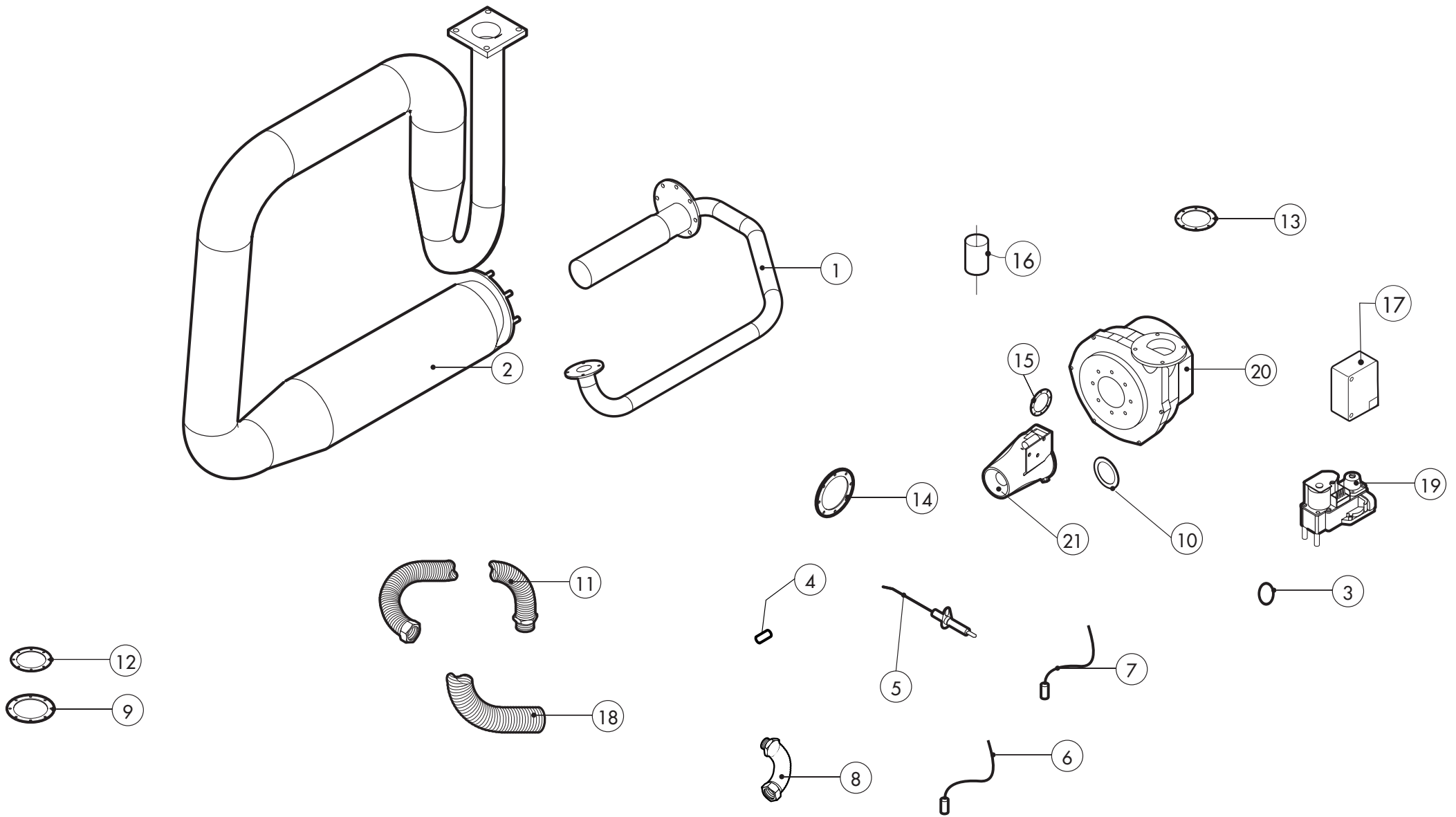

**ATTENZIONE:** PER ORDINARE I RICAMBI, SPECIFICARE SEMPRE IL MODELLO DI FORNO ED IL NUMERO DI MATRICOLA  
**ATTENTION:** WHEN ORDERING SPARE PARTS, PLEASE ALWAYS SPECIFY THE OVEN MODEL AND THE SERIAL NUMBER

**ATTENTION:** POUR COMMANDER DES PIÉCES, MERCI DE SPECIFIER TOUJOURS LE MODELE DU FOUR ET LE NUMERO DE SERIE  
**ACHTUNG:** UM ERSATZTEILE ZU BESTELLEN, BITTE IMMER OFEN-MODELL UND SERIENNUMMER GEBEN.

ed. 0914

POS.	COD.	Pz.	DESCRIZIONE	DESCRIPTION	DESCRIPTION	BESCHREIBUNG	DESCRIPCIÓN
1	R14216580	1	ASS.BRUCIATORE CAMERA T07 2011	COOKING CABINET BURNER	BRÛLEUR MOUFLE	GARRAUMBRENNER	QUEMADOR CAMERA
2	R14216650	1	ASS.SCAMBIATORE CAMERA T07 2011	HEAT EXCHANGER ACCESSORIES INCLUDED	ECHANGEUR CHALEUR ET ACCESSOIRES	WÄRMETAUSCHER KOMPLETT MIT ZUBEHÖR	INTERCAMBIADOR COMPLETO CON ACCESORIOS
3	R62070023	1	BICONO PILOTA TUBO D.6 905.	BICONE D.6	BICONE D. 6	KEGEL D.6	BICONO D.6
4	R58001480	3	BOCCOLA FISSAGGIO CANDELETTE	BUSH	DOUILLE	BUSCH	CASQUILLO
5	R63050130	3	CANDELA ACCENSIONE A/SM ø9.5 KA1 ø3/M4	IGNITOR	BOUGIE ALLUMAGE	ZUENDKERZE	BUJIA ENCENDIDO
6	R66605801	1	CAVO ACC./RIL.CAM./BOIL. L=700 2 CAVI	FLAME IGNITION CABLE/FLAME SENSOR CABLE	CABLE ALLUMAGE/CONTROLE FLAME	ZUENDKABEL/FLAMMENUEBERWACHUNGSKABEL	CABLE ENCENDIDO/SENSOR
7	R66605120	1	CAVO ACCENS.C/CONNETT.A 90° D.6,3 L=800	FLAME IGNITION CABLE/FLAME SENSOR CABLE	CABLE ALLUMAGE/CONTROLE FLAME	ZUENDKABEL/FLAMMENUEBERWACHUNGSKABEL	CABLE ENCENDIDO/SENSOR
8	R62280078	1	CURVA POLYPR.HTB DN50 87,5° DIN EN1451-1	CURVE	COURBE	KURVE	CURVA
9	R11425700	1	DIAFRAMMA VENTILATORE/BRUCIATORE D.14	ORIFICE D.14	DIAPHRAGME D.14	BLLENDE D.14	DIAFRAGMA D.14
10	R58004170	1	DISCO CALIBRATO ø3 mm	ORIFICE ø3 mm	DIAPHRAGME ø3 mm	BLLENDE ø3 mm	DIAFRAGMA ø3 mm
11	R62180132	1	FLEX GAS L=50 CM M/F1/2" INOX	GAS INLET FLEXIBLE PIPE	TUBE FLEXIBLE ENTREE GAZ	FLEXROHR GASZULAUF	TUBO FLEXIBLE ENTRADA GAS
12	R63140010	2	GUARN.BOIL.-COND.FUMI VM-G/061.	BURNER/FAN MOTOR GASKET	JOINT VENTILATEUR / BRULEUR	DICHTUNG GEBLASE/GASBRENNER	JUNTA VENTILADOR/QUEMADOR
13	R63140050	2	GUARN.VENTILATORE-BRUCIATORE	BURNER/FAN MOTOR GASKET	JOINT VENTILATEUR / BRULEUR	DICHTUNG GEBLASE/GASBRENNER	JUNTA VENTILADOR/QUEMADOR
14	R63140070	2	GUARNIZIONE SCAMB.-BRUC. De.84 9kW	BURNER/HEAT EXCHANGER GASKET	JOINT BRULEUR / ECHANGEUR CALORIFIQUE	DICHTUNG BRENNER/WARMETAUSCHER	JUNTA QUEMADOR/INTERCAMBIADOR
15	R70050090	1	GUARNIZIONE VALVOLA VENTURI INGRESSO LAT	VENTURI GASKET	JOINT VENTURI	DICHTUNG	JUNTA VENTURI
16	R70060121	1	MANICOTTO RIDUZIONE De.45,5 Di.35 (PA 6)	REDUCTION COUPLING	MANCHON REDUCTION	REDUZIERMUFFE	MANGUITO REDUCCION
17	R65180270	1	TRASF.ACCENS. COFI TRK2-3PVD	IGNITION TRANSFORMER	TRANSFORMATEUR D'ALLUMAGE	ZÜNDTRANSFORMATOR	TRANSFORMADOR DE ENCENDIDO DESDE
18	R77700056	0,5m	TUBO FLEX c/Spirale Di.30 De.35,3 COMAP	AIR INLET FLEXIBLE PIPE	TUBE ASPIRATION AIR	LUFTANSAUGRUHR	TUBO ASPIRACION AIRE
19	R63020170	1	VALVOLA GAS VK4115 V 1014 HON.	GAS SOLENOID VALVE	VALVE GAZ	GAS VENTIL	VALVULA GAS
20	R65060360	1	VENTILATORE RG128/1300-3612-020203	GAS BURNER FAN MOTOR	VENTILATEUR POUR BRULEUR GAZ	GEBLASEF.GASBRENNER	VENTILADOR PARA QUEMADOR GAS
21	R63120020	1	VENTURI VAL.GAS.BRUC.PREMIX45900446-055B	VENTURI TUBE	VENTURI	VENTURIROHR	VENTURI

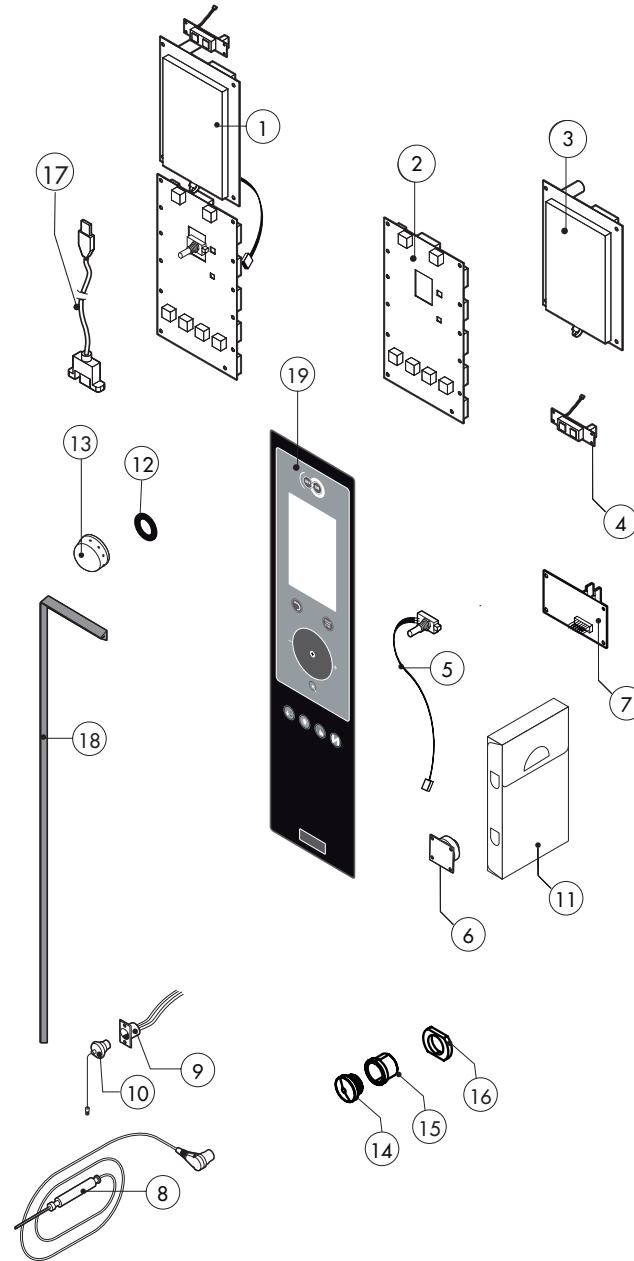



POS.	COD.	Pz.	DESCRIZIONE	DESCRIPTION	DESCRIPTION	BESCHREIBUNG	DESCRIPCIÓN
1	R65301900	1	SCHEDA "X" 2006 COMPLETA	CONTROL PANEL PC BOARD "X"	PLATINE ÉLECTRONIQUE COMPLÈTE "X"	STEUERPLATINE KOMPLETT "X"	PLACA COMPLETA "X"
2	R65301910	1	SCHEDA BASE POTENZA TOP LCD "X" Sr.2006	MAIN PC BOARD "X"	FICHE PANNEAU PRINCIPAL "X"	HAUPTPLATINE "X"	PLACA BASE "X"
3	R65301920	1	SCHEDA DISPLAY TOP LCD "X" Sr.2006	DISPLAY PC BOARD "X"	PLATINE ÉLECTRONIQUE DISPLAY "X"	DISPLAYPLATINE "X"	PLACA DISPLAY "X"
4	R65301930	1	SCHEDA ON-OFF TOP LCD "X" Sr.2006	ON-OFF BOARD "X"	ON-OFF PANNEAU "X"	ON-OFF PLATINE "X"	ON-OFF PLACA "X"
5	R65301940	1	ENCODER LCD "X" SR.2006	FRONT PC BOARD ENCODER	ENCODER PLATINE	ENCODER F. PLATINE	ENCODER PLACA ELECTRONICA
6	R65301960	1	SCHEDA BUZZER TOP LCD "X" Sr.2006	PC BOARD BUZZER	SONNERIE PLATINE	PLATINENSUMMER	ZUMBADOR PLACA ELECTRONICA
7	R65301950	1	SCHEDA ESPANSIONE BRUCIATORI "X" Sr.2006	BOILER CONTROL PC BOARD	FICHE ELECTRON. CONTROLE CHAUDIERE	ESPANSIONSPLATINE	PLACA EXPANSION
8	R65321102	1	SONDA AL CUORE K 4 PUNTI 6 PIN.IMP.2012	CORE TEMPERATURE PROBE	SONDE A COEUR	KERNTEMPERATURFUEHLER	SONDA AL CORAZON
9	R65321110	1	CONNETTORE FEMM. S/CUORE 6 PIN	CORE TEMPERATURE PROBE FEMALE CONNECTOR	CONNECTEUR FEMELLE POUR SONDE A COUER	STECKDOSE F. KERNTEMPERATURFUEHLER	CONECTOR HEMBRA PARA SONDA AL CORAZON
10	R65321020	1	TAPPO X CONNETTORE 4 PIN.	COVER FOR CONNECTOR	BOUCHON POUR CONNECTEUR	ABDECKUNG STECKDOSE	TAPON PARA CONECTOR
11	R86020400	1	VALIGETTA X SONDA AL CUORE TRASPARENTE	CORE TEMPERATURE PROBE BOX	PETITE VALISE SONDE A COEUR	TASCHE F. KERNTEMPERATURFUEHLER	ESTUCHE DE SONDA AL CORAZON
12	R70010250	1	GUARNIZIONE OR 17,17 X 1,78 NBR-70	JOINT OR 17,17 X 1,78	OR GASKETS 17,17 X 1,78	RINGDICHTUNG OR 17,17 X 1,78	JUNTA OR 17,17 X 1,78
13	R69030250	1	MANOPOLA ENCODER D.60	KNOB KIT	POIGNEE COMMANDE	DREHKNOFF	PULSADOR MANETA
14	R65321290	1	ASS.TAPPO PER PRESA USB 2012	COVER	BOUCHON	ABDECKUNG	TAPON
15	R65321250	1	BOCCOLA PER PRESA USB 2012	BUSH	DOUILLE	BUSCH	CASQUILLO
16	R58004380	1	DADO PER PRESA USB 2012	NUT	ECROU	MUTTER	TUERCA
17	R65010350	1	CAVO COLL. SCHEDA/PRESA USB HEART L=750	PC BOARD CONNECTION USB	CABLE USB POUR LA PLATINE	REIHENKABLE USB FÜR PLATINEVERBINDUNG	CABLE USB CONEXIÓN FICHA
18	R80100100	1 m	GUARNIZIONE CRUSCOTTO	GASKETS	JOINT	RINGDICHTUNG	JUNTA
19		1	TASTIERA	PLATE	PLAQUE	BEDIENUNGSFOLIE	TARJETA

**ATTENZIONE:** PER TENSIONI SPECIALI, SPECIFICARE SEMPRE IL MODELLO DI FORNO ED IL NUMERO DI MATRICOLA  
**ATTENTION:** FOR SPECIAL VOLTAGES, PLEASE ALWAYS SPECIFY THE OVEN MODEL AND THE SERIAL NUMBER

**ATTENTION:** POUR TENSIONS SPÉCIALES, MERCI DE SPÉCIFIER TOUJOURS LE MODÈLE DU FOUR ET LE NUMÉRO DE SÉRIE  
**ACHTUNG:** BEI SONDRSPANNUNGEN, BITTE IMMER OFEN-MODELL UND SERIENNUMMER GEBEN.

ed. 0914

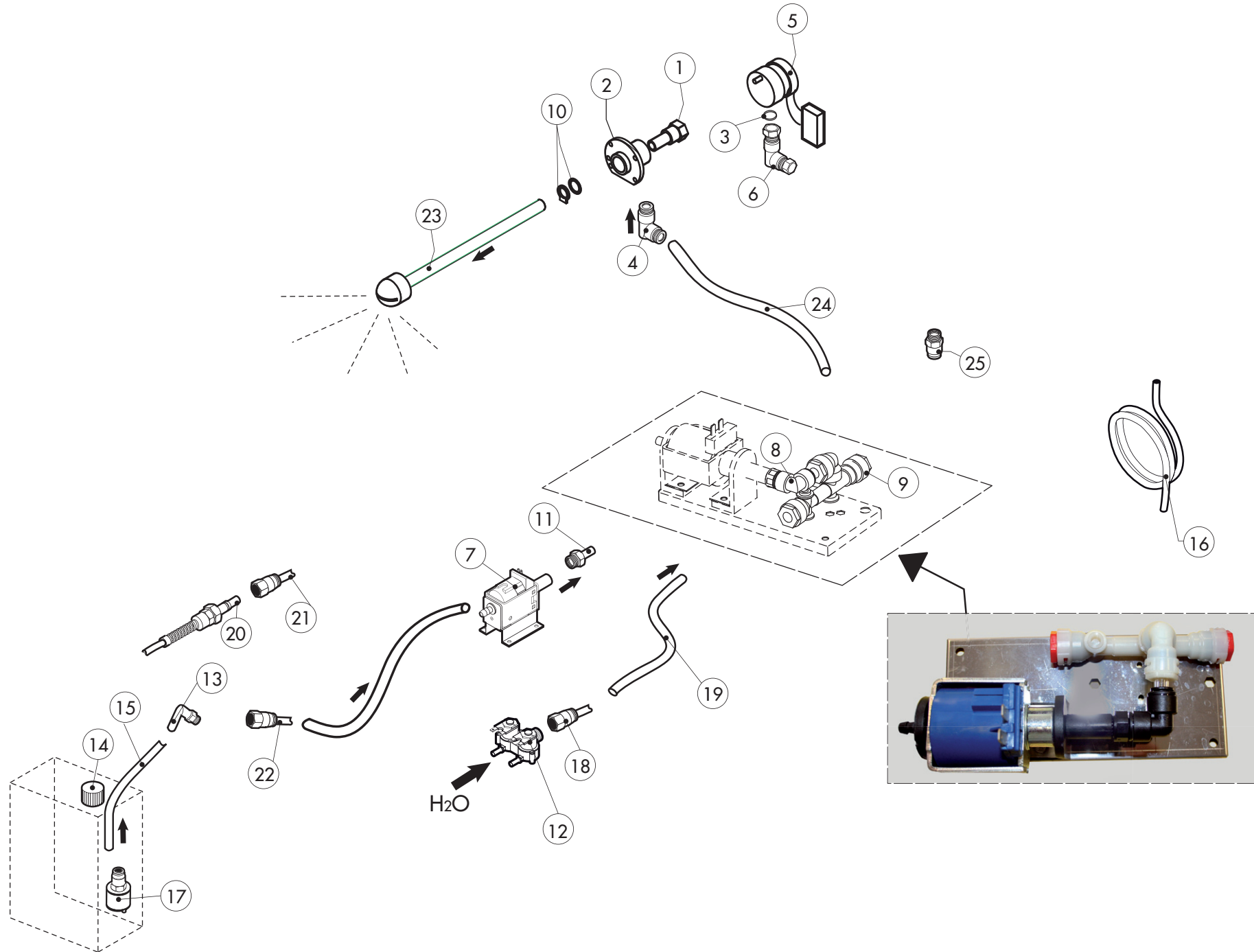

**ATTENZIONE:** PER ORDINARE I RICAMBI, SPECIFICARE SEMPRE IL MODELLO DI FORNO ED IL NUMERO DI MATRICOLA  
**ATTENTION:** WHEN ORDERING SPARE PARTS, PLEASE ALWAYS SPECIFY THE OVEN MODEL AND THE SERIAL NUMBER

**ATTENTION:** POUR COMMANDER DES PIÉCES, MERCI DE SPECIFIER TOUJOURS LE MODELE DU FOUR ET LE NUMERO DE SERIE  
**ACHTUNG:** UM ERSATZTEILE ZU BESTELLEN, BITTE IMMER OFEN-MODELL UND SERIENNUMMER GEBEN.

ed. 0914

POS.	COD.	Pz.	DESCRIZIONE	DESCRIPTION	DESCRIPTION	BESCHREIBUNG	DESCRIPCIÓN
1	R58007000	1	PERNO ROTANTE LAVAGGIO MOB	ROTATING PIVOT	PIVOT TOURNANT	UMLAUFENDE STÜTZE	GOZNE ROTATORIO
2	R58007020	1	FLANGIA LAVAGGIO MOB	WASHING SYSTEM FLANGE	BRIDE BRAS DE LAVAGE	FLANSCH WASCHARMBEFESTIGUNG	PLATINA LAVADO
3	R70010080	1	GUARNIZIONE OR 14x2 Viton DIN 981	GASKETS	JOINT	RINGDICHTUNG	JUNTA
4	R62090663	1	RACCORDO OTTONE NICH.A L C/OGIVA 10x1/4"	ELBOW PIPE FITTING BRASS D.10x1/4"	RACCORDEMENT A COUDE LAITON D 10x1/4"	ELBOW PIPE FITTING BRASS D.10x1/4"	RACOR LATON DE GOMA D.10x1/4"
5	R65090260	1	MOTORIZ. LAV. METEOR (58U59DB4A1-00)	WASHING GEARED MOTORS	MOTO-REDUCTEURS DE LAVAGE	GETRIEBEMOTOREN	MOTORREDUCTORES LAVADO
6	R62090633	1	RACCORDO OTTONE CURVO 10/10 C/OGIVA	ELBOW PIPE FITTING BRASS D.10	RACCORDEMENT A COUDE LAITON D 10	WINKELSTUTZEN AUS MESSING D.10	RACOR LATON DE GOMA D.10
7	R65110600	1	POMPA ELETTRIC. A PIS. OSC. ET508LAB 2273	POMPE DETERGEANT	DETERGENT PUMP	REINIGERPUMPE	BOMBA DETERGENTE
8	R62090498	1	RACC. INTERMEDIO A GOMITO D.8 PM0308E	ELBOW PIPE FITTING F	COURBE AVEC QUEUE	WINKELVERBINDUNGSSTÜCK	RACOR DE GOMA
9	R62090888	1	COLLET. RES. ACET. 3VIE- 2D.10+1D.8 + 2 ANTIRIT	MANIFOLD	COLLECTEUR	KRÜMMER	COLECTOR
10	R70045120	1	KIT GUARNIZIONI X LAVAGGIO MOB	GASKETS KIT	ENSEMBLE JOINTS	DICHTUNGSSATZ	KIT JUNTAS
11	R62090608	2	TERMINALE C/CODOLO 8x1/8" PM05081E	8X1/8 END SIDE PIPE FITTING (WITH TANG)	RACCORD AVEC QUEUE 8x1/8"	ENDVERBINDUNGSSTÜCK 8 X 1/8" MIT SCHAFT	RACOR TERMINAL CON CODO 8x1/8"
12	R65110210	1	E.V. 2 VIE 220V 50HZ X J.G. CON ATTACC FINO ALLA SETTIMANA 10/2015	SOLENOID VALVE 2 VIE 220V 50HZ UNTIL WEEK 10/2015	ELECTROVANNE 2 VIE 220V 50HZ ELIMINE DU SEMAINE 10/2015	MAGNETVENTIL 2 VIE 220V 50HZ BIS WOCHEN 10/2015	ELECTROVALVULA 2 VIE 220V 50HZ ELIMINATO DEL SEMANA 10/2015
12	R65110330	1	E.V. 2 VIE 230V 50/60HZ OUT J.G. D.10 DALLA SETTIMANA 10/2015	SOLENOID VALVE 2 VIE 230V 50/60HZ OUT J.G. D.10 SINCE WEEK 10/2015	ELECTROVANNE 2 VIE 230V 50/60HZ OUT J.G. D.10 DU SEMAINE 10/2015	MAGNETVENTIL 2 VIE 230V 50/60HZ OUT J.G. D.10 VOM WOCHEN 10/2015	ELECTROVALVULA 2 VIE 230V 50/60HZ OUT J.G. D.10 DEL SEMANA 10/2015
13	R62090678	1	RACC. A GOMITO C/CODOLO 8X8 PM220808E	ELBOW PIPE FITTING (WITH TANG) 8 X 8	COURBE AVEC QUEUE 8x8	WINKELVERBINDUNGSSTÜCK 8X8 MIT SCHAFT	RACOR DE GOMA CON CODO 8x8
14	R58005060	1	TAPPO TANICA GIALLO x LAVAGGIO	COVER	BOUCHON	ABDECKUNG	TAPON
15	R80150020	2 m	TUBO DETERGENTE PE D.8mm x 6	PE D.8mm x6 DETERGENT FLEXIBLE PIPE	TUBE DETERGEANT D. 8x6	ROHRLEITUNG F. REINIGER PE D.8mm x6	TUBO DETERGENTE PE D.8mm X 6
16	R70070080	1m	TUBO CARICO ACQUA D.23mm x13	PIPE	TUBE	LEITUNG	TUBO
17	R65110650	1	VALVOLA DI FONDO PER FILTRO GM.060.35	BOTTOM FILTER	FILTER POUR TUBE DETERGEANT	ANSAUGFILTER F. REINIGUNGSSCHAUCH	VÁLVULA DE FONDO TUBO DEL LIMPIADOR
18	R62020118	1	NIPPLES MASCHIO CONICO 1/4" PNID020200	STRAIGHT THREADED TERMINAL PIPE FITTING	RACCORD FILETE DROIT	ENDVERBINDUNGSSTÜCK GESCHNITTEN	RACOR TERMINAL DERECHO ROSCADO
19	R80120060	1m	TUBO SILIC. TRASP.SR60/TR 7/12.	PIPE	TUBE	LEITUNG	TUBO
20	R62090482	1	RACC. RAPIDO MASCHIO X LAVAG. PIPU40-C08M	RAPID MALE PIPE FITTING	RACCORD RAPIDE PARTIE MALE	SCHNELLVERBINDUNG MANNL	RACOR RAPIDO MACHO
21	R62090638	1	RACC. RAP. FEMM. X LAV. FIL. FEMM PVPJ40-F1/4	RAPID FEMALE PIPE FITTING	RACCORD RAPIDE PARTIE FEMELLE	SCHNELLVERBINDUNG	RACOR RAPIDO HEMBRA
22	R62090538	1	RACC. DIR. F. 1/4" TUBO 6X8 A CALZ. PRCF220008	1/4" FEMALE STRAIGHT PIPE FITTING FOR D.6X8 PIPE	RACCORD DROIT PARTIE FEMELLE 1/4" TUBE 6x8	VERBINDUNGSSTÜCK 1/4" WEBL. FÜR ROHR D.6x8	RACOR DERECHO HEMBRA 1/4" PARA TUBO D.6x8
23	R58007040	1	TESTA LAVAGGIO MOB+ALBERO L=120 (071/T06)	WASHING SYSTEM INNER ASSEMBLY	ENSEMBLE INTERIEUR DU LAVAGE	INNEN WASCHARMBEFESTIGUNG	KIT INTERNO LAVADO
24	R80150000	1	TUBO PE D.10mm x 7 AZZURRO	PE D.10mm x7 WATER FLEXIBLE PIPE	TUBE FLEXIBLE EAU D. 10x7	WASSERFLEXROHRLEITUNG PE D.10 mm x7	TUBO FLEXIBLE AGUA PE D.10mm X 7
25	R62090688	1	RACC. TERMIN. DIR. FIL. CON. 8X1/4 NC2500-P	8x1/4 STRAIGHT THREADED TERMINAL PIPE FITTING	RACCORD FILETE DROIT 8x1/4"	ENDVERBINDUNGSSTÜCK 8x1/4" GESCHNITTEN	RACOR TERMINAL DERECHO ROSCADO 8x1/4"