

**ATTENZIONE:** PER TENSIONI SPECIALI, SPECIFICARE SEMPRE IL MODELLO DI FORNO ED IL NUMERO DI MATRICOLA  
**ATTENTION:** FOR SPECIAL VOLTAGES, PLEASE ALWAYS SPECIFY THE OVEN MODEL AND THE SERIAL NUMBER

**ATTENTION:** POUR TENSIONS SPÉCIALES, MERCI DE SPÉCIFIER TOUJOURS LE MODÈLE DU FOUR ET LE NUMÉRO DE SÉRIE  
**ACHTUNG:** BEI SONDRERSPANNUNGEN, BITTE IMMER OFEN-MODELL UND SERIENNUMMER GEBEN.

ed. 0713

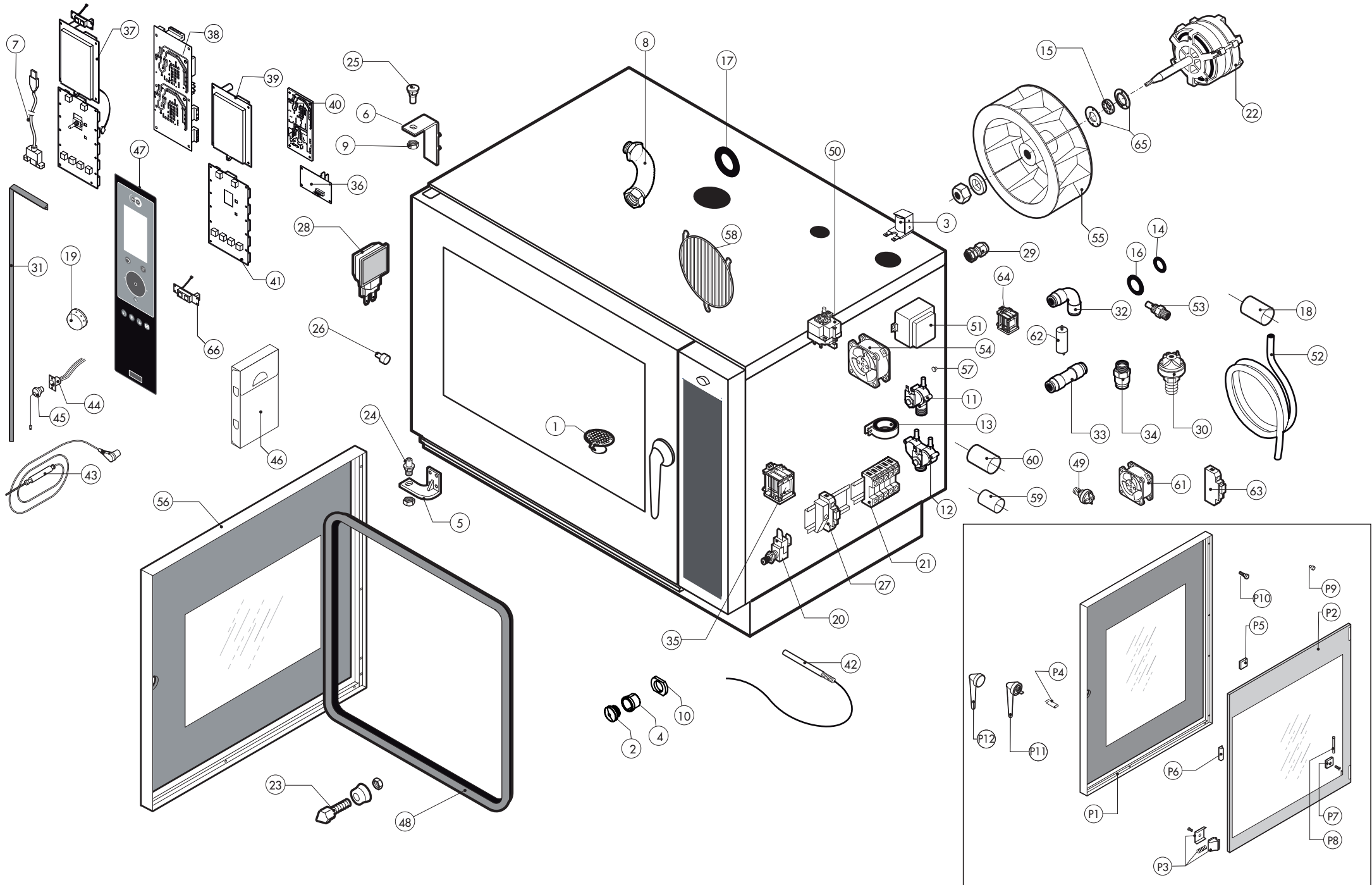

**TAV. A**

**CVG 051 X**

**ATTENZIONE:** PER ORDINARE I RICAMBI, SPECIFICARE SEMPRE IL MODELLO DI FORNO ED IL NUMERO DI MATRICOLA  
**ATTENTION:** WHEN ORDERING SPARE PARTS, PLEASE ALWAYS SPECIFY THE OVEN MODEL AND THE SERIAL NUMBER

**ATTENTION:** POUR COMMANDER DES PIÈCES, MERCI DE SPECIFIER TOUJOURS LE MODÈLE DU FOUR ET LE NUMÉRO DE SÉRIE  
**ACHTUNG:** UM ERSATZTEILE ZU BESTELLEN, BITTE IMMER OFEN-MODELL UND SERIENNUMMER GEBEN.

ed. 0713

POS.	COD.	Pz.	DESCRIZIONE	DESCRIPTION	DESCRIPTION	BESCHREIBUNG	DESCRIPCIÓN
1	R10201700	1	ASS.FILTRO DI SCARICO D.76/44.5 M/106-11	DRAIN FILTER	FILTRE ENCEINTE	ABFLUSSFILTER	FILTRO DESAGUE
2	R65321290	1	ASS.TAPPO PER PRESA USB 2012	COVER	BOUCHON	ABDECKUNG	TAPON
3	R65090300	1	ATTUATORE (G01002230V)	MAGNETIC SPOOL	BOBINE MAGNÉTIQUE	MAGNETISCHE SPULE	BOBINA MAGNÉTICA
4	R65321250	1	BOCCOLA PER PRESA USB 2012	BUSH	DOUILLE	BUSCH	CASQUILLO
5	R18421580	1	CERNIERA INFERIORE PORTA E_042-051	LOWER DOOR HINGE	CHARNIERE INFERIEURE PORTE	UNTERES SCHARNIER	BISAGRA INFERIOR
6	R18421570	1	CERNIERA SUPERIORE PORTA E_042-051	UPPER DOOR HINGE	CHARNIERE SUPERIEURE PORTE	OBERES SCHARNIER	BISAGRA SUPERIOR
7	R65010350	1	CAVO COLL. SCHEDA/PRESA USB HEART L=750	PC BOARD CONNECETION USB	CABLE USB POUR LA PLATINE	REIHENKABLE USB FÜR PLATINEVERBINDUNG	CABLE USB CONEXIÓN FICHA
8	R62280038	1	CURVA C/MORSET.HTS-HTSW X TUBO D.50	CURVE WITH TERMINAL	COURBE AVEC BORNIER	KURVE MIT KLEMM	CURVA CON REGLETERA
9	R58004050	2	DADO PER PERNO CERNIERA REG. M/106-220	NUT FOR UPPER DOOR HINGE	ECROU CHEVILLE CHARNIERE SUPERIEURE	MUTTER F. OBERES SCHARNIERSTIFT	TUERCA PARA PERNO BISAGRA SUPERIOR
10	R58004380	1	DADO PER PRESA USB 2012	NUT	ECROU	MUTTER	TUERCA
11	R65110200	1	E.V. 1 VIA 220V 50HZ X J.G.CON ATTACC	SOLENOID VALVE	ELECTROVANNE	MAGNETVENTIL	ELECTROVALVULA
12	R65110230	1	E.V. 2VIE 1P+1D 220V/50HZ J.G.CON ATTACC	SOLENOID VALVE 220V 50HZ	ELECTROVANNE 220V 50HZ	MAGNETVENTIL 220V 50HZ	ELECTROVALVULA 220V 50HZ
13	R65280490	1	FERRITE TOROIDALE FT36	FERRITE	FERRITE	FERRIT	FERRITA
14	R70010050	1	GUARNIZIONE OR 7,60 X 2,62 OR 3030 NB	JOINT OR 7,60x2,62	OR GASKETS	RINGDICHTUNG 7,60x2,62	JUNTA OR 7,60x2,62
15	R70020020	1	GUARNIZIONE DI TENUTA A 04 BAD40 8X22	JOINT	GASKETS	RINGDICHTUNG	JUNTA
16	R70010250	1	GUARNIZIONE OR 17,17 X 1,78 NBR-70	JOINT OR 17,17 X 1,78	OR GASKETS	RINGDICHTUNG 17,17 X 1,78	JUNTA OR 17,17 X 1,78
17	R70050130	1	GUARNIZIONE TUBO SFIATO D.50	JOINT	GASKETS	RINGDICHTUNG	JUNTA
18	R62030118	1	MANICOTTO RIDUZ.F.1/8-1/4 CIL. PRDI222100	1/8"-1/4" FEMALE REDUCTION COUPLING	MANCHON REDUCTION 1/8" - 1/4"	REDUZIERMUFFE 1/8" - 1/4" F	MANGUITO REDUCCION HEMBRA 1/8"-1/4"
19	R69030280	1	MANOPOLA ENCODER D.42 BLU FA 6264	KNOB KIT	POIGNEE COMMANDE	DREHKNOFF	PULSADOR MANETA
20	R65260540	1	MICRO PORTA	DOOR SWITCH	MICRO PORTE	TUERSCHALTER	MICRO PUERTA
21	R65220280	1	MORSETTIERA MONOFASE C/TERRA PAS-SANTE	TERMINAL BOARD	BORNIER	KLEMMLEISTE	REGLETERA
22	R65041040	1	MOTORE 1F.125Win-75Wout 2VEL C/COND. FIR	MOTOR	MOTEUR	MOTOR	MOTOR
23	R69010260	1	NASELLO 1 STEP 6303-020022	DOOR LATCH 1 STEP	GACHE DE PORTE POUR OUVERTURE SIMPLE	SCHLISSNASE 1 STUFE	NARIZ 1 CIERRE
24	R58002520	1	PERNO INF. CERNIERA REG. V/061-102	LOWER HINGE PIN	CHEVILLE CHARNIERE INFERIEURE	UNTERES SIE SCHARNIERSTIFT	PERNO INFERIOR BISAGRA
25	R58002150	1	PERNO SUP. CERNIERA REG. M/106-220	UPPER HINGE PIN	CHEVILLE CHARNIERE SUPERIEURE	OBERES SCHARNIERSTIFT	PERNO SUPERIOR BISAGRA
26	R58001850	8	PERNO SUPP. PARATIE M5 MIXTER	RACK HOLDER	BOLZEN AUFLAGESCHIENEN	SUPPORT GLISSIERE	PERNO SOPORTE MAMPARO
27	R65210020	5	PORTAFUSIBILE BARRA DIN 5x20	FUSE CARRIER	PORTE-FUSIBLE	SICHERUNGSHALTER	PORTAFUSIBILE
28	R65270510	1	PORTALAMPADA STAGNO ALPHATECH 77.705.U10	WATERPROOF LIGHT SOCKET	DOUILLE ETANCHEE	DICHTE LAMPEHALTERUNG	PORTALAMPARA ESTANCO
29	R65240010	1	PRESSACAVO PG 107 Z/16	FAIRLEAD	PRESSE CABLE	ZUGENTLASTUNG	PRENSACABLES
30	R63070050	1	PRESSOSTATO 1/8" 0,5-0,35 BAR PH/91140	WATER SAFETY PRESSURE SWITCH	INT.A PRESSION SEC.-EAU	WASSER-DRUCKWACHTER	PRESOSTATO AQUA
31	R80100100	1m	GUARNIZIONE CRUSCOTTO	JOINT	GASKETS	RINGDICHTUNG	JUNTA
32	R62090478	3	RACC. INTERMEDIO A GOMITO D.10 PM0310E	ELBOW PIPE FITTING	COURBE AVEC QUEUE	STUCK MIT SCHAFT	RACOR CON CODO
33	R62090458	1	RACC. INTERMEDIO DIRITTO D.10 PM0410E	PIPE FITTING	COURBE	STUCK	RACOR
34	R62090508	1	RACC.TERMIN.DIR.FIL.CON.10X1/4 PM011002E	10X1/4 STRAIGHT THREADED TERMINAL PIPE FITTING	RACCORDEMENT	ENDVERBINDUNGSSTUCK 10 X 1/4" GESCHNITTEN	RACOR
35	R65170100	2	RELE' FINDER 628282300309PSA	RELAY	RELAIS	RELAIS	RELE
36	R65301950	1	SCHEDA ESPANSIONE BRUCIATORI "X" Sr.2006	BOILER CONTROL PC BOARD	FICHE ELECTRON. CONTROLE CHAUDIERE	ESPANSIONSPLATINE	PLACA EXPANSION
37	R65302390	1	SCHEDA "X" COMPACT COMPLETA SANDWICH	CONTROL PC BOARD	PLATINE ÉLECTRONIQUE COMPLÈTE	STEUERPLATINE KOMPLETT	PLACA COMPLETA
38	R65302410	1	SCHEDA BASE "X" COMPACT	MAIN PC BOARD	PLATINE ÉLECTRONIQUE DE BASE	HAUPTPLATINE	PLACA BASE

**TAV. A**

**CVG 051 X**

**ATTENZIONE:** PER ORDINARE I RICAMBI, SPECIFICARE SEMPRE IL MODELLO DI FORNO ED IL NUMERO DI MATRICOLA  
**ATTENTION:** WHEN ORDERING SPARE PARTS, PLEASE ALWAYS SPECIFY THE OVEN MODEL AND THE SERIAL NUMBER

**ATTENTION:** POUR COMMANDER DES PIÈCES, MERCI DE SPECIFIER TOUJOURS LE MODÈLE DU FOUR ET LE NUMÉRO DE SÉRIE  
**ACHTUNG:** UM ERSATZTEILE ZU BESTELLEN, BITTE IMMER OFEN-MODELL UND SERIENNUMMER GEBEN.

ed. 0713

POS.	COD.	Pz.	DESCRIZIONE	DESCRIPTION	DESCRIPTION	BESCHREIBUNG	DESCRIPCIÓN
39	R65302420	1	SCHEDA DISPLAY "X" COMPACT	DISPLAY PC BOARD	PLATINE ÉLECTRONIQUE DISPLAY	DISPLAYPLATINE	PLACA DISPLAY
40	R65302400	1	SCHEDA ESPANSIONE "S"- "X" COMPACT	CONTROL PC BOARD	FICHE ELECTRON. CONTROLE	ESPANSIONSPLATINE	PLACA EXPANSION
41	R65302440	1	SCHEDA TASTIERA "X" COMPACT SANDWICH	CONTROL PANEL PC BOARD	PLATINE ÉLECTRONIQUE COMMANDES	TASTAURPLATINE	PLACA PULSADORES
42	R65320220	2	SONDA "K" 6X80 1,5ML. TESTA RASTREM. 20mm	PROBE "K" 6X80 1,5ML.	SONDE "K" 6X80 1,5ML.	FUEHLER "K" 6X80 1,5ML.	SONDA "K" 6X80 1,5ML.
43	R65321102	1	SONDA AL CUORE K 4 PUNTI 6 PIN.IMP.2012	CORE TEMPERATURE PROBE	SONDE A COEUR	KERNTEMPERATURFUEHLER	SONDA AL CORAZON
44	R65321110	1	CONNETTORE FEMM. S/CUORE 6 PIN	CORE TEMPERATURE PROBE FEMALE CONNECTOR	CONNECTEUR FEMELLE POUR SONDE A COUER	STECKDOSE F. KERNTemperaturFUEHLER	CONECTOR HEMBRA PARA SONDA AL CORAZON
45	R65321020	1	TAPPO X CONNETTORE 4 PIN.	COVER FOR CONNECTOR	BOUCHON POUR CONNECTEUR	ABDECKUNG STECKDOSE	TAPON PARA CONECTOR
46	R86020400	1	VALIGETTA X SONDA AL CUORE TRASPARENTE	CORE TEMPERATURE PROBE BOX	PETITE VALISE SONDE A COEUR	TASCHE F. KERNTemperaturFUEHLER	ESTUCHE DE SONDA AL CORAZON
47		1	TASTIERA	PLATE	PLAQUE	BEDIENUNGSFOLIE	TARJETA
48	R70044340	1	TELAIO GUARN. PORTA A V-C 05	FRONT GASKET	JOINT FACADE	DICHTUNG DER FRONTSEITE	JUNTA FRONTAL
49	R63070010	1	PRESSOSTATO PG 901.61	GAS SAFETY PRESSURE SWITCH PG 901.61	INT.A PRESSION SECURITE-GAZ PG 901.61	DRUCKSCHALTER PG 901.61	PRESOSTATO GAS PG 901.61
50	R65070350	1	TERMOSTATO SICUR. 360°C -25K 55.32572.8	THERMOSTAT	THERMOSTAT	THERMOSTAT	TERMOSTATO
51	R65180420	2	TRASF.RE 20VA 0-220-240/12V MOD.163.16	TRANSFORMER	TRANSFORMATEUR	TRANSFORMATOR	TRANSFORMADOR
52	R80150000	1m	TUBO PE 10MMX7 AZZURRO PM950612E	BLUE PIPE	TUBE	LEITUNG	TUBO
53	R58006160	1	UGELLO COND.D.0,8 CODOLO CIL.10	NOZZLE	BEC	DÜSE	BOQUILLA
54	R65060050	1	VENTILATORE COMPATTO D.120 4715MS 23T	COMPONENTS VENTILATION MOTOR	MOTEUR DE REFRROIDISSEMENT	ABKULUNGS MOTOR	MOTOR DE ENFRIAMIENTO
55	R75400410	1	VENTOLA D.180X77/12 50HZ P.D.	FAN	TURBINE	LUEFTERRAD	PALA VENTILADOR
56	R18100130	1	PORTA COMPLETA E_051	DOOR ASSEMBLY	PORTE COMPLETE	TUER KOMPLETT	PUERTA COMPLETA
57	R65110500	1	REGOL. PORT. MARR. ATCH. 10lt/h	10 LT/H WATER FLOW REDUCER	REGULATUER DE DEBIT 10 LT.	DURCHFLOSSMONDERER 10L/STD.	REGULADOR DE CAUDAL 10 LT.
58	R75300150	1	GRIGLIA VENTILATORE D.170	FAN GUARD GRID D.170	GRILLE VENTILATEUR D.170	VENTILATORSCHUTZGITTER D.170	REJILLA VENTILADOR D.170
59	R70060080	1	MANICOTTO SILICONE D.13X18X80	SILICON SLEEVE	SILICONE SLEEVE	SILIKONHÜLLE	FUNDA DE SILICONA
60	R70060090	1	MANICOTTO SILICONE D.24X30X40	SILICON SLEEVE	SILICONE SLEEVE	SILIKONHÜLLE	FUNDA DE SILICONA
61	R65060010	1	VENTILATORE COMPATTO D.80 TP.W2S 076	COMPONENTS VENTILATION MOTOR	MOTEUR DE REFRROIDISSEMENT	ABKULUNGS MOTOR	MOTOR DE ENFRIAMIENTO
62	R65190240	1	CONDENSATORE 10µF C/USCITA 4 FAETON 6,35	CAPACITOR	CONDENSATEUR	KONDENSATOR	CONDENSADOR
63	R65170050	1	RELE' 4052 240V AC 8/5A	RELAY	RELAIS	RELAIS	RELE
64	R65170170	1	RELE' FINDER 628282300009PSA CONT. SCAMB.	RELAY	RELAIS	RELAIS	RELE
65	R58005500	1	FLANGIA GUARNIZIONE MOTORE	MOTOR GASKET BRASS FLANGE	BRIDE JOINT MOTEUR	FLANSCH F. MOTORDICHTUNG	BRIDA JUNTA MOTOR
66	R65301930	1	SCHEDA ON-OFF TOP LCD "X" Sr.2006	ON-OFF BOARD "X"	ON-OFF PANNEAU "X"	ON-OFF PLATINE "X"	ON-OFF PLACA "X"
P1	R18203060	1	PORTA ESTERNA E_051	EXTERNAL DOOR	PORTE D'EXTERNAL	AUSSENTÜR	PUERTA EXTERNA
P2	R71201570	1	VETRO POST. PORTA E_051 623x475x6	DOOR GLASS	VITRE PORTE	HARTGLASS	VIDRIO PUERTA
P3	R58001780	2	FERMO VETRO PORTA P2000	INNER GLASS CATCH KIT	ENSEMBLE ARRET VERRE INTERIEUR	VERSCHLUSSSATZ F. INNENSCHIEBE	KIT FIJACION VIDRIO INTERNO
P4	R61620132	1	MOLLA AGGANCIAMENTO NASELLO	DOOR LOCK SPRING	RESSORT DE FERMETURE PORTE	TÜR SCHLUSSFEDER	MUELLE DE ENGANCHE A TRINQUET
P5	R18404520	2	SPESSORE PROTEZIONE VETRO	THICKNESS	EPAISSEUR	DICKE	ESPEJOR
P6	R11423460	2	PROTEZIONE VETRO PORTA K E T 2011	GLASS PROTECTION	PROTECTION DE VERRE	GLASSCHUTZ	PROTECCION VIDRIO
P7	R58001760	2	CERNIERA FISSA VETRO SR2000	INNER GLASS SOLID HINGE	CHARNIERE VERRE INTERIEUR	SCHARNIER F. INNENSCHIEBE	BISAGRA FIJA VIDRIO INTERNO
P8	R58001770	2	PERNO CERNIERA VETRO SR2000	INNER GLASS HINGE PIN	PIVOT CHARNIERE VERRE INTERIEUR	SCHARNIERBOLZEN F. INNENSCHIEBE	PERNO BISAGRA VIDRIO INTERNO
P9	R70050100	6	TASSELLO BATTUTA VETRO SR.2000	GLASS SILICON SPACERS	GOUJON SILICONIQUE ARRETE-VITRAGE PORTE	SILIKONANSCHLAG F. INNENSCHIEBE	TOPE GOLPE VIDRIO
P10	R58001860	1	PERNO SUPP. PARATIE ALPHATECH	RACK HOLDER	SUPPORT GLISSIERE	BOLZEN AUFLAGESCHIENEN	PERNO SOPORTE MAMPARO
P11	R69010210	1	GRUPPO CHIU.BASC.C/AN.CROM.6303-BLU-STD	DOOR CATCH KIT	ENSAMBLE FERMETURE PORTE	VERSCHLUSSSATZ	MANIJA DE LA PUERTA
P12	R69010630	1	COP. INT. MECC. CHIUS. GRUPPO 6303	DOOR HANDLE	POIGNEE DE PORTE	GRIFFKORPUS	CUERPO MANETA

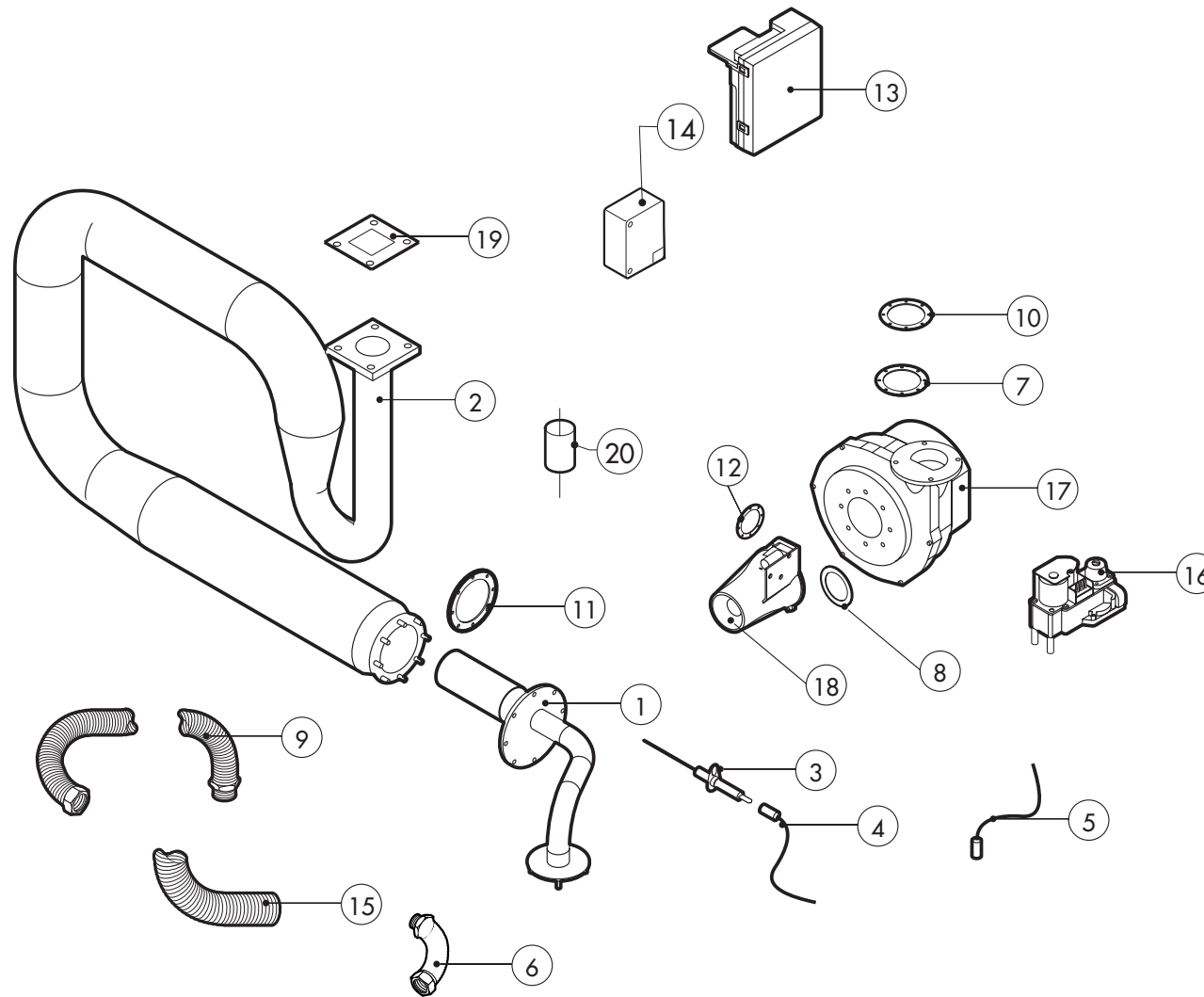



**ATTENZIONE:** PER TENSIONI SPECIALI, SPECIFICARE SEMPRE IL MODELLO DI FORNO ED IL NUMERO DI MATRICOLA  
**ATTENTION:** FOR SPECIAL VOLTAGES, PLEASE ALWAYS SPECIFY THE OVEN MODEL AND THE SERIAL NUMBER

**ATTENTION:** POUR TENSIONS SPÉCIALES, MERCI DE SPÉCIFIER TOUJOURS LE MODÈLE DU FOUR ET LE NUMÉRO DE SÉRIE  
**ACHTUNG:** BEI SONDRERSPANNUNGEN, BITTE IMMER OFEN-MODELL UND SERIENNUMMER GEBEN.

ed. 0713

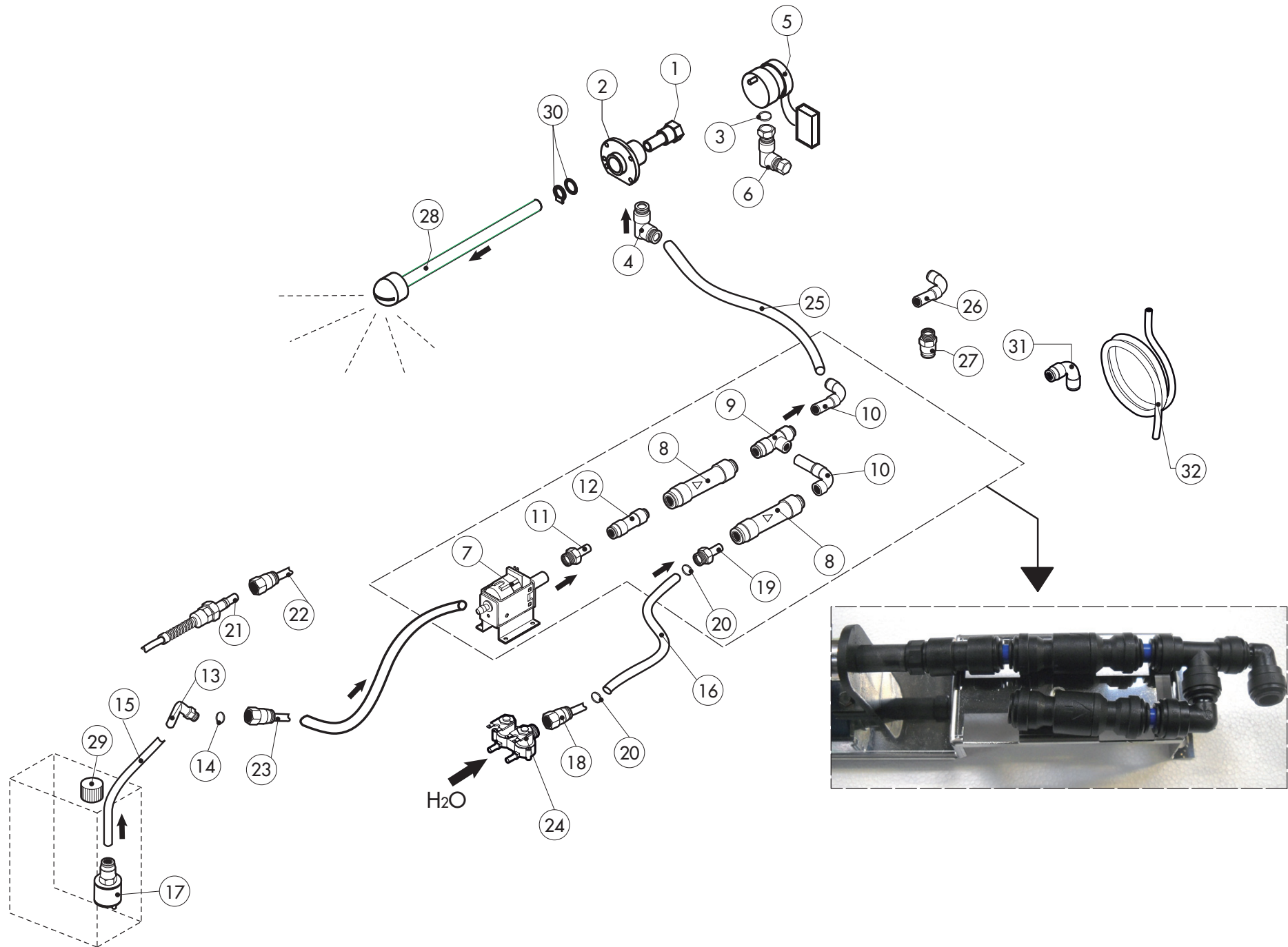



POS.	COD.	Pz.	DESCRIZIONE	DESCRIPTION	DESCRIPTION	BESCHREIBUNG	DESCRIPCIÓN
1	R58007000	1	PERNO ROTANTE LAVAGGIO MOB	ROTATING PIVOT	PIVOT TOURNANT	UMLAUFENDE STÜTZE	GOZNE ROTATORIO
2	R58007020	1	FLANGIA LAVAGGIO MOB	WASHING SYSTEM FLANGE	BRIDE BRAS DE LAVAGE	FLANSCH WASCHARMBEFESTIGUNG	PLATINA LAVADO
3	R70010080	1	GUARNIZIONE OR 14x2 Viton DIN 981	JOINT OR 14x2	OR GASKETS	RINGDICHTUNG 14x2	JUNTA OR 14x2
4	R62090663	1	RACCORDO OTTONE NICH.A L C/OGIVA 10X1/4"	ELBOW PIPE FITTING BRASS D.10x1/4"	RACCORDEMENT A COUDE LAITON D 10x1/4"	ELBOW PIPE FITTING BRASS D.10x1/4"	RACOR LATON DE GOMA D.10x1/4"
5	R65090250	1	MOTORID.LAV.SAIA-BURGESS 175022044028-A	WASHING GEARED MOTORS	MOTO-REDUCTEURS DE LAVAGE	GETRIEBEMOTOREN	MOTORREDUCTORES LAVADO
6	R62090633	1	RACCORDO OTTONE CURVO 10/10 C/OGIVA	ELBOW PIPE FITTING BRASS D.10	RACCORDEMENT A COUDE LAITON D 10	WINKELSTUTZEN AUS MESSING D,10	RACOR LATON DE GOMA D.10
7	R65110600	1	POMPA ELETTRON.A PIS.OSC.ET508LAB 2273	POMPE DETERGEANT	DETRGENT PUMP	REINIGERPUMPE	BOMBA DETERGENTE
8	R65110680	2	VALVOLA ANTIRITORNO J.G. 10SCV	ANTI-BACK FLOW	ANTIRETOUR	RUCKFLUSSVERHINDERER	ANTIRETORNO
9	R62090468	1	RACCORDO INTERMEDIO A "T" D.10 PM0210E	T MIDLING PIPE FITTING D.10	RACCORD INTERMEDIAIRE A "T" D.10	MITTELVERBINDUNGSSTUCK D.10 "T"- FORMIG	RACOR INTERMEDIO TIPO "T" D.10
10	R62090528	5	RACC.A GOMITO C/CODOLO 10X10 PM221010E	ELBOW PIPE FITTING (WITH TANG) 10 X 10	COURBE AVEC QUEUE 10x10	WINKELVERBINDUNGSSTUCK 10 X 10 MIT SCHAFT	RACOR DE GOMA CON CODO 10x10
11	R62090608	1	TERMINALE C/CODOLO 8x1/8" PM050811E	8X1/8 END SIDE PIPE FITTING (WITH TANG)	RACCORD AVEC QUEUE 8x1/8"	ENDVERBINDUNGSSTUCK 8 X 1/8" MOT SCHAFT	RACOR TERMINAL CON CODO 8x1/8"
12	R62090618	1	RIDUZIONE INTERMEDIA 10-8 PM201008E	REDUCTION PIPE FITTING	RACCORD DROIT REDUCTION	GERADE ANSCHLUSS-VERKLEINERUNG	RACOR DERECHO REDUCCION
13	R62090678	2	RACC.A GOMITO C/CODOLO 8X8 PM220808E	ELBOW PIPE FITTING (WITH TANG) 8 X 8	COURBE AVEC QUEUE 8x8	WINKELVERBINDUNGSSTUCK 8X8 MIT SCHAFT	RACOR DE GOMA CON CODO 8x8
14	R70010050	4	GUARNIZIONE OR 7,60 X 2,62 OR 3030 NB	JOINT OR 7,60x2,62	OR GASKETS	RINGDICHTUNG 7,60x2,62	JUNTA OR 7,60x2,62
15	R80150020	1,6m	TUBO DETERGENTE PE D.8mm x 6	PE D.8 MM X 6 DETERGENT FLEXIBLE PIPE	TUBE DETERGEANT D. 8x6	ROHRLEITUNG F. REINIGER PE D.8MMX6 (2MT)	TUBO DETERGENTE PE D.8mm X 6
16	R80150040	1m	TUBO CARICO ACQUA D.23mm x 13	FLEXIBLE PIPE	TUBE FLEXIBLE EAU	WASSERFLEXROHRLEITUNG	TUBO FLEXIBLE AGUA
17	R65110650	1	VALVOLA DI FONDO PER FILTRO GM.060.35	BOTTOM FILTER	FILTER POUR TUBE DETERGEANT	ANSAUGFILTER F. REINIGUNGSSCHAUCH	VÁLVULA DE FONDO TUBO DEL LIMPIADOR
18	R62090508	1	RACC.TERMIN.DIR.FIL.CON.10X1/4 PM011002E	10X1/4 STRAIGHT THREADED TERMINAL PIPE FITTING	RACCORD FILET DROIT 10x1/4"	ENDVERBINDUNGSSTUCK 10 X 1/4" GESCHNITTEN	RACOR TERMINAL DERECHO ROSCADO 10x1/4"
19	R62090608	1	TERMINALE C/CODOLO 8x1/8" PM050811E	8X1/8 END SIDE PIPE FITTING (WITH TANG)	RACCORD AVEC QUEUE 8x1/8"	ENDVERBINDUNGSSTUCK 8 X 1/8" MOT SCHAFT	RACOR TERMINAL CON CODO 8x1/8"
20	R61630011	2	FASCETTE ZINC.12-22/9	METAL CLAMPS 12-22/9	COLLIER DE SERRAGE 12-22/9	VERZINKTE SCHELLEN 12-22/9	ABRAZADERA 12-22/9
21	R62090482	1	RACC.RAPIDO MASCHIO X LAVAG. PIPU40-C08M	RAPID MALE PIPE FITTING	RACCORD RAPIDE PARTIE MALE	SCHNELLVERBINDUNG MANNL	RACOR RAPIDO MACHO
22	R62090638	1	RACC.RAP.FEMM.X LAV.FIL.FEMM PVPU40-F1/4	RAPID FEMALE PIPE FITTING	RACCORD RAPIDE PARTIE FEMELLE	SCHNELLVERBINDUNG	RACOR RAPIDO HEMBRA
23	R62090538	1	RACC.DIR.F.1/4" TUBO6X8 A CALZ. PRCF220008	1/4" FEMALE STRAIGHT PIPE FITTING FOR D.6X8 PIPE	RACCORD DROIT PARTIE FEMELLE 1/4" TUBE 6x8	VERBINDUNGSSTUCK 1/4" WEBL. FUR ROHR D.6X8	RACOR DERECHO HEMBRA 1/4" PARA TUBO D.6x8
24	R65110210	1	E.V. 2 VIE 220V 50HZ X J.G.CON ATTACC	SOLENOID VALVE 220V 50HZ	ELECTROVANNE 220V 50HZ	MAGNETVENTIL 220V 50HZ	ELECTROVALVULA 220V 50HZ
25	R80150000	1m	TUBO PE D.10mm x 7 AZZURRO	PE D.10 MM X7 WATER FLEXIBLE PIPE	TUBE FLEXIBLE EAU D. 10x7	WASSERFLEXROHRLEITUNG PE D.10MMX7	TUBO FLEXIBLE AGUA PE D.10mm X 7
26	R62090678	1	RACC.A GOMITO C/CODOLO 8X8 PM220808E	ELBOW PIPE FITTING (WITH TANG) 8 X 8	COURBE AVEC QUEUE 8x8	WINKELVERBINDUNGSSTUCK 8X8 MIT SCHAFT	RACOR DE GOMA CON CODO 8x8
27	R62090688	1	RACC.TERMIN.DIR.FIL.CON.8X1/4 NC2500-P	8x1/4 STRAIGHT THREADED TERMINAL PIPE FITTING	RACCORD FILET DROIT 8x1/4"	ENDVERBINDUNGSSTUCK 8x1/4" GESCHNITTEN	RACOR TERMINAL DERECHO ROSCADO 8x1/4"
28	R58007050	1	TESTA LAVAGGIO MOB+ALBERO L=110 (M_051)	WASHING SYSTEM INNER ASSEMBLY	ENSEMBLE INTERIEUR DU LAVAGE	INNEN WASCHARMBEFESTIGUNG	KIT INTERNO LAVADO
29	R58005060	1	TAPPO TANICA GIALLO x LAVAGGIO	COVER	BOUCHON	ABDECKUNG	TAPON
30	R70045120	1	KIT GUARNIZIONI X LAVAGGIO MOB	GASKETS KIT	ENSEMBLE JOINTS	DICHTUNGSSATZ	KIT JUNTAS
31	R62090478	1	RACC. INTERMEDIO A GOMITO D.10 PM0310E	ELBOW PIPE FITTING	COURBE AVEC QUEUE	STUCK MIT SCHAFT	RACOR CON CODO
32	R70070080	1m	TUBO GOMMA PER ALIMENTI Di13 De23 L=1MT	PIPE	TUBE	LEITUNG	TUBO