

ATTENZIONE: PER TENSIONI SPECIALI, SPECIFICARE SEMPRE IL MODELLO DI FORNO ED IL NUMERO DI MATRICOLA
ATTENTION: FOR SPECIAL VOLTAGES, PLEASE ALWAYS SPECIFY THE OVEN MODEL AND THE SERIAL NUMBER

ATTENTION: POUR TENSIONS SPÉCIALES, MERCI DE SPÉCIFIER TOUJOURS LE MODÈLE DU FOUR ET LE NUMÉRO DE SÉRIE
ACHTUNG: BEI SONDRSPANNUNGEN, BITTE IMMER OFEN-MODELL UND SERIENNUMMER GEBEN.

ed. 0713

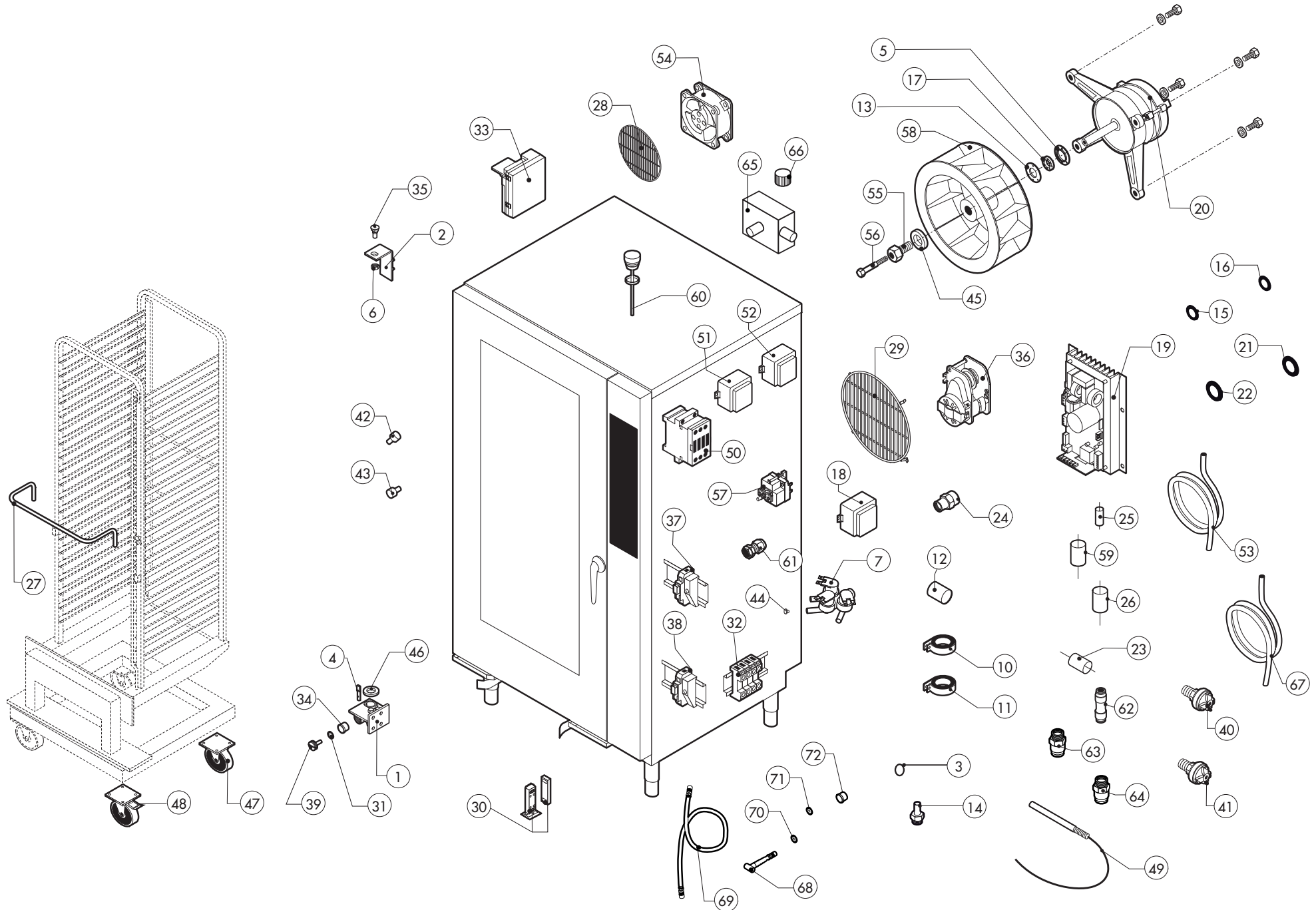

POS.	COD.	Pz.	DESCRIZIONE	DESCRIPTION	DESCRIPTION	BESCHREIBUNG	DESCRIPCIÓN
1	R11205390	1	ASS. CERNIERA INFERIORE M-V/201-202	LOWER DOOR HINGE	CHARNIERE INFÉRIEURE PORTE	UNTERES SCHARNIER	BISAGRA INFERIOR
2	R11426830	1	CERNIERA SUPERIORE PORTA SR.2013	UPPER HINGE	CHARNIERE SUPÉRIEUR	OBERES SCHARNIER	BISAGRA SUPERIOR
3	R62070023	1	BICONO PILOTA TUBO D.6 905.	BICONE D.6	BICONE D. 6	KEGEL D.6	BICONO D.6
4	R58002540	1	CHIAVETTA X PERNO C/FERMO PORT M-V/120-22	DOOR PIVOT SUNK KEY	CLAVETTE POUR CHEVILLE PORTE	KEIL F. TUERSTIFT	LLAVE PARA PERNO PUERTA
5	R58003850	2	CONTRORFLANGIA GUARNIZIONE GRANDE	MOTOR GASKET BRASS COUNTER FLANGE	CONTRE- BRIDE JOINT MOTEUR	GEGENFLANSCH F. MOTORDICHTUNG	CONTRABRIDA JUNTA MOTOR
6	R58004050	1	DADO PER PERNO CERNIERA SUPERIORE	NUT FOR UPPER DOOR HINGE	ECROU CHEVILLE CHARNIERE SUPÉRIEURE	MUTTER F. OBERES SCHARNIERSTIFT	TUERCA PARA PERNO BISAGRA SUPERIOR
7	R65110270	1	ELETTROVALVOLA 4 VIE 220V/50HZ J.G.CON ATTACC	SOLENOID VALVE	ELECTROVANNE	MAGNETVENTIL	ELECTROVALVULA
8	R65240020	1	CONTRODADO PG 116/16/NY	CABLE GLAND LOCK NUT	CONTRE-ECROU POUR RONDELLE FIXATION	MUTTER	CONTRODADO PASACABLE
9	R62280038	1	CURVA C/MORSET.HTS-HTSW X TUBO D.50 D.50X	CURVE WITH TERMINAL	COURBE AVEC BORNIER	KURVE MIT KLEMM	CURVA CON REGLETERA
10	R65280490	1	FERRITE TOROIDALE FT36	FERRITE FT36	FERRITE FT36	FERRIT FT36	FERRITA FT36
11	R65280480	2	FERRITE TOROIDALE FT25	FERRITE FT25	FERRITE FT25	FERRIT FT25	FERRITA FT25
12	R65280240	1	FILTRO FLC470501F	INTERFERENCE SUPPRESSOR	FILTRE ANTIPARASITES	STOERSCHUTZFILTER	FILTRO
13	R58003840	2	FLANGIA GUARNIZIONE GRANDE	MOTOR GASKET BRASS FLANGE	BRIDE JOINT MOTEUR	FLANSCH F. MOTORDICHTUNG	BRIDA JUNTA MOTOR
14	R62060223	1	DADO PILOTA TUBO D.6 0903/1.	NUT D.6	ECROU D. 6	MUTTER D.6	DADO D.6
15	R70010030	1	GUARNIZIONE OR 6,07 X 1,78 SILICONE	GASKET OR 6,07 X 1,78	JOINT OR 6,07 X 1,78	RINGDICHTUNG OR 6,07 X 1,78	JUNTA OR 6,07 X 1,78
16	R70010050	1	GUARNIZIONE OR 7,60 X 2,62 OR 3030 NB	GASKET OR 7,60 X 2,62	JOINT OR 7,60 X 2,62	RINGDICHTUNG OR 7,60 X 2,62	JUNTA OR 7,60 X 2,62
17	R70020050	2	GUARNIZIONE MARK IV MLA 2400.02.05	MOTOR GASKET	GARNITURE MOTEUR	MOTORDICHTUNG	JUNTA MOTOR
18	R65450200	1	INDUTTANZA 6,5 mH 8A	INDUCTANCE	INDUCTANCE	INDUKTANZ	INDUCTANCIA
19	R65140890	1	INVERTER 0.5KW MOT.INFA001M005XSB X RIC	INVERTER	INVERSEUR	INVERTER	INVERSOR
20	R65040530	1	MOTORE KW 055 F3 4P 3039 200-440V I	MOTOR	MOTEUR	MOTOR	MOTOR
21	R70010210	1	GUARNIZIONE OR NBR 70 18,72x2,62 C.3075	GASKET OR 18,72x2,62	JOINT OR 18,72x2,62	RINGDICHTUNG OR 18,72x2,62	JUNTA OR 18,72x2,62
22	R65070230	1	GUARNIZIONE PER TERM.SIC.CA-MERM/106-110	GASKET	JOINT	RINGDICHTUNG	JUNTA
23	R62090713	1	MANICOTTO FF 3/4"-1/2" OT	COUPLING	MANCHON	MUFFE	FUNDA
24	R62030118	1	MANICOTTO RIDUZIONE FEMMINA 1/8"-1/4"	1/8"-1/4" FEMALE REDUCTION COUPLING	MANCHON REDUCTION 1/8" - 1/4"	REDUZIERMUFFE 1/8" - 1/4" F	FUNDA
25	R70060080	1	MANICOTTO SILICONE Ø 13	SILICON SLEEVE Ø 13	SILICONE SLEEVE Ø 13	SILIKONHÜLLE Ø 13	FUNDA DE SILICONA Ø 13
26	R70060040	2	MANICOTTO SILICONE Ø 50	SILICON SLEEVE Ø 50	SILICONE SLEEVE Ø 50	SILIKONHÜLLE Ø 50	FUNDA DE SILICONA Ø 50
27	R11210800	1	MANIGLIA CARRELLO PORTATEGLIE KS/156	HANDLE FOR TROLLY	POIGNÉE POUR CHARIOT PORTE POELES	HANDGRIF-LAUFKATZE	MANIJA CARRO PORTABANDEJAS
28	R75300020	3	MASCHERINA VENTILATORE Ø 120	FAN GUARD GRID D.120	GRILLE VENTILATEUR D.120	VENTILATORSCHUTZGITTER D.120	REJILLA VENTILADOR D.120
29	R75300090	2	MASCHERINA VENTILATORE Ø 350	FAN GUARD GRID D.350	GRILLE VENTILATEUR D.350	VENTILATORSCHUTZGITTER D.350	REJILLA VENTILADOR D.350
30	R65265100	1	MICRO PORTA MAGNETICO COMPLETO	DOOR SWITCH	MICRO PORTE	TUERSCHALTER	MICRO PUERTA
31	R61620091	16	MOLLA A TAZZA D.14/6,4X0,8 C70.	BELLEVILLE WASHER Ø 14/6.4	RESSORT A DISQUE Ø 14/6.4	TELLERFEDER Ø 14/6.4	MUELLE A DISCO Ø 14/6.4
32	R65220280	1	MORSETTIERA MONOFASE C/TERRA PAS-SANTE	TERMINAL BOARD	BORNIER	KLEMMLEISTE	REGLETERA
33	R63060160	2	PANNELLO ACCENS. S4565C1116B Ts=5 Tps=1	BURNER IGNITION PANEL	ALLUMEUR GAZ	ZUENDBOX	PANEL DE ENCENDIDO
34	R58002550	1	PATTINO FERMO PORTA M-V 120-220	DOOR RETAINER GUIDE SHOE	PATIN ARRET PORTE	GLEITSTUECK F. TUEARRETIERUNG	PATILLA CIERRE PUERTA
35	R58002150	1	PERNO SUPERIORE CERNIERA REG. M/106-220	UPPER HINGE PIN	CHEVILLE CHARNIERE SUPÉRIEURE	OBERES SCHARNIERSTIFT	PERNO SUPERIOR BISAGRA
36	R65090220	1	PROGRAMMAT. 1 CAMME V220/50HZ 1 CIRCUITO	DAMPER SYSTEM	SORTIE EVAPORATION MOUFLE	DAMPFABLAUSS-STELLMOTOR	MOTOR RESPIRADERO COMPLETO
37	R65210020	6	PORTAFUSIBILE BARRA DIN 5x20	FUSE CARRIER	PORTE-FUSIBLE	SICHERUNGSHALTER	PORTAFUSIBILE
38	R65210050	2	PORTAFUSIBILE BARRA DIN 6,3x32	FUSE CARRIER	PORTE-FUSIBLE	SICHERUNGSHALTER	PORTAFUSIBILE

POS.	COD.	Pz.	DESCRIZIONE	DESCRIPTION	DESCRIPTION	BESCHREIBUNG	DESCRIPCIÓN
39	R58002560	1	PRESSORE FERMO PORTA M-V/120-220	SCREW FOR LOWER DOOR HINGE	VIS POUR CHARNIERE INFERIEURE	DRUCKSCHRAUBE F. UNTERERS TUERSCHARNIER	TORNILLO PARA BISAGRA INFERIOR
40	R63070050	1	PRESSOSTATO ACQUA 1/8" 0,5-0,35 BAR	WATER SAFETY PRESSURE SWITCH	INT.A PRESSION SEC.-EAU	WASSER-DRUCKWACHTER	PRESOSTATO AQUA
41	R63070010	1	PRESSOSTATO PG 901.61	GAS SAFETY PRESSURE SWITCH	INT.A PRESSION SECURITE-GAZ	DRUCKSCHALTER PG	PRESOSTATO GAS
42	R58003140	2	PERNO AGGANCIAMENTO DEFLETTORE	T MIDLING PIPE FITTING D.10	RACCORD INTERMEDIAIRE A "T" D.10	MITTELVERBINDUNGSSTUECK D.10 "T"- FORMIG	RACOR INTERMEDIO TIPO "T" D.10
43	R58000160	2	PERNO FISS.DEFLETTORE K_081-101-A20-201	ELBOW PIPE FITTING	COURBE AVEC QUEUE	STUECK MIT SCHAFT	RACOR CON CODO
44	R65110510	2	REGOLATORE DI PORTATA ROSSO 15LT/H.	15 LT/H WATER FLOW REDUCER	REGULATUER DE DEBIT 15 LT.	DURCHFLOSSMONDERER 15L/STD.	REGULADOR DE CAUDAL 15 LT.
45	R58004010	2	RONDELLA FISSAGGIO VENTOLA Ø 30/12.5	FAN WASHER	RONDELLE TURBINE	UNTERLEGSCHIEBE	ARANDELA FIJACION TURBINA
46	R58002570	1	RONDELLA 30/15X3 M-V/120-220	WASHER	RONDELLE	UNTERLEGSCHIEBE	ARANDELA
47	R69090350	2	RUOTA GIR. DOPPIA D.100 (5940UAP100)	WHEEL	ROUE	RAD	RUEDA
48	R69090360	2	RUOTA GIR. DOPPIA C/FR. D.100 (5945UAP100)	WHEEL WITH BRAKE	ROUE AVEC LE FREIN	RAD MIT BREMSE	RUEDA CON EL FRENO
49	R65320220	1	SONDA "K" 6X80 1,5ML. TESTA RASTREM. 20mm	PROBE "K" 6X80 1,5 ML.	SONDE "K" 6X80 1,5ML.	FUEHLER "K" 6X80 1,5ML.	SONDA "K" 6X80 1,5ML.
50	R65140380	1	TELERUTTORE 3RT1016-1AP02 240V	CONTACTOR	CONTACTEUR	SCHUETZ	CONTACTOR
51	R65180420	2	TRASF.RE 20VA 0-220-240/12V MOD.163.16	TRANSFORMER 20VA	TRANSFORMATEUR 20VA	TRANSFORMATOR 20VA	TRANSFORMADOR 20VA
52	R65180430	1	TRASF.RE 40VA 0-220-240/12V MOD.163.82	TRANSFORMER 40VA	TRANSFORMATEUR 40VA	TRANSFORMATOR 40VA	TRANSFORMADOR 40VA
53	R80150000	4 m	TUBO PE 10MMX7 AZZURRO PM950612E	WATER FLEXIBLE PIPE	TUYAU FLEXIBLE EAU	WASSERFLEXROHRLEITUNG	TUBO FLEXIBLE AGUA
54	R65060050	4	VENTILATORE COMPATTO Ø 120	COMPONENTS VENTILATION MOTOR	MOTEUR DE REFRROIDISSEMENT	ABKÜHLUNGS MOTOR	MOTOR DE ENFRIAMIENTO
55	R58004000	2	VITE FISSAGGIO VENTOLA M12x1.5 SX	FAN SCREW M12x1.5 SX	VIS DE BLOCAGE TURBINE M12x1.5 SX	VENTILATORSCHRAUBE M12x1.5 SX	TORNILLO FIJACION TURBINA M12x1.5 SX
56	R61020562	2	VITE MOTORE TE A2 M6x55	MOTOR SCREW TE A2 M6x55	VIS DE BLOCAGE MOTEUR TE A2 M6x55	MOTORSCHRAUBE TE A2 M6x55	TORNILLO MOTOR TE A2 M6x55
57	R65070350	1	TERMOSTATO SICUREZZA CAMERA F2	THERMOSTAT	THERMOSTAT	THERMOSTAT	TERMOSTATO
58	R75400440	2	VENTOLA Ø 350x114/12 50HZ P.D.	FAN Ø 350x114/12 50HZ P.D.	TURBINE Ø 350x114/12 50HZ P.D.	LUEFTERRAD Ø 350x114/12 50HZ P.D.	PALA VENTILADOR Ø 350x114/12 50HZ P.D.
59	R70060020	1	MANICOTTO SILICONE D.30X35X9 TAPPO SFIA	SILICON SLEEVE	SILICONE SLEEVE	SILIKONHÜLLE	FUNDA DE SILICONA
60	R10100140	1	TAPPO SFIATO COMPLETO M/106-220	COVER	BOUCHON	ABDECKUNG	TAPON
61	R65240010	1	PRESSACAVO PG 107 Z/16	FAIRLEAD	PRESSE CABLE	ZUGENTLASTUNG	PRENSACABLES
62	R62090458	3	RACC. INTERMEDIO DIRITTO D.10 PM0410E	PIPE FITTING	COURBE	STUECK	RACOR
63	R62090508	1	RACC.TERMIN.DIR.FIL.CON.10X1/4 PM011002E	10X1/4 STRAIGHT THREADED TERMINAL PIPE FITTING	RACCORDEMENT	ENDVERBINDUNGSSTUECK 10 X 1/4" GESCHNITTEN	RACOR
64	R62090723	1	RIDUZIONE MF 1/2"-1/4" OT	REDUCTION	REDUCTION	VERRINGERUNG	REDUCCION
65	R69180100	1	SCATOLA COND.SCARICO H/MV 061-101-201	QUENCHING-DRAIN COLLECTOR	BOITE DE CONDENSATION DECHARGE	KONDENSATION-ABFLUSS SCHACHTEL	CAJON CONDENSACION-DESAGÜE
66	R62100108	1	TAPPO ROSSO D.10 (PM0810R)	COVER	BOUCHON	ABDECKUNG	TAPON
67	R80120060	5 m	TUBO SILIC. TRASP.SR60/TR 7/12.	PIPE	TUBE	LEITUNG	TUBO
68	R62200028	1	LANCIA DI LAVAGGIO SENZA TUBO	SHOWER HANDLE	POIGNEE DOUCHETTE	GRIFF F. HANDBRAUSE	MANGO DUCHA
69	R62200058	1	GOMMA 1/2"X1/2"X2.5M LANCIA L.2500 MM	FLEXIBLE PIPE SHOWER	TUBE FLEXIBLE DOUCHETTE	SCHEAUCH FUER HANDBRAUSE	TUBO FLEXIBLE DUCHA
70	R70030040	2	GUARNIZIONE D.16X24 3/4 GOMMA.	JOINT D.16X24	GASKETS D.16X24	RINGDICHTUNG D.16X24	VIDRIO D.16X24
71	R70030030	1	GUARNIZIONE D. 11X19 1/2"	JOINT D. 11X19	GASKETS D. 11X19	RINGDICHTUNG D. 11X19	VIDRIO D. 11X19
72	R69180300	1	SUPPORTO IN PLASTICA X DOCCIONE ESTERNO	HOLDER	SUPPORT	GESTELL	SOPORTE

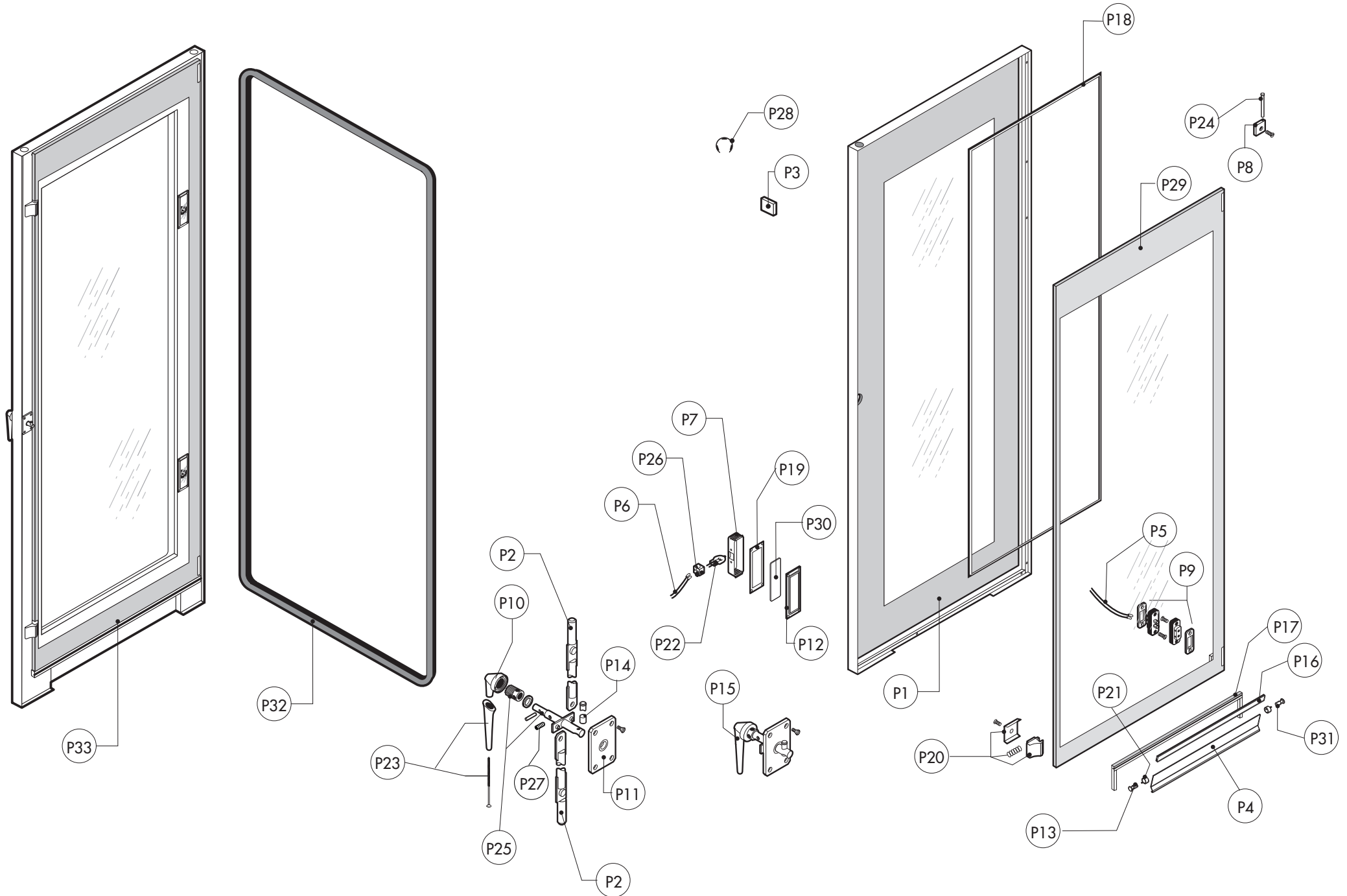

POS.	COD.	Pz.	DESCRIZIONE	DESCRIPTION	DESCRIPTION	BESCHREIBUNG	DESCRIPCIÓN
P1	R11207620	1	PORTA ESTERNA K_201	EXTERNAL DOOR	PORTE D'EXTERNAL	AUSSENTÜR	PUERTA EXTERNA
P2	R11207670	2	ASS.ASTINA AZ. PUNTONE K_201-202	ROD	CREMAILLERE	VERSCHLUSSTANGE	EJE
P3	R70050180	9	DISTANZIALE VETRO 15x8 SIL.55SH M4x12 A2	ROD	CREMAILLERE	VERSCHLUSSTANGE	EJE
P4	R11421580	1	BANDELLA DI TAMPONAMENTO K_201	CLOSING PLATE	TÔLE DE FERMETURE	VERSCHLUBLEISTE	PLACA DE CIERRE
P5	R66110300	1	CABLAGGIO CONTATTO LUCI	LAMPS CONTACT CABLE SET	CABLES CONTACT ECLAIRAGE	VERDRAHTUNG LICHTKONTAKT	CABLEADO CONTACTO LUCES
P6	R66110330	1	CABLAGGIO LUCI PORTA M-V/201-202	DOOR LAMPS CABLE SET	CABLES ECLAIRAGE PORTE	VERDRAHTUNG TURBELEUCHTUNG	CABLEADO LUCES PUERTA
P7	R11401440	2	CALOTTA LAMPADA SR. 2000	LAMP COVER	CALOTTE DE PROJECTEUR	LAMPENKALOTTE	CUBIERTA LAMPARA
P8	R58001760	2	CERNIERA FISSA VETRO SR.2000	HINGE	CHARNIERE	SCHARNIER	BISAGRA
P9	R65260750	1	CONTATTO PER LUCI SR.2000	LAMPS CONTACT BLOCK	CONTACT ECLAIRAGE	LICHTKONTSCHALTER	CONTACTO PARA LUZ
P10	R69010710	1	TAPPO MAN. GRIGIA GR.6303 C/ANELLO CROM.	DOOR HANDLE	POIGNEE DE PORTE	GRIFFKORPUS	CUERPO MANETA
P11	R03200970	1	FLANGIA BOCCOLA POSTERIORE	FLANGE	BRIDE	FLANSH	TAPA
P12	R11401450	2	FLANGIA STAMP. VETRO LAMPADA SR.2000	GLASS HOLDER LAMP FLANGE	BRIDE ARRET-VERRE ECLAIRAGE	FLANSH F.LAMPENVERGLASUNG	TAPA CRISTAL LAMPARA
P13	R58006861	2	FULCRO PER BANDELLA INS. MOLLA	PIVOT	AXE	DREHBOLZEN F.VERSCHLUBLEISTE	PIVOTE
P14	R58004781	1	GANCIO PERNO MANIGLIA C/NOTTOLO M/120-220	DOOR HANDLE HOOK	DECLIC AXE MANOEUVRE	HAKEN F. TUERGRIFF	GANCHO PERNO MANETA
P15	R11100312	1	GRUPPO CHIUSURA. COMPLETA G_T21-T40-AB_156 2012	DOOR CATCH KIT	ENSAMBLE FERMETURE PORTE	VERSCHLUSSSATZ	MANIJA DE LA PUERTA
P16	R80100910	0,4 m	GUARNIZIONE BANDELLA TAMPONAMENTO	CLOSING PLATE GASKET	JOINT TÔLE DE FERMETURE	DICHTUNG F.VERSCHLUBLEISTE	JUNTA PARA PLACA DE CIERRE
P17	R70044361	1	GUARNIZIONE BATTUTA CARRELLO CON TAMPONAMENTO K_201	GASKET	JOINT	DICHTUNG	JUNTA
P18	R80100100	3,6 m	GUARNIZIONE FACCIATA FRONTE	GASKET	JOINT	DICHTUNG	JUNTA
P19	R70044200	2	GUARNIZIONE VETRO LAMPADA P2000	LAMP GASKET	JOINT VERRE ECLAIRAGE	LAMPENDICHTUNG	VIDRIO CUBRELAMPARA
P20	R58001780	2	FERMO VETRO PORTA P2000	INNER GLASS CATCH KIT	ENSEMBLE ARRET VERRE INTERIEUR	VERSCHLUSSSATZ F. INNENSCHIEBE	KIT FIJACION VIDRIO INTERNO
P21	R65491250	1	KIT MOLLE BANDELLA TAMPONAMENTO	CLOSING PLATE SPRING ASSEMBLY	KIT RESSORTS TÔLE DE FERMETURE	FEDERSATZ F.VERSCHLUBLEISTE	KIT RESORTE DE PLACA DE CIERRE
P22	R65270020	2	LAMPADA ALOGENA 20W 12V G4 49040	LIGHT 20W 12V G4	LAMPE 20W 12V G4	LAMPENHALTERUNG	LAMPARA HALOGENA 20W 12V G4
P23	R69010820	1	MANIGLIA GRIGIA GR.6303 VERS.2011	HANDLE	POIGNEE	TUERGRIFF	MANGO MANETA
P24	R58001770	2	PERNO CERNIERA VETRO SR.2000	INNER GLASS HINGE PIN	PIVOT CHARNIERE VERRE INTERIEUR	SCHARNIERBOLZEN F. INNENSCHIEBE	PERNO BISAGRA VIDRIO INTERNO
P25	R11205340	1	PERNO MANIGLIA M-V/201-202	DOOR HANDLE PIN	AXE MANOEUVRE	SCHLISSNASE AM TUERGRIFF	PERNO MANETA
P26	R65270450	2	PORTAL. STUCCHI ART.216	LIGHT SOCKET	DOUILLE	LICHTKONTSCHALTER	PORTALAMPARA PARA LAMPARA HALOGENA
P27	R61090052	1	VITE STEI M6x16	GRUB SCREW M6x16	VIS SANS TETE M6x16	SENKOPFSCHRAUBE M6x16	TORNILLO SIN CABEZA M6X16
P28	R61600031	2	ANELLO ELASTICO RADIALE D.3,2 UNI 7434	ELASTIC RING	ANNEAU ÉLASTIQUE	ELASTICHER RING	ANILLO ELASTICO
P29	R71201870	1	VETRO INTERNO PORTA K_201-202	INNER DOOR GLASS	VERRE INTERIEUR PORTE	INNERES TÜRGLAS	VIDRIO INTERNO PUERTA
P30	R71500150	2	VETRO LAMPADA P2000	GLASS LAMP	VERRE PROTECTION LAMPE	LAMPLENCILAS	VIDRIO LAMPARA
P31	R58006910	2	FULCRO FISSAGGIO BANDELLA	PIVOT	AXE	DREHBOLZEN F.VERSCHLUBLEISTE	PIVOTE
P32	R70044910	1	TELAIO GUARN. PORTA K_201	FRONT GASKET	JOINT FACADE	DICHTUNG DER FRONTSEITE	JUNTA FRONTAL
P33	R11105000	1	PORTA COMPLETA K_201/AB_156 NEUTRA	DOOR ASSEMBLY	PORTE COMPLETE	TUER KOMPLETT	PUERTA COMPLETA

ATTENZIONE: PER TENSIONI SPECIALI, SPECIFICARE SEMPRE IL MODELLO DI FORNO ED IL NUMERO DI MATRICOLA
ATTENTION: FOR SPECIAL VOLTAGES, PLEASE ALWAYS SPECIFY THE OVEN MODEL AND THE SERIAL NUMBER

ATTENTION: POUR TENSIONS SPÉCIALES, MERCI DE SPÉCIFIER TOUJOURS LE MODÈLE DU FOUR ET LE NUMÉRO DE SÉRIE
ACHTUNG: BEI SONDRSPANNUNGEN, BITTE IMMER OFEN-MODELL UND SERIENNUMMER GEBEN.

ed. 0713

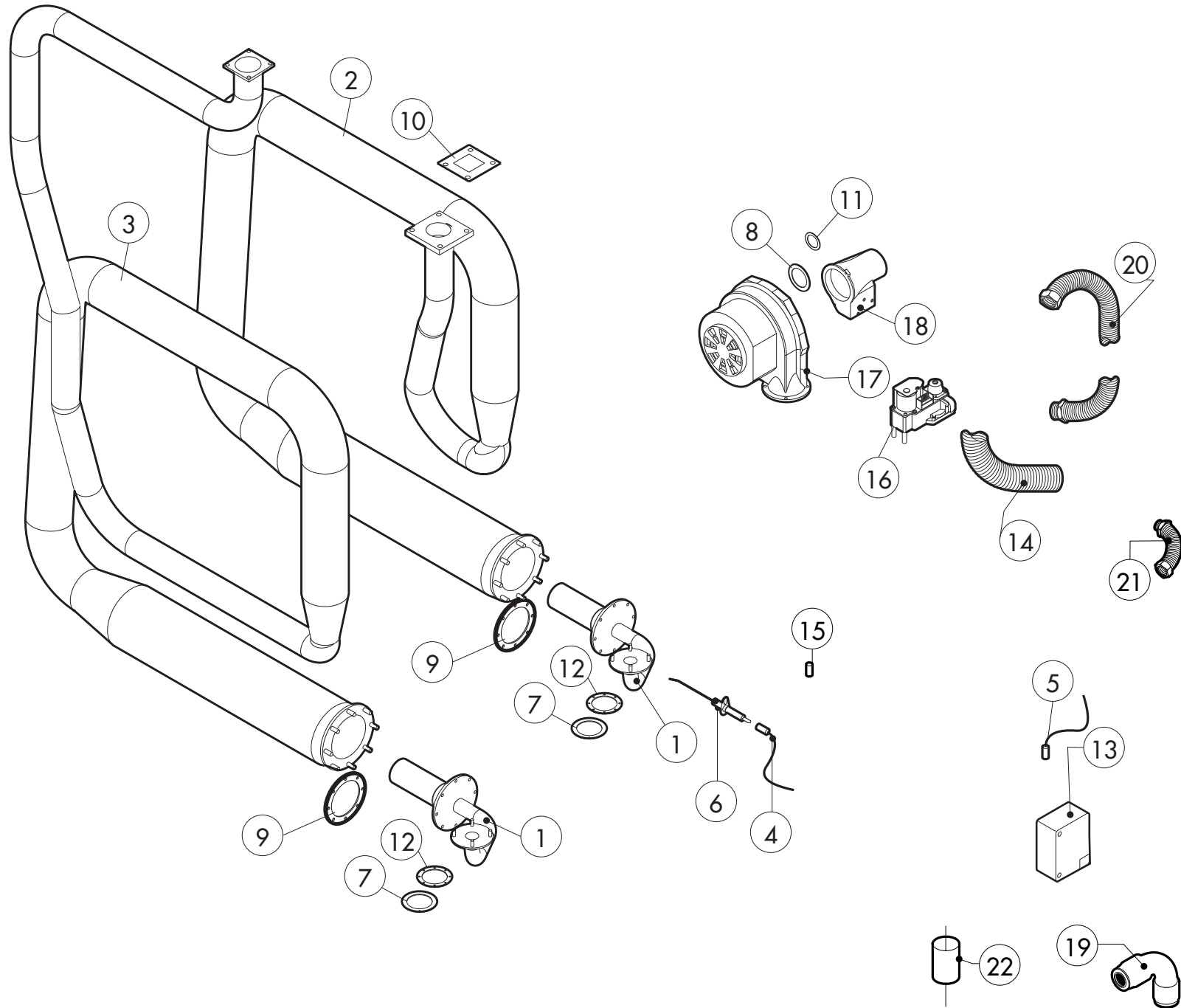

POS.	COD.	Pz.	DESCRIZIONE	DESCRIPTION	DESCRIPTION	BESCHREIBUNG	DESCRIPCIÓN
1	R11218002	2	ASS. BRUCIATORE CAMERA HMG101	COOKING CABINET BURNER	BRÛLEUR MOUFLE	GARRAUMBRENNER	QUEMADOR CAMERA
2	R11208860	1	ASS.SCAMBIATORE.CAM.INF. K_G201	HEAT EXCHANGER ACCESSORIES INCLUDED	ECHANGEUR CHALEUR ET ACCESSOIRES	WÄRMETAUSCHER KOMPLETT MIT ZUBEHÖR	INTERCAMBIADOR COMPLETO CON ACCESORIOS
3	R11208850	1	ASS.SCAMBIATORE.CAM.SUP.K_G201	FLAME IGNITION CABLE/FLAME SENSOR CABLE	DIAPHRAGME (POUR VERSION A GAZ LIQUIDE)	ZUENDKABEL/FLAMMENUEBERWACHUNGSKABEL	CABLE ENCENDIDO/SENSOR
4	R66605821	2	CAVO ACC./RIL.CAM./BOIL. L=300 2 CAVI	FLAME IGNITION CABLE/FLAME SENSOR CABLE	CABLE ALLUMAGE/CONTROLE FLAME	ZUENDKABEL/FLAMMENUEBERWACHUNGSKABEL	CABLE ENCENDIDO/SENSOR
5	R66605140	2	CAVO ACCENS.C/CONNETT.A 90° D.6,3 L=400	FLAME IGNITION CABLE/FLAME SENSOR CABLE	CABLE ALLUMAGE/CONTROLE FLAME	ZUENDKABEL/FLAMMENUEBERWACHUNGSKABEL	CABLE ENCENDIDO/SENSOR
6	R63050130	6	CANDELA ACCENSIONE A/SM ø9.5 KA1 ø3/M4	IGNITOR	BOUGIE ALLUMAGE	ZUENDKERZE	BUJIA ENCENDIDO
7	R11430350	2	DIAFRAMMA VENTILATORE/BRUCIATORE D.18	ORIFICE D.18	DIAPHRAGME D.18	BLLENDE D.18	DIAFRAGMA D.18
8	R58004190	2	DISCO CALIBRATO ø4 mm	ORIFICE D.4	DIAPHRAGME D.4	BLLENDE D.4	DIAFRAGMA D.4
9	R63140080	4	GUARNIZIONE SCAMB.-BRUC. De.126 18-27kW	BURNER/HEAT EXCHANGER GASKET	JOINT BRULEUR / ECHANGEUR CALORIFIQUE	DICHTUNG BRENNER/WARMETAUSCHER	JUNTA QUEMADOR/INTERCAMBIADOR
10	R63140010	4	GUARN.BOIL.-COND.FUMI VM-G/061.	HEAT EXCHANGER GASKET	JOINT ECHANGEUR CALORIFIQUE	DICHTUNG WARMETAUSCHER	JUNTA INTERCAMBIADOR
11	R70050090	2	GUARNIZIONE VALVOLA VENTURI INGRESSO LAT	VENTURI GASKET	JOINT VENTURI	DICHTUNG	JUNTA VENTURI
12	R63140050	2	GUARN. VENTILATORE-BRUCIATORE	BURNER/FAN MOTOR GASKET	JOINT VENTILATEUR / BRULEUR	DICHTUNG GEBLASE/GASBRENNER	JUNTA VENTILADOR/QUEMADOR
13	R65180270	2	TRASF.ACCENS. COFI TRK2-3PVD	IGNITION TRANSFORMER	TRANSFORMATEUR D'ALLUMAGE	ZÜNDTRANSFORMATOR	TRANSFORMADOR DE ENCENDIDO DESDE
14	R77700056	2 mt	TUBO FLEX c/Spirale Di.30 De.35,3 COMAP	AIR INLET FLEXIBLE PIPE	TUBE ASPIRATION AIR	LUFTANSAUGRUHR	TUBO ASPIRACION AIRE
15	R58001480	6	BOCCOLA FISSAGGIO CANDELETTE	BUSH	DOUILLE	BUSCH	CASQUILLO
16	R63020170	2	VALVOLA GAS VK4115 V 1014 HON.	GAS SOLENOID VALVE	VALVE GAZ	GAS VENTIL	VALVULA GAS
17	R65060360	2	VENTILATORE PER BRUCIATORE GAS	GAS BURNER FAN MOTOR	VENTILATEUR POUR BRULEUR GAZ	GEBLASEF.GASBRENNER	VENTILADOR PARA QUEMADOR GAS
18	R63120030	2	VENTURI VALV.GAS.BRUC.PRE-MIX45900446-053	VENTURI TUBE	VENTURI	VENTURIROHR	VENTURI
19	R62280078	2	CURVA POLYPR.HTB DN50 87,5° DIN EN1451-1	CURVE	COURBE	KURVE	CURVA
20	R62180152	1	FLEX GAS L=100 CM M/F1/2" INOX	GAS INLET FLEXIBLE PIPE	TUBE FLEXIBLE ENTREE GAZ	FLEXROHR GASZULAUF	TUBO FLEXIBLE ENTRADA GAS
21	R62180132	1	FLEX GAS L=50 CM M/F1/2" INOX	GAS INLET FLEXIBLE PIPE	TUBE FLEXIBLE ENTREE GAZ	FLEXROHR GASZULAUF	TUBO FLEXIBLE ENTRADA GAS
22	R70060121	2	MANICOTTO RIDUZIONE De.45,5 Di.35 (PA 6)	REDUCTION COUPLING	MANCHON REDUCTION	REDUZIERMUFFE	MANGUITO REDUCCION

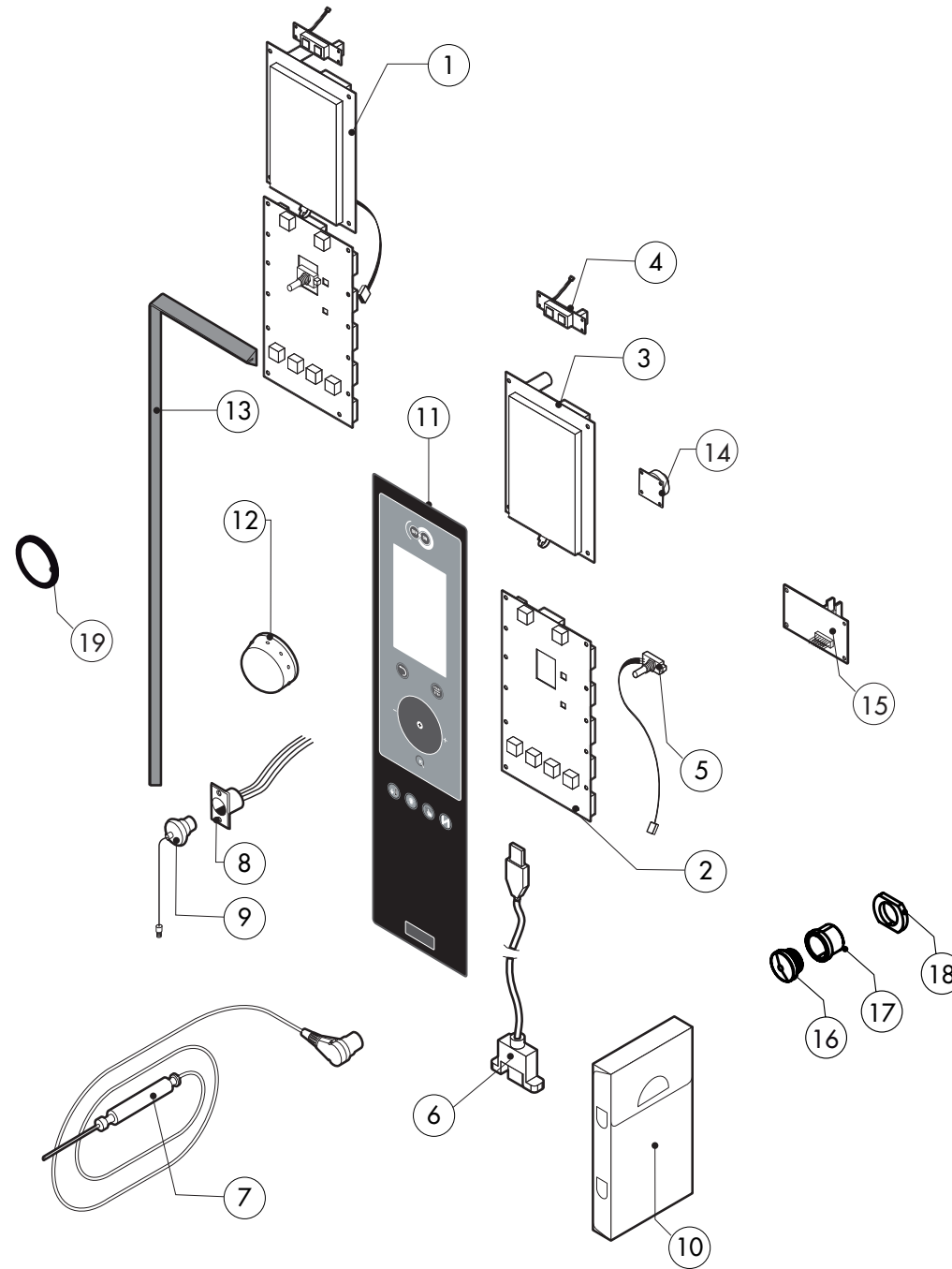

ATTENZIONE: PER TENSIONI SPECIALI, SPECIFICARE SEMPRE IL MODELLO DI FORNO ED IL NUMERO DI MATRICOLA
ATTENTION: FOR SPECIAL VOLTAGES, PLEASE ALWAYS SPECIFY THE OVEN MODEL AND THE SERIAL NUMBER

ATTENTION: POUR TENSIONS SPÉCIALES, MERCI DE SPÉCIFIER TOUJOURS LE MODÈLE DU FOUR ET LE NUMÉRO DE SÉRIE
ACHTUNG: BEI SONDRSPANNUNGEN, BITTE IMMER OFEN-MODELL UND SERIENNUMMER GEBEN.

ed. 0713

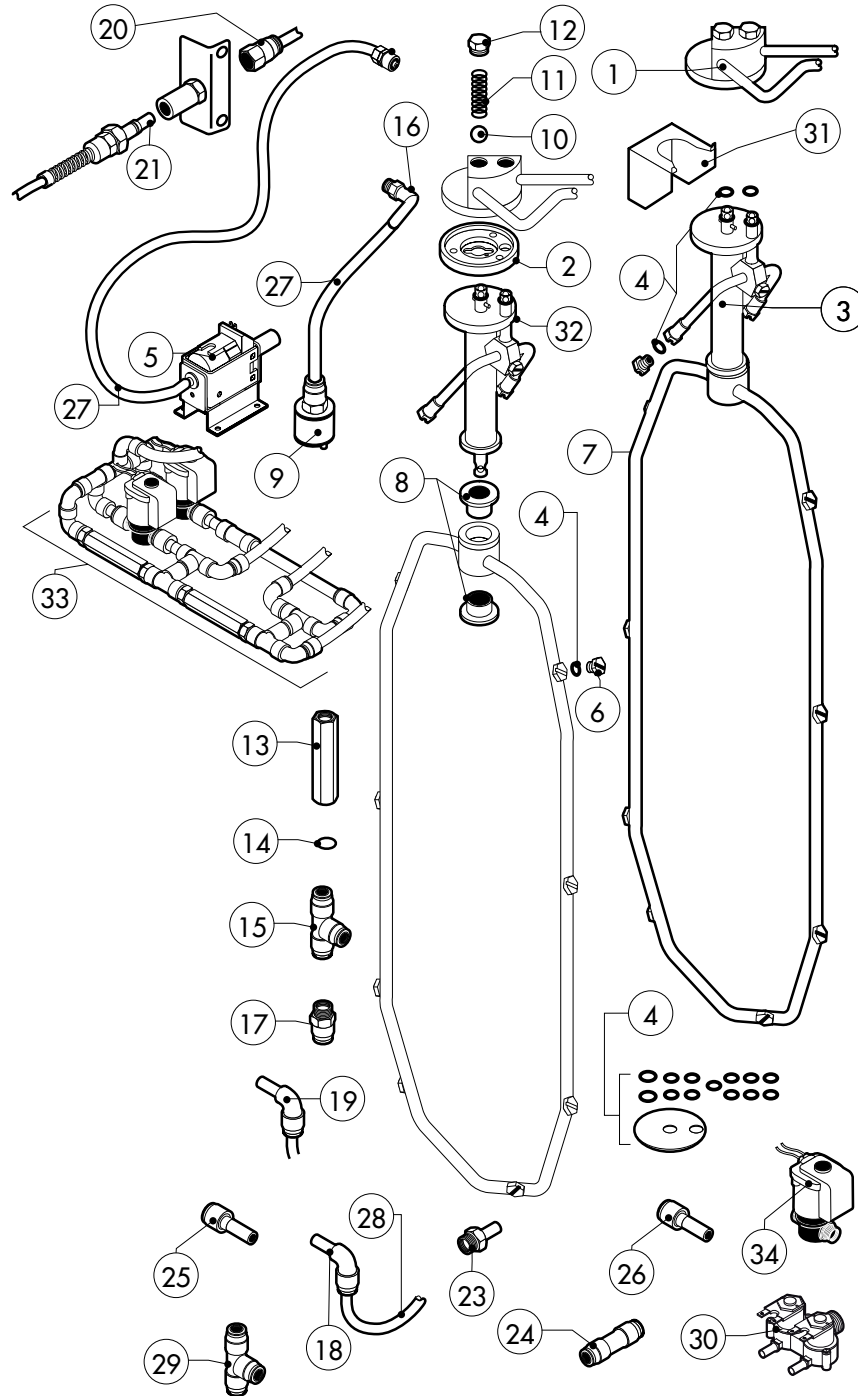
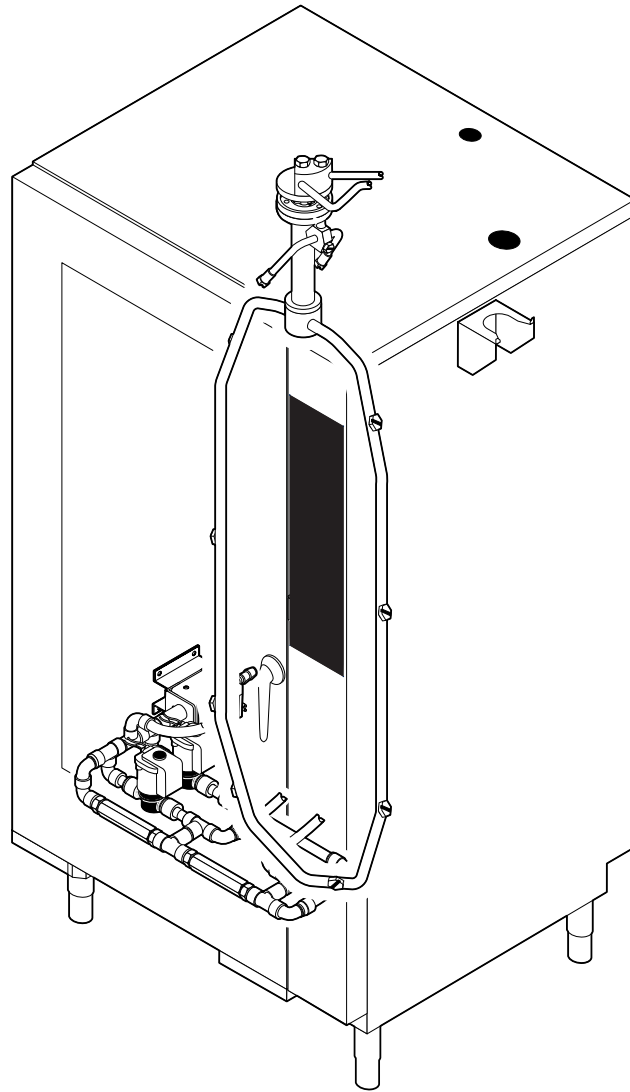

ATTENZIONE: PER ORDINARE I RICAMBI, SPECIFICARE SEMPRE IL MODELLO DI FORNO ED IL NUMERO DI MATRICOLA
ATTENTION: WHEN ORDERING SPARE PARTS, PLEASE ALWAYS SPECIFY THE OVEN MODEL AND THE SERIAL NUMBER

ATTENTION: POUR COMMANDER DES PIÈCES, MERCI DE SPECIFIER TOUJOURS LE MODÈLE DU FOUR ET LE NUMÉRO DE SÉRIE
ACHTUNG: UM ERSATZTEILE ZU BESTELLEN, BITTE IMMER OFEN-MODELL UND SERIENNUMMER GEBEN.

ed. 0713

POS.	COD.	Pz.	DESCRIZIONE	DESCRIPTION	DESCRIPTION	BESCHREIBUNG	DESCRIPCIÓN
1	R11205860	1	BLOCCO ESTERNO LAVAGGIO	WASHING SYSTEM EXTERNAL ASSEMBLY	ENSEMBLE EXTERIEUR DU LAVAGE	EXTERNE WASCHARMBEFESTIGUNG	BLOQUE EXTERNO LAVADO
2	R58004960	1	FLANGIA INTERNA LAVAGGIO	WASHING SYSTEM INNER FLANGE	BRIDE INTERIEUR BRAS DE LAVAGE	INNEN FLANSCH WASCHARMBEFESTIGUNG	PLATINA INTERNA LAVADO
3	R11100530	1	BRACCIO LAVAGGIO COMPLETO	WASHING DEVICE ASSEMBLY	BRAS DE RINCAGE COMPLET	WASHARM KOMPLETT	BRAZO LAVADO COMPLETO
4	R70045100	1	KIT GUARNIZIONI	GASKETS KIT	ENSEMBLE JOINTS	DICHTUNGSSATZ	KIT JUNTAS
5	R65110600	1	POMPA ELETTROM.A PIS.OSC.ET508.	DETRGENT PUMP	POMPE DETERGEANT	REINIGERPUMPE	BOMBA DETERGENTE
6	R62210032	8	UGELLO LAVAGGIO 1,3 L/MIN	1,3 L/MIN RINSING JET	GICLEUR LAVAGE 1,3 LITRE/MINUTE	SPULDUSE REINIGUNG 1,3L/MIN	INYECTOR LAVADO 1,3 L/MIN
7	R62210052	4	UGELLO OVK 110ø 0,30 L/MIN 1,5BAR	0,30 L/MIN DETERGENT JET	GICLEUR DETERGENT 0,30 LITRE/MINUTE	SPULDUSE REINIGER 0,30 L/MIN	INYECTOR DETERGENTE 0,30 L/MIN
8	R58004980	2	BOCCOLA ROTAZIONE BRACCIO LAVAGGIO	WASHING DEVICE ROTATION BUSH	COQUILLE ROTATION BRAS LAVAGE	DEEHBUCHESE F. WASCHARM	CASQUILLO ROTACION BRAZO LAVADO
9	R65110650	1	VALVOLA DI FONDO PER FILTRO GM.060.35	BOTTOM FILTER	FILTER POUR TUBE DETERGEANT	ANSAUGFILTER F. REINIGUNGSSCHAUCH	VÁLVULA DE FONDO TUBO DEL LIMPIADOR
10	R62220012	2	SFERA D. 14	SPHERA D.14	SPHERE D. 14	VERSCHLUSSKUGEL D.14	ESFERA D.14
11	R61620041	2	MOLLA	SPRING	RESSORT	FEDER	MUELLE
12	R58005000	2	TAPPO MASCHIO 1/2"	1/2" MALE COVER	BOUCHON 1/2"	MUTTERSTOPFEN 1/2"	TAPON MACHO 1/2"
13	R65110680	2	VALVOLA ANTIRITORNO J.G. 10SCV	ANTI-BACK FLOW	ANTIRETOUR	RÜCKFLUSSVERHINDERER	ANTIRETORNO
14	R70010050	4	GUARNIZIONE OR 7,60x2,62	JOINT OR 7,60x2,62	OR GASKETS	RINGDICHTUNG 7,60X2,62	VIDRIO OR 7,60x2,62
15	R62090468	5	RACCORDO INTERMEDIO A "T" D.10	T MIDLING PIPE FITTING D.10	RACCORD INTERMEDIAIRE A "T" D.10	MITTELVERBINDUNGSSTÜCK D.10 "T"- FORMIG	RACOR INTERMEDIO TIPO "T" D.10
16	R62090678	2	RACC.A GOMITO C/CODOLO 8X8 PM220808E	ELBOW PIPE FITTING (WITH TANG) 8 X 8	COURBE AVEC QUEUE 8x8	WINKELVERBINDUNGSSTÜCK 8X8 MIT SCHAFT	RACOR DE GOMA CON CODO 8x8
17	R62090688	1	RACC.TERMIN.DIR.FIL.CON.8X1/4 NC2500-P	8x1/4 STRAIGHT THREADED TERMINAL PIPE FITTING	RACCORD FILET DROIT 8x1/4"	ENDVERBINDUNGSSTÜCK 8x1/4" GESCHNITTEN	RACOR TERMINAL DERECHO ROSCADO 8x1/4"
18	R62090528	6	RACCORDO A GOMITO CON CODOLO 10x10	ELBOW PIPE FITTING (WITH TANG) 10 X 10	COURBE AVEC QUEUE 10x10	WINKELVERBINDUNGSSTÜCK 10 X 10 MIT SCHAFT	RACOR DE GOMA CON CODO 10x10
19	R62090808	2	GOMITO CON CODOLO ø6-ø6 PM220606E	8X1/8 END SIDE PIPE FITTING (WITH TANG)	RACCORD AVEC QUEUE 8x1/8"	ENDVERBINDUNGSSTÜCK 8 X 1/8" MOT SCHAFT	RACOR TERMINAL CON CODO 8x1/8"
20	R62090538	1	RACCORDO DIRITTO FEMMINA 1/4" PER TUBO D.8x6	1/4" FEMALE STRAIGHT PIPE FITTING FOR D.6X8 PIPE	RACCORD DROIT PARTIE FEMELLE 1/4" TUBE 6x8	VERBINDUNGSSTÜCK 1/4" WEBL. FÜR ROHR D.6X8	RACOR DERECHO HEMBRA 1/4" PARA TUBO D.6x8
21	R62090482	1	RACCORDO RAPIDO MASCHIO	RAPID MALE PIPE FITTING	RACCORD RAPIDE PARTIE MALE	SCHNELLEVERBINDUNG MANNL	RACOR RAPIDO MACHO
22	R62090638	1	RACC.RAP.FEMM.X LAV.FIL.FEMM PVPU40-F1/4	RAPID FEMALE PIPE FITTING	RACCORD RAPIDE PARTIE FEMELLE	SCHNELLEVERBINDUNG	RACOR RAPIDO HEMBRA
23	R62090608	2	RACCORDO TERMINALE C/CODOLO 8x1/8"	8X1/8 END SIDE PIPE FITTING (WITH TANG)	RACCORD AVEC QUEUE 8x1/8"	ENDVERBINDUNGSSTÜCK 8 X 1/8" MOT SCHAFT	RACOR TERMINAL CON CODO 8x1/8"
24	R62090458	1	RACCORDO INTERMEDIO DRITTO D.10	PIPE FITTING	COURBE	STÜCK	RACOR
25	R62090618	2	RACCORDO DIRITTO RIDUZIONE 10-8	REDUCTION PIPE FITTING	RACCORD DROIT REDUCTION	GERADE ANSCHLUSS-VERKLEINERUNG	RACOR DERECHO REDUCCION
26	R62090548	4	RACCORDO DIRITTO RIDUZIONE 10-6	REDUCTION PIPE FITTING	RACCORD DROIT REDUCTION	GERADE ANSCHLUSS-VERKLEINERUNG	RACOR DERECHO REDUCCION
27	R80150020	2	TUBO PE D.8mm x 6	PIPE	TUBE	LEITUNG	TUBO
28	R80150030	1	TUBO PE D.10mm x 7 (3 MT.)	PIPE	TUBE	LEITUNG	TUBO
29	R62090488	1	RACCORDO INTERMEDIO A "T" D.6 PM0206E	T MIDLING PIPE FITTING	RACCORD INTERMEDIAIRE A "T"	MITTELVERBINDUNGSSTÜCK "T"- FORMIG	RACOR INTERMEDIO TIPO "T"
30	R65110210	1	ELETR. 2 VIE 220V 50HZ X J.G..	SOLENOID VALVE 220V 50HZ WITH FLOW REDUCER	ELECTROVANNE 220V 50HZ AVEC REG.DE DEBIT	MAGNETVENTIL 220V 50HZ MIT DRUCKMINDERER	ELECTROVALVULA DOBLE 220V 50HZ C/ REDUCT.
31	R11402000	1	SUPPORTO ESTERNO BRACCIO LAVAGGIO	WASHING DEVICE EXTERNAL HOLDER	SUPPORT EXTERIEUR BRAS DE LAVAGE	WANDHALTERUNG FÜR WASHARM	SOPORTE EXTERNO BRAZO LAVADO
32	R14102550	1	TUBO SUPPORTO BRACCIO LAVAGGIO T06-M/072	TUBE DEVICE SUPPORT WASHING	TUBE JE SUPPORTE DISPOSITIF LAVAGE	HALTERUNGSRÖHRWASCHRAUM	TUBO SUPORTE BRAZO LAVADO
33	R62300058	1	GRUPPO ANTIRIT.+SVUOT. COND.K_102-072-201	ANTI-BACK FLOW DEVICE ASSEMBLY	GROUPE JE COMPLÈTE ANTI-RETOUR	KOMPLET RÜCKFLUSSVENTIL SATZ	KIT ANTIRETORNO COMPLETO
34	R65110260	2	ELETTROV.SR.7 NA JOHN GUEST D.6 230V50HZ	SOLENOID VALVE D.6 230V 50HZ	ELECTROVANNE D.6 230V 50HZ	MAGNETVENTIL D.6 230V 50HZ	ELECTROVALVULA D.6 230V 50HZ
35	R70070080	1	TUBO GOMMA PER ALIMENTI Di13 De23 L=1MT	PIPE	TUBE	LEITUNG	TUBO

TAV. E

ABG 156 X