

ATTENZIONE: PER TENSIONI SPECIALI, SPECIFICARE SEMPRE IL MODELLO DI FORNO ED IL NUMERO DI MATRICOLA
ATTENTION: FOR SPECIAL VOLTAGES, PLEASE ALWAYS SPECIFY THE OVEN MODEL AND THE SERIAL NUMBER

ATTENTION: POUR TENSIONS SPÉCIALES, MERCI DE SPÉCIFIER TOUJOURS LE MODÈLE DU FOUR ET LE NUMÉRO DE SÉRIE
ACHTUNG: BEI SONDRSPANNUNGEN, BITTE IMMER OFEN-MODELL UND SERIENNUMMER GEBEN.

ed. 0713

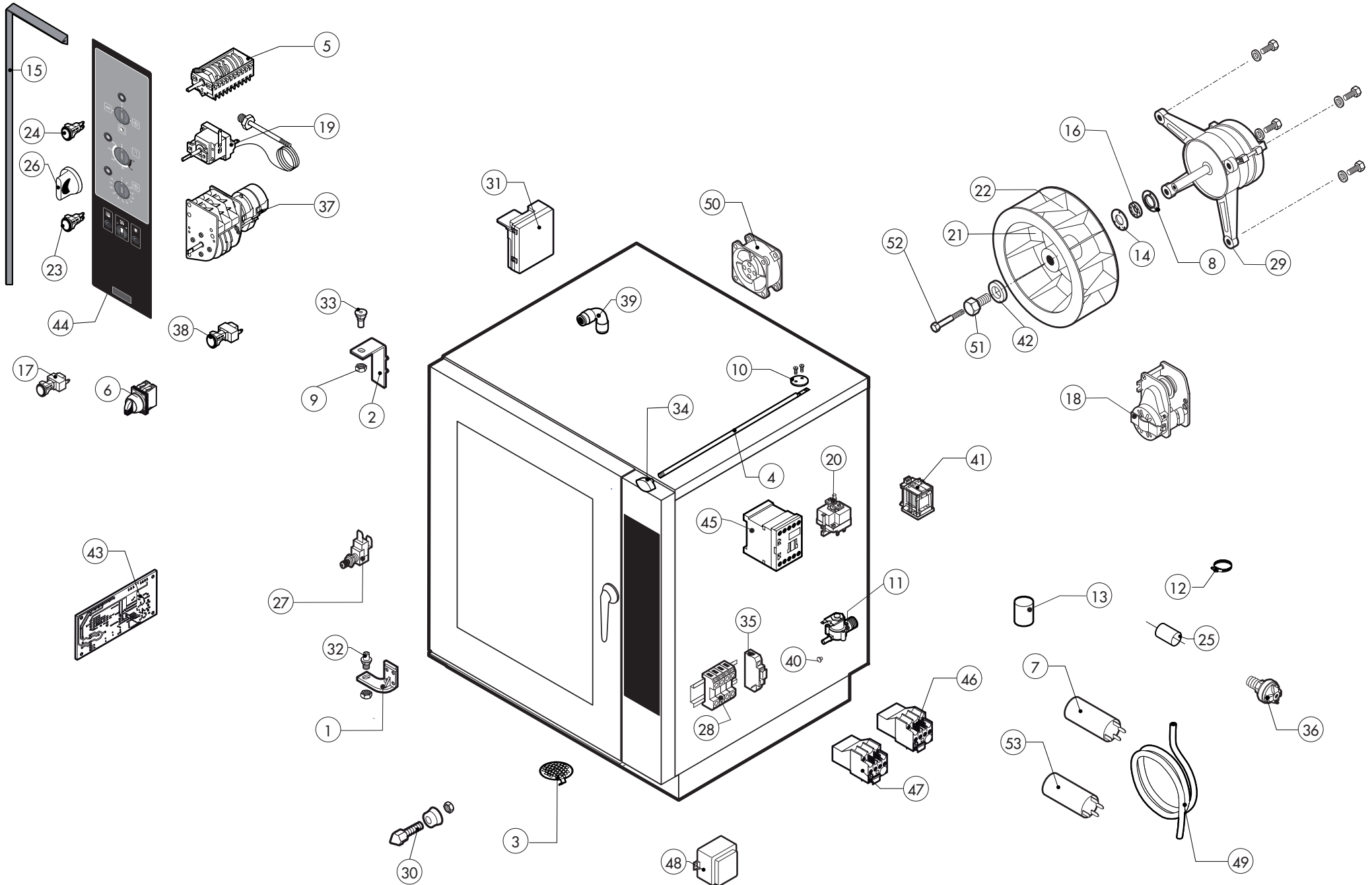

ATTENZIONE: PER ORDINARE I RICAMBI, SPECIFICARE SEMPRE IL MODELLO DI FORNO ED IL NUMERO DI MATRICOLA
ATTENTION: WHEN ORDERING SPARE PARTS, PLEASE ALWAYS SPECIFY THE OVEN MODEL AND THE SERIAL NUMBER

ATTENTION: POUR COMMANDER DES PIÈCES, MERCI DE SPECIFIER TOUJOURS LE MODÈLE DU FOUR ET LE NUMÉRO DE SÉRIE
ACHTUNG: UM ERSATZTEILE ZU BESTELLEN, BITTE IMMER OFEN-MODELL UND SERIENNUMMER GEBEN.

ed. 0713

POS.	COD.	Pz.	DESCRIZIONE	DESCRIPTION	DESCRIPTION	BESCHREIBUNG	DESCRIPCIÓN
1	R18404500	1	ASS. CERNIERA INFERIORE PORTA A07-10-20	LOWER HINGE	CHARNIERE INFERIEUR	UNTERES SCHARNIER	BISAGRA INFERIOR
2	R11426830	1	CERNIERA SUPERIORE PORTA SR.2013	UPPER HINGE	CHARNIERE SUPERIEUR	OBERES SCHARNIER	BISAGRA SUPERIOR
3	R10201700	1	ASS. FILTRO DI SCARICO	DRAIN FILTER	FILTRE ENCEINTE	ABFLUSSFILTER	FILTRO DESAGUE
4	R58007100	1	ASTA SFIATO	CHAMBER VENT ROD	BARRE COMMANDE EVENT	SCHIEBERACHSE	EJE RESPIRADERO
5	R65080010	1	COMMUTATORE	MAIN SELECTOR SWITCH	COMMUTATEUR	HAUPTSCHALTER	CONMUTADOR
6	R65080150	1	COMMUTATORE 2 POSIZIONI	2 POSITIONS SELECTOR SWITCH	COMMUTATEUR 2 POSITIONS	HAUPTSCHALTER 2 POSITIONEN	CONMUTADOR 2 POSICIONES
7	R65190040	1	CONDENSATORE MOTORE 20 µF	CAPACITOR	CONDENSATEUR	KONDENSATOR	CONDENSADOR
8	R58003850	1	CONTROFLANGIA GUARNIZIONE MOTORE	MOTOR GASKET BRASS COUNTER FLANGE	CONTRE- BRIDE JOINT MOTEUR	GEGENFLANSCH F. MOTORDICHTUNG	CONTRABRIDA JUNTA MOTOR
9	R58004050	2	DADO PER PERNO CERNIERA REG. M/106-220	NUT FOR DOOR HINGE	ECROU CHEVILLE CHARNIERE	MUTTER F. SCHARNIERSTIFT	TUERCA PARA PERNO BISAGRA
10	R18400940	2	DISCO SFIATO	CHAMBER VENT PLATE	ENTFEUCHTUNGSSCHIEBER	DISQUE EVENT	DISCO RESPIRADERO
11	R65110200	1	ELETTROVALVOLA 1 VIA 220V 50HZ	SOLENOID VALVE 220V 50HZ	ELECTROVANNE 220V 50HZ	MAGNETVENTIL 220V 50HZ	ELECTROVALVULA 220V 50HZ
12	R61630021	2	FASCETTE ZINCATE 30-45/9	METAL CLAMPS 30-45/9	COLLIER DE SERRAGE 30-45/9	VERZINKTE SCHELLEN 30-45/9	ABRAZADERA 30-45/9
13	R65280230	1	FILTRO ANTIDISTURBO	INTERFERENCE SUPPRESSOR	FILTRE ANTIPARASITES	STOERSCHUTZFILTER	FILTRO
14	R58003840	1	FLANGIA GUARNIZIONE MOTORE	MOTOR GASKET BRASS FLANGE	BRIDE JOINT MOTEUR	FLANSCH F. MOTORDICHTUNG	BRIDA JUNTA MOTOR
15	R70044260	1	GUARNIZIONE CRUSCOTTO	CONTROL PANEL GASKET	ETANCHEITE COMMANDES	DICHTUNG DER BEDIENUNGSBLENDE	JUNTA PANEL DE MANDOS
16	R70020050	1	GUARNIZIONE MOTORE	MOTOR GASKET	GARNITURE MOTEUR	MOTORDICHTUNG	JUNTA MOTOR
17	R65260600	1	INTERRUTTORE COMPLETO	SWITCH	INTERRUPTEUR	HAUPTSCHALTER	INTERRUPTOR
18	R65090190	1	INVERSORE CICLICO 8'	REVERSING SWITCH	INVERSEUR	POLWENDER	INVERSOR CICLICO
19	R65070360	1	KIT TERMOSTATO 0°/300°C	THERMOSTAT 0/300°C	THERMOSTAT 0/300°C	THERMOSTAT 0/300°C	TERMOSTATO 0/300°C
20	R65070350	1	KIT TERMOSTATO SICUREZZA CAMERA F2	THERMOSTAT	THERMOSTAT	THERMOSTAT	TERMOSTATO
21	R75400440	1	KIT VENTOLA Ø 350x114/12 50HZ P.D.	FAN Ø 350x114/12 50HZ P.D.	TURBINE Ø 350x114/12 50HZ P.D.	LUEFTERRAD Ø 350x114/12 50HZ P.D.	PALA VENTILADOR Ø 350x114/12 50HZ P.D.
22	R75400470	1	KIT VENTOLA Ø 350x114/12 60HZ P.D.	FAN Ø 350x114/12 60HZ P.D.	TURBINE Ø 350x114/12 60HZ P.D.	LUEFTERRAD Ø 350x114/12 60HZ P.D.	PALA VENTILADOR Ø 350x114/12 60HZ P.D.
23	R65270150	2	LAMPADA SPIA ARANCIONE	ORANGE INDICATING LIGHT	LAMPE TMOIN ORANGE	ORANGENE KONTROLLAMPE	LAMPARA PILOTO NARANJA
24	R65270160	1	LAMPADA SPIA VERDE	GREEN INDICATING LIGHT	LAMPE TMOIN VERT	GRUENE KONTROLLAMPE	LAMPARA PILOTO VERDE
25	R70060010	1	MANICOTTO SILICONE Ø 30	SILICON SLEEVE Ø 30	SILICONE SLEEVE Ø 30	SILIKONHÜLLE Ø 30	FUNDA DE SILICONA Ø 30
26	R69030170	3	MANOPOLA	KNOB KIT	POIGNEE COMMANDE	DREHKNOFF	PULSADOR MANETA
27	R65260540	1	MICRO PORTA COMPLETO	DOOR SWITCH	MICRO PORTE	TUERSCHALTER	MICRO PUERTA
28	R65220280	1	MORSETTIERA	TERMINAL BOARD	BORNIER	KLEMMLEISTE	REGLETERA
29	R65040540	1	MOTORE KW 055/015 F1 4-6P 3039200-240V I	MOTOR	MOTEUR	MOTOR	MOTOR
30	R69010260	1	NASELLO 1 STEP	DOOR LATCH 1 STEP	GACHE DE PORTE POUR OUVERTURE SIMPLE	SCHLIESSNASE 1 STUFE	NARIZ 1 CIERRE
31	R63060160	1	PANNELLO ACCENSIONE	BURNER IGNITION PANEL	ALLUMEUR GAZ	ZUENDBOX	PANEL DE ENCENDIDO
32	R58002520	1	PERNO INF.CERNIERA REG. V/061-102	LOWER HINGE PIN	CHEVILLE CHARNIERE INFERIEURE	UNTERES SIE SCHARNIERSTIFT	PERNO INFERIOR BISAGRA
33	R58002150	1	PERNO SUP.CERNIERA REG. M/106-220	UPPER HINGE PIN	CHEVILLE CHARNIERE SUPERIEURE	OBERES SCHARNIERSTIFT	PERNO SUPERIOR BISAGRA
34	R69010410	1	POMELLO SFIATO	STEAM OUTLET KNOB	POIGNEE COMMANDE EVENT	POIGNEE COMMANDE EVENT	MANDO RESPIRADERO
35	R65210020	2	PORTAFUSIBILE BARRA DIN	FUSE CARRIER	PORTE-FUSIBLE	SICHERUNGSHALTER	PORTAFUSIBILE
36	R63070010	1	PRESSOSTATO PG 901.61	GAS SAFETY PRESSURE SWITCH	INT.A PRESSION SECURITE-GAZ	DRUCKSCHALTER PG	PRESOSTATO GAS
37	R65090020	1	PROGRAMMATORE	TIMER	MINUTERIE	PROGRAMMZEITSCHALTUHR	PROGRAMADOR
38	R65260420	1	PULSANTE UMIDIFICATORE	HUMIDIFIER PUSH BUTTON	TOUCHE HUMIDIFICATEUR	BESCHWADUNGSDRUCKTASTE	PULSADOR UMIDIFICADOR
39	R62090478	4	RACCORDO INTERMEDIO A GOMITO D.10	ELBOW PIPE FITTING	COURBE AVEC QUEUE	STUCK MIT SCHAFT	RACOR CON CODO
40	R65110510	1	REGOLATORE DI PORTATA 15LT.	1.5 LT/H WATER FLOW REDUCER	REGULATEUR DE DEBIT 15 LT.	DURCHFLOSSMONDERER 15L/STD.	REGULADOR DE CAUDAL 15 LT.
41	R65170100	1	RELE' 240V AC 16A 62.82300308	RELAY	RELAIS	RELAIS	RELE
42	R58004010	1	RONDELLA FISSAGGIO VENTOLA Ø 30/12.5	FAN WASHER Ø 30/12.5	RONDELLE TURBINE Ø 30/12.5	UNTERLEGSCHIEBE Ø 30/12.5	ARANDELA FIJACION TURBINA Ø 30/12.5
43	R63130050	1	SCHEDA CONTROLLO VENTILATORE BRUCIATORE	GAS BURNER FAN MOTOR PCBOARD	FICHE DE CONTROL VENTILATEUR BRULEUR	PLATINE GEBLASEREGLUNG F. GASBRENNER	PLACA ELECTRONICA VENTILADOR QUEMADOR
44	-	1	TASTIERA	PLATE	PLAQUE	BEDIENUNGSFOLIE	TARJETA

TAV. A

ABG 084-104 M

ATTENZIONE: PER TENSIONI SPECIALI, SPECIFICARE SEMPRE IL MODELLO DI FORNO ED IL NUMERO DI MATRICOLA
ATTENTION: FOR SPECIAL VOLTAGES, PLEASE ALWAYS SPECIFY THE OVEN MODEL AND THE SERIAL NUMBER

ATTENTION: POUR TENSIONS SPÉCIALES, MERCI DE SPÉCIFIER TOUJOURS LE MODÈLE DU FOUR ET LE NUMÉRO DE SÉRIE
ACHTUNG: BEI SONDRSPANNUNGEN, BITTE IMMER OFEN-MODELL UND SERIENNUMMER GEBEN.

ed. 0713

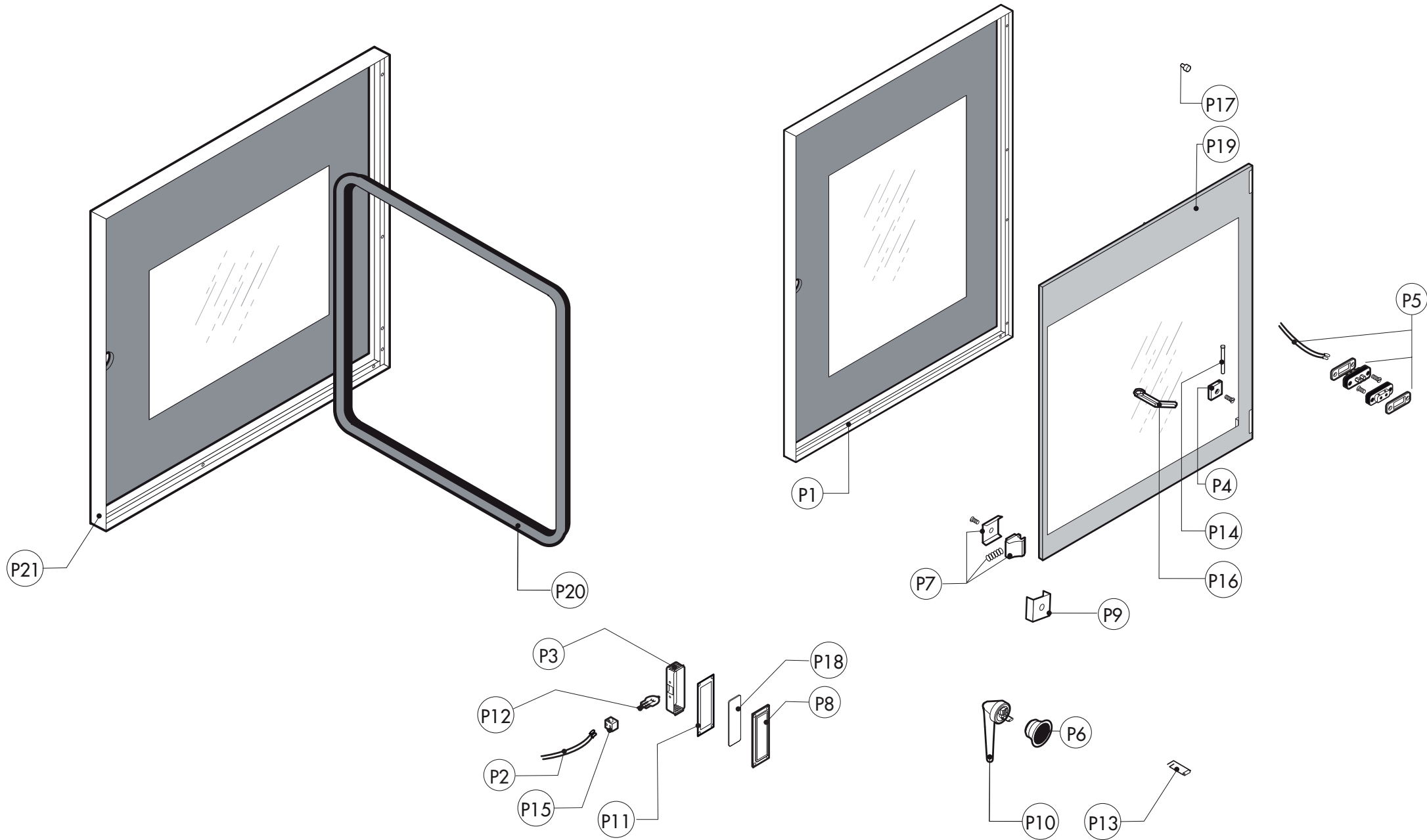

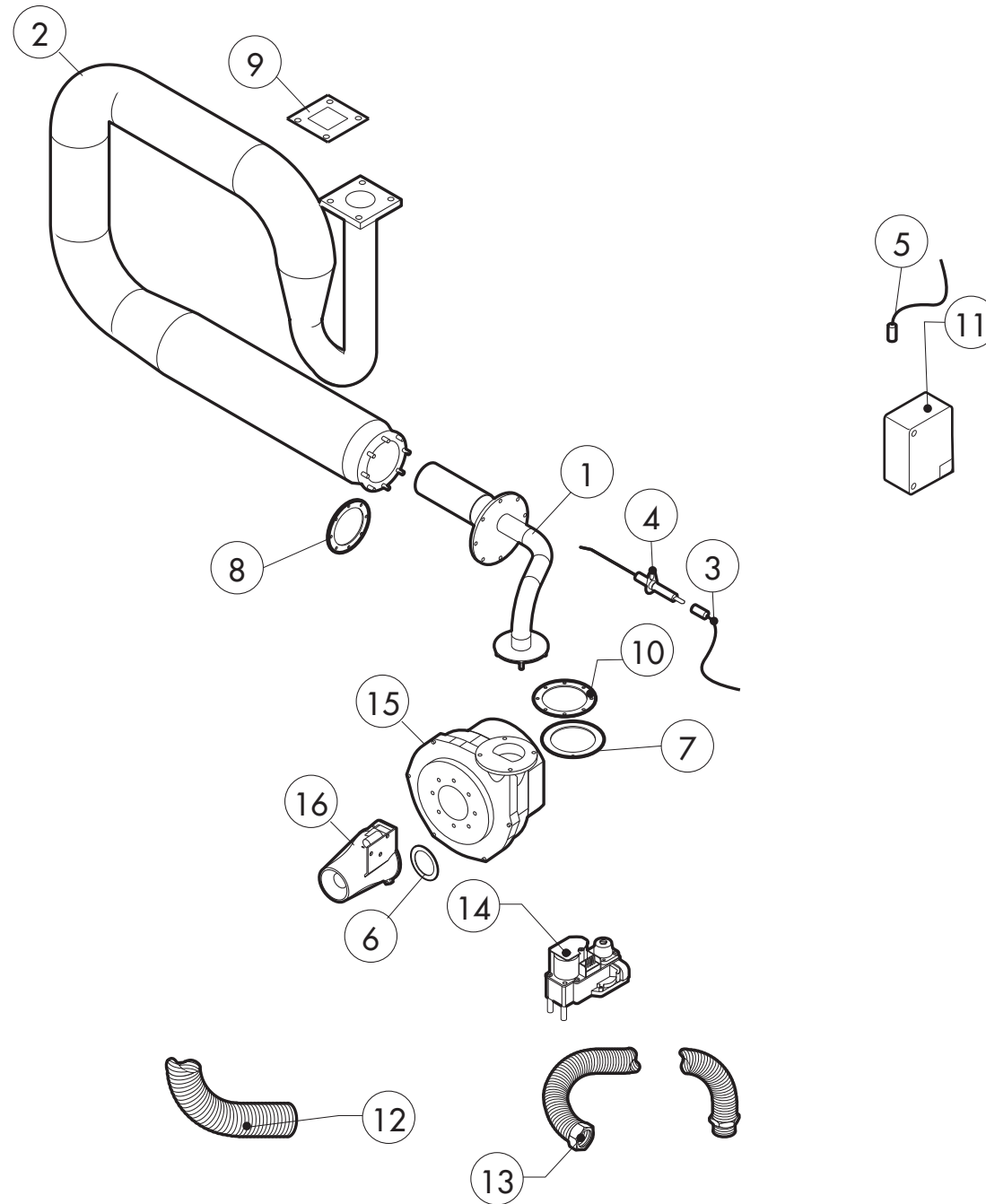

POS.	COD.	Pz.	DESCRIZIONE	DESCRIPTION	DESCRIPTION	BESCHREIBUNG	DESCRIPCIÓN
1	R11218001	1	ASS. BRUCIATORE CAMERA	COOKING CABINET BURNER	BRÛLEUR MOUFLE	GARRAUMBRENNER	QUEMADOR CAMERA
2	R18203120	1	ASS. SCAMBIATORE COMPLETO DI ACCESSORI	HEAT EXCHANGER ACCESSORIES INCLUDED	ECHANGEUR CHALEUR ET ACCESSOIRES	WÄRMETAUSCHER KOMPLETT MIT ZUBEHÖR	INTERCAMBIADOR COMPLETO CON ACCESORIOS
3	R66605821	1	CAVO ACC./RIL.CAM./BOIL. L=300 2 CAVI	FLAME IGNITION CABLE/FLAME SENSOR CABLE	DIAPHRAGME (POUR VERSION A GAZ LIQUIDE)	ZUENDKABEL/FLAMMENEUERWACHUNGSKABEL	CABLE ENCENDIDO/SENSOR
4	R63050130	3	CANDELA ACCENSIONE A/SM ø9.5 KA1 ø3/M4	IGNITOR	BOUGIE ALLUMAGE	ZUENDKERZE	BUJIA ENCENDIDO
5	R66605140	1	CAVO ACCENS.C/CONNETT.A 90° D.6,3 L=400	FLAME IGNITION CABLE/FLAME SENSOR CABLE	CABLE ALLUMAGE/CONTROLE FLAME	ZUENDKABEL/FLAMMENEUERWACHUNGSKABEL	CABLE ENCENDIDO/SENSOR
6	R58004190	1	DISCO CALIBRATO ø4 mm	ORIFICE ø4 mm	DIAPHRAGME ø4 mm	BLENDE ø4 mm	DIAFRAGMA
7	R11430350	1	DIAFRAMMA VENTILATORE/BRUCIATORE D.18	ORIFICE D.18	DIAPHRAGME D.18	BLENDE D.18	DIAFRAGMA D.18
8	R63140080	2	GUARNIZIONE SCAMB.-BRUC. De.84 9kW	BURNER/HEAT EXCHANGER GASKET	JOINT BRULEUR / ECHANGEUR CALORIFIQUE	DICHTUNG BRENNER/WARMETAUSCHER	JUNTA QUEMADOR/INTERCAMBIADOR
9	R63140010	2	GUARN.BOIL.-COND.FUMI VM-G/061	STEAM GENERATOR /HEAT EXCHANGER GASKET	JOINT CHAUDIERE / ECHANGEUR CALORIFIQUE	DICHTUNG DAMPFERZEUGER/WARMETAUSCHER	JUNTA BOILER/INTERCAMBIADOR
10	R63140050	2	GUARNIZIONE VENTILATORE BRUCIATORE	BURNER/FAN MOTOR GASKET	JOINT VENTILATEUR / BRULEUR	DICHTUNG GEBLASE/GASBRENNER	JUNTA VENTILADOR/QUEMADOR
11	R65180270	1	TRASF.ACCENS. COFI TRK2-3PVD	IGNITION TRANSFORMER	TRANSFORMATEUR D'ALLUMAGE	ZÜNDTRANSFORMATOR	TRANSFORMADOR DE ENCENDIDO DESDE
12	R77700056	1 mt	TUBO FLEX c/Spirale Di.30 De.35,3 COMAP	AIR INLET FLEXIBLE PIPE	TUBE ASPIRATION AIR	LUFTANSAUGRUHR	TUBO ASPIRACION AIRE
13	R62180082	1	TUBO FLESSIBILE ENTRATA GAS	GAS INLET FLEXIBLE PIPE	TUBE FLEXIBLE ENTREE GAZ	FLEXROHR GASZULAUF	TUBO FLEXIBLE ENTRADA GAS
14	R63020170	1	VALVOLA GAS VK4115 V 1014 HON.	GAS SOLENOID VALVE	VALVE GAZ	GAS VENTIL	VALVULA GAS
15	R65060360	1	VENTILATORE RG128/1300-3612-020203	GAS BURNER FAN MOTOR	VENTILATEUR POUR BRULEUR GAZ	GEBLASEF.GASBRENNER	VENTILADOR PARA QUEMADOR GAS
16	R63120030	1	VENTURI VAL. GAS. BRUC. PREMIX45900446-055B	VENTURI TUBE	VENTURI	VENTURIROHR	VENTURI