

ATTENZIONE: PER TENSIONI SPECIALI, SPECIFICARE SEMPRE IL MODELLO DI FORNO ED IL NUMERO DI MATRICOLA
ATTENTION: FOR SPECIAL VOLTAGES, PLEASE ALWAYS SPECIFY THE OVEN MODEL AND THE SERIAL NUMBER

ATTENTION: POUR TENSIONS SPÉCIALES, MERCI DE SPÉCIFIER TOUJOURS LE MODÈLE DU FOUR ET LE NUMÉRO DE SÉRIE
ACHTUNG: BEI SONDRSPANNUNGEN, BITTE IMMER OFEN-MODELL UND SERIENNUMMER GEBEN.

ed. 0713

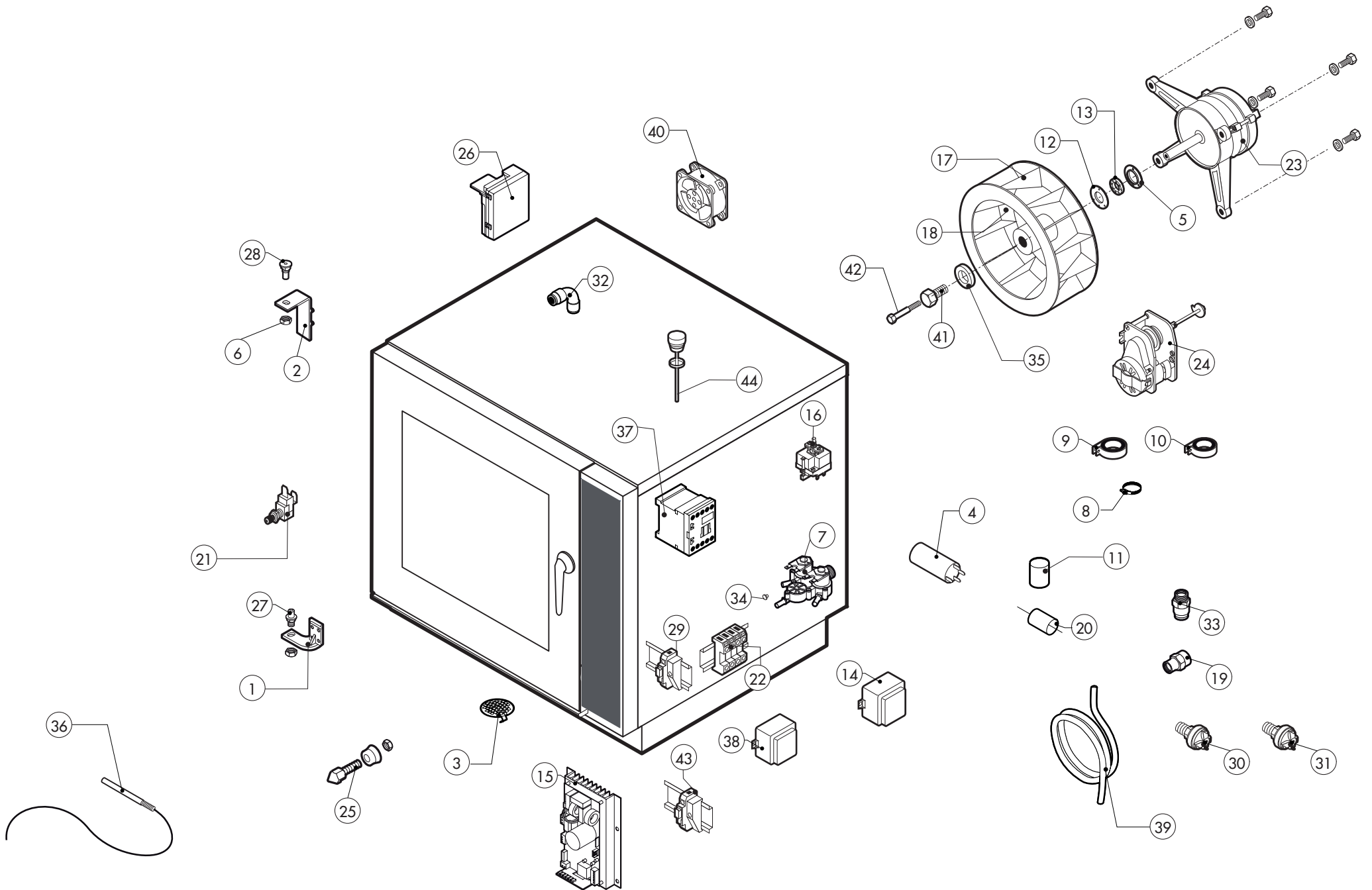

ATTENZIONE: PER ORDINARE I RICAMBI, SPECIFICARE SEMPRE IL MODELLO DI FORNO ED IL NUMERO DI MATRICOLA
ATTENTION: WHEN ORDERING SPARE PARTS, PLEASE ALWAYS SPECIFY THE OVEN MODEL AND THE SERIAL NUMBER

ATTENTION: POUR COMMANDER DES PIÉCES, MERCI DE SPECIFIER TOUJOURS LE MODELE DU FOUR ET LE NUMERO DE SERIE
ACHTUNG: UM ERSATZTEILE ZU BESTELLEN, BITTE IMMER OFEN-MODELL UND SERIENNUMMER GEBEN.

ed. 0713

POS.	COD.	Pz.	DESCRIZIONE	DESCRIPTION	DESCRIPTION	BESCHREIBUNG	DESCRIPCIÓN
1	R18404500	1	ASS. CERNIERA INFERIORE PORTA A07-10-20	LOWER HINGE	CHARNIERE INFERIEUR	UNTERES SCHARNIER	BISAGRA INFERIOR
2	R11426830	1	CERNIERA SUPERIORE PORTA SR.2013	UPPER HINGE	CHARNIERE SUPERIEUR	OBERES SCHARNIER	BISAGRA SUPERIOR
3	R10201700	1	ASS. FILTRO DI SCARICO	DRAIN FILTER	FILTRE ENCEINTE	ABFLUSSFILTER	FILTRO DESAGUE
4	R65190180	1	CONDENSATORE MOTORE 10 µF	CAPACITOR	CONDENSATEUR	KONDENSATOR	CONDENSADOR
5	R58003850	1	CONTROFLANGIA GUARNIZIONE MOTORE	MOTOR GASKET BRASS COUNTER FLANGE	CONTRE- BRIDE JOINT MOTEUR	GEGENFLANSCH F. MOTORDICHTUNG	CONTRABRIDA JUNTA MOTOR
6	R58004050	2	DADO PER PERNO CERNIERA REG. M/106-220	NUT FOR DOOR HINGE	ECROU CHEVILLE CHARNIERE	MUTTER F. SCHARNIERSTIFT	TUERCA PARA PERNO BISAGRA
7	R65110230	1	ELETTROVALVOLA 2 VIE 220V 50HZ	SOLENOID VALVE 220V 50HZ	ELECTROVANNE 220V 50HZ	MAGNETVENTIL 220V 50HZ	ELECTROVALVULA 220V 50HZ
8	R61630021	2	FASCETTE ZINCATE 30-45/9	METAL CLAMPS 30-45/9	COLLIER DE SERRAGE 30-45/9	VERZINKTE SCHELLEN 30-45/9	ABRAZADERA 30-45/9
9	R65280490	1	FERRITE FT36	FERRITE FT36	FERRITE FT36	FERRIT FT36	FERRITA FT36
10	R65280480	1	FERRITE TOROIDALE FT25	FERRITE FT25	FERRITE FT25	FERRIT FT25	FERRITA FT25
11	R65280230	1	FILTRO ANTIDISTURBO	INTERFERENCE SUPPRESSOR	FILTRE ANTIPARASITES	STOERSCHUTZFILTER	FILTRO
12	R58003840	1	FLANGIA GUARNIZIONE MOTORE	MOTOR GASKET BRASS FLANGE	BRIDE JOINT MOTEUR	FLANSCH F. MOTORDICHTUNG	BRIDA JUNTA MOTOR
13	R70020050	1	GUARNIZIONE MOTORE	MOTOR GASKET	GARNITURE MOTEUR	MOTORDICHTUNG	JUNTA MOTOR
14	R65450200	1	INDUTTANZA 6,5 mH 8A	INDUCTANCE	INDUCTANCE	INDUKTANZ	INDUCTANCIA
15	R65140830	1	INVERTER 0.8KW C/SER+DIG+FIL-A002M008XSB	INVERTER	INVERSEUR	INVERTER	INVERSOR
16	R65070350	1	KIT TERMOSTATO SICUREZZA CAMERA F2	THERMOSTAT	THERMOSTAT	THERMOSTAT	TERMOSTATO
17	R75400480	1	KIT VENTOLA Ø 270X114/12 50HZ P.D.	FAN Ø 270X114/12 50HZ P.D.	TURBINE Ø 270X114/12 50HZ P.D.	LUEFTERRAD Ø 270X114/12 50HZ P.D.	PALA VENTILADOR Ø 270X114/12 50HZ P.D.
18	R75400540	1	KIT VENTOLA Ø 270X114/16 60HZ P.D. H=24	FAN Ø 270X114/16 60HZ P.D. H=24	TURBINE Ø 270X114/16 60HZ P.D. H=24	LUEFTERRAD Ø 270X114/16 60HZ P.D. H=24	PALA VENTILADOR Ø 270X114/16 60HZ P.D. H=24
19	R62030118	1	MANICOTTO RIDUZIONE FEMMINA 1/8"-1/4"	1/8"-1/4" FEMALE REDUCTION COUPLING	MANCHON REDUCTION 1/8" - 1/4"	REDUZIERMUFFE 1/8" - 1/4" F	MANGUITO REDUCCION HEMBRA 1/8"-1/4"
20	R70060040	1	MANICOTTO SILICONE Ø 50X3 .	SILICON SLEEVE	SILICONE SLEEVE	SILIKONHÜLLE	FUNDA DE SILICONA
21	R65260540	1	MICRO PORTA COMPLETO	DOOR SWITCH	MICRO PORTE	TUERSCHALTER	MICRO PUERTA
22	R65220280	1	MORSETTIERA	TERMINAL BOARD	BORNIER	KLEMMLEISTE	REGLETERA
23	R65040530	1	MOTORE KW 055 F3 4P 3039 200-440V I	MOTOR	MOTEUR	MOTOR	MOTOR
24	R65095000	1	MOTORINO SFIATO COMPLETO	DAMPER SYSTEM	SORTIE EVAPORATION MOUFLE	DAMPFABLASS-STELLMOTOR	MOTOR RESPIRADERO COMPLETO
25	R69010260	1	NASELLO 1 STEP	DOOR LATCH 1 STEP	GACHE DE PORTE POUR OUVERTURE SIMPLE	SCHLIESSNASE 1 STUFE	NARIZ 1 CIERRE
26	R63060160	1	PANNELLO ACCENSIONE	BURNER IGNITION PANEL	ALLUMEUR GAZ	ZUENDBOX	PANEL DE ENCENDIDO
27	R58002520	1	PERNO INF.CERNIERA REG. V/061-102	LOWER HINGE PIN	CHEVILLE CHARNIERE INFERIEURE	UNTERES SIE SCHARNIERSTIFT	PERNO INFERIOR BISAGRA
28	R58002150	1	PERNO SUP.CERNIERA REG. M/106-220	UPPER HINGE PIN	CHEVILLE CHARNIERE SUPERIEURE	OBERES SCHARNIERSTIFT	PERNO SUPERIOR BISAGRA
29	R65210020	4	PORTAFUSIBILE BARRA DIN 5x20	FUSE CARRIER	PORTE-FUSIBLE	SICHERUNGSHALTER	PORTAFUSIBILE
30	R63070050	1	PRESSOSTATO ACQUA 1/8" 0,5-0,35 BAR	WATER SAFETY PRESSURE SWITCH	INT.A PRESSION SEC.-EAU	WASSER-DRUCKWACHTER	PRESOSTATO AQUA
31	R63070010	1	PRESSOSTATO PG 901.61	GAS SAFETY PRESSURE SWITCH	INT.A PRESSION SECURITE-GAZ	DRUCKSCHALTER PG	PRESOSTATO GAS
32	R62090478	4	RACCORDO INTERMEDIO A GOMITO D.10	ELBOW PIPE FITTING	COURBE AVEC QUEUE	STUCK MIT SCHAFT	RACOR CON CODO
33	R62090508	2	RACCORDO TERM. DIR. FILETTATO 10x1/4"	STRAIGHT THREADED TERMINAL PIPE FITTING	RACCORDEMENT	ENDVERBINDUNGSSTUCK GESCHNITTEN	RACOR
34	R65110510	1	REGOLATORE DI PORTATA 1.5 LT.	1.5 LT/H WATER FLOW REDUCER	REGULATUER DE DEBIT 1.5 LT.	DURCHFLUSSMONDERER 1.5 L/STD.	REGULADOR DE CAUDAL 1.5 LT.
35	R61400052	1	RONDELLA FISSAGGIO VENTOLA Ø 21/10.5	FAN WASHER Ø 21/10.5	RONDELLE TURBINE Ø 21/10.5	UNTERLEGSSCHEIBE Ø 21/10.5	ARANDELA FIJACION TURBINA Ø 21/10.5
36	R65320220	1	SONDA "K" 6X80 1,5 ML TESTA RASTREM.20mm	PROBE "K" 6X80 1,5ML.	SONDE "K" 6X80 1,5ML.	FUEHLER "K" 6X80 1,5ML.	SONDA "K" 6X80 1,5ML.
37	R65140700	1	TELERUTTORE DIL M9-01 4KW-20A MOELLER	CONTACTOR	CONTACTEUR	SCHUETZ	CONTACTOR
38	R65180420	3	TRASFORMATORE 20VA	TRANSFORMER	TRANSFORMATEUR	TRANSFORMATOR	TRANSFORMADOR
39	R70070050	3 m	TUBO FLESSIBILE ACQUA PE D.10mm X 7	WATER FLEXIBLE PIPE	TUYAU FLEXIBLE EAU	WASSERFLEXROHRLEITUNG	TUBO FLEXIBILE AGUA
40	R65060050	2	VENTILATORE COMPATTO D.120	COMPONENTS VENTILATION MOTOR	MOTEUR DE REFRROIDISSEMENT	ABKÜLUNGS MOTOR	MOTOR DE ENFRIAMIENTO
41	R58004000	2	VITE FISSAGGIO VENTOLA M12x1.5 SX	FAN SCREW M12x1.5 SX	VIS DE BLOCAGE TURBINE M12x1.5 SX	VENTILATORSCHRAUBE M12x1.5 SX	TORNILLO FIJACION TURBINA M12x1.5 SX
42	R61020562	2	VITE MOTORE TE A2 M6x55	MOTOR SCREW TE A2 M6x55	VIS DE BLOCAGE MOTEUR TE A2 M6x55	MOTORSCHRAUBE TE A2 M6x55	TORNILLO MOTOR TE A2 M6x55
43	R65210050	1	PORTAFUSIBILE BARRA DIN 6,3x32	FUSE CARRIER	PORTE-FUSIBLE	SICHERUNGSHALTER	PORTAFUSIBILE
44	R10100140	1	TAPPO SFIATO COMPLETO M/106-220	COVER	BOUCHON	ABDECKUNG	TAPON

TAV. A

ABG 064-074 X

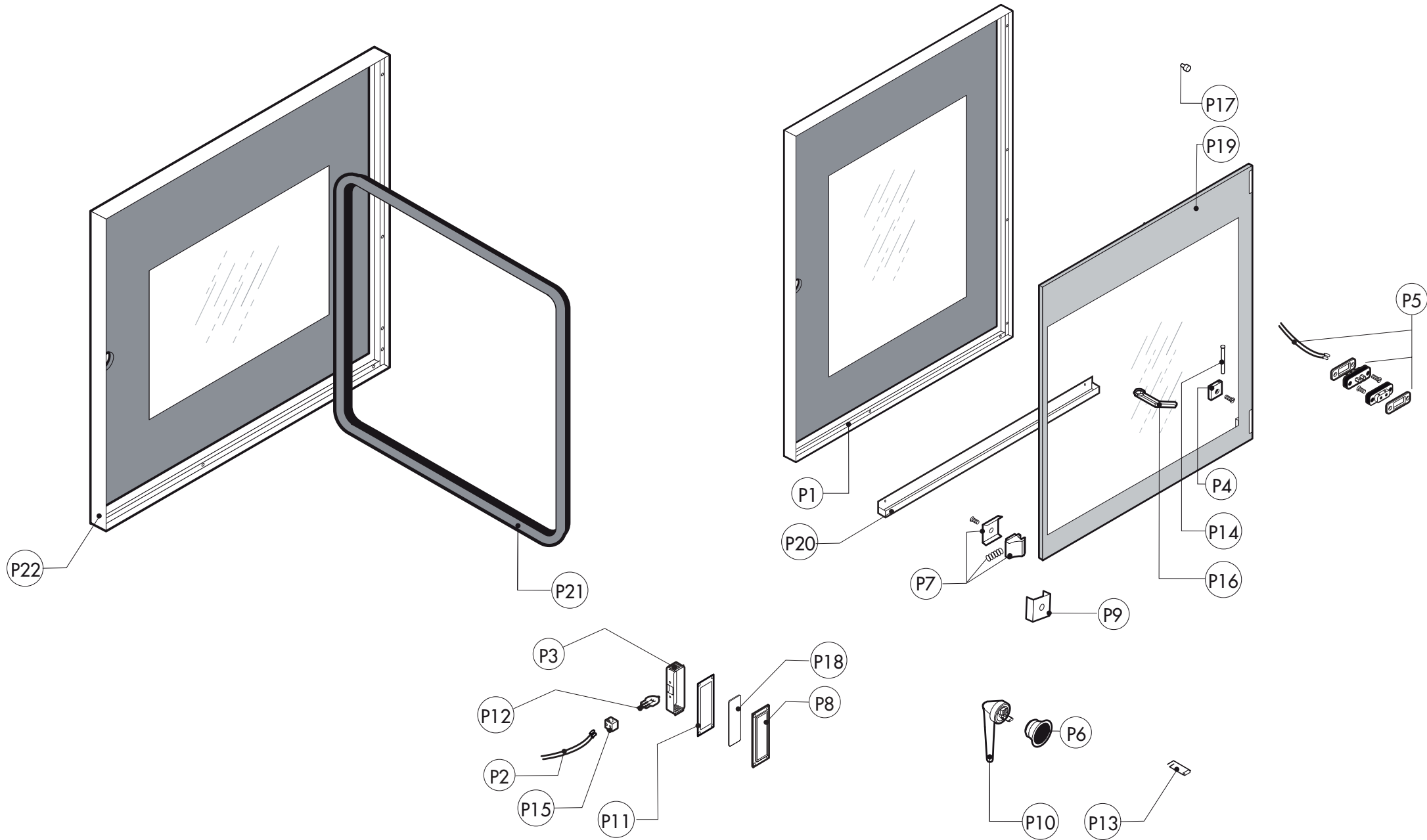

ATTENZIONE: PER ORDINARE I RICAMBI, SPECIFICARE SEMPRE IL MODELLO DI FORNO ED IL NUMERO DI MATRICOLA
ATTENTION: WHEN ORDERING SPARE PARTS, PLEASE ALWAYS SPECIFY THE OVEN MODEL AND THE SERIAL NUMBER

ATTENTION: POUR COMMANDER DES PIECES, MERCI DE SPECIFIER TOUJOURS LE MODELE DU FOUR ET LE NUMERO DE SERIE
ACHTUNG: UM ERSATZTEILE ZU BESTELLEN, BITTE IMMER OFEN-MODELL UND SERIENNUMMER GEBEN.

ed. 0713

POS.	COD.	Pz.	DESCRIZIONE	DESCRIPTION	DESCRIPTION	BESCHREIBUNG	DESCRIPCIÓN
P1	R18203290	1	PORTA ESTERNA A_064	EXTERNAL DOOR	PORTE D'EXTERNAL	AUSSENTÜR	PUERTA EXTERNA
P2	R66110320	1	CABLAGGIO LUCI PORTA MV101-102	DOOR LAMPS CABLE SET	CABLES ECLAIRAGE PORTE	VERDRAHTUNG TURBELEUCHTUNG	CABLEADO LUCES PUERTA
P3	R11401440	1	CALOTTA LAMPADA SR.2000	LAMP COVER	CALOTTE DE PROJECTEUR	LAMPENKALOTTE	CUBIERTA LAMPARA
P4	R58001760	2	CERNIERA FISSA VETRO SR2000	INNER GLASS SOLID HINGE	CHARNIERE VERRE INTERIEUR	SCHARNIER F. INNENSCHIEBE	BISAGRA FIJA VIDRIO INTERNO
P5	R65260750	1	CONTATTO PER LUCI SR.2000	LAMPS CONTACT BLOCK	CONTACT ECLAIRAGE	LICHTKONTSCHALTER	CONTACTO PARA LUZ
P6	R69010630	1	COP.INT.MECC.CHIUS.GRUPPO 6303	DOOR HANDLE	POIGNEE DE PORTE	GRIFFKORPUS	CUERPO MANETA
P7	R58001780	2	FERMO VETRO PORTA P2000	INNER GLASS CATCH KIT	ENSEMBLE ARRET VERRE INTERIEUR	VERSCHLUSSSATZ F. INNENSCHIEBE	KIT FIJACION VIDRIO INTERNO
P8	R11401450	1	FLANG.STAMP.VETRO LAMP. SR2000	GLASS HOLDER LAMP FLANGE	BRIDE ARRET-VERRE ECLAIRAGE	FLANSH F.LAMPENVERGLASUNG	TAPA CRISTAL LAMPARA
P9	R11401350	2	FLANGIA POSTER.VETRO PORTA 061	OUTER DOOR GLASS FLANGE	BRIDE VERRE EXTERIEUR PORTE	FLANSCH ÄUßERE TÜRGLAS	TAPA VIDRIO EXTERNO PUERTA
P10	R69010220	1	GRUP.CHIU.BASC.C/AN.CROM.6303-GRIGIO-STD	DOOR CATCH KIT	ENSAMBLE FERMETURE PORTE	VERSCHLUSSSATZ	MANIJA DE LA PUERTA
P11	R70044200	1	GUARNIZIONE VETRO LAMPADA P2000	LAMP GASKET	JOINT VERRE ECLAIRAGE	LAMPENDICHTUNG	JUNTA VIDRIO CUBRELAMPARA
P12	R65270020	1	LAMPADA ALOGENA 20W 12V G449040	LIGHT 20W 12V G4	LAMPE 20W 12V G4	LAMPENHALTERUNG	LAMPARA HALOGENA 20W 12V G4
P13	R61620132	1	MOLLA AGGANCIO NASELLO 6303.0050A	DOOR LOCK SPRING	RESSORT DE FERMETURE PORTE	TÜR SCHLUSSFEDER	MULLE DE ENGANCHE A TRINQUET
P14	R58001770	2	PERNO CERNIERA VETRO SR2000	INNER GLASS HINGE PIN	PIVOT CHARNIERE VERRE INTERIEUR	SCHARNIERBOLZEN F. INNENSCHIEBE	PERNO BISAGRA VIDRIO INTERNO
P15	R65270450	1	PORTAL. STUCCHI ART.216	LIGHT SOCKET	DOUILLE	LICHTKONTSCHALTER	PORTALAMPARA PARA LAMPARA HALOGENA
P16	R69180010	1	SCARICO BACIN. PORTA DADO ALTO 2009	DOOR DRIP TRAY DRAINAGE	VIDANGE GOUTTIERE SOUS PORTE	ABLAUF TÜRTROPFWANNE	DESAGÜE BANDEJA PUERTA
P17	R70050100	6	TASSELLO BATTUTA VETRO SR.2000	TASSELLO BATTUTA VETRO SR.2000	DOOR CATCH KIT	ENSAMBLE FERMETURE PORTE	VERSCHLUSSSATZ
P18	R71500150	1	VETRO LAMPADA P2000	GLASS LAMP	VERRE PROTECTION LAMPE	LAMPEGLAS	VIDRIO LAMPARA
P19	R71201690	1	VETRO POST. PORTA E_064 705X640X6	DOOR GLASS	VITRE PORTE	HARTGLASS	VIDRIO
P20	R18420831	1	BACINELLA PORTA E_064-084	DRIP TRAY	PLATEAU D'ÉGOUTTEMENT	WASSERTROPFTASSE	BANDEJA DEL GOTEO
P21	R70044850	1	GUARNIZIONE FACCIATA FORNO	FRONT GASKET	JOINT FACADE	DICHTUNG DER FRONTSEITE	JUNTA FRONTAL
P22	R18100531	1	PORTA COMPLETA	DOOR ASSEMBLY	PORTE COMPLETE	TUER KOMPLETT	PUERTA COMPLETA

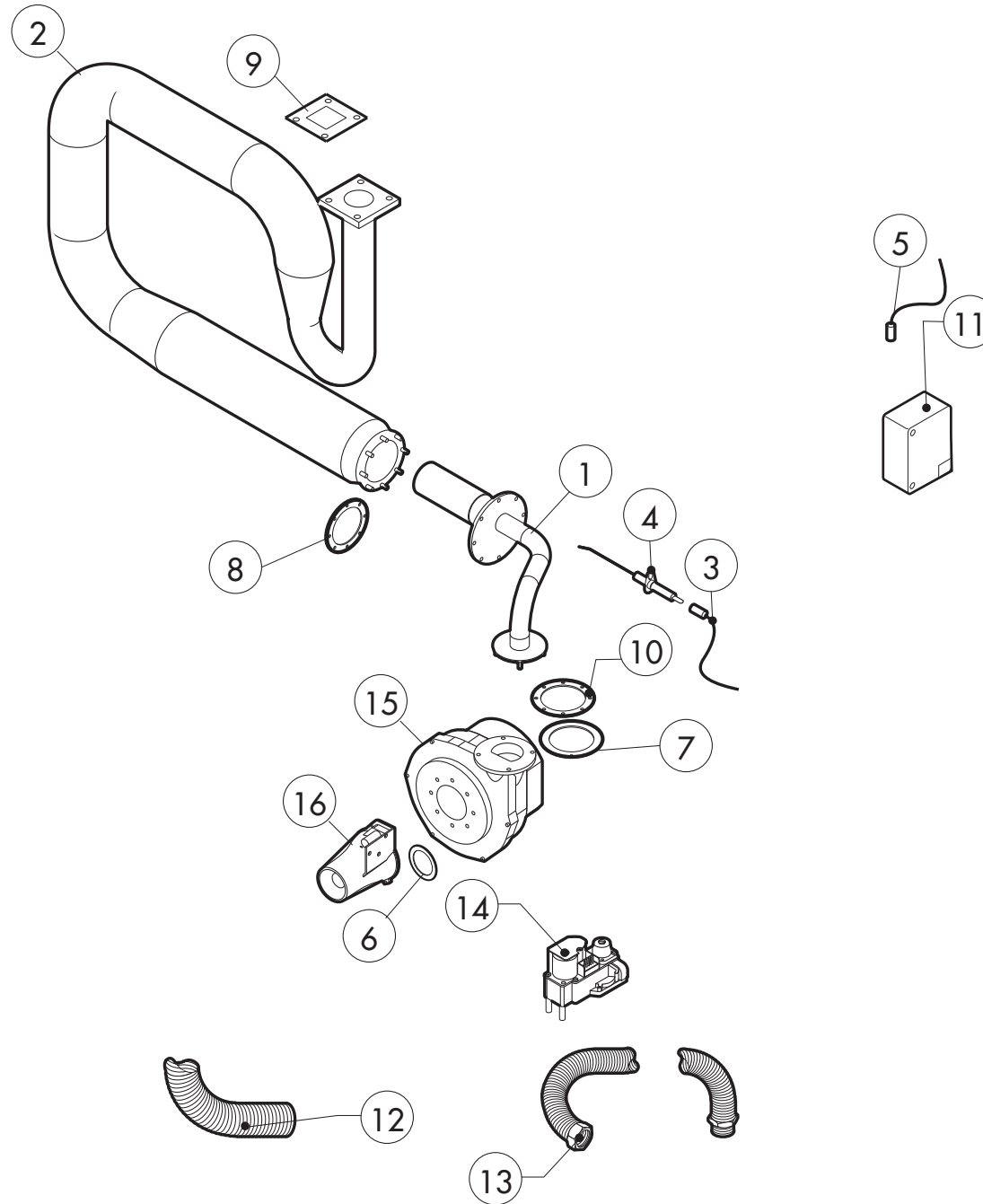

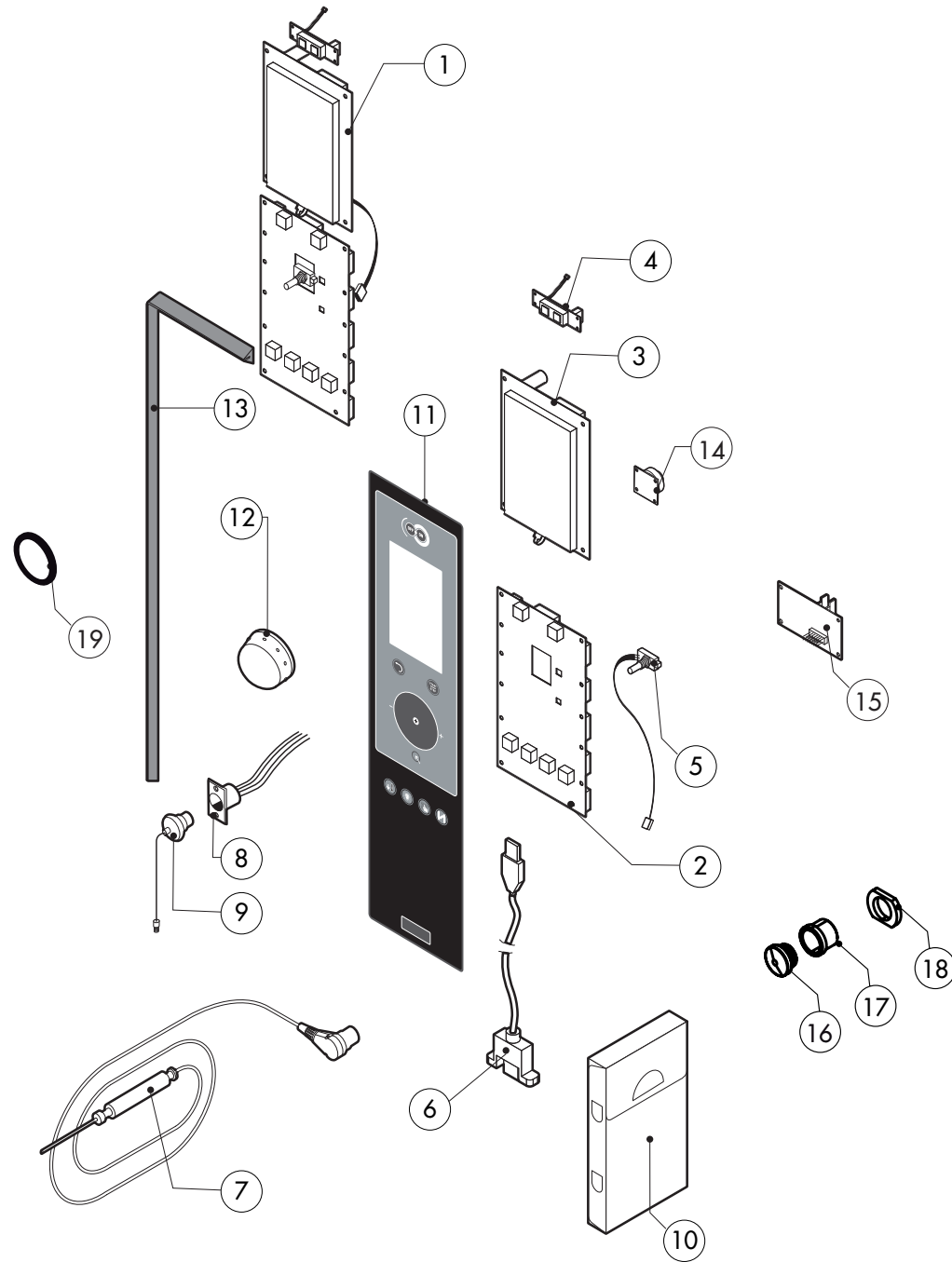

POS.	COD.	Pz.	DESCRIZIONE	DESCRIPTION	DESCRIPTION	BESCHREIBUNG	DESCRIPCIÓN
1	R65302140	1	SCHEDA TASTIERA COMPLETA "X" PASTICCERIA	CONTROL PANEL P.C. BOARD "X" MOD	FICHE PANNEAU COMMANDES "X"	TASTATURPLATINE "X"	PLACA PULSADORES "X"
2	R65301910	1	SCHEDA BASE "X"	MAIN PC BOARD "X" MOD	FICHE PANNEAU PRINCIPAL "X"	HAUPTPLATINE "X"	PLACA BASE "X"
3	R65302340	1	SCHEDA DISPLAY LCD	RELAY PC BOARD "X" MOD	FICHE PANNEAU COMMANDES "X"	TASTATURPLATINE "X"	PLACA PULSADORES "X"
4	R65301930	1	SCHEDA ON/OFF	ON-OFF BOARD "X"	ON-OFF PANNEAU "X"	ON-OFF PLATINE "X"	ON-OFF PLACA "X"
5	R65301940	1	SCHEDA ENCODER	FRONT PC BOARD ENCODER	ENCODER PLATINE	ENCODER F. PLATINE	ENCODER PLACA ELECTRONICA
6	R65301970	1	CAVO USB COLLEGAMENTO SCHEDA	PC BOARD CONNECTION USB	CABLE USB POUR LA PLATINE	REIHENKABLE USB FUR PLATINEVERBINDUNG	CABLE USB CONEXIÓN FICHA
7	R65321100	1	SONDA AL CUORE 4 PUNTI	CORE TEMPERATURE PROBE	SONDE A COEUR	KERNTEMPERATURFUEHLER	SONDA AL CORAZON
8	R65321110	1	CONNETTORE FEMMINA PER SONDA AL CUORE	CORE TEMPERATURE PROBE FEMALE CONNECTOR	CONNECTEUR FEMELLE POUR SONDE A COEUR	STECKDOSE F. KERNTTEMPERATURFUEHLER	CONECTOR HEMBRA PARA SONDA AL CORAZON
9	R65321020	1	TAPPO TEFLON PER CONNETTORE FEMMINA	COVER FOR FEMALE CONNECTOR	BOUCHON POUR CONNECTEUR FEMELLE	ABDECKUNG F. STECKDOSE	TAPON PARA CONECTOR HEMBRA
10	R86020420	1	VALIGETTA SONDA AL CUORE	CORE TEMPERATURE PROBE BOX	PETITE VALISE SONDE A COEUR	TASCHE F. KERNTTEMPERATURFUEHLER	ESTUCHE DE SONDA AL CORAZON
11	-	1	TARGA "X"	PLATE	PLAQUE	BEDIENUNGSFOLIE	PLACA
12	R69030250	1	MANOPOLA	KNOB	POIGNEE COMMANDE	DREHKNOFF	MANETA
13	R70044260	1	GUARNIZIONE CRUSCOTTO	CONTROL PANEL GASKET	ETANCHEITE COMMANDES	DICHTUNG DER BEDIENUNGSBLENDE	JUNTA PANEL DE MANDOS
14	R65301960	1	SUONERIA PER SCHEDA LCD "X" SR.2006	PC BOARD BUZZER	SONNERIE PLATINE	PLATINENSUMMER	ZUMBADOR PLACA ELECTRONICA
15	R65301950	1	SCHEDA ESPANSIONE BRUCIATORI "X" Sr.2006	BOILER CONTROL PC BOARD	FICHE ELECTRON. CONTROLE CHAUDIERE	ESPANSIONSPLATINE	PLACA EXPANSION
16	R65321290	1	ASS.TAPPO PER PRESA USB 2012	COVER	BOUCHON	ABDECKUNG	TAPON
17	R65321250	1	BOCCOLA PER PRESA USB 2012	BUSH	DOUILLE	BUSCH	CASQUILLO
18	R58004380	1	DADO PER PRESA USB 2012	NUT	ECROU	MUTTER	TUERCA
19	R70010250	1	GUARNIZIONE OR 17,17 X 1,78 NBR-70	OR GASKETS 17,17 X 1,78	JOINT OR 17,17 X 1,78	RINGDICHTUNG 17,17 X 1,78	JUNTA OR 17,17 X 1,78

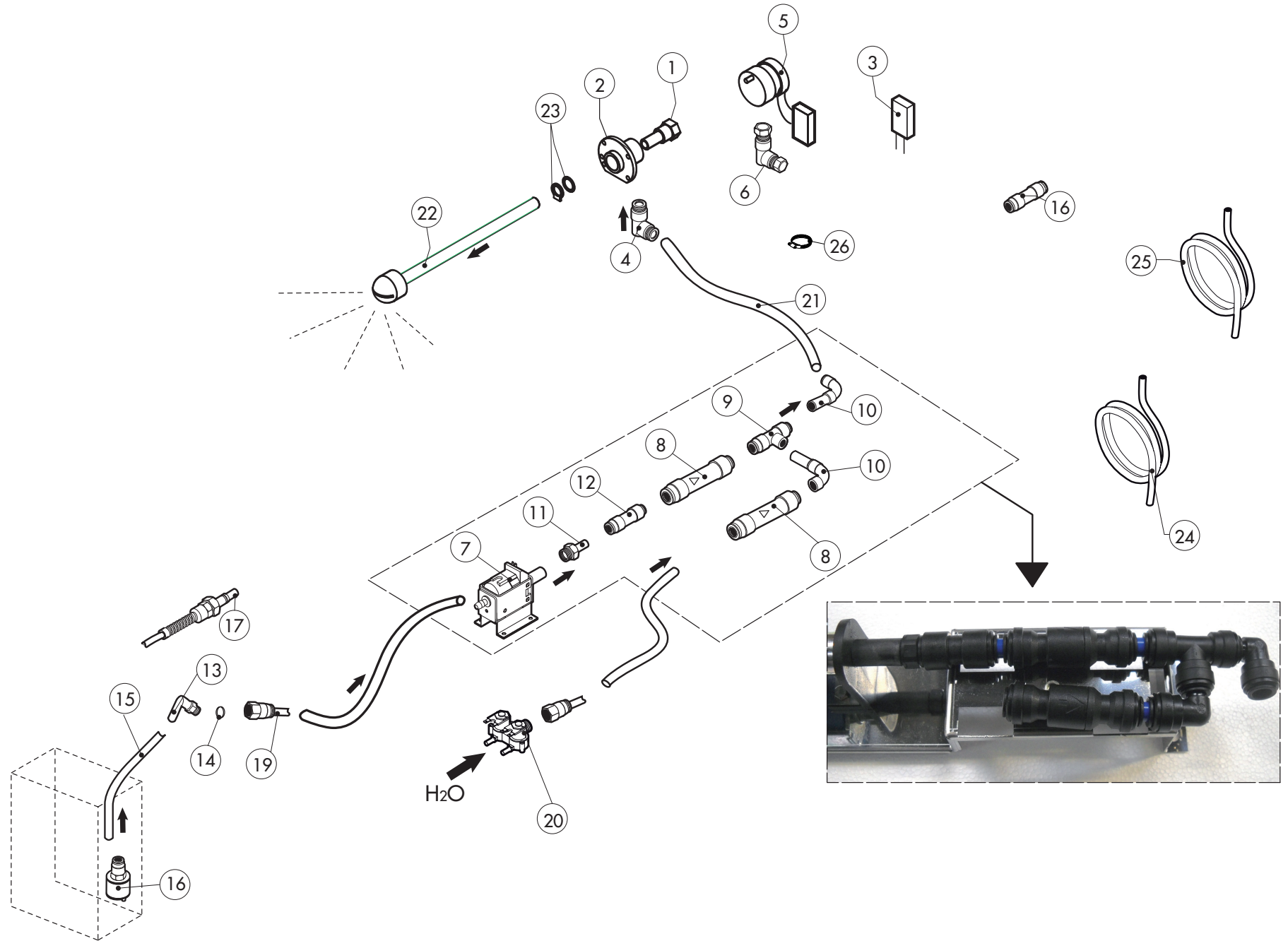

POS.	COD.	Pz.	DESCRIZIONE	DESCRIPTION	DESCRIPTION	BESCHREIBUNG	DESCRIPCIÓN
1	R58007000	1	PERNO ROTANTE LAVAGGIO MOB	ROTATING PIVOT	PIVOT TOURNANT	UMLAUFENDE STÜTZE	GOZNE ROTATORIO
2	R58007020	1	FLANGIA LAVAGGIO MOB	WASHING SYSTEM FLANGE	BRIDE BRAS DE LAVAGE	FLANSCH WASCHARMBEFESTIGUNG	PLATINA LAVADO
3	R65190230	1	CONDENSATORE MOTORE 0,27 µF	CAPACITOR 0,27 µF	CONDENSATEUR 0,27 µF	KONDENSATOR 0,27 µF	CONDENSADOR 0,27 µF
4	R62090663	1	RACCORDO OTTONE NICH. A L C/OGIVA 10X1/4"	ELBOW PIPE FITTING BRASS D.10x1/4"	RACCORDEMENT A COUDE LAITON D 10x1/4"	ELBOW PIPE FITTING BRASS D.10x1/4"	RACOR LATON DE GOMA D.10x1/4"
5	R65090250	1	MOTORID.LAV.SAIA-BURGESS 175022044028-A	WASHING GEARED MOTORS	MOTO-REDUCTEURS DE LAVAGE	GETRIEBEMOTOREN	MOTORREDUCTORES LAVADO
6	R62090633	1	RACCORDO OTTONE CURVO 10/10 C/OGIVA	ELBOW PIPE FITTING BRASS D.10	RACCORDEMENT A COUDE LAITON D 10	WINKELSTUTZEN AUS MESSING D,10	RACOR LATON DE GOMA D.10
7	R65110600	1	POMPA ELETTRON.A PIS.OSC.ET508LAB 2273	POMPE DETERGEANT	DETRGENT PUMP	REINIGERPUMPE	BOMBA DETERGENTE
8	R65110680	2	VALVOLA ANTIRITORNO J.G. 10SCV	ANTI-BACK FLOW	ANTIRETOUR	RUCKFLUSSVERHINDERER	ANTIRETORNO
9	R62090468	1	RACCORDO INTERMEDIO A "T" D.10 PM0210E	T MIDLING PIPE FITTING D.10	RACCORD INTERMEDIAIRE A "T" D.10	MITTELVERBINDUNGSSTUCK D.10 "T"- FORMIG	RACOR INTERMEDIO TIPO "T" D.10
10	R62090528	3	RACC.A GOMITO C/CODOLO 10X10 PM221010E	ELBOW PIPE FITTING (WITH TANG) 10 X 10	COURBE AVEC QUEUE 10x10	WINKELVERBINDUNGSSTUCK 10 X 10 MIT SCHAFT	RACOR DE GOMA CON CODO 10x10
11	R62090608	1	TERMINALE C/CODOLO 8x1/8" PM050811E	8X1/8 END SIDE PIPE FITTING (WITH TANG)	RACCORD AVEC QUEUE 8x1/8"	ENDVERBINDUNGSSTUCK 8 X 1/8" MOT SCHAFT	RACOR TERMINAL CON CODO 8x1/8"
12	R62090618	1	RIDUZIONE INTERMEDIA 10-8 PM201008E	REDUCTION PIPE FITTING	RACCORD DROIT REDUCTION	GERADE ANSCHLUSS-VERKLEINERUNG	RACOR DERECHO REDUCCION
13	R62090648	1	RACCORDO A GOMITO CON PORTAGOMMA	ELBOW PIPE FITTING	COURBE AVEC QUEUE	WINKELVERBINDUNGSSTUCK	RACOR DE GOMA CON CODO
14	R70010050	6	GUARNIZIONE OR 7,60 X 2,62 OR 3030 NB	GASKETS OR 7,60x2,62	OR JOINT	RINGDICHTUNG 7,60X2,62	JUNTA OR 7,60x2,62
15	R70070100	1	TUBO DETERGENTE PE D.8mm x 6	PE D.8 MM X 6 DETERGENT FLEXIBLE PIPE	TUBE DETERGEANT D. 8x6	ROHRLEITUNG F. REINIGER PE D.8MMX6	TUBO DETERGENTE PE D.8mm X 6
16	R65110650	1	VALVOLA DI FONDO PER FILTRO GM.060.35	BOTTOM FILTER	FILTER POUR TUBE DETERGEANT	ANSAUGFILTER F. REINIGUNGSSCHAUCH	VÁLVULA DE FONDO TUBO DEL LIMPIADOR
17	R62090482	1	RACC.RAPIDO MASCHIO X LAVAG. PIPU40-C08M	RAPID MALE PIPE FITTING	RACCORD RAPIDE PARTIE MALE	SCHNELLVERBINDUNG MANNL	RACOR RAPIDO MACHO
18	R62090458	1	RACCORDO INTERMEDIO DRITTO D.10	STRAIGHT MIDLING PIPE FITTING D.10	RACCORD INTERMADIAIRE DROIT D.10	MITTELVERBINDUNGSSTUCK D.10 GERADE	RACOR INTERMEDIO DERECHO D.10
19	R62090538	1	RACC.DIR.F.1/4" TUBO 6X8 A CALZ. PRCF220008	1/4" FEMALE STRAIGHT PIPE FITTING FOR D.6X8 PIPE	RACCORD DROIT PARTIE FEMELLE 1/4" TUBE 6x8	VERBINDUNGSSTUCK 1/4" WEBL. FUR ROHR D.6X8	RACOR DERECHO HEMBRA 1/4" PARA TUBO D.6x8
20	R65110210	1	ELETTRIVALVOLA 2 VIE 220V 50HZ	SOLENOID VALVE 220V 50HZ	ELECTROVANNE 220V 50HZ	MAGNETVENTIL 220V 50HZ	ELECTROVALVULA 220V 50HZ
21	R70070070	1	TUBO PE D.10mm x 7 (1 MT.)	PE D.10 MM X7 WATER FLEXIBLE PIPE	TUBE FLEXIBLE EAU D. 10x7	WASSERFLEXROHRLEITUNG PE D.10MMX7	TUBO FLEXIBLE AGUA PE D.10mm X 7
22	R58007030	1	TESTA LAVAGGIO MOB+ALBERO	WASHING SYSTEM INNER ASSEMBLY	ENSEMBLE INTERIEUR DU LAVAGE	INNEN WASCHARMBEFSTIGUNG	KIT INTERNO LAVADO
23	R70045120	1	KIT GUARNIZIONI X LAVAGGIO MOB	GASKETS KIT	ENSEMBLE JOINTS	DICHTUNGSSATZ	KIT JUNTAS
24	R70070090	1	TUBO SILICONE D.12mm x 7 (1 MT.)	PIPE	TUBE	LEITUNG	TUBO
25	R70070080	1	TUBO GOMMA PER ALIMENTI Di13 De23 L=1MT	PIPE	TUBE	LEITUNG	TUBO
26	R61630011	2	FASCETTE ZINC.12-22/9	METAL CLAMPS 12-22/9	COLLIER DE SERRAGE 12-22/9	VERZINKTE SCHELLEN 12-22/9	ABRAZADERA 12-22/9