

ATTENZIONE: PER TENSIONI SPECIALI, SPECIFICARE SEMPRE IL MODELLO DI FORNO ED IL NUMERO DI MATRICOLA
ATTENTION: FOR SPECIAL VOLTAGES, PLEASE ALWAYS SPECIFY THE OVEN MODEL AND THE SERIAL NUMBER

ATTENTION: POUR TENSIONS SPÉCIALES, MERCI DE SPÉCIFIER TOUJOURS LE MODÈLE DU FOUR ET LE NUMÉRO DE SÉRIE
ACHTUNG: BEI SONDRSPANNUNGEN, BITTE IMMER OFEN-MODELL UND SERIENNUMMER GEBEN.

ed. 0614

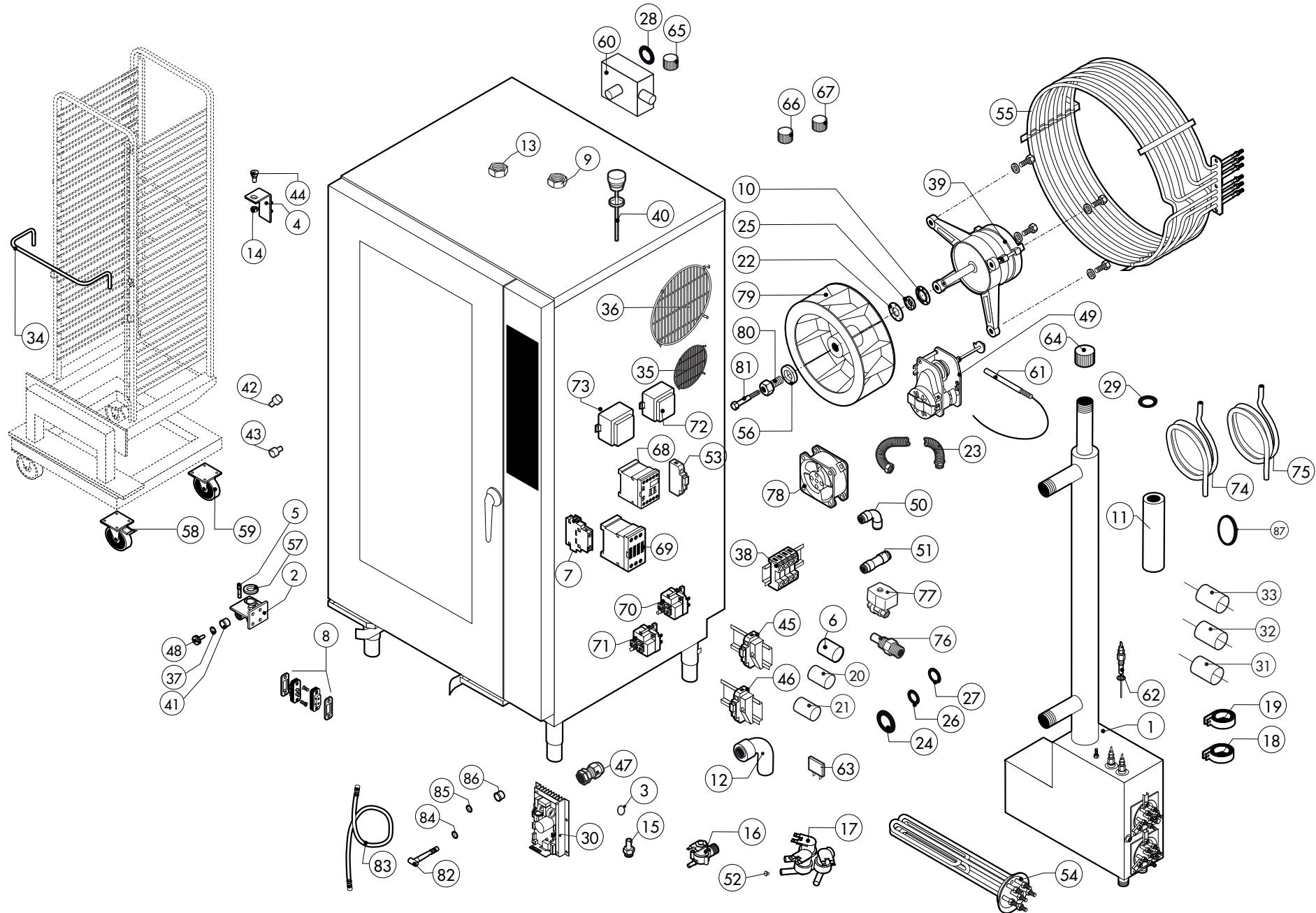

ATTENZIONE: PER ORDINARE I RICAMBI, SPECIFICARE SEMPRE IL MODELLO DI FORNO ED IL NUMERO DI MATRICOLA
ATTENTION: WHEN ORDERING SPARE PARTS, PLEASE ALWAYS SPECIFY THE OVEN MODEL AND THE SERIAL NUMBER

ATTENTION: POUR COMMANDER DES PIÈCES, MERCI DE SPECIFIER TOUJOURS LE MODÈLE DU FOUR ET LE NUMÉRO DE SÉRIE
ACHTUNG: UM ERSATZTEILE ZU BESTELLEN, BITTE IMMER OFEN-MODELL UND SERIENNUMMER GEBEN.

ed. 0614

POS.	COD.	Pz.	DESCRIZIONE	DESCRIPTION	DESCRIPTION	BESCHREIBUNG	DESCRIPCIÓN
1	R11208590	1	ASS. BOILER C/CAL-OUT KME201	STEAM GENERATOR ASSEMBLY	CHAUDIÈRE COMPLETE	DAMPFERZEUGER KOMPLETT	BOILER COMPLETO
2	R11205390	1	ASS. CERNIERA INFERIORE M-V/201-202	LOWER DOOR HINGE	CHARNIÈRE INFÈRIÈURE PORTE	UNTERES SCHARNIER	BISAGRA INFERIOR
3	R62070023	3	BICONO PILOTA TUBO D.6 905.	BICONE D.6	BICONE D. 6	KEGEL D.6	BICONO D.6
4	R11426830	1	CERNIERA SUPER.PORTA SR.2013	UPPER DOOR HINGE	CHARNIÈRE SUPÈRIÈURE PORTE	OBERES SCHARNIER	BISAGRA SUPERIOR
5	R58002540	1	CHIAVETTA X PERNO C/FERMO PORTM-V/120-22	DOOR PIVOT SUNK KEY	CLAVETTE POUR CHEVILLE PORTE	KEIL F. TUERSTIFT	LLAVE PARA PERNO PUERTA
6	R65190220	1	CONDENSATORE 0,47µF 275V	CAPACITOR	CONDENSATEUR	KONDENSATOR	CONDENSADOR
7	R65140430	2	CONT.AUS. 1L+1R 3RH1921-1EA11 SIEMENS	AUX.CONTACT 1L+1R	CONTACT AUXILIAIRE 1L+1R	ZUSÄTZLICHER KONTAKT 1L+1R	CONTACTO AUXILIAR 1L+1R
8	R65260752	1	CONTATTO PER LUCI SR.2014+FORNI A PAVIM.	LAMPS CONTACT BLOCK	CONTACT ECLAIRAGE	LICHTKONTSCHALTER	CONTACTO PARA LUZ
9	R65240040	1	CONTRODADO PER RACCORDO 107 Z/29	CABLE GLAND LOCK NUT	CONTRE-ECROU POUR RONDELLE FIXATION	MUTTER	CONTRODADO PASACABLE
10	R58003850	2	CONTROFLANGIA GUARN.GRANDE	MOTOR GASKET BRASS COUNTER FLANGE	CONTRE- BRIDE JOINT MOTEUR	GEGENFLANSCH F. MOTORDICHTUNG	CONTRABRIDA JUNTA MOTOR
11	R80010110	1	COPPELLA LANA VETRO 76x30mm SCHALEN	ISOLATION	ISOLATION	AISLAMIENTO	DAMMUNG
12	R62280038	1	CURVA C/MORSET.HTS-HTSW X TUBO D.50 D.50X	CURVE WITH TERMINAL	COURBE AVEC BORNIER	KURVE MIT KLEMM	CURVA CON REGLETERA
13	R58004030	2	DADO INOX 1"1/4X8 M/110-210-220 031010	NUT	ECROU	MUTTER	TUERCA
14	R58004050	1	DADO PER PERNO CERNIERA REG. M/106-220	NUT FOR UPPER DOOR HINGE	ECROU CHEVILLE CHARNIERE SUPÈRIÈURE	MUTTER F. OBERES SCHARNIERSTIFT	TUERCA PARA PERNO BISAGRA SUPERIOR
15	R62060223	3	DADO PILOTA TUBO D.6 0903/1.	NUT D.6	ECROU D. 6	MUTTER D.6	DADO D.6
16	R65110200	1	E.V. 1 VIA 220V 50HZ X J.G.CON ATTACC	SOLENOID VALVE	ELECTROVANNE	MAGNETVENTIL	ELECTROVALVULA
17	R65110210	1	E.V. 2 VIE 220V 50HZ X J.G.CON ATTACC	SOLENOID VALVE	ELECTROVANNE	MAGNETVENTIL	ELECTROVALVULA
18	R65280520	1	FERRITE TOROIDALE FT63	FERRITE FT63	FERRITE FT63	FERRIT FT63	FERRITA FT63
19	R65280480	2	FERRITE TOROIDALE FT25	FERRITE FT25	FERRITE FT25	FERRIT FT25	FERRITA FT25
20	R65280240	1	FILTRO FLC470501F	INTERFERENCE SUPPRESSOR	FILTRE ANTIPARASITES	STOERSCHUTZFILTER	FILTRO
21	R65280250	1	FILTRO DI POTENZA RC 3/4KW-PA 575V	SUPPRESSOR	FILTRE	FILTER	FILTRO
22	R58003840	2	FLANGIA GUARN.GRANDE	MOTOR GASKET BRASS FLANGE	BRIDE JOINT MOTEUR	FLANSCH F. MOTORDICHTUNG	BRIDA JUNTA MOTOR
23	R62180182	1	FLEX H2O L=10-20CM M/F1" INOX DADO OT.	FLEXIBLE PIPE	TUBE FLEXIBLE	FLEXROHR	TUBO FLEXIBLE
24	R70010030	1	GUARNIZIONE OR 6,07 X 1,78 SILICONE	GASKET OR 6,07 X 1,78	JOINT OR 6,07 X 1,78	RINGDICHTUNG OR 6,07 X 1,78	JUNTA OR 6,07 X 1,78
25	R70020050	2	GUARNIZIONE MARK IV MLA 2400.02.05	GASKET	JOINT	RINGDICHTUNG	JUNTA
26	R70010210	1	GUARNIZIONE OR NBR 70 18,72x2,62 C.3075	GASKET OR 18,72x2,62	JOINT OR 18,72x2,62	RINGDICHTUNG OR 18,72x2,62	JUNTA OR 18,72x2,62
27	R65070230	1	GUARNIZIONE PER TERM.SIC.CAMERM/106-110	GASKET	JOINT	RINGDICHTUNG	JUNTA
28	R70050150	1	GUARNIZIONE X TAPPO 2" PLAST.G40005	GASKETS	JOINT	RINGDICHTUNG	JUNTA
29	R70050140	1	GUARNIZIONE X TAPPO BOYLER PLAST. G40015	GASKETS	JOINT	RINGDICHTUNG	JUNTA
30	R65140890	2	INVERTER 0.5KW MOT.INF.A001.M005XS8 X RIC	INVERTER	INVERSEUR	INVERTER	INVERSOR
31	R70060080	1	MANICOTTO SILICONE D.13X18X80	SILICON SLEEVE	SILICONE SLEEVE	SILIKONHÜLLE	FUNDA DE SILICONA
32	R70060020	1	MANICOTTO SILICONE D.30X35X9 TAPPO SFIA	SILICON SLEEVE	SILICONE SLEEVE	SILIKONHÜLLE	FUNDA DE SILICONA
33	R70060040	2	MANICOTTO SILICONE D.50X50X3	SILICON SLEEVE	SILICONE SLEEVE	SILIKONHÜLLE	FUNDA DE SILICONA
34	R10457840	1	MANIGLIA CARRELLO KS/021-040	HANDLE FOR TROLLEY	POIGNÉE POUR CHARIOT PORTE POELES	HANDGRIFF-LAUFKATZE	MANIJA CARRO PORTABANDEJAS
35	R75300020	3	MASCHERINA VENTILATORE D.120 PER VENT.	FAN GUARD GRID D.120	GRILLE VENTILATEUR D.120	VENTILATORSCHUTZGITTER D.120	REJILLA VENTILADOR D.120
36	R75300090	2	MASCHERINA VENTILATORE D.350	FAN GUARD GRID D.350	GRILLE VENTILATEUR D.350	VENTILATORSCHUTZGITTER D.350	REJILLA VENTILADOR D.350
37	R61620091	16	MOLLA A TAZZA D.14/6,4X0,8 C70.	BELLEVILLE WASHER Ø 14/6.4	RESSORT A DISQUE Ø 14/6.4	TELLERFEDER Ø 14/6.4	MUELLE A DISCO Ø 14/6.4
38	R65220300	1	MORSETTIERA LX5N MORS.SING.C/TERRA PASS.	TERMINAL BOARD	BORNIER	KLEMMLEISTE	REGLETERA
39	R65040530	2	MOTORE KW 055 F3 4P 3039 200-440V I	MOTOR	MOTEUR	MOTOR	MOTOR
40	R10100140	1	TAPPO SFIATO COMPLETO M/106-.220	COVER	BOUCHON	ABDECKUNG	TAPON
41	R58002550	1	PATTINO FERMO PORTA M-V/120 - 220	DOOR RETAINER GUIDE SHOE	PATIN ARRET PORTE	GLEITSTUECK F. TUEARRETIERUNG	PATILLA CIERRE PUERTA
42	R58003140	2	PERNO AGGANCIO DEFLETTORE	FAN GUARD PANEL PIN	PIVOT DEFLECTEUR	BOLZEN FÜR LUFTLEITBLECH	PERNO CIERRE DEFLECTOR
43	R58000160	2	PERNO FISS.DEFLETTORE K_081-101-A20-201	FAN GUARD PANEL PIN	PIVOT DEFLECTEUR	BOLZEN FÜR LUFTLEITBLECH	PERNO CIERRE DEFLECTOR

TAV. A

KME 201 X

ATTENZIONE: PER ORDINARE I RICAMBI, SPECIFICARE SEMPRE IL MODELLO DI FORNO ED IL NUMERO DI MATRICOLA
ATTENTION: WHEN ORDERING SPARE PARTS, PLEASE ALWAYS SPECIFY THE OVEN MODEL AND THE SERIAL NUMBER

ATTENTION: POUR COMMANDER DES PIÈCES, MERCI DE SPECIFIER TOUJOURS LE MODÈLE DU FOUR ET LE NUMÉRO DE SÉRIE
ACHTUNG: UM ERSATZTEILE ZU BESTELLEN, BITTE IMMER OFEN-MODELL UND SERIENNUMMER GEBEN.

ed. 0614

POS.	COD.	Pz.	DESCRIZIONE	DESCRIPTION	DESCRIPTION	BESCHREIBUNG	DESCRIPCIÓN
44	R58002150	1	PERNO SUP.CERNIERA REG. M/106-220	UPPER HINGE PIN	CHEVILLE CHARNIERE SUPERIEURE	OBERES SCHARNIERSTIFT	PERNO SUPERIOR BISAGRA
45	R65210020	4	PORTAFUSIBILE BARRA DIN 5x20	FUSE CARRIER	PORTE-FUSIBLE	SICHERUNGSHALTER	PORTAFUSIBILE
46	R65210050	1	PORTAFUSIBILE BARRA DIN 6,3x32	FUSE CARRIER	PORTE-FUSIBLE	SICHERUNGSHALTER	PORTAFUSIBILE
47	R65240030	1	PRESSACAVO PG 107 Z/29 (RACCORDO)	FAIRLEAD	PRESSE CABLE	ZUGENTLASTUNG	PRENSACABLES
48	R58002560	1	PRESSORE FERMO PORTA M-V/120- 220	SCREW FOR LOWER DOOR HINGE	VIS POUR CHARNIERE INFERIEURE	DRUCKSCHRAUBE F. UNTERERS TUERSCHARNIER	TORNILLO PARA BISAGRA INFERIOR
49	R65090220	1	PROGRAMMAT. 1 CAMME V220/50HZ 1 CIRCUITO	DAMPER SYSTEM	SORTIE EVAPORATION MOUFLE	DAMPFABLASS-STELLMOTOR	MOTOR RESPIRADERO COMPLETO
50	R62090478	1	RACC. INTERMEDIO A GOMITO D.10 PM0310E	ELBOW PIPE FITTING	COURBE AVEC QUEUE	STUCK MIT SCHAFT	RACOR CON CODO
51	R62090458	3	RACC. INTERMEDIO DIRITTO D.10 PM0410E	PIPE FITTING	COURBE	STUCK	RACOR
52	R65110510	1	REGOL. PORTATA ROSSO ALPHATECH. 1.5LT/H	1.5 LT/H WATER FLOW REDUCER	REGULATUER DE DEBIT 1.5 LT.	DURCHFLOSSMONDERER 1.5 L/STD.	REGULADOR DE CAUDAL 1.5 LT.
53	R65170190	1	RELE' FINDER 40.31.8.230.5000 1 CO.SCAM.	RELAY	RELAIS	RELAIS	RELE
54	R65020421	2	RESISTENZA 15000W 230V BOILER ME/220 TRI	STEAM GENERATOR HEATING ELEMENT 15000W	RESISTANCE CHAUDIERE 15000W	BOILER HEIZKOERPER 15000W	RESISTENCIA BOILER 15000W
55	R65011310	2	RESISTENZA CIRC.15000W 230V CAMME-VE/110-	CHAMBER HEATING ELEMENT 15000W	RESISTANCE MOUFLE 15000W	GARRAUM HEIZKOERPER 15000W	RESISTENCIA CAMARA 15000W
56	R58004010	2	ROND.FISS.VENTOLA D 30/12.5	FAN WASHER Ø 30/12.5	RONDELLE TURBINE Ø 30/12.5	UNTERLEGSCHIEBE Ø 30/12.5	ARANDELA FIJACION TURBINA Ø 30/12.5
57	R58002570	1	RONDELLA 30/15X3 M-V/120-220	WASHER	RONDELLE	UNTERLEGSCHIEBE	ARANDELA
58	R69090360	2	RUOTA GIR.DOPPIA C/FR. D.100(5945UAP100)	WHEEL	ROUE	RAD	RUEDA
59	R69090350	2	RUOTA GIR.DOPPIA D.100 (5940UAP100)	WHEEL	ROUE	RAD	RUEDA
60	R69180100	1	SCATOLA COND.SCARICO H/MV 061-101-201	QUENCHING-DRAIN COLLECTOR	BOITE DE CONDENSATION DECHARGE	KONDENSATION-ABFLUSS SCHACHTEL	CAJON CONDENSACION-DESAGÜE
61	R65320220	3	SONDA "K" 6X80 1,5ML. TESTA RASTREM.20mm	PROBE "K" 6X80 1,5ML.	SONDE "K" 6X80 1,5ML.	FUEHLER "K" 6X80 1,5ML.	SONDA "K" 6X80 1,5ML.
62	R65320010	2	SONDA LIVELLO TL 10/B	LEVEL PROBE	SONDE DE NIVEAU	WASSERSSTANDSFUEHLER	SONDA NIVEL
63	R65147110	5	SURGE SUPPRESSOR (SNABBER) 3RT1926-1CD00	SURGE SUPPRESSOR	PARAFOUDRE	ÜBERSPANNUNGSABLEITER	PROTECTOR DE SOBRETENSIÓN
64	R69150110	1	TAPPO FEMMINA G 1"1/4 PP+25%FV NERO	COVER	BOUCHON	ABDECKUNG	TAPON
65	R69150100	1	TAPPO FEMMINA G 2" PP+25%FV NERO	COVER	BOUCHON	ABDECKUNG	TAPON
66	R62100108	1	TAPPO ROSSO D.10 (PM0810R)	RED COVER	ROUGE BOUCHON	ROTEN ABDECKUNG	TAPON ROJO
67	R58005070	1	TAPPO TANICA VERDE x CALOUT	GREEN COVER	VERT BOUCHON	GRÜNEN ABDECKUNG	TAPON VERDE
68	R65140380	1	TELERUTTORE 3RT1016-1AP02	CONTACTOR	CONTACTEUR	SCHUETZ	CONTACTOR
69	R65140400	8	TELERUTTORE 3RT1025-1AL20 SIEMENS	CONTACTOR	CONTACTEUR	SCHUETZ	CONTACTOR
70	R65070350	1	TERMOSTATO SICUR. 360°C -25K 55.32572.8	THERMOSTAT	THERMOSTAT	THERMOSTAT	TERMOSTATO
71	R65070081	1	TERMOSTATO SICUR.BOILER M/1065532522852	THERMOSTAT	THERMOSTAT	THERMOSTAT	TERMOSTATO
72	R65180420	2	TRASF.RE 20VA 0-220-240/12V MOD.163.16	TRANSFORMER 20VA	TRANSFORMATEUR 20VA	TRANSFORMATOR 20VA	TRANSFORMADOR 20VA
73	R65180430	1	TRASF.RE 40VA 0-220-240/12V MOD.163.82	TRANSFORMER 40VA	TRANSFORMATEUR 40VA	TRANSFORMATOR 40VA	TRANSFORMADOR 40VA
74	R80150000	6	TUBO PE 10MMX7 AZZURRO PM950612E	BLUE PIPE	TUBE	LEITUNG	TUBO
75	R80120060	5m	TUBO SILIC. TRASP.SR60/TR 7/12.	PIPE	TUBE	LEITUNG	TUBO
76	R58006160	2	UGELLO COND.D.0,8 CODOLO CIL.10	NOZZLE	BEC	DÜSE	BOQUILLA
77	R65110570	1	VALVOLA A SFERA MOTORIZZATA 2VIE 230V 1"	STEAM GENERATOR DRAIN MOTORIZED VALVE	DRAINAGE CHAUDIERE	BOILERABLAUFVENTIL	VALVULA DE BOLA MOTORIZADA
78	R65060050	4	VENTILATORE COMPATTO D.120 4715MS 23T	COMPONENTS VENTILATION MOTOR D.120	MOTEUR DE REFRROIDISSMENT D.120	ABKULUNGS MOTOR D.120	MOTOR DE ENFRIAMIENTO D.120
79	R75400440	2	VENTOLA D.350X114/12 50HZ P.D.	FAN	TURBINE	LUEFTERRAD	PALA VENTILADOR
80	R58004000	2	VITE FISS.VENTOLA M/12X1.5 SX	FAN SCREW M12x1.5 SX	VIS DE BLOCAGE TURBINE M12x1.5 SX	VENTILATORSCHRAUBE M12x1.5 SX	TORNILLO FIJACION TURBINA M12x1.5 SX
81	R61020562	2	VITE TE A2 M 6X55 UNI 5737	MOTOR SCREW TE A2 M6x55	VIS DE BLOCAGE MOTEUR TE A2 M6x55	MOTORSCHRAUBE TE A2 M6x55	TORNILLO MOTOR TE A2 M6x55
82	R62200028	1	LANCIA DI LAVAGGIO SENZA TUBO	SHOWER HANDLE	POIGNEE DOUCHETTE	GRIFF F. HANDBRAUSE	MANGO DUCHA
83	R62200058	1	GOMMA 1/2"X1/2"X2.5M LANCIA L.2500mm	FLEXIBLE PIPE SHOWER	TUBE FLEXIBLE DOUCHETTE	SCHEAUCH FUER HANDBRAUSE	TUBO FLEXIBLE DUCHA
84	R70030040	2	GUARNIZIONE D.16X24 3/4 GOMMA.	GASKET D.16X24 3/4	JOINT D.16X24 3/4	DICHTUNG D.16X24 3/4	JUNTA D.16X24 3/4
85	R70030030	1	GUARNIZIONE D. 11X19 1/2"	GASKET D. 11X19 1/2"	JOINT D. 11X19 1/2"	DICHTUNG D. 11X19 1/2"	JUNTA D. 11X19 1/2"
86	R69180300	1	SUPPORTO IN PLAST. X DOCCIONE ESTERNO	HOLDER	SUPPORT	HALTERUNG	SOPORTE
87	R70010130	1	GUARNIZIONE SILICONE ROSSO 80X50 3X3	RED GASKET	JOINT ROUGE	ROTEN DICHTUNG	JUNTA ROJA

TAV. A

KME 201 X

ATTENZIONE: PER TENSIONI SPECIALI, SPECIFICARE SEMPRE IL MODELLO DI FORNO ED IL NUMERO DI MATRICOLA
ATTENTION: FOR SPECIAL VOLTAGES, PLEASE ALWAYS SPECIFY THE OVEN MODEL AND THE SERIAL NUMBER

ATTENTION: POUR TENSIONS SPÉCIALES, MERCI DE SPÉCIFIER TOUJOURS LE MODÈLE DU FOUR ET LE NUMÉRO DE SÉRIE
ACHTUNG: BEI SONDRSPANNUNGEN, BITTE IMMER OFEN-MODELL UND SERIENNUMMER GEBEN.

ed. 0614

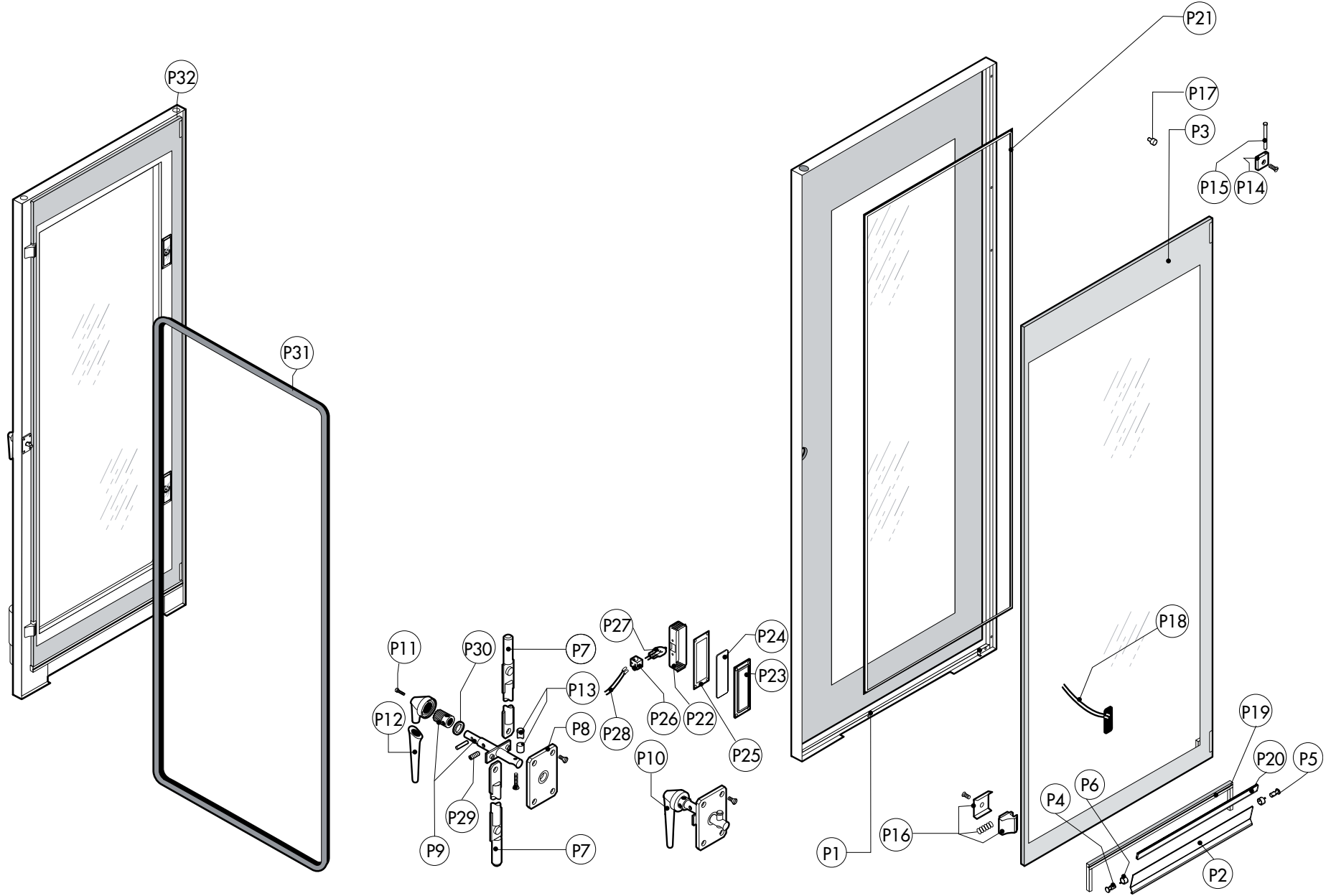

POS.	COD.	Pz.	DESCRIZIONE	DESCRIPTION	DESCRIPTION	BESCHREIBUNG	DESCRIPCIÓN
P1	R11207620	1	PORTA ESTERNA K_201	EXTERNAL DOOR	PORTE D'EXTERNAL	AUSSENTÜR	PUERTA EXTERNA
P2	R11421580	1	BANDELLA DI TAMPONAMENTO K_201	CLOSING PLATE	TÔLE DE FERMETURE	VERSCHLUBLEISTE	PLACA DE CIERRE
P3	R71201870	1	VETRO INTERNO PORTA K_201-202	INNER DOOR GLASS	VERRE INTERIEUR PORTE	INNERES TÜRGLAS	VIDRIO INTERNO PUERTA
P4	R58006861	2	FULCRO X BANDELLA INS. MOLLA	CLOSING PLATE RORAZIONE PIVOT	AXE ROTATION TÔLE DE FERMETURE	DREH	PIVOTE DE CIERRE DE LA PLACA RORAZIONE
P5	R58006910	2	FULCRO FISSAGGIO BANDELLA	PIVOT	AXE	DREHBOLZEN F.VERSCHLUBLEISTE	PIVOTE
P6	R65491250	1	KIT MOLLE BANDELLA TAMPONAMENTO	CLOSING PLATE SPRING ASSEMBLY	KIT RESSORTS TÔLE DE FERMETURE	FEDERSATZ F.VERSCHLUBLEISTE	KIT RESORTE DE PLACA DE CIERRE
P7	R11207670	2	ASS. ASTINA AZ. PUNTONE K_201-202	ROD	CREMAILLÈRE	VERSCHLUSSTANGE	EJE
P8	R03200970	1	ASS. FLANGIA BOCCOLA POST.	DOOR LOCK REAR FLANGE	FLASQUE POSTERIEUR PORTE	FLANSCH	BRIDA SOPORTE POSTERIOR
P9	R11205340	1	ASS. PERNO MANIGLIA M-V/201-202	DOOR HANDLE PIN	AXE MANOEUVRE	SCHLIESSNASE AM TÜRGRIF	PERNO MANETA
P10	R11100311	1	GRUPPO CHIUSURA COMPLETA K_201-202	DOOR CATCH KIT	ENSSEMBLE FERMETURE PORTE	VERSCHLUSSSATZ	MANIJA DE LA PUERTA
P11	R69010740	1	TAPPO MAN. BLU GR.6303 C/ANELLO CROM.	DOOR HANDLE	POIGNEE DE PORTE	GRIFFKORPUS	CUERPO MANETA
P12	R69010810	1	MANIGLIA BLU GR.6303 VERS.2011	HANDLE	POIGNEE	TÜRGRIF	MANGO MANETA
P13	R58004781	1	GANCIO PERNO MANIGLIA C/NOTT. M/120-220	DOOR HANDLE HOOK	DECLIC AXE MANOEUVRE	HAKEN F. TÜRGRIF	GANCHO PERNO MANETA
P14	R58001760	2	CERNIERA FISSA VETRO SR2000	HINGE	CHARNIÈRE	SCHARNIER	BISAGRA
P15	R58001770	2	PERNO CERNIERA VETRO SR2000	INNER GLASS HINGE PIN	PIVOT CHARNIÈRE VERRE INTERIEUR	SCHARNIERBOLZEN F. INNENSCHIEBE	PERNO BISAGRA VIDRIO INTERNO
P16	R58001780	2	FERMO VETRO PORTA P2000	INNER GLASS CATCH KIT	ENSEMBLE ARRET VERRE INTERIEUR	VERSCHLUSSSATZ F. INNENSCHIEBE	KIT FIJACION VIDRIO INTERNO
P17	R70050180	9	DISTANZIALE VETRO 15x8 SIL.55SH M4x12 A2	THICKNESS	EPAISSEUR	DICKE	ESPEJOR
P18	R65265100	1	MICRO PORTA MAGNETICO COMPLETO RIC.	DOOR SWITCH	MICRO PORTE	TUERSCHALTER	MICRO PUERTA
P19	R70044361	1	GUARNIZIONE BATTUTA CAR.C/TAMP.K_201	GASKET	JOINT	DICHTUNG	JUNTA
P20	R80100910	0,4	PROFILO GUARNIZIONE BANDELLA	CLOSING PLATE GASKET	JOINT TÔLE DE FERMETURE	DICHTUNG F.VERSCHLUBLEISTE	JUNTA PARA PLACA DE CIERRE
P21	R80100100	3,58	PROFILO GUARN. 2 CRISTALLI	GASKET	JOINT	DICHTUNG	JUNTA
P22	R11401440	2	CALOTTA LAMPADA SR.2000	LAMP COVER	CALOTTE DE PROJECTEUR	LAMPENKALOTTE	CUBIERTA LAMPARA
P23	R11401450	2	FLANG. STAMP. VETRO LAMP. SR2000	GLASS HOLDER LAMP FLANGE	BRIDE ARRET-VERRE ECLAIRAGE	FLANSCH F.LAMPENVERGLASUNG	TAPA CRISTAL LAMPARA
P24	R71500150	2	VETRO LAMPADA P2000	GLASS LAMP	VERRE PROTECTION LAMPE	LAMPEGLAS	VIDRIO LAMPARA
P25	R70044200	2	GUARNIZIONE VETRO LAMPADA P2000	LAMP GASKET	JOINT VERRE ECLAIRAGE	LAMPENDICHTUNG	JUNTA VIDRIO CUBRELAMPARA
P26	R65270450	2	PORTAL. STUCCHI ART.216	LIGHT SOCKET	DOUILLE	LICHTKONTSCHALTER	PORTALAMPARA PARA LAMPARA HALOGENA
P27	R65270020	2	LAMPADA ALOGENA 20W 12V G4 49040	LIGHT 20W 12V G4	LAMPE 20W 12V G4	LAMPENHALTERUNG	LAMPARA HALOGENA 20W 12V G4
P28	R66110330	1	CABLAGGIO LUCI PORTA M-V/201-202	DOOR LAMPS CABLE SET	CABLES ECLAIRAGE PORTE	VERDRAHTUNG TURBELEUCHTUNG	CABLEADO LUCES PUERTA
P29	R61090052	1	VITE STEI M6x16	GRUB SCREW M6x16	VIS SANS TÊTE M6x16	SENKKOPFSCHRAUBE M6x16	TORNILLO SIN CABEZA M6X16
P30	R61600031	2	ANELLO ELASTICO RADIALE D.3,2 UNI 7434	ELASTIC RING	ANNEAU ÉLASTIQUE	ELASTISCHER RING	ANILLO ELASTICO
P31	R70044910	1	TELAIO GUARN. PORTA K_201	FRONT GASKET	JOINT FACADE	DICHTUNG DER FRONTSEITE	JUNTA FRONTAL
P32	R11103410	1	PORTA COMPLETA K_201	DOOR ASSEMBLY	PORTE COMPLETE	TÜR KOMPLETT	PUERTA COMPLETA

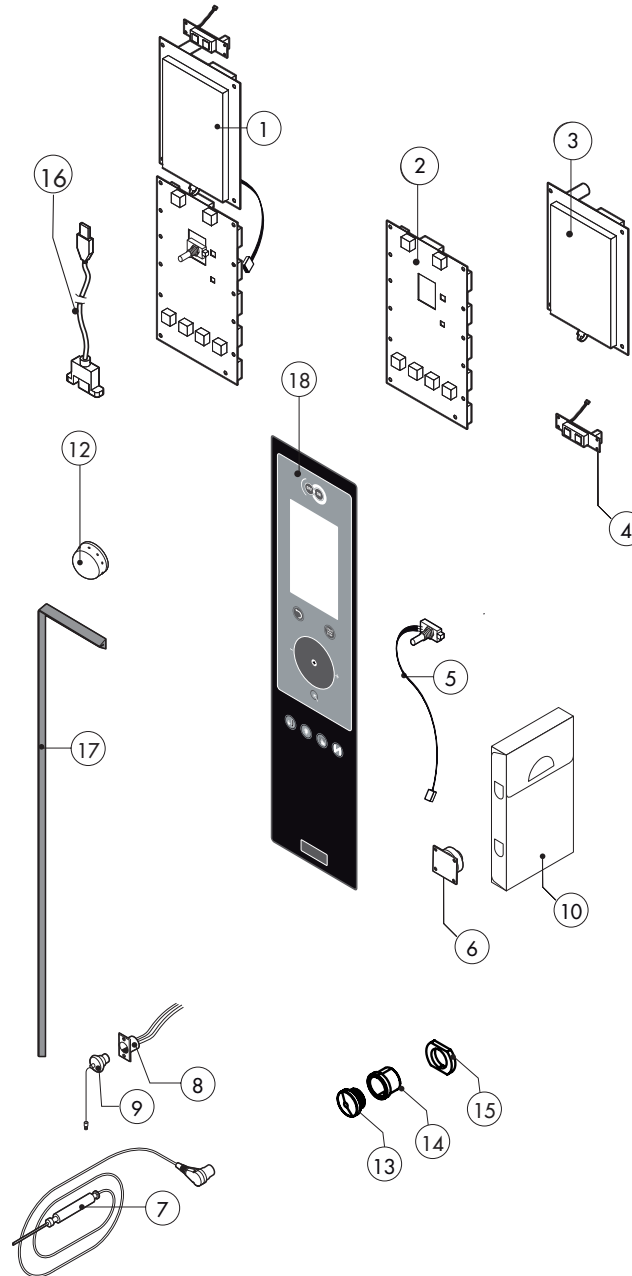

ATTENZIONE: PER TENSIONI SPECIALI, SPECIFICARE SEMPRE IL MODELLO DI FORNO ED IL NUMERO DI MATRICOLA
ATTENTION: FOR SPECIAL VOLTAGES, PLEASE ALWAYS SPECIFY THE OVEN MODEL AND THE SERIAL NUMBER

ATTENTION: POUR TENSIONS SPÉCIALES, MERCI DE SPÉCIFIER TOUJOURS LE MODÈLE DU FOUR ET LE NUMÉRO DE SÉRIE
ACHTUNG: BEI SONDRSPANNUNGEN, BITTE IMMER OFEN-MODELL UND SERIENNUMMER GEBEN.

ed. 0614

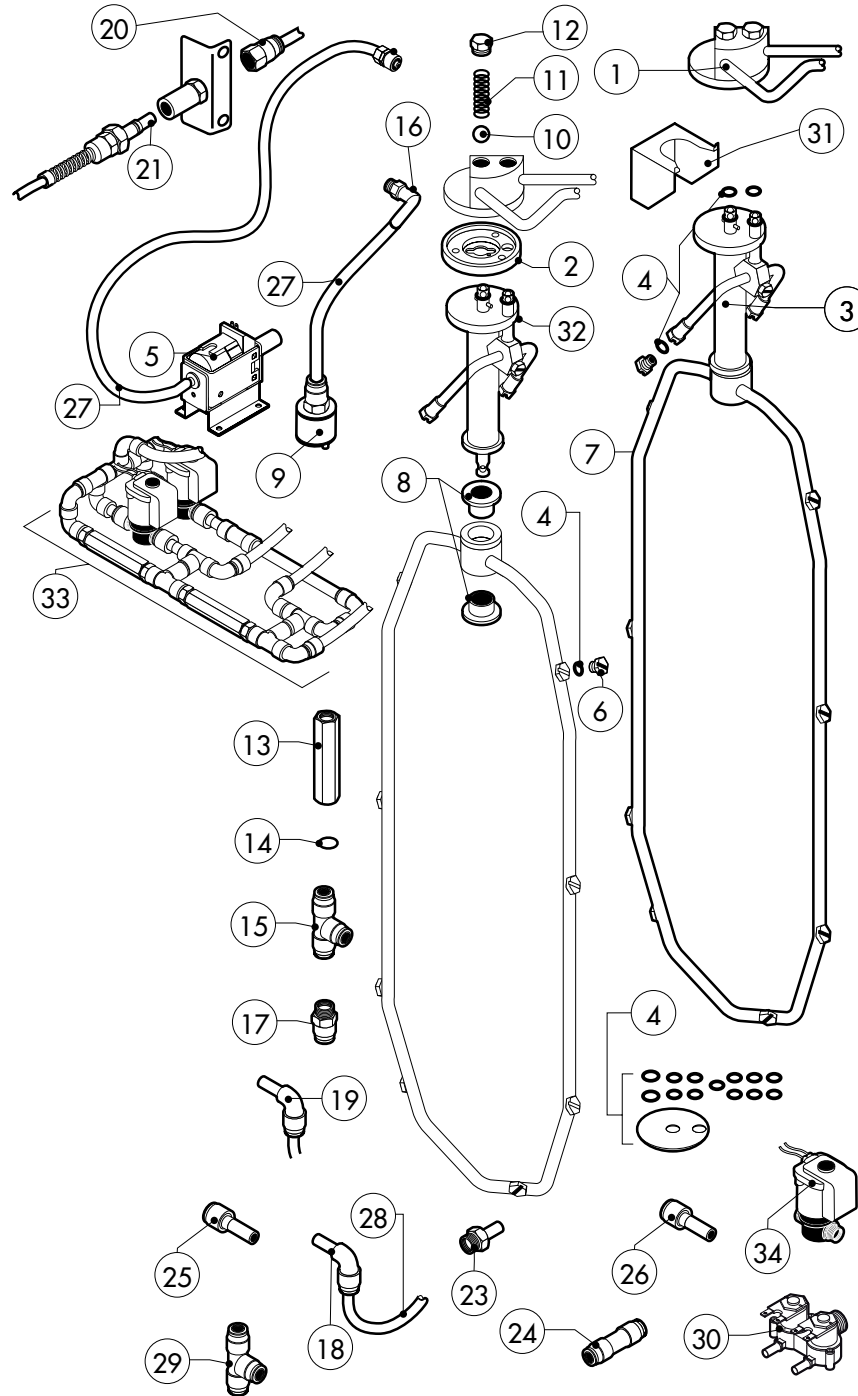
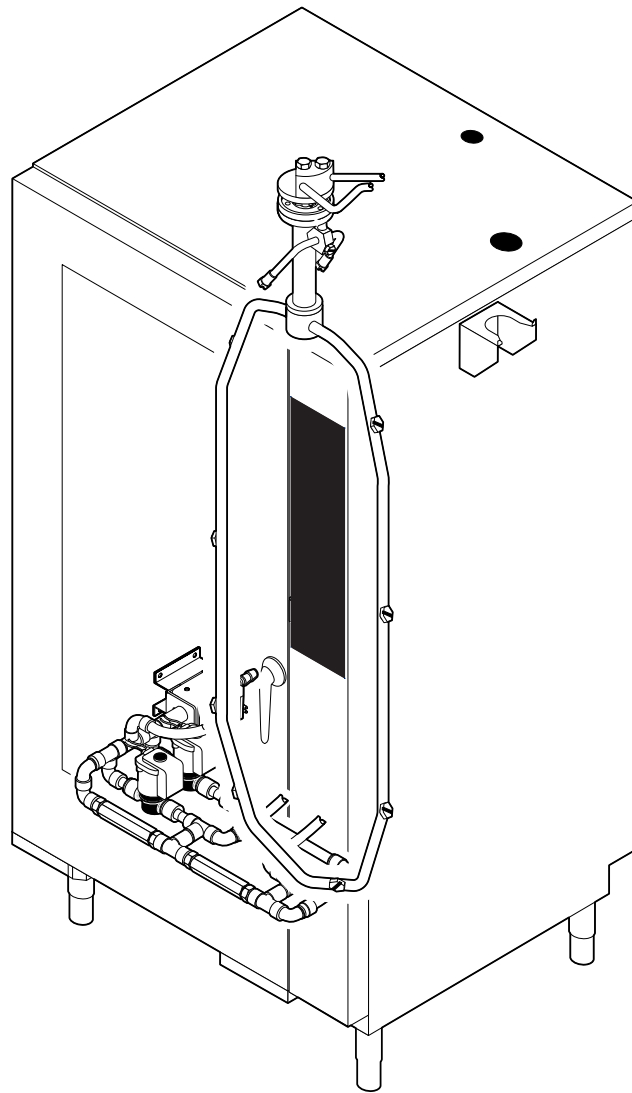

POS.	COD.	Pz.	DESCRIZIONE	DESCRIPTION	DESCRIPTION	BESCHREIBUNG	DESCRIPCIÓN
1	R11203340	1	ASS. BLOCCO ESTERNO LAVAGGIO CAM. K_201	WASHING SYSTEM EXTERNAL ASSEMBLY	ENSEMBLE EXTERIEUR DU LAVAGE	EXTERNE WASCHARMBEFESTIGUNG	BLOQUE EXTERNO LAVADO
2	R58004960	1	FLANGIA INTERNA LAVAGGIO	WASHING SYSTEM INNER FLANGE	BRIDE INTERIEUR BRAS DE LAVAGE	INNEN FLANSCH WASCHARMBEFESTIGUNG	PLATINA INTERNA LAVADO
3	R11100530	1	BRACCIO LAVAGGIO COMPLETO	WASHING DEVICE ASSEMBLY	BRAS DE RINCAGE COMPLET	WASHARM KOMPLETT	BRAZO LAVADO COMPLETO
4	R70045100	1	KIT GUARNIZIONI	GASKETS KIT	ENSEMBLE JOINTS	DICHTUNGSSATZ	KIT JUNTAS
5	R65110600	1	POMPA ELETTR. A PIS. OSC. ET508.	DETRGENT PUMP	POMPE DETERGEANT	REINIGERPUMPE	BOMBA DETERGENTE
6	R62210032	8	UGELLO LAVAGGIO 1,3 L/MIN	1,3 L/MIN RINSING JET	GICLEUR LAVAGE 1,3 LITRE/MINUTE	SPULDUSE REINIGUNG 1,3L/MIN	INYECTOR LAVADO 1,3 L/MIN
7	R62210052	4	UGELLO OVK 110 0,30 L/MIN 1,5BAR	0,30 L/MIN DETERGENT JET	GICLEUR DETERGENT 0,30 LITRE/MINUTE	SPULDUSE REINIGER 0,30 L/MIN	INYECTOR DETERGENTE 0,30 L/MIN
8	R58004980	2	BOCCOLA ROTAZIONE BRACCIO LAVAGGIO	WASHING DEVICE ROTATION BUSH	COQUILLE ROTATION BRAS LAVAGE	DEEHBUCHESE F. WASCHARM	CASQUILLO ROTACION BRAZO LAVADO
9	R65110650	1	VALVOLA DI FONDO PER FILTRO GM.060.35	BOTTOM FILTER	FILTER POUR TUBE DETERGEANT	ANSAUGFILTER F. REINIGUNGSSCHAUCH	VÁLVULA DE FONDO TUBO DEL LIMPIADOR
10	R62220012	2	SFERA D. 14	SPHERA D.14	SPHERE D. 14	VERSCHLUSSKUGEL D.14	ESFERA D. 14
11	R61620041	2	MOLLA	SPRING	RESSORT	FEDER	MUELLE
12	R58005000	2	TAPPO MASCHIO 1/2"	1/2" MALE COVER	BOUCHON 1/2"	MUTTERSTOPFEN 1/2"	TAPON MACHO 1/2"
13	R65110680	2	VALVOLA ANTIRITORNO J.G. 10SCV	ANTI-BACK FLOW	ANTIRETOUR	RÜCKFLUSSVERHINDERER	ANTIRETORNO
14	R70010050	4	GUARNIZIONE OR 7,60x2,62	OR GASKETS 7,60x2,62	JOINT OR 7,60x2,62	RINGDICHTUNG 7,60X2,62	JUNTA OR 7,60x2,62
15	R62090468	5	RACCORDO INTERMEDIO A "T" D.10	T MIDLING PIPE FITTING D.10	RACCORD INTERMEDIAIRE A "T" D.10	MITTELVERBINDUNGSSTÜCK D.10 "T"- FORMIG	RACOR INTERMEDIO TIPO "T" D.10
16	R62090678	2	RACC.A GOMITO C/CODOLO 8X8 PM220808E	ELBOW PIPE FITTING (WITH TANG) 8 X 8	COURBE AVEC QUEUE 8x8	WINKELVERBINDUNGSSTÜCK 8X8 MIT SCHAFT	RACOR DE GOMA CON CODO 8x8
17	R62090688	1	RACC.TERMIN.DIR.FIL.CON.8X1/4 NC2500-P	8x1/4 STRAIGHT THREADED TERMINAL PIPE FITTING	RACCORD FILETE DROIT 8x1/4"	ENDVERBINDUNGSSTÜCK 8x1/4" GESCHNITTEN	RACOR TERMINAL DERECHO ROSCADO 8x1/4"
18	R62090528	6	RACCORDO A GOMITO CON CODOLO 10x10	ELBOW PIPE FITTING (WITH TANG) 10 X 10	COURBE AVEC QUEUE 10x10	WINKELVERBINDUNGSSTÜCK 10 X 10 MIT SCHAFT	RACOR DE GOMA CON CODO 10x10
19	R62090808	2	GOMITO CON CODOLO ø6-ø6 PM220606E	8X1/8 END SIDE PIPE FITTING (WITH TANG)	RACCORD AVEC QUEUE 8x1/8"	ENDVERBINDUNGSSTÜCK 8 X 1/8" MOT SCHAFT	RACOR TERMINAL CON CODO 8x1/8"
20	R62090538	1	RACCORDO DIRITTO FEMMINA 1/4" PER TUBO D.8x6	1/4" FEMALE STRAIGHT PIPE FITTING FOR D.6X8 PIPE	RACCORD DROIT PARTIE FEMELLE 1/4" TUBE 6x8	VERBINDUNGSSTÜCK 1/4" WEBL. FÜR ROHR D.6X8	RACOR DERECHO HEMBRA 1/4" PARA TUBO D.6x8
21	R62090482	1	RACCORDO RAPIDO MASCHIO	RAPID MALE PIPE FITTING	RACCORD RAPIDE PARTIE MALE	SCHNELLEVERBINDUNG MANNL	RACOR RAPIDO MACHO
22	R62090638	1	RACC.RAP.FEMM.X LAV.FIL.FEMM PVPU40-F1/4	RAPID FEMALE PIPE FITTING	RACCORD RAPIDE PARTIE FEMELLE	SCHNELLEVERBINDUNG	RACOR RAPIDO HEMBRA
23	R62090608	2	RACCORDO TERMINALE C/CODOLO 8x1/8"	8X1/8 END SIDE PIPE FITTING (WITH TANG)	RACCORD AVEC QUEUE 8x1/8"	ENDVERBINDUNGSSTÜCK 8 X 1/8" MOT SCHAFT	RACOR TERMINAL CON CODO 8x1/8"
24	R62090458	1	RACCORDO INTERMEDIO DRITTO D.10	PIPE FITTING	COURBE	STÜCK	RACOR
25	R62090618	2	RACCORDO DIRITTO RIDUZIONE 10-8	REDUCTION PIPE FITTING	RACCORD DROIT REDUCTION	GERADE ANSCHLUSS-VERKLEINERUNG	RACOR DERECHO REDUCCION
26	R62090548	4	RACCORDO DIRITTO RIDUZIONE 10-6	REDUCTION PIPE FITTING	RACCORD DROIT REDUCTION	GERADE ANSCHLUSS-VERKLEINERUNG	RACOR DERECHO REDUCCION
27	R80150020	2	TUBO PE D.8mm x 6	PIPE	TUBE	LEITUNG	TUBO
28	R80150030	1	TUBO PE D.10mm x 7 (3 MT.)	PIPE	TUBE	LEITUNG	TUBO
29	R62090488	1	RACCORDO INTERMEDIO A "T" D.6 PM0206E	T MIDLING PIPE FITTING	RACCORD INTERMEDIAIRE A "T"	MITTELVERBINDUNGSSTÜCK "T"- FORMIG	RACOR INTERMEDIO TIPO "T"
30	R65110210	1	ELETR. 2 VIE 220V 50HZ X J.G..	SOLENOID VALVE 220V 50HZ WITH FLOW REDUCER	ELECTROVANNE 220V 50HZ AVEC REG.DE DEBIT	MAGNETVENTIL 220V 50HZ MIT DRUCKMINDERER	ELECTROVALVULA DOBLE 220V 50HZ C/ REDUCT.
31	R11402000	1	SUPPORTO ESTERNO BRACCIO LAVAGGIO	WASHING DEVICE EXTERNAL HOLDER	SUPPORT EXTERIEUR BRAS DE LAVAGE	WANDHALTERUNG FÜR WASHARM	SOPORTE EXTERNO BRAZO LAVADO
32	R14102550	1	TUBO SUPPORTO BRACCIO LAVAGGIO T06-M/072	TUBE DEVICE SUPPORT WASHING	TUBE JE SUPPORTE DISPOSITIF LAVAGE	HALTERUNGSRÖHRWASCHRAUM	TUBO SUPORTE BRAZO LAVADO
33	R62300058	1	GRUPPO ANTIRIT.+SVUOT.COND.K_102-072-201	ANTI-BACK FLOW DEVICE ASSEMBLY	GROUPE JE COMPLÈTE ANTI-RETOUR	KOMPLET RÜCKFLUSSVENTIL SATZ	KIT ANTIRETORNO COMPLETO
34	R65110260	2	ELETTROV.SR.7 NA JOHN GUEST D.6 230V/50HZ	SOLENOID VALVE D.6 230V 50HZ	ELECTROVANNE D.6 230V 50HZ	MAGNETVENTIL D.6 230V 50HZ	ELECTROVALVULA D.6 230V 50HZ
35	R70070080	1	TUBO GOMMA PER ALIMENTI Di13 De23 L=1MT	PIPE	TUBE	LEITUNG	TUBO

