

**ATTENZIONE:** PER TENSIONI SPECIALI, SPECIFICARE SEMPRE IL MODELLO DI FORNO ED IL NUMERO DI MATRICOLA  
**ATTENTION:** FOR SPECIAL VOLTAGES, PLEASE ALWAYS SPECIFY THE OVEN MODEL AND THE SERIAL NUMBER

**ATTENTION:** POUR TENSIONS SPÉCIALES, MERCI DE SPÉCIFIER TOUJOURS LE MODÈLE DU FOUR ET LE NUMÉRO DE SÉRIE  
**ACHTUNG:** BEI SONDRSPANNUNGEN, BITTE IMMER OFEN-MODELL UND SERIENNUMMER GEBEN.

ed. 0614

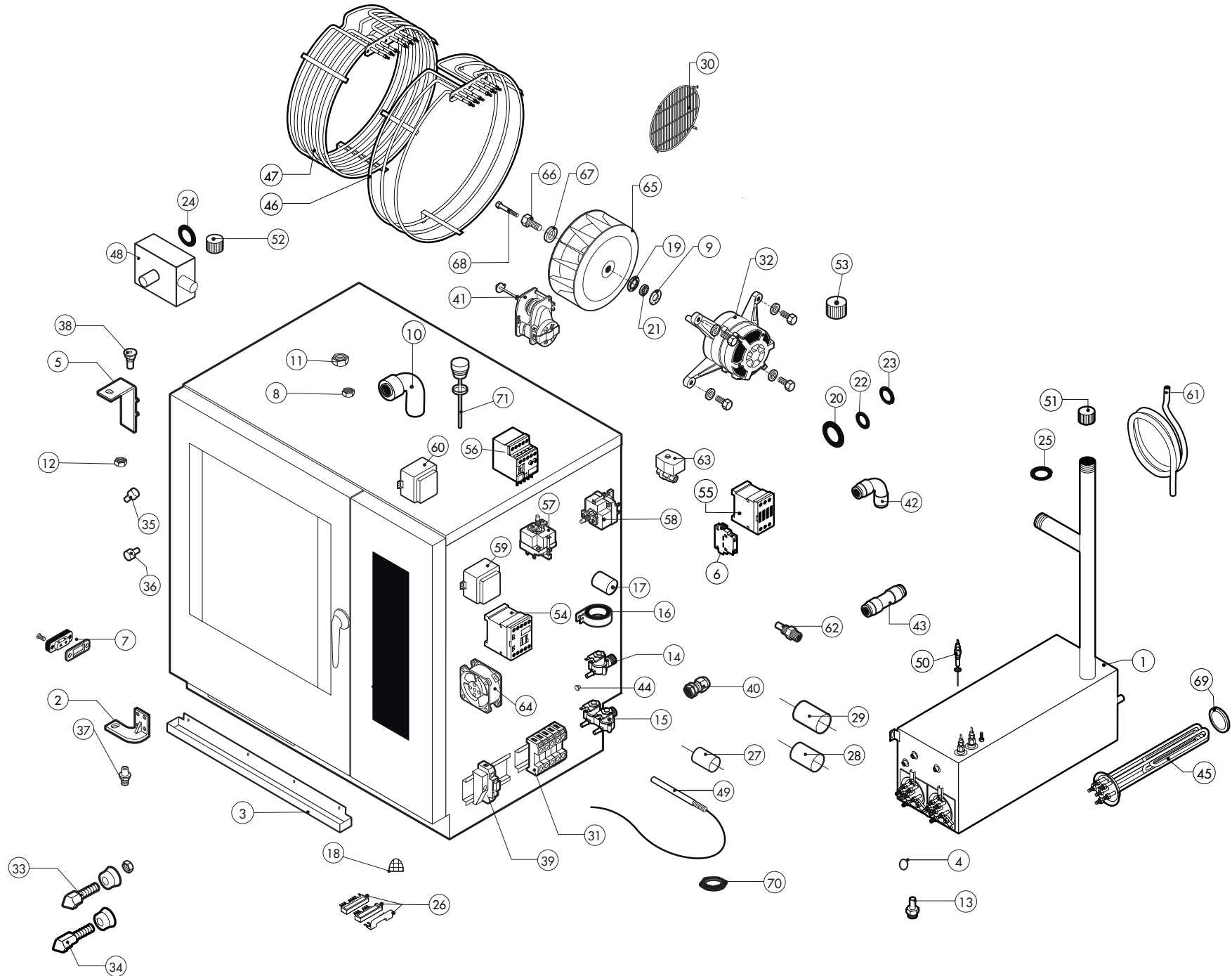

POS.	COD.	Pz.	DESCRIZIONE	DESCRIPTION	DESCRIPTION	BESCHREIBUNG	DESCRIPCIÓN
1	R11206690	1	ASS.BOILER C/CAL-OUT KME102 SCARICO 3/4"	STEAM GENERATOR ASSEMBLY	CHAUDIERE COMPLETE	DAMPFERZEUGER KOMPLETT	BOILER COMPLETO
1	R11206691	1	ASS.BOILER C/CAL-OUT KME102 SCARICO 1" DAL 04/02/2013	STEAM GENERATOR ASSEMBLY FROM 04/02/2013	CHAUDIERE COMPLETE DU 04/02/2013	DAMPFERZEUGER KOMPLETT VOM 04/02/2013	BOILER COMPLETO DEL 04/02/2013
2	R11207240	1	ASS.CERNIERA INF. M-V/061-101-102 2005	LOWER DOOR HINGE	CHARNIERE INFERIEURE PORTE	UNTERES SCHARNIER	BISAGRA INFERIOR
3	R69180170	1	BACINELLA SCARICO H-101	DRIP TRAY	PLATEAU D'ÉGOUTTEMENT	WASSERTROPFTASSE	BANDEJA DEL GOTEO
4	R62070023	2	BICONO PILOTA TUBO D.6 905.	BICONE D.6	BICONE D. 6	KEGEL D.6	BICONO D.6
5	R11426830	1	CERNIERA SUPER.PORTA SR.2013	UPPER DOOR HINGE	CHARNIERE SUPERIEURE PORTE	OBERES SCHARNIER	BISAGRA SUPERIOR
6	R65140430	2	CONT.AUS. 1L+1R 3RH1921-1EA11 SIEMENS	AUX.CONTACT 1L+1R	CONTACT AUXILIAIRE 1L+1R	ZUSÄTZLICHER KONTAKT 1L+1R	CONTACTO AUXILIAR 1L+1R
7	R65260750	1	CONTATTO PER LUCI SR.2000	LAMPS CONTACT BLOCK	CONTACT ECLAIRAGE	LICHTKONTSCHALTER	CONTACTO PARA LUZ
8	R65240040	1	CONTRODADO PER RACCORDO 107 Z/29	CABLE GLAND LOCK NUT	CONTRE-ECROU POUR RONDELLE FIXATION	MUTTER	CONTRODADO PASACABLE
9	R58003850	1	CONTROFLANGIA GUARN.GRANDE	MOTOR GASKET BRASS COUNTER FLANGE	CONTRE- BRIDE JOINT MOTEUR	GEGENFLANSCH F. MOTORDICHTUNG	CONTRABRIDA JUNTA MOTOR
10	R62280038	1	CURVA C/MORSET.HTS-HTSW X TUBO D.50 D.50X	CURVE WITH TERMINAL	COURBE AVEC BORNIER	KURVE MIT KLEMM	CURVA CON REGLETERA
11	R58004030	2	DADO INOX 1"1/4X8 M/110-210-220 031010	NUT	ECROU	MUTTER	TUERCA
12	R58004050	2	DADO PER PERNO CERNIERA REG. M/106-220	NUT FOR UPPER DOOR HINGE	ECROU CHEVILLE CHARNIERE SUPERIEURE	MUTTER F. OBERES SCHARNIERSTIFT	TUERCA PARA PERNO BISAGRA SUPERIOR
13	R62060223	2	DADO PILOTA TUBO D.6 0903/1.	NUT D.6	ECROU D. 6	MUTTER D.6	DADO D.6
14	R65110200	1	E.V. 1 VIA 220V 50HZ X J.G.CON ATTACC	SOLENOID VALVE	ELECTROVANNE	MAGNETVENTIL	ELECTROVALVULA
15	R65110210	1	E.V. 2 VIE 220V 50HZ X J.G.CON ATTACC	SOLENOID VALVE	ELECTROVANNE	MAGNETVENTIL	ELECTROVALVULA
16	R65280490	1	FERRITE TOROIDALE FT36	FERRITE FT36	FERRITE FT36	FERRIT FT36	FERRITA FT36
17	R65280200	3	FILTRO Cx=0,47µF Cy=2X10nF	FILTER	FILTRE	FILTER	FILTRO
18	R69180250	1	FILTRO SCARICO BACINELLA	DRAIN FILTER	FILTRE ENCEINTE	ABFLUSSFILTER	FILTRO DESAGUE
19	R58003840	1	FLANGIA GUARN.GRANDE	MOTOR GASKET BRASS FLANGE	BRIDE JOINT MOTEUR	FLANSCH F. MOTORDICHTUNG	BRIDA JUNTA MOTOR
20	R70010030	1	GUARNIZIONE OR 6,07 X 1,78 SILICONE	GASKET OR 6,07 X 1,78	JOINT OR 6,07 X 1,78	RINGDICHTUNG OR 6,07 X 1,78	JUNTA OR 6,07 X 1,78
21	R70020050	1	GUARNIZIONE MARK IV MLA 2400.02.05	GASKET	JOINT	RINGDICHTUNG	JUNTA
22	R70010210	1	GUARNIZIONE OR NBR 70 18,72x2,62 C.3075	GASKET OR 18,72x2,62	JOINT OR 18,72x2,62	RINGDICHTUNG OR 18,72x2,62	JUNTA OR 18,72x2,62
23	R65070230	1	GUARNIZIONE PER TERM.SIC.CA-MERM/106-110	GASKET	JOINT	RINGDICHTUNG	JUNTA
24	R70050150	1	GUARNIZIONE X TAPPO 2" PLAST.G40005	GASKETS	JOINT	RINGDICHTUNG	JUNTA
25	R70050140	1	GUARNIZIONE X TAPPO BOYLER PLAST. G40015	GASKETS	JOINT	RINGDICHTUNG	JUNTA
26	R65140370	1	KIT INVERSIONE X TELERUTT. 4KW SIEMENS	INVERSION KIT FOR CONTACTOR 4KW	KIT D'INVERSION POUR CONTACTEUR 4KW	KIT WENDEN SCHUETZ 4KW	KIT INVERSION CONTACTOR 4KW
27	R70060080	1	MANICOTTO SILICONE D.13X18X80	SILICON SLEEVE	SILICONE SLEEVE	SILIKONHÜLLE	FUNDA DE SILICONA
28	R70060020	1	MANICOTTO SILICONE D.30X35X9 TAPPO SFA	SILICON SLEEVE	SILICONE SLEEVE	SILIKONHÜLLE	FUNDA DE SILICONA
29	R70060050	3	MANICOTTO SILICONE D.60	SILICON SLEEVE	SILICONE SLEEVE	SILIKONHÜLLE	FUNDA DE SILICONA
30	R75300090	1	MASCHERINA VENTILATORE D.350	FAN GUARD GRID D.350	GRILLE VENTILATEUR D.350	VENTILATORSCHUTZGITTER D.350	REJILLA VENTILADOR D.350
31	R65220300	1	MORSETTIERA LX5N MORS.SING.C/TERRA PASS.	TERMINAL BOARD	BORNIER	KLEMMLEISTE	REGLETERA
32	R65040530	1	MOTORE KW 055 F3 4P 3039 200-440V I	MOTOR	MOTEUR	MOTOR	MOTOR
33	R69010260	1	NASELLO 1 STEP 6303-020022	DOOR LATCH 1 STEP	GACHE DE PORTE POUR OUVERTURE SIMPLE	SCHLISSNASE 1 STUFE	NARIZ 1 CIERRE
34	R69010270	1	NASELLO 2 STEP 6303-020030	DOOR LATCH 2 STEP	GACHE DE PORTE POUR OUVERTURE	SCHLISSNASE 2 STUFE	NARIZ 2 CIERRE
35	R58003140	2	PERNO AGGANCIO DEFLETTORE	FAN GUARD PANEL PIN	PIVOT DEFLECTEUR	BOLZEN FÜR LUFTLEITBLECH	PERNO CIERRE DEFLECTOR
36	R58003110	2	PERNO FISSAGGIO DEFLETTORE	FAN GUARD PANEL PIN	PIVOT DEFLECTEUR	BOLZEN FÜR LUFTLEITBLECH	PERNO CIERRE DEFLECTOR
37	R58002670	1	PERNO INF.CERNIERA REG.C/FERMI SR.2005	LOWER HINGE PIN	CHEVILLE CHARNIERE INFERIEURE	UNTERES SIE SCHARNIERSTIFT	PERNO INFERIOR BISAGRA

POS.	COD.	Pz.	DESCRIZIONE	DESCRIPTION	DESCRIPTION	BESCHREIBUNG	DESCRIPCIÓN
38	R58002150	1	PERNO SUP.CERNIERA REG. M/106-220	UPPER HINGE PIN	CHEVILLE CHARNIERE SUPERIEURE	OBERES SCHARNIERSTIFT	PERNO SUPERIOR BISAGRA
39	R65210020	3	PORTAFUSIBILE BARRA DIN 5x20	FUSE CARRIER	PORTE-FUSIBLE	SICHERUNGSHALTER	PORTAFUSIBILE
40	R65240030	1	PRESSACAVO PG 107 Z/29 (RACCORDO)	FAIRLEAD	PRESSE CABLE	ZUGENTLASTUNG	PRENSACABLES
41	R65090220	1	PROGRAMMAT. 1 CAMME V220/50HZ 1 CIRCUITO	DAMPER SYSTEM	SORTIE EVAPORATION MOUFLE	DAMPFABLAUSS-STELLMOTOR	MOTOR RESPIRADERO COMPLETO
42	R62090478	1	RACC. INTERMEDIO A GOMITO D.10 PM0310E	ELBOW PIPE FITTING	COURBE AVEC QUEUE	STUCK MIT SCHAFT	RACOR CON CODO
43	R62090458	2	RACC. INTERMEDIO DIRITTO D.10 PM0410E	PIPE FITTING	COURBE	STUCK	RACOR
44	R65110510	1	REGOL. PORTATA ROSSO ALPHATECH. 1.5LT/H	1.5 LT/H WATER FLOW REDUCER	REGULATUER DE DEBIT 1.5 LT.	DURCHFLOSSMONDERER 1.5 L/STD.	REGULADOR DE CAUDAL 1.5 LT.
45	R65020421	2	RESISTENZA 15000W 230V BOILER ME/220 TRI	STEAM GENERATOR HEATING ELEMENT 15000W	RESISTANCE CHAUDIERE 15000W	BOILER HEIZKOERPER 15000W	RESISTENCIA BOILER 15000W
46	R65011250	1	RESISTENZA CIRC.15000W 230V CAMME/VE 210-	CHAMBER HEATING ELEMENT 15000W	RESISTANCE MOUFLE 15000W	GARRAUM HEIZKOERPER 15000W	RESISTENCIA CAMARA 15000W
47	R65011310	1	RESISTENZA CIRC.15000W 230V CAMME-VE/110-	CHAMBER HEATING ELEMENT 15000W	RESISTANCE MOUFLE 15000W	GARRAUM HEIZKOERPER 15000W	RESISTENCIA CAMARA 15000W
48	R69180110	1	SCATOLA COND.SCARICO H/MV 102	QUENCHING-DRAIN COLLECTOR	BOITE DE CONDENSATION DECHARGE	KONDENSATION-ABFLUSS SCHACHTEL	CAJON CONDENSACION-DESAGÜE
49	R65320220	3	SONDA "K" 6X80 1,5ML. TESTA RASTREM.20mm	PROBE "K" 6X80 1,5ML.	SONDE "K" 6X80 1,5ML.	FUEHLER "K" 6X80 1,5ML.	SONDA "K" 6X80 1,5ML.
50	R65320010	2	SONDA LIVELLO TL 10/B	LEVEL PROBE	SONDE DE NIVEAU	WASSERSSTANDSFUEHLER	SONDA NIVEL
51	R69150110	1	TAPPO FEMMINA G 1"1/4 PP+25%FV NERO	COVER	BOUCHON	ABDECKUNG	TAPON
52	R69150100	1	TAPPO FEMMINA G 2" PP+25%FV NERO	COVER	BOUCHON	ABDECKUNG	TAPON
53	R58005070	1	TAPPO TANICA VERDE x CALOUT	GREEN COVER	VERT BOUCHON	GRÜN ABDECKUNG	TAPON VERDE
54	R65140380	2	TELERUTTORE 3RT1016-1AP02	CONTACTOR	CONTACTEUR	SCHUETZ	CONTACTOR
55	R65140400	6	TELERUTTORE 3RT1025-1AL20 SIEMENS	CONTACTOR	CONTACTEUR	SCHUETZ	CONTACTOR
56	R65160620	1	TERM.MOT.3RU1116-1BB0 1,4-2,0 SIEMENS	THERMIC PROTECTION 3RU1116-1BB0 1,4-2,0	PROTECTION THERMIQUE 3RU1116-1BB0 1,4-2,0	MOTORSCHUTZSCHALTER 3RU1116-1BB0 1,4-2,0	TERMICO 3RU1116-1BB0 1,4-2,0
57	R65070350	1	TERMOSTATO SICUR. 360°C -25K 55.32572.8	THERMOSTAT	THERMOSTAT	THERMOSTAT	TERMOSTATO
58	R65070081	1	TERMOSTATO SICUR. BOILER M/106532522852	THERMOSTAT	THERMOSTAT	THERMOSTAT	TERMOSTATO
59	R65180420	1	TRASF.RE 20VA 0-220-240/12V MOD.163.16	TRANSFORMER 20VA	TRANSFORMATEUR 20VA	TRANSFORMATOR 20VA	TRANSFORMADOR 20VA
60	R65180430	1	TRASF.RE 40VA 0-220-240/12V MOD.163.82	TRANSFORMER 40VA	TRANSFORMATEUR 40VA	TRANSFORMATOR 40VA	TRANSFORMADOR 40VA
61	R80150000	4	TUBO PE 10MMX7 AZZURRO PM950612E	BLUE PIPE	TUBE	LEITUNG	TUBO
62	R58006160	2	UGELLO COND.D.0,8 CODOLO CIL.10	NOZZLE	BEC	DÜSE	BOQUILLA
63	R65110560	1	VALV. A SFERA MOTOR. 220V 3/4"	STEAM GENERATOR DRAIN MOTORIZED VALVE	DRAINAGE CHAUDIERE	BOILERABLAUFVENTIL	VALVULA DE BOLA MOTORIZADA
63	R65110570	1	VALV. A SFERA MOTOR. 2VIE 230 1" DAL 04/02/2103	STEAM GENERATOR DRAIN MOTORIZED VALVE FROM 04/02/2013	DRAINAGE CHAUDIERE DU 04/02/2013	BOILERABLAUFVENTIL VOM 04/02/2013	VALVULA DE BOLA MOTORIZADA DEL 04/02/2013
64	R65060050	2	VENTILATORE COMPATTO D.120 4715MS 23T	COMPONENTS VENTILATION MOTOR D.120	MOTEUR DE REFROIDISSMENT D.120	ABKÜLUNGS MOTOR D.120	MOTOR DE ENFRIAMIENTO D.120
65	R75400440	1	VENTOLA D.350X114/12 50HZ P.D.	FAN	TURBINE	LUEFTERRAD	PALA VENTILADOR
66	R58004000	1	VITE FISSAGGIO VENTOLA M12x1,5 SX	FAN SCREW M12x1.5 SX	VIS DE BLOCAGE TURBINE M12x1.5 SX	VENTILATORSCHRAUBE M12x1.5 SX	TORNILLO FIJACION TURBINA M12x1.5 SX
67	R58004010	1	RONDELLA FISSAGGIO VENTOLA D30/12,5	FAN WASHER Ø 30/12.5	RONDELLE TURBINE Ø 30/12.5	UNTERLEGSCHLEIBE Ø 30/12.5	ARANDELA FIJACION TURBINA Ø 30/12.5
68	R61020562	1	VITE MOTORE TE A2 M6x55	MOTOR SCREW TE A2 M6x55	VIS DE BLOCAGE MOTEUR TE A2 M6x55	MOTORSCHRAUBE TE A2 M6x55	TORNILLO MOTOR TE A2 M6x55
69	R70045010	2	GUARNIZIONE RESISTENZA BOILER	STEAM GENERATOR HEATING ELEMENT GASKET	JOINT DE RESISTENCE POUR CHAUDIERE	DICHTUNG FUR BOILER HEIZKOERPER	JUNTA RESISTENCIA BOILER
70	R70010120	1	GUARNIZIONE SILICONE ROSSO 90X90X3	RED GASKET	JOINT ROUGE	ROTEN DICHTUNG	JUNTA ROJA
71	R10100140	1	TAPPO SFIATO COMPLETO M/106.-.220	COVER	BOUCHON	ABDECKUNG	TAPON

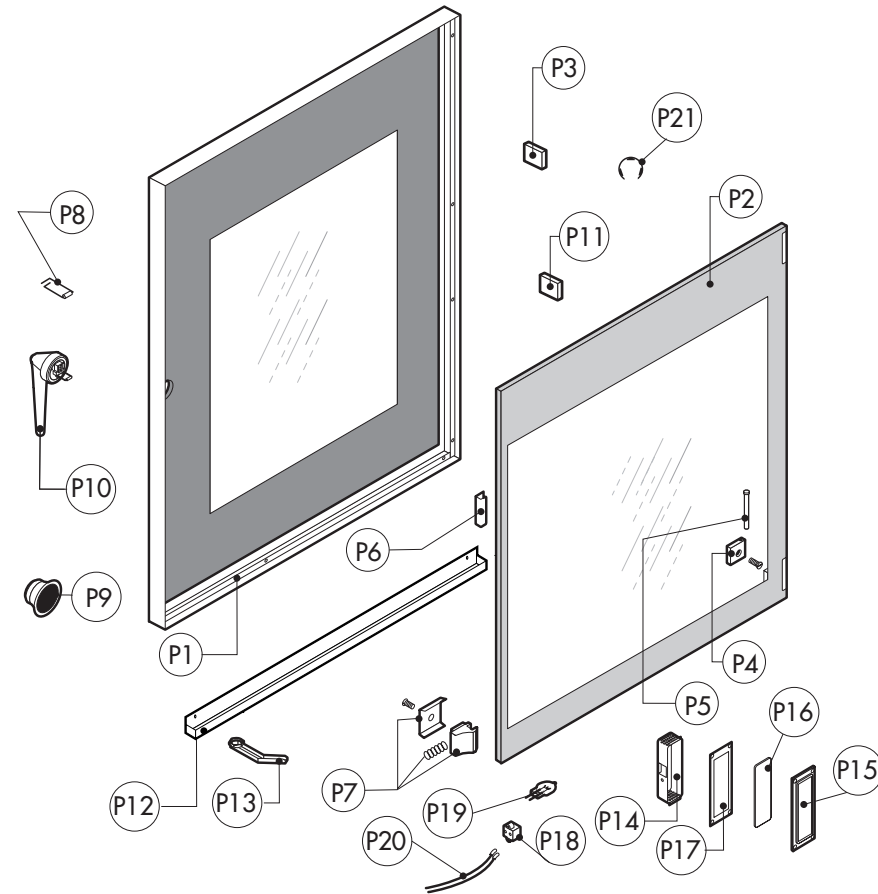
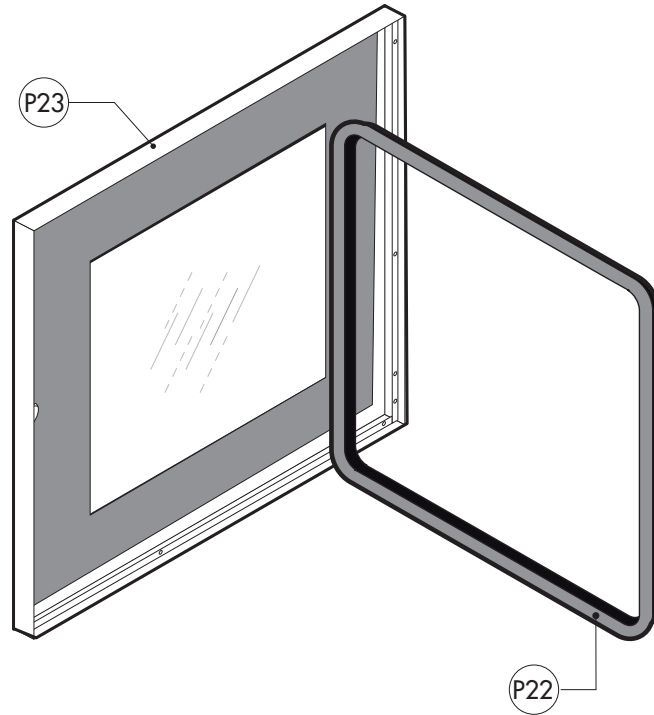



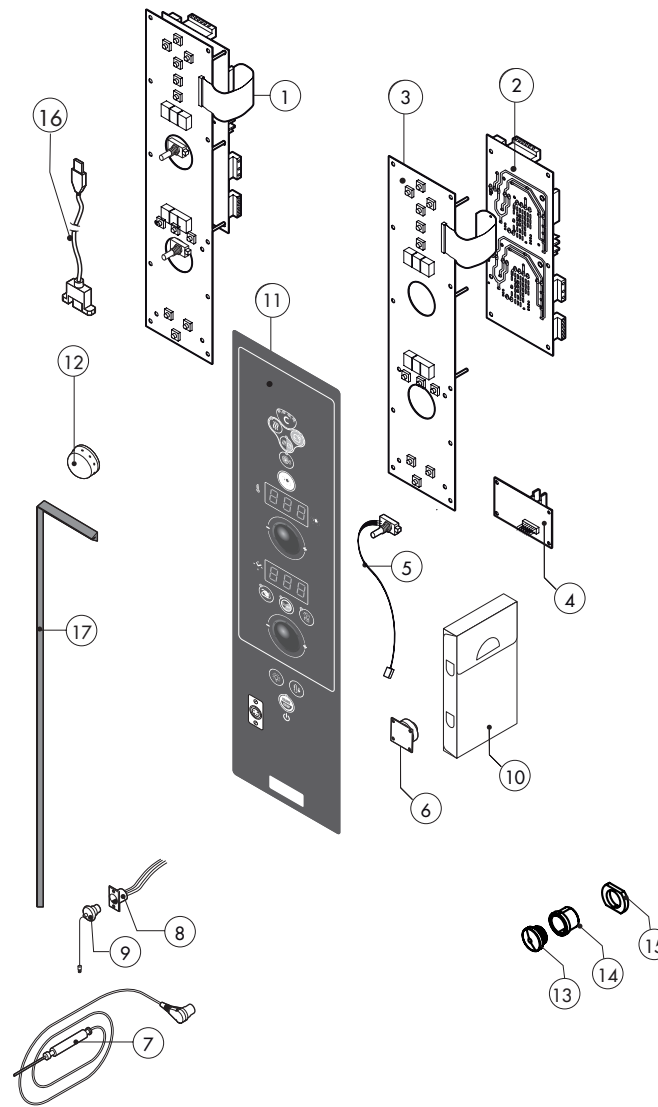

POS.	COD.	Pz.	DESCRIZIONE	DESCRIPTION	DESCRIPTION	BESCHREIBUNG	DESCRIPCIÓN
1	R65302110	1	SCHEDA "S" 2009 COMPLETA+ESPANSIONE	CONTROL PANEL PC BOARD "S" MOD + EXPANSION	PLATINE ÉLECTRONIQUE COMPLÈTE "S" + EXPANSION	STEUERPLATINE KOMPLETT "S" + ESPANSION	PLACA COMPLETA "S" + EXPANSION
2	R65302250	1	SCHEDA BASE "S" 2009	MAIN PC BOARD "S" 2009	FICHE PANNEAU PRINCIPAL "S" 2009	HAUPTPLATINE "S" 2009	PLACA BASE "S" 2009
3	R65302240	1	SCHEDA TASTIERA "S" 2009	RELAY PC BOARD "S" 2009	FICHE PANNEAU COMMANDES "S" 2009	TASTATURPLATINE "S" 2009	PLACA PULSADORES "S" 2009
4	R65302260	1	SCHEDA ESPANSIONE "S" 2009	CONTROL PC BOARD "S" 2009	FICHE ELECTRON. CONTROLE "S" 2009	ESPANSIONSPLATINE "S" 2009	PLACA EXPANSION "S" 2009
5	R65301940	2	ENCODER LCD "X" SR.2006	FRONT PC BOARD ENCODER	ENCODER PLATINE	ENCODER F. PLATINE	ENCODER PLACA ELECTRONICA
6	R65301960	1	SCHEDA BUZZER TOP LCD "X" Sr.2006	PC BOARD BUZZER	SONNERIE PLATINE	PLATINENSUMMER	ZUMBADOR PLACA ELECTRONICA
7	R65321102	1	SONDA AL CUORE K 4 PUNTI 6 PIN.IMP.2012	CORE TEMPERATURE PROBE	SONDE A COEUR	KERNTEMPERATURFUEHLER	SONDA AL CORAZON
8	R65321110	1	CONNETTORE FEMM. S/CUORE 6 PIN	CORE TEMPERATURE PROBE FEMALE CON-NECTOR	CONNECTEUR FEMELLE POUR SOND E A COUER	STECKDOSE F. KERNTEMPERATURFUEHLER	CONECTOR HEMBRA PARA SONDA AL CORAZON
9	R65321020	1	TAPPO X CONNETTORE 4 PIN.	COVER FOR CONNECTOR	BOUCHON POUR CONNECTEUR	ABDECKUNG STECKDOSE	TAPON PARA CONECTOR
10	R86020400	1	VALIGETTA X SONDA AL CUORE TRASPARENTE	CORE TEMPERATURE PROBE BOX	PETITE VALISE SOND E A COEUR	TASCHE F. KERNTEMPERATURFUEHLER	ESTUCHE DE SOND A AL CORAZON
11		1	TASTIERA	PLATE	PLAQUE	BEDIENUNGSFOLIE	TARJETA
12	R69030280	2	MANOPOLA ENCODER D.42 BLU FA 6264	KNOB KIT	POIGNEE COMMANDE	DREHKNOPF	PULSADOR MANETA
13	R65321290	1	ASS. TAPPO PER PRES A USB 2012	COVER	BOUCHON	ABDECKUNG	TAPON
14	R65321250	1	BOCCOLA PER PRES A USB 2012	BUSH	DOUILLE	BUSCH	CASQUILLO
15	R58004380	1	DADO PER PRES A USB 2012	NUT	ECROU	MUTTER	TUERCA
16	R65010350	1	CAVO COLL. SCHEDA/PRES A USB HEART L=750	PC BOARD CONNECETION USB	CABLE USB POUR LA PLATINE	REIHENKABLE USB FÜR PLATINEVERBINDUNG	CABLE USB CONEXIÓN FICHA
17	R80100100	1,4	PROFILO GUARN. NERO 2CRISTALLI DIS.031005	GASKETS	JOINT	RINGDICHTUNG	JUNTA

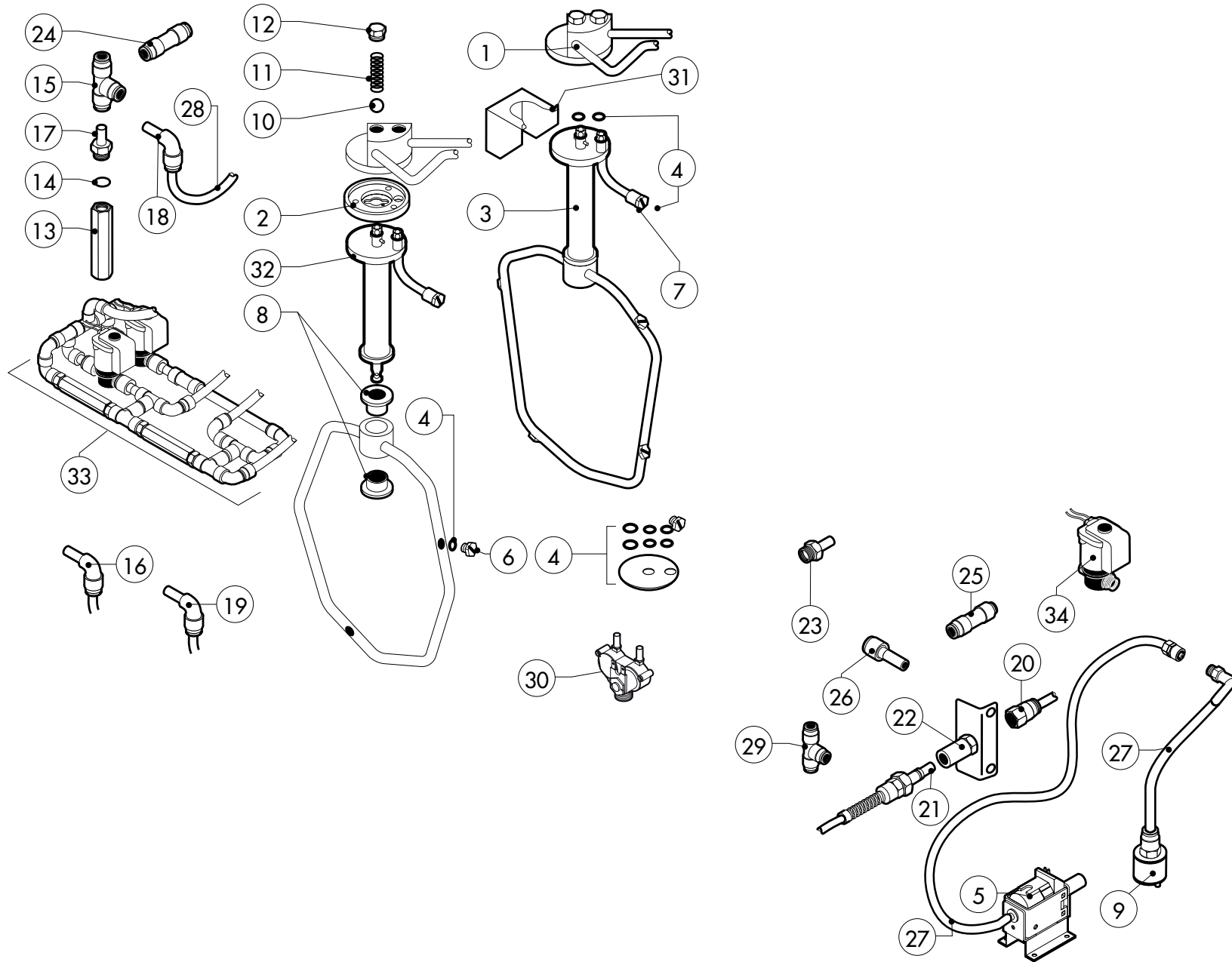



POS.	COD.	Pz.	DESCRIZIONE	DESCRIPTION	DESCRIPTION	BESCHREIBUNG	DESCRIPCIÓN
1	R11200891	1	BLOCCO ESTERNO LAVAGGIO	WASHING SYSTEM EXTERNAL ASSEMBLY	ENSEMBLE EXTERIEUR DU LAVAGE	EXTERNE WASCHARMBEFESTIGUNG	BLOQUE EXTERNO LAVADO
2	R58004960	1	FLANGIA INTERNA LAVAGGIO	WASHING SYSTEM INNER FLANGE	BRIDE INTERIEUR BRAS DE LAVAGE	INNEN FLANSCH WASCHARMBEFESTIGUNG	PLATINA INTERNA LAVADO
3	R11100520	1	BRACCIO LAVAGGIO COMPLETO	WASHING DEVICE ASSEMBLY	BRAS DE RINCAGE COMPLET	WASHARM KOMPLETT	BRAZO LAVADO COMPLETO
4	R70045100	1	KIT GUARNIZIONI	GASKETS KIT	ENSEMBLE JOINTS	DICHTUNGSSATZ	KIT JUNTAS
5	R65110600	1	POMPA ELETTROM.A PIS.OSC.ET508.	DETRGENT PUMP	POMPE DETERGEANT	REINIGERPUMPE	BOMBA DETERGENTE
6	R62210032	4	UGELLO LAVAGGIO 1,3 L/MIN	1,3 L/MIN RINSING JET	GICLEUR LAVAGE 1,3 LITRE/MINUTE	SPULDUSE REINIGUNG 1,3L/MIN	INYEKTOR LAVADO 1,3 L/MIN
7	R62210052	4	UGELLO OVK 110ø 0,30 L/MIN 1,5BAR	0,30 L/MIN DETERGENT JET	GICLEUR DETERGENT 0,30 LITRE/MINUTE	SPULDUSE REINIGER 0,30 L/MIN	INYEKTOR DETERGENTE 0,30 L/MIN
8	R58004980	2	BOCCOLA ROTAZIONE BRACCIO LAVAGGIO	WASHING DEVICE ROTATION BUSH	COQUILLE ROTATION BRAS LAVAGE	DEEHBUCHESE F. WASCHARM	CASQUILLO ROTACION BRAZO LAVADO
9	R65110650	1	VALVOLA DI FONDO PER FILTRO GM.060.35	BOTTOM FILTER	FILTER POUR TUBE DETERGEANT	ANSAUGFILTER F. REINIGUNGSSCHAUCH	VÁLVULA DE FONDO TUBO DEL LIMPIADOR
10	R62220012	2	SFERA D. 14	SPHERA D.14	SPHERE D. 14	VERSCHLUSSKUGEL D.14	ESFERA D.14
11	R61620041	2	MOLLA	SPRING	RESSORT	FEDER	MUELLE
12	R58005000	2	TAPPO MASCHIO 1/2"	1/2" MALE COVER	BOUCHON 1/2"	MUTTERSTOPFEN 1/2"	TAPON MACHO 1/2"
13	R65110680	2	VALVOLA ANTIRITORNO J.G. 10SCV	ANTI-BACK FLOW	ANTIRETOUR	RÜCKFLUSSVERHINDERER	ANTIRETORNO
14	R70010050	4	GUARNIZIONE OR 7,60x2,62	JOINT OR 7,60x2,62	OR GASKETS	RINGDICHTUNG 7,60X2,62	JUNTA OR 7,60x2,62
15	R62090468	4	RACCORDO INTERMEDIO A "T" D.10	T MIDLING PIPE FITTING D.10	RACCORD INTERMEDIAIRE A "T" D.10	MITTELVERBINDUNGSSTÜCK D.10 "T"- FORMIG	RACOR INTERMEDIO TIPO "T" D.10
16	R62090678	2	RACC.A GOMITO C/CODOLO 8X8 PM220808E	ELBOW PIPE FITTING (WITH TANG) 8 X 8	COURBE AVEC QUEUE 8x8	WINKELVERBINDUNGSSTÜCK 8X8 MIT SCHAFT	RACOR DE GOMA CON CODO 8x8
17	R62090688	1	RACC.TERMIN.DIR.FIL.CON.8X1/4 NC2500-P	8x1/4 STRAIGHT THREADED TERMINAL PIPE FITTING	RACCORD FILET DROIT 8x1/4"	ENDVERBINDUNGSSTÜCK 8x1/4" GESCHNITTEN	RACOR TERMINAL DERECHO ROSCADO 8x1/4"
18	R62090528	5	RACCORDO A GOMITO CON CODOLO 10x10	ELBOW PIPE FITTING (WITH TANG) 10 X 10	COURBE AVEC QUEUE 10x10	WINKELVERBINDUNGSSTÜCK 10 X 10 MIT SCHAFT	RACOR DE GOMA CON CODO 10x10
19	R62090808	2	GOMITO CON CODOLO ø6-ø6 PM220606E	8X1/8 END SIDE PIPE FITTING (WITH TANG)	RACCORD AVEC QUEUE 8x1/8"	ENDVERBINDUNGSSTÜCK 8 X 1/8" MOT SCHAFT	RACOR TERMINAL CON CODO 8x1/8"
20	R62090538	1	RACCORDO DIRITTO FEMMINA 1/4" PER TUBO D.8x6	1/4" FEMALE STRAIGHT PIPE FITTING FOR D.6X8 PIPE	RACCORD DROIT PARTIE FEMELLE 1/4" TUBE 6x8	VERBINDUNGSSTÜCK 1/4" WEBL. FÜR ROHR D.6X8	RACOR DERECHO HEMBRA 1/4" PARA TUBO D.6x8
21	R62090482	1	RACCORDO RAPIDO MASCHIO	RAPID MALE PIPE FITTING	RACCORD RAPIDE PARTIE MALE	SCHNELLEVERBINDUNG MANNL	RACOR RAPIDO MACHO
22	R62090638	1	RACC.RAP.FEMM.X LAV.FIL.FEMM PVPU40-F1/4	RAPID FEMALE PIPE FITTING	RACCORD RAPIDE PARTIE FEMELLE	SCHNELLEVERBINDUNG	RACOR RAPIDO HEMBRA
23	R62090608	2	RACCORDO TERMINALE C/CODOLO 8x1/8"	8X1/8 END SIDE PIPE FITTING (WITH TANG)	RACCORD AVEC QUEUE 8x1/8"	ENDVERBINDUNGSSTÜCK 8 X 1/8" MOT SCHAFT	RACOR TERMINAL CON CODO 8x1/8"
24	R62090458	1	RACCORDO INTERMEDIO DRITTO D.10	PIPE FITTING	COURBE	STÜCK	RACOR
25	R62090618	1	RACCORDO DIRITTO RIDUZIONE 10-8	REDUCTION PIPE FITTING	RACCORD DROIT REDUCTION	GERADE ANSCHLUSS-VERKLEINERUNG	RACOR DERECHO REDUCCION
26	R62090548	2	RACCORDO DIRITTO RIDUZIONE 10-6	REDUCTION PIPE FITTING	RACCORD DROIT REDUCTION	GERADE ANSCHLUSS-VERKLEINERUNG	RACOR DERECHO REDUCCION
27	R80150020	2	TUBO PE D.8mm x 6	PIPE	TUBE	LEITUNG	TUBO
28	R80150030	1	TUBO PE D.10mm x 7 (3 MT.)	PIPE	TUBE	LEITUNG	TUBO
29	R62090488	1	RACCORDO INTERMEDIO A "T" D.6 PM0206E	T MIDLING PIPE FITTING	RACCORD INTERMEDIAIRE A "T"	MITTELVERBINDUNGSSTÜCK "T"- FORMIG	RACOR INTERMEDIO TIPO "T"
30	R65110210	1	E.V. 2VIE 220V/50HZ J.G.CON ATTACC	SOLENOID VALVE 220V 50HZ WITH FLOW REDUCER	ELECTROVANNE 220V 50HZ AVEC REG.DE DEBIT	MAGNETVENTIL 220V 50HZ MIT DRUCKMINDERER	ELECTROVALVULA DOBLE 220V 50HZ C/ REDUCT.
31	R11402000	1	SUPPORTO ESTERNO BRACCIO LAVAGGIO	WASHING DEVICE EXTERNAL HOLDER	SUPPORT EXTERIEUR BRAS DE LAVAGE	WANDHALTERUNG FÜR WASHARM	SOPORTE EXTERNO BRAZO LAVADO
32	R14102550	1	TUBO SUPPORTO BRACCIO LAVAGGIO T06-M/072	TUBE DEVICE SUPPORT WASHING	TUBE JE SUPPORTE DISPOSITIF LAVAGE	HALTERUNGSRÖHROWASCHRAUM	TUBO SUPORTE BRAZO LAVADO
33	R62300058	1	GRUPPO ANTIRIT.+SVUOT. COND.K_102-072-201	ANTI-BACK FLOW DEVICE ASSEMBLY	GROUPE JE COMPLÈTE ANTI-RETOUR	KOMPLET RÜCKFLUSSVENTIL SATZ	KIT ANTIRETORNO COMPLETO
34	R65110260	2	ELETTROV.SR.7 NA JOHN GUEST D.6 230V 50HZ	SOLENOID VALVE D.6 230V 50HZ	ELECTROVANNE D.6 230V 50HZ	MAGNETVENTIL D.6 230V 50HZ	ELECTROVALVULA D.6 230V 50HZ
35	R70070080	1	TUBO GOMMA PER ALIMENTI Di13 De23 L=1MT	PIPE	TUBE	LEITUNG	TUBO

