

ATTENZIONE: PER TENSIONI SPECIALI, SPECIFICARE SEMPRE IL MODELLO DI FORNO ED IL NUMERO DI MATRICOLA
ATTENTION: FOR SPECIAL VOLTAGES, PLEASE ALWAYS SPECIFY THE OVEN MODEL AND THE SERIAL NUMBER

ATTENTION: POUR TENSIONS SPÉCIALES, MERCI DE SPÉCIFIER TOUJOURS LE MODÈLE DU FOUR ET LE NUMÉRO DE SÉRIE
ACHTUNG: BEI SONDRSPANNUNGEN, BITTE IMMER OFEN-MODELL UND SERIENNUMMER GEBEN.

ed. 0614

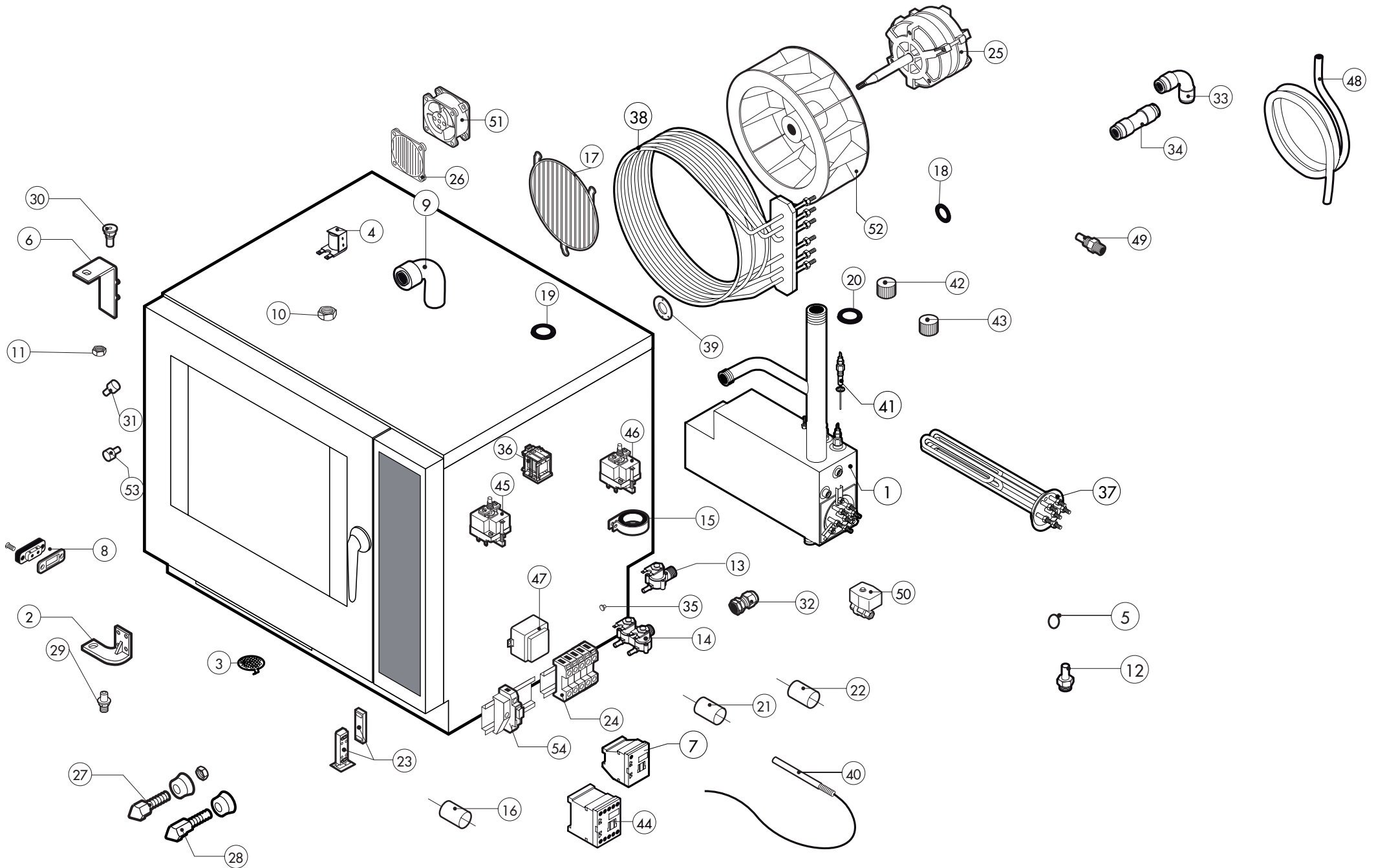

ATTENZIONE: PER ORDINARE I RICAMBI, SPECIFICARE SEMPRE IL MODELLO DI FORNO ED IL NUMERO DI MATRICOLA
ATTENTION: WHEN ORDERING SPARE PARTS, PLEASE ALWAYS SPECIFY THE OVEN MODEL AND THE SERIAL NUMBER

ATTENTION: POUR COMMANDER DES PIÈCES, MERCI DE SPECIFIER TOUJOURS LE MODÈLE DU FOUR ET LE NUMÉRO DE SÉRIE
ACHTUNG: UM ERSATZTEILE ZU BESTELLEN, BITTE IMMER OFEN-MODELL UND SERIENNUMMER GEBEN.

ed. 0614

POS.	COD.	Pz.	DESCRIZIONE	DESCRIPTION	DESCRIPTION	BESCHREIBUNG	DESCRIPCIÓN
1	R18204810	1	ASS.BOILER C/CAL-OUT KME061	STEAM GENERATOR ASSEMBLY	CHAUDIERE COMPLETE	DAMPFERZEUGER KOMPLETT	BOILER COMPLETO
2	R11207240	1	ASS.CERNIERA INF. M-V/061-101-102 2005	LOWER DOOR HINGE	CHARNIERE INFERIEURE PORTE	UNTERES SCHARNIER	BISAGRA INFERIOR
3	R10201700	1	ASS.FILTRO DI SCARICO D.76/44.5 M/106-11	DRAIN FILTER	FILTRE ENCEINTE	ABFLUSSFILTER	FILTRO DESAGUE
4	R65090300	1	ATTUATORE (G01002230V)	MAGNETIC SPOOL	BOBINE MAGNÉTIQUE	MAGNETISCHE SPULE	BOBINA MAGNÉTICA
5	R62070023	3	BICONO PILOTA TUBO D.6 905.	BICONE D.6	BICONE D. 6	KEGEL D.6	BICONO D.6
6	R11426830	1	CERNIERA SUPER.PORTA SR.2013	UPPER DOOR HINGE	CHARNIERE SUPERIEURE PORTE	OBERES SCHARNIER	BISAGRA SUPERIOR
7	R65140730	2	CONT.AUS.1L+1R DILM32-XH11 4-7,5KW MOE.	AUX.CONTACT 1L+1R	CONTACT AUXILIAIRE 1L+1R	ZUSÄTZLICHER KONTAKT 1L+1R	CONTACTO AUXILIAR 1L+1R
8	R65260752	1	CONTATTO PER LUCI SR.2014+FORNI A PAVIM.	LAMPS CONTACT BLOCK	CONTACT ECLAIRAGE	LICHTKONTSCHALTER	CONTACTO PARA LUZ
9	R62280028	1	CURVA C/MORSET.HTS-HTSW X TUBO D.40 D.40X	CURVE WITH TERMINAL	COURBE AVEC BORNIER	KURVE MIT KLEMM	CURVA CON REGLETERA
10	R58004040	2	DADO INOX 3/4"X8 M/106-120 0310103	CURVE WITH TERMINAL	COURBE AVEC BORNIER	KURVE MIT KLEMM	CURVA CON REGLETERA
11	R58004050	2	DADO PER PERNO CERNIERA REG. M/106-220	NUT	ECROU	MUTTER	TUERCA
12	R62060223	3	DADO PILOTA TUBO D.6 0903/1.	NUT FOR UPPER DOOR HINGE	ECROU CHEVILLE CHARNIERE SUPERIEURE	MUTTER F. OBERES SCHARNIERSTIFT	TUERCA PARA PERNO BISAGRA SUPERIOR
13	R65110200	1	E.V. 1 VIA 220V 50HZ X J.G.CON ATTACC	SOLENOID VALVE	ELECTROVANNE	MAGNETVENTIL	ELECTROVALVULA
14	R65110210	1	E.V. 2 VIE 220V 50HZ X J.G.CON ATTACC	SOLENOID VALVE	ELECTROVANNE	MAGNETVENTIL	ELECTROVALVULA
15	R65280450	1	FERRITE TRCN 28-16-20 PASSANTE	FERRITE	FERRITE	FERRIT	FERRITA
16	R65280200	3	FILTRO Cx=0,47µF Cy=2X10nF	INTERFERENCE SUPPRESSOR	FILTRE ANTIPARASITES	STOERSCHUTZFILTER	FILTRO
17	R75300150	1	GRIGLIA VENTILATORE D.170	FAN GUARD GRID D.170	GRILLE VENTILATEUR D.170	VENTILATORSCHUTZGITTER D.170	REJILLA VENTILADOR D.170
18	R70020020	1	GUARNIZIONE DI TENUTA A 04 BAD40 8X22	GASKETS	JOINT	RINGDICHTUNG	JUNTA
19	R70050130	1	GUARNIZIONE TUBO SFIATO D.50	GASKETS	JOINT	RINGDICHTUNG	JUNTA
20	R70050140	1	GUARNIZIONE X TAPPO BOYLER PLAST. G40015	GASKETS	JOINT	RINGDICHTUNG	JUNTA
21	R70060080	1	MANICOTTO SILICONE D.13X18X80	SILICON SLEEVE	SILICONE SLEEVE	SILIKONHÜLLE	FUNDA DE SILICONA
22	R70060090	1	MANICOTTO SILICONE D.24X30X40	SILICON SLEEVE	SILICONE SLEEVE	SILIKONHÜLLE	FUNDA DE SILICONA
23	R65260540	1	MICRO PORTA	DOOR SWITCH	MICRO PORTE	TUERSCHALTER	MICRO PUERTA
24	R65220091	1	MORSETTIERA LX2E (TIPO 2) NEW	TERMINAL BOARD	BORNIER	KLEMMLEISTE	REGLETERA
25	R65041040	1	MOTORE 1F.125W _{in} -75W _{out} 2VEL C/COND. FIR	MOTOR	MOTEUR	MOTOR	MOTOR
26	R75300020	2	MASCHERINA VENTILATORE D.120 PER VENT.	FAN GUARD GRID D.120	GRILLE VENTILATEUR D.120	VENTILATORSCHUTZGITTER D.120	REJILLA VENTILADOR D.120
27	R69010260	1	NASELLO 1 STEP 6303-020022	DOOR LATCH 1 STEP	GACHE DE PORTE POUR OUVERTURE SIMPLE	SCHLISSNASE 1 STUFE	NARIZ 1 CIERRE
28	R69010270	1	NASELLO 2 STEP 6303-020030	DOOR LATCH 2 STEP	GACHE DE PORTE POUR OUVERTURE	SCHLISSNASE 2 STUFE	NARIZ 2 CIERRE
29	R58002670	1	PERNO INF. CERNIERA REG.C/FERMI SR.2005	LOWER HINGE PIN	CHEVILLE CHARNIERE INFERIEURE	UNTERES SIE SCHARNIERSTIFT	PERNO INFERIOR BISAGRA
30	R58002150	1	PERNO SUP.CERNIERA REG. M/106-220	UPPER HINGE PIN	CHEVILLE CHARNIERE SUPERIEURE	OBERES SCHARNIERSTIFT	PERNO SUPERIOR BISAGRA
31	R58001850	8	PERNO SUPP. PARATIE M5 MIXTER	RACK HOLDER	SUPPORT GLUSSIÈRE	BOLZEN AUFLAGESCHIENEN	PERNO SOPORTE MAMPARO
32	R65240010	1	PRESSACAVO PG 107 Z/16	FAIRLEAD	PRESSE CABLE	ZUGENTLASTUNG	PRENSACABLES
33	R62090478	3	RACC. INTERMEDIO A GOMITO D.10 PM0310E	ELBOW PIPE FITTING	COURBE AVEC QUEUE	STUCK MIT SCHAFT	RACOR CON CODO
34	R62090458	2	RACC. INTERMEDIO DIRITTO D.10 PM0410E	PIPE FITTING	COURBE	STUCK	RACOR
35	R65110500	1	REGOL. PORTATA MARRONE ALPHAT. 8L/h	8 LT/H WATER FLOW REDUCER	REGULATUER DE DEBIT 8 LT.	DURCHFLOSSMONDERER 8L/STD.	REGULADOR DE CAUDAL 8 LT.
36	R65170100	2	RELE' FINDER 628282300309PSA	RELAY	RELAIS	RELAIS	RELE
37	R65020280	1	RESISTENZA 6000W 230V BOILER	STEAM GENERATOR HEATING ELEMENT 6000W	RESISTANCE CHAUDIERE 6000W	BOILER HEIZKOERPER 6000W	RESISTENCIA BOILER 6000W
38	R65011960	1	RESISTENZA 8000W 230V D8.5 INC. CAM.K 061	CHAMBER HEATING ELEMENT 8000W	RESISTANCE MOUFLE 8000W	GARRAUM HEIZKOERPER 8000W	RESISTENCIA CAMARA 8000W

TAV. A

KME 061 S

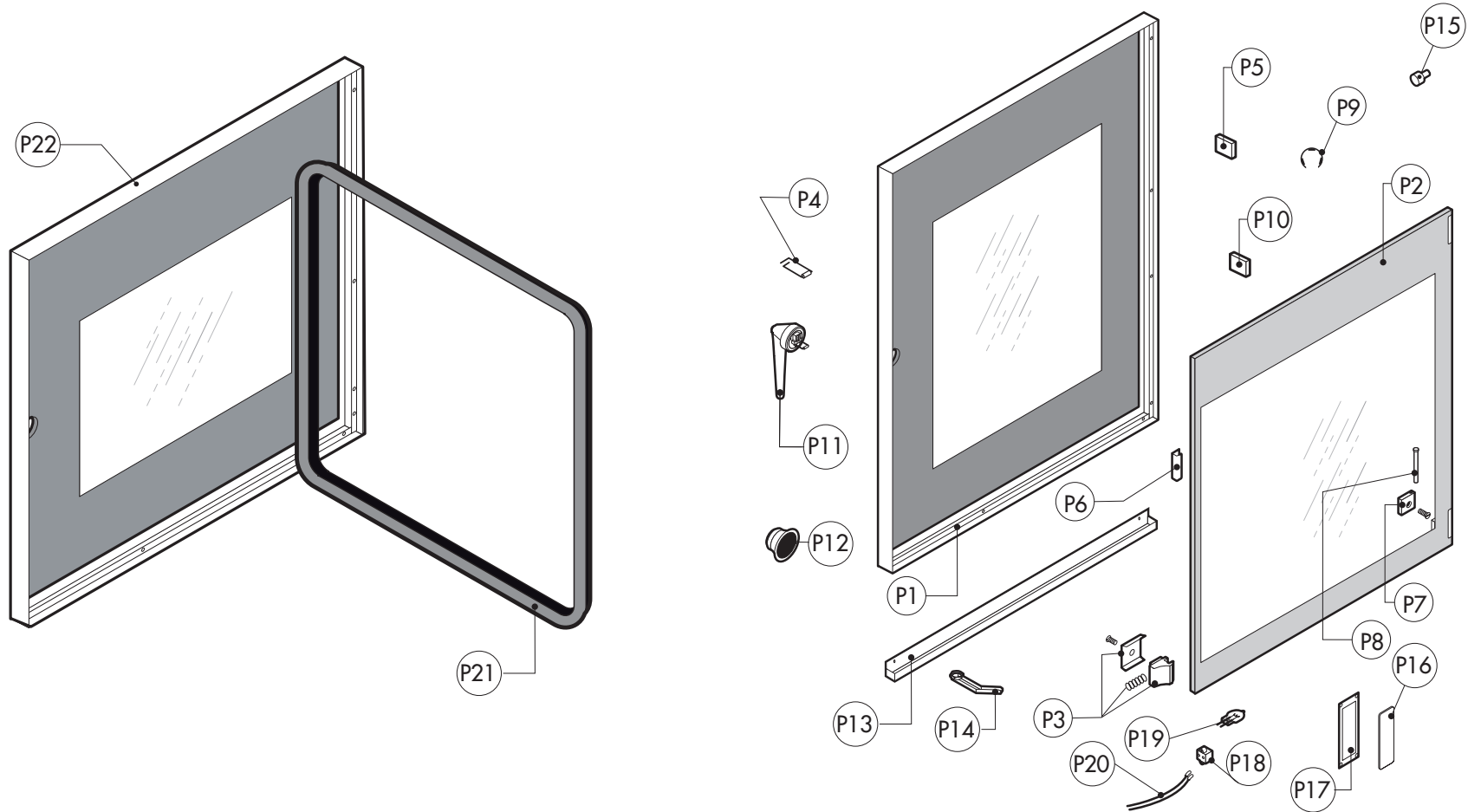

ATTENZIONE: PER ORDINARE I RICAMBI, SPECIFICARE SEMPRE IL MODELLO DI FORNO ED IL NUMERO DI MATRICOLA
ATTENTION: WHEN ORDERING SPARE PARTS, PLEASE ALWAYS SPECIFY THE OVEN MODEL AND THE SERIAL NUMBER

ATTENTION: POUR COMMANDER DES PIÉCES, MERCI DE SPECIFIER TOUJOURS LE MODELE DU FOUR ET LE NUMERO DE SERIE
ACHTUNG: UM ERSATZTEILE ZU BESTELLEN, BITTE IMMER OFEN-MODELL UND SERIENNUMMER GEBEN.

ed. 0614

POS.	COD.	Pz.	DESCRIZIONE	DESCRIPTION	DESCRIPTION	BESCHREIBUNG	DESCRIPCIÓN
P1	R18204760	1	PORTA ESTERNA K_061 LX	EXTERNAL DOOR	PORTE D'EXTERNAL	AUSSENTÜR	PUERTA EXTERNA
P2	R71201570A	1	VETRO POST. PORTA K_061 623X475X6	DOOR GLASS	VITRE PORTE	HARTGLASS	JUNTA
P3	R58001780	2	FERMO VETRO PORTA P2000	INNER GLASS CATCH KIT	ENSEMBLE ARRET VERRE INTERIEUR	VERSCHLUSSSATZ F. INNENSCHIEBE	KIT FIJACION VIDRIO INTERNO
P4	R61620132	1	MOLLA AGGANCIAMENTO NASELLO	DOOR LOCK SPRING	RESSORT DE FERMETURE PORTE	TÜR SCHLUSSFEDER	MUELLE DE ENGANCHE A TRINQUET
P5	R18404520	1	SPESSORE PROTEZIONE VETRO	THICKNESS	EPAISSEUR	DICKE	ESPESOR
P6	R11425830	2	PROT. VETRO PORTA 2011 1LATO40+1LATO15	GLASS PROTECTION	PROTECTION DE VERRE	GLASSCHUTZ	PROTECCION VIDRIO
P7	R58001760	2	CERNIERA FISSA VETRO SR2000	INNER GLASS SOLID HINGE	CHARNIERE VERRE INTERIEUR	SCHARNIER F. INNENSCHIEBE	BISAGRA FIJA VIDRIO INTERNO
P8	R58001770	2	PERNO CERNIERA VETRO SR2000	INNER GLASS HINGE PIN	PIVOT CHARNIERE VERRE INTERIEUR	SCHARNIERBOLZEN F. INNENSCHIEBE	PERNO BISAGRA VIDRIO INTERNO
P9	R61600031	2	ANELLO ELASTICO RADIALE D.3,2 UNI 7434	ELASTIC RING	ANNEAU ÉLASTIQUE	ELASTISCHER RING	ANILLO ELASTICO
P10	R70050180	6	DISTANZIALE VETRO 15x8 SIL.55SH M4x12 A2	THICKNESS	EPAISSEUR	DICKE	ESPESOR
P11	R69010430	1	GRUPPO CHIUS.BASCUL.BLU 6303 VERS.2011	DOOR CATCH KIT	ENSAMBLE FERMETURE PORTE	VERSCHLUSSSATZ	MANIJA DE LA PUERTA
P12	R69010630	1	COP.INT.MECC.CHIUS.GRUPPO 6303.	DOOR HANDLE	POIGNEE DE PORTE	GRIFFKORPUS	CUERPO MANETA
P13	R18204770	1	ASS.BACINELLA PORTA K_061	DRIP TRAY	PLATEAU D'ÉGOUTTEMENT	WASSERTROPFTASSE	BANDEJA DEL GOTEO
P14	R69180010	1	SCARICO BACIN. PORTA DADO ALTO 2009	DOOR DRIP TRAY DRAINAGE	VIDANGE GOUITTIERE SOUS PORTE	ABLAUF TÜRTROPFWANNE	DESAGÜE BANDEJA PUERTA
P15	R58001860	1	PERNO SUPP. PARATIE ALPHATECH	RACK HOLDER	SUPPORT GLISSIERE	BOLZEN AUFLAGESCHIENEN	PERNO SOPORTE MAMPARO
P16	R71500150	1	VETRO LAMPADA P2000	GLASS LAMP	VERRE PROTECTION LAMPE	LAMPEGLAS	VIDRIO LAMPARA
P17	R70044200	1	GUARNIZIONE VETRO LAMPADA P2000	LAMP GASKET	JOINT VERRE ECLAIRAGE	LAMPENDICHTUNG	JUNTA VIDRIO CUBRELAMPARA
P18	R65270450	1	PORTAL. STUCCHI ART.216	LIGHT SOCKET	DOUILLE	LICHTKONTSCHALTER	PORTALAMPARA PARA LAMPARA HALOGENA
P19	R65270020	1	LAMPADA ALOGENA 20W 12V G4 49040	LIGHT 20W 12V G4	LAMPE 20W 12V G4	LAMPENHALTERUNG	LAMPARA HALOGENA 20W 12V G4
P20	R66110310	1	CABLAGGIO LUCI PORTA M-V/061	DOOR LAMPS CABLE SET	CABLES ECLAIRAGE PORTE	VERDRAHTUNG TURBELEUCHTUNG	CABLEADO LUCES PUERTA
P21	R70044340	1	TELAIO GUARN. PORTA A V-C 05	FRONT GASKET	JOINT FACADE	DICHTUNG DER FRONTSEITE	JUNTA FRONTAL
P22	R11103290	1	PORTA COMPLETA K_061 LX	DOOR ASSEMBLY	PORTE COMPLETE	TUER KOMPLETT	PUERTA COMPLETA

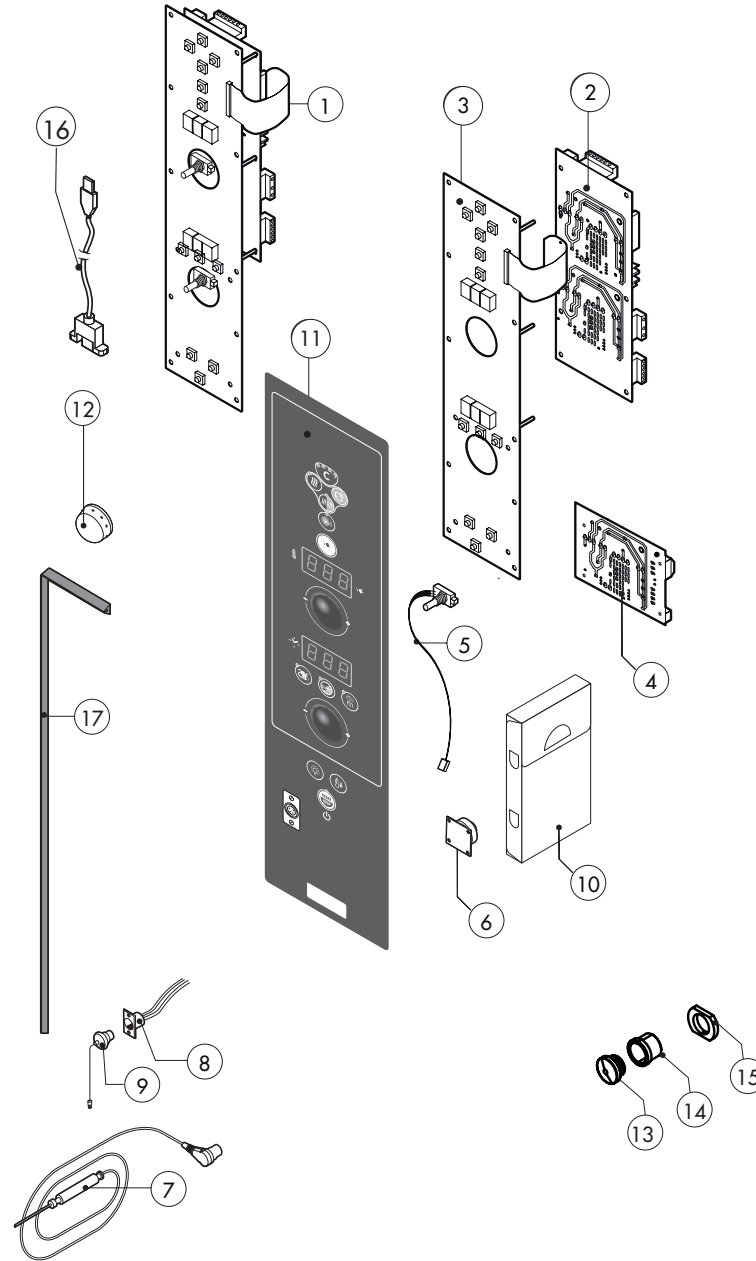

ATTENZIONE: PER ORDINARE I RICAMBI, SPECIFICARE SEMPRE IL MODELLO DI FORNO ED IL NUMERO DI MATRICOLA
ATTENTION: WHEN ORDERING SPARE PARTS, PLEASE ALWAYS SPECIFY THE OVEN MODEL AND THE SERIAL NUMBER

ATTENTION: POUR COMMANDER DES PIÉCES, MERCI DE SPECIFIER TOUJOURS LE MODELE DU FOUR ET LE NUMERO DE SERIE
ACHTUNG: UM ERSATZTEILE ZU BESTELLEN, BITTE IMMER OFEN-MODELL UND SERIENNUMMER GEBEN.

ed. 0614

POS.	COD.	Pz.	DESCRIZIONE	DESCRIPTION	DESCRIPTION	BESCHREIBUNG	DESCRIPCIÓN
1	R65302220	1	SCHEDA "S" COMPACT 2009 COMPL. SANDWICH	CONTROL PANEL PC BOARD "S" COMPACT 2009	PLATINE ÉLECTRONIQUE COMPLÈTE "S" COMPACT 2009	STEUERPLATINE KOMPLETT "S" COMPACT 2009	PLACA COMPLETA "S" COMPACT 2009
2	R65302280	1	SCHEDA BASE "S" COMPACT 2009	MAIN PC BOARD "S" COMPACT 2009	FICHE PANNEAU PRINCIPAL "S" COMPACT 2009	HAUPTPLATINE "S" COMPACT 2009	PLACA BASE "S" COMPACT 2009
3	R65302270	1	SCHEDA TASTIERA "S" COMPACT 2009 042-REV	RELAY PC BOARD "S" COMPACT 2009	FICHE PANNEAU COMMANDES "S" COMPACT 2009	TASTAURPLATINE "S" COMPACT 2009	PLACA PULSADORES "S" COMPACT 2009
4	R65302400	1	SCHEDA ESPANSIONE "S"- "X" COMPACT	BOILER CONTROL PC BOARD	FICHE ELECTRON. CONTROLE CHAUDIERE	ESPANSIONSPLATINE	PLACA EXPANSION
5	R65301940	2	ENCODER LCD "X" SR.2006	FRONT PC BOARD ENCODER	ENCODER PLATINE	ENCODER F. PLATINE	ENCODER PLACA ELECTRONICA
6	R65301960	1	SUONERIA PER SCHEDA LCD "X" Sr.2006	PC BOARD BUZZER	SONNERIE PLATINE	PLATINENSUMMER	ZUMBADOR PLACA ELECTRONICA
7	R65321102	1	SONDA AL CUORE K 4 PUNTI 6 PIN.IMP.2012	CORE TEMPERATURE PROBE	SONDE A COEUR	KERNTEMPERATURFUEHLER	SONDA AL CORAZON
8	R65321110	1	CONNETTORE FEMM. S/CUORE 6 PIN	CORE TEMPERATURE PROBE FEMALE CONNECTOR	CONNECTEUR FEMELLE POUR SONDE A COUER	STECKDOSE F. KERNTEMPERATURFUEHLER	CONECTOR HEMBRA PARA SONDA AL CORAZON
9	R65321020	1	TAPPO X CONNETTORE 4 PIN.	COVER FOR CONNECTOR	BOUCHON POUR CONNECTEUR	ABDECKUNG STECKDOSE	TAPON PARA CONECTOR
10	R86020400	1	VALIGETTA X SONDA AL CUORE TRASPARENTE	CORE TEMPERATURE PROBE BOX	PETITE VALISE SONDE A COEUR	TASCHE F. KERNTEMPERATURFUEHLER	ESTUCHE DE SONDA AL CORAZON
11		1	TASTIERA	PLATE	PLAQUE	BEDIENUNGSFOLIE	TARJETA
12	R69030280	2	MANOPOLA ENCODER D.42 BLU FA 6264	KNOB KIT	POIGNEE COMMANDE	DREHKNOPF	PULSADOR MANETA
13	R65321290	1	ASS.TAPPO PER PRESA USB 2012	COVER	BOUCHON	ABDECKUNG	TAPON
14	R65321250	1	BOCCOLA PER PRESA USB 2012	BUSH	DOUILLE	BUSCH	CASQUILLO
15	R58004380	1	DADO PER PRESA USB 2012	NUT	ECROU	MUTTER	TUERCA
16	R65010350	1	CAVO COLL. SCHEDA/PRESA USB HEART L=750	PC BOARD CONNECTION USB	CABLE USB POUR LA PLATINE	REIHENKABLE USB FÜR PLATINEVERBINDUNG	CABLE USB CONEXIÓN FICHA
17	R80100100	1	PROFILO GUARN. NERO 2 CRISTALLI DIS.031005	GASKET	JOINT	DICHTUNG	JUNTA

ATTENZIONE: PER TENSIONI SPECIALI, SPECIFICARE SEMPRE IL MODELLO DI FORNO ED IL NUMERO DI MATRICOLA
ATTENTION: FOR SPECIAL VOLTAGES, PLEASE ALWAYS SPECIFY THE OVEN MODEL AND THE SERIAL NUMBER

ATTENTION: POUR TENSIONS SPÉCIALES, MERCI DE SPÉCIFIER TOUJOURS LE MODÈLE DU FOUR ET LE NUMÉRO DE SÉRIE
ACHTUNG: BEI SONDRERSPANNUNGEN, BITTE IMMER OFEN-MODELL UND SERIENNUMMER GEBEN.

ed. 0614

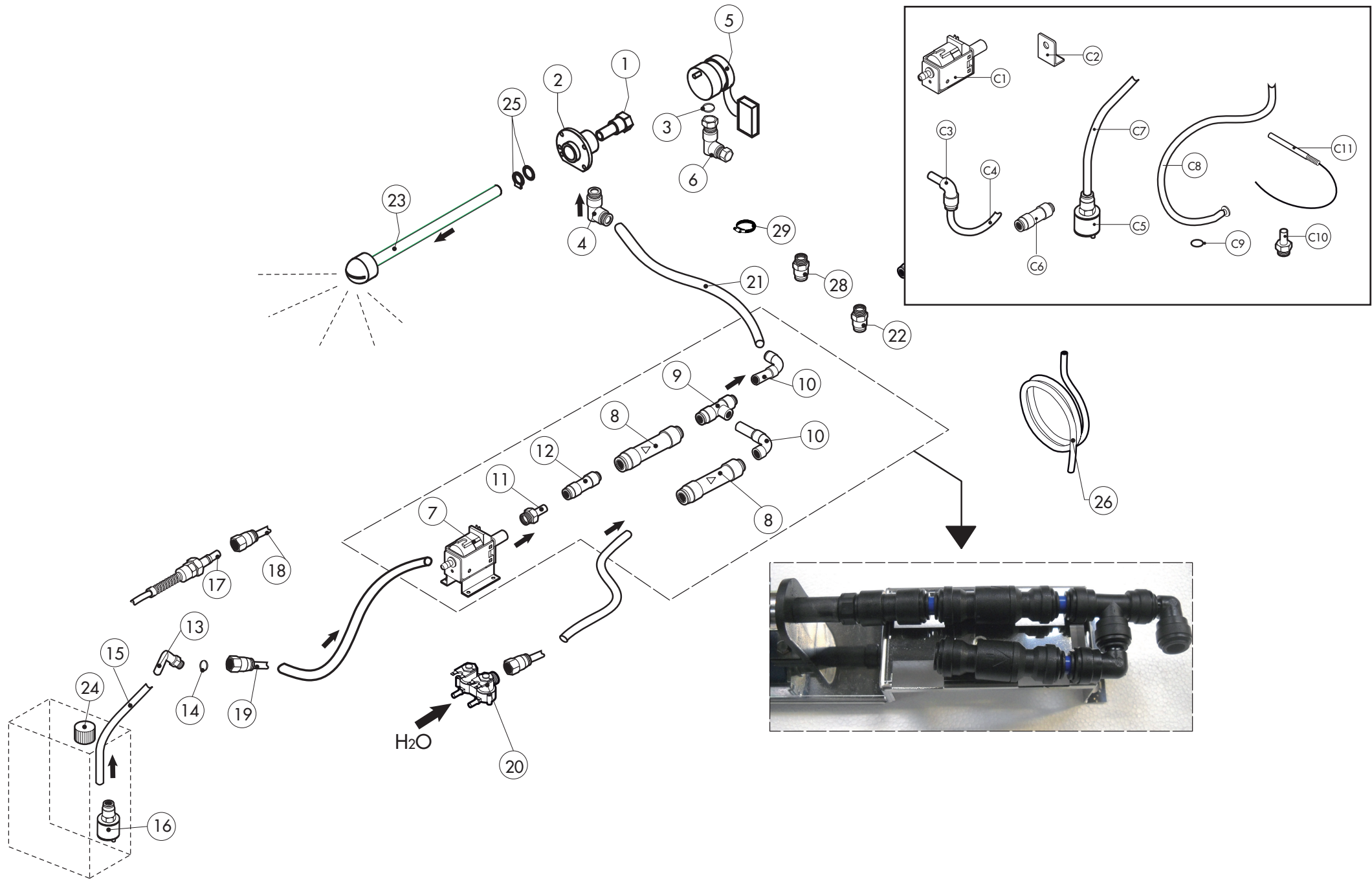

ATTENZIONE: PER ORDINARE I RICAMBI, SPECIFICARE SEMPRE IL MODELLO DI FORNO ED IL NUMERO DI MATRICOLA
ATTENTION: WHEN ORDERING SPARE PARTS, PLEASE ALWAYS SPECIFY THE OVEN MODEL AND THE SERIAL NUMBER

ATTENTION: POUR COMMANDER DES PIECES, MERCI DE SPECIFIER TOUJOURS LE MODELE DU FOUR ET LE NUMERO DE SERIE
ACHTUNG: UM ERSATZTEILE ZU BESTELLEN, BITTE IMMER OFEN-MODELL UND SERIENNUMMER GEBEN.

ed. 0614

POS.	COD.	Pz.	DESCRIZIONE	DESCRIPTION	DESCRIPTION	BESCHREIBUNG	DESCRIPCIÓN
1	R58007000	1	PERNO ROTANTE LAVAGGIO MOB	ROTATING PIVOT	PIVOT TOURNANT	UMLAUFENDE STÜTZE	GOZNE ROTATORIO
2	R58007020	1	FLANGIA LAVAGGIO MOB	WASHING SYSTEM FLANGE	BRIDE BRAS DE LAVAGE	FLANSCH WASCHARMBEFESTIGUNG	PLATINA LAVADO
3	R70010080	1	GUARNIZIONE OR 14x2 Viton DIN 981	GASKETS OR 14x2	OR JOINT	RINGDICHTUNG 14x2	JUNTA OR 14x2
4	R62090663	1	RACCORDO OTTONE NICH.A L C/OGIVA 10X1/4"	ELBOW PIPE FITTING BRASS D.10x1/4"	RACCORDEMENT A COUDE LAITON D 10x1/4"	ELBOW PIPE FITTING BRASS D.10x1/4"	RACOR LATON DE GOMA D.10x1/4"
5	R65090250	1	MOTORID.LAV.SAIA-BURGESS 175022044028-A	WASHING GEARED MOTORS	MOTO-REDUCTEURS DE LAVAGE	GETRIEBEMOTOREN	MOTORREDUCTORES LAVADO
6	R62090633	1	RACCORDO OTTONE CURVO 10/10 C/OGIVA	ELBOW PIPE FITTING BRASS D.10	RACCORDEMENT A COUDE LAITON D 10	WINKELSTUTZEN AUS MESSING D,10	RACOR LATON DE GOMA D.10
7	R65110600	1	POMPA ELETTRON.A PIS.OSC.ET508LAB 2273	POMPE DETERGEANT	DETRGENT PUMP	REINIGERPUMPE	BOMBA DETERGENTE
8	R65110680	2	VALVOLA ANTIRITORNO J.G. 10SCV	ANTI-BACK FLOW	ANTIRETOUR	RUCKFLUSSVERHINDERER	ANTIRETORNO
9	R62090468	1	RACCORDO INTERMEDIO A "T" D.10 PM0210E	T MIDLING PIPE FITTING D.10	RACCORD INTERMEDIAIRE A "T" D.10	MITTELVERBINDUNGSSTUCK D.10 "T"- FORMIG	RACOR INTERMEDIO TIPO "T" D.10
10	R62090528	5	RACC.A GOMITO C/CODOLO 10X10 PM221010E	ELBOW PIPE FITTING (WITH TANG) 10 X 10	COURBE AVEC QUEUE 10x10	WINKELVERBINDUNGSSTUCK 10 X 10 MIT SCHAFT	RACOR DE GOMA CON CODO 10x10
11	R62090608	2	TERMINALE C/CODOLO 8x1/8" PM050811E	8X1/8 END SIDE PIPE FITTING (WITH TANG)	RACCORD AVEC QUEUE 8x1/8"	ENDVERBINDUNGSSTUCK 8 X 1/8" MOT SCHAFT	RACOR TERMINAL CON CODO 8x1/8"
12	R62090618	1	RIDUZIONE INTERMEDIA 10-8 PM201008E	REDUCTION PIPE FITTING	RACCORD DROIT REDUCTION	GERADE ANSCHLUSS-VERKLEINERUNG	RACOR DERECHO REDUCCION
13	R62090678	1	RACC.A GOMITO C/CODOLO 8X8 PM220808E	ELBOW PIPE FITTING (WITH TANG) 8 X 8	COURBE AVEC QUEUE 8x8	WINKELVERBINDUNGSSTUCK 8X8 MIT SCHAFT	RACOR DE GOMA CON CODO 8x8
14	R70010050	4	GUARNIZIONE OR 7,60 X 2,62 OR 3030 NB	JOINT OR 7,60x2,62	OR GASKETS	RINGDICHTUNG 7,60X2,62	JUNTA OR 7,60x2,62
15	R80150020	2	TUBO DETERGENTE PE D.8mm x 6	PE D.8 MM X 6 DETERGENT FLEXIBLE PIPE	TUBE DETERGEANT D. 8x6	ROHRLIETUNG F. REININGER PE D.8MMX6 (2MT)	TUBO DETERGENTE PE D.8mm X 6
16	R65110650	1	VALVOLA DI FONDO PER FILTRO GM.060.35	BOTTOM FILTER	FILTER POUR TUBE DETERGEANT	ANSAUGFILTER F. REINIGUNGSSCHAUCH	VÁLVULA DE FONDO TUBO DEL LIMPIADOR
17	R62090482	1	RACC.RAPIDO MASCHIO X LAVAG. PIPU40-C08M	RAPID MALE PIPE FITTING	RACCORD RAPIDE PARTIE MALE	SCHNELLVVERBINDUNG MANNL	RACOR RAPIDO MACHO
18	R62090638	1	RACC.RAP.FEMM.X LAV.FIL.FEMM PVP40-F1/4	RAPID FEMALE PIPE FITTING	RACCORD RAPIDE PARTIE FEMELLE	SCHNELLVVERBINDUNG	RACOR RAPIDO HEMBRA
19	R62090538	1	RACC.DIR.F.1/4" TUBO6X8 A CALZ. PRCF220008	1/4" FEMALE STRAIGHT PIPE FITTING FOR D.6X8 PIPE	RACCORD DROIT PARTIE FEMELLE 1/4" TUBE 6x8	VERBINDUNGSSTUCK 1/4" WEBL. FUR ROHR D.6X8	RACOR DERECHO HEMBRA 1/4" PARA TUBO D.6x8
20	R65110210	1	E.V. 2 VIE 220V 50HZ X J.G. CON ATTACC	SOLENOID VALVE 220V 50HZ	ELECTROVANNE 220V 50HZ	MAGNETVENTIL 220V 50HZ	ELECTROVALVULA 220V 50HZ
21	R80150000	1	TUBO PE D.10mm x 7 AZZURRO	PE D.10 MM X7 WATER FLEXIBLE PIPE	TUBE FLEXIBLE EAU D. 10x7	WASSERFLEXROHRLEITUNG PE D.10MMX7	TUBO FLEXIBLE AGUA PE D.10mm X 7
22	R62090688	1	RACC.TERMIN.DIR.FIL.CON.8X1/4 NC2500-P	8x1/4 STRAIGHT THREADED TERMINAL PIPE FITTING	RACCORD FILETE DROIT 8x1/4"	ENDVERBINDUNGSSTUCK 8x1/4" GESCHNITTEN	RACOR TERMINAL DERECHO ROSCADO 8x1/4"
23	R58007050	1	TESTA LAVAGGIO MOB+ALBERO L=110 (M_051)	WASHING SYSTEM INNER ASSEMBLY	ENSEMBLE INTERIEUR DU LAVAGE	INNEN WASCHARMBEFESTIGUNG	KIT INTERNO LAVADO
24	R58005060	1	TAPPO TANICA GIALLO x LAVAGGIO	COVER	BOUCHON	ABDECKUNG	TAPON
25	R70045120	1	KIT GUARNIZIONI X LAVAGGIO MOB	GASKETS KIT	ENSEMBLE JOINTS	DICHTUNGSSATZ	KIT JUNTAS
26	R70070080	1	TUBO CARICO ACQUA D.23mm x 13	PIPE	TUBE	LEITUNG	TUBO
27	R62090478	1	RACC. INTERMEDIO A GOMITO D.10 PM0310E	ELBOW PIPE FITTING	COURBE AVEC QUEUE	STUCK MIT SCHAFT	RACOR CON CODO
28	R62090508	1	RACC.TERMIN.DIR.FIL.CON.10X1/4 PM011002E	10X1/4 STRAIGHT THREADED TERMINAL PIPE FITTING	RACCORDEMENT	ENDVERBINDUNGSSTUCK 10 X 1/4" GESCHNITTEN	RACOR
29	R61630011	2	FASCETTE ZINC.12-22/9	METAL CLAMPS 12-22/9	COLLIER DE SERRAGE 12-22/9	VERZINKTE SCHELLEN 12-22/9	ABRAZADERA 12-22/9
C1	R65110620	1	POMPA ELETTRON.A PIS.OSC.HF 230V/50HZ	PUMP	POMPE	PUMPE	POMPA
C2	R65110630	2	SUPPORTO ELLE POMPA HF	PUMP HOLDER	SUPPORT POUR POMPE	GESTELL FUER PUMPE	SOPORTE PARA POMPA
C3	R62090808	1	GOMITO CON CODOLO ø6-ø6 PM220606E	ELBOW PIPE FITTING	COURBE AVEC QUEUE	WINKELVERBINDUNGSSTUCK MIT SCHAFT	RACOR DE GOMA CON CODO
C4	R80150050	1,6m	TUBO PE 6MMX4	WATER FLEXIBLE PIPE	TUBE FLEXIBLE EAU	WASSERFLEXROHRLEITUNG	TUBO FLEXIBLE AGUA
C5	R65110650	1	VALVOLA DI FONDO PER FILTRO GM.060.35	VALVE	DRAINAGE	ABLAUFVENTIL	VALVULA
C6	R62090798	2	RIDUZIONE INTER.DRITTA ø8-ø6 PM200806E	REDUCTION	REDUCTION	VERRINGERUNG	REDUCCION
C7	R80150020	2	TUBO PE 8MMX6 TRASPARENTE	WATER FLEXIBLE PIPE	TUBE FLEXIBLE EAU	WASSERFLEXROHRLEITUNG	TUBO FLEXIBLE AGUA
C8	R11429630	1	TUBO INGRESSO ANTICALCARE BOILER CAL-OUT	CALOUT FLEXIBLE PIPE	TUBE FLEXIBLE POUR CALOUT	CALOUT FLEXROHRLEITUNG	TUBO FLEXIBLE CALOUT
C9	R62070023	1	BICONO PILOTA TUBO D.6 905	BICONE D.6	BICONE D.6	KEGEL D.6	BICONO D.6
C10	R62060223	1	DADO PILOTA TUBO D.6 0903/1	NUT D. 6	ECROU D. 6	MUTTER D.6	DADO D.6
C11	R65324550	1	SONDA LIVELLO CALOUT TL 10/B EL=20 TF=15	LEVEL PROBE	SONDE DE NIVEAU	WASSERSSTANDSFUEHLER	SONDA NIVEL

TAV. D

KME 061 S