

ATTENZIONE: PER TENSIONI SPECIALI, SPECIFICARE SEMPRE IL MODELLO DI FORNO ED IL NUMERO DI MATRICOLA
ATTENTION: FOR SPECIAL VOLTAGES, PLEASE ALWAYS SPECIFY THE OVEN MODEL AND THE SERIAL NUMBER

ATTENTION: POUR TENSIONS SPÉCIALES, MERCI DE SPÉCIFIER TOUJOURS LE MODÈLE DU FOUR ET LE NUMÉRO DE SÉRIE
ACHTUNG: BEI SONDRSPANNUNGEN, BITTE IMMER OFEN-MODELL UND SERIENNUMMER GEBEN.

ed. 0914

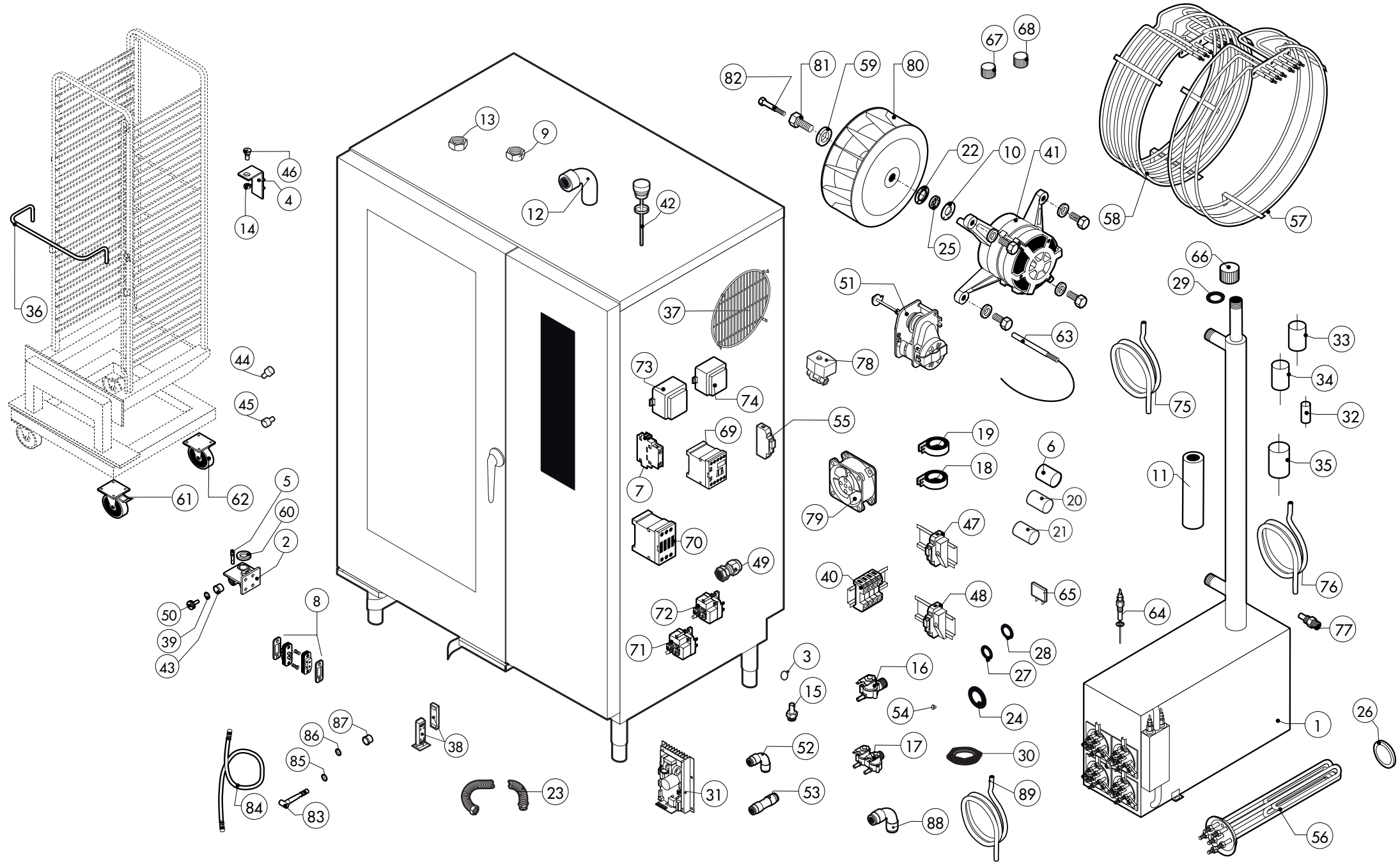

TAV. A

GEM T40 X

ATTENZIONE: PER ORDINARE I RICAMBI, SPECIFICARE SEMPRE IL MODELLO DI FORNO ED IL NUMERO DI MATRICOLA
ATTENTION: WHEN ORDERING SPARE PARTS, PLEASE ALWAYS SPECIFY THE OVEN MODEL AND THE SERIAL NUMBER

ATTENTION: POUR COMMANDER DES PIÈCES, MERCI DE SPECIFIER TOUJOURS LE MODÈLE DU FOUR ET LE NUMÉRO DE SÉRIE
ACHTUNG: UM ERSATZTEILE ZU BESTELLEN, BITTE IMMER OFEN-MODELL UND SERIENNUMMER GEBEN.

ed. 0914

POS.	COD.	Pz.	DESCRIZIONE	DESCRIPTION	DESCRIPTION	BESCHREIBUNG	DESCRIPCIÓN
1	R11214100	1	ASS.BOILER C/CAL-OUT KME202	STEAM GENERATOR ASSEMBLY	CHAUDIERE COMPLETE	DAMPFERZEUGER KOMPLETT	BOILER COMPLETO
2	R11205390	1	ASS.CERNIERA INFERIORE M-V/201-202	LOWER DOOR HINGE	CHARNIERE INFERIEURE PORTE	UNTERES SCHARNIER	BISAGRA INFERIOR
3	R62070023	3	BICONO PILOTA TUBO D.6 905.	BICONE D.6	BICONE D. 6	KEGEL D.6	BICONO D.6
4	R11426830	1	CERNIERA SUPER. PORTA SR.2013	UPPER DOOR HINGE	CHARNIERE SUPERIEURE PORTE	OBERES SCHARNIER	BISAGRA SUPERIOR
5	R58002540	1	CHIAVETTA X PERNO C/FERMO PORTM-V/120-22	DOOR PIVOT SUNK KEY	CLAVETTE POUR CHEVILLE PORTE	KEIL F. TUERSTIFT	LLAVE PARA PERNO PUERTA
6	R65190220	1	CONDENSATORE 0,47µF 275V	CAPACITOR	CONDENSATEUR	KONDENSATOR	CONDENSADOR
7	R65140430	2	CONT.AUS. 1L+1R 3RH1921-1EA11 SIEMENS	AUX.CONTACT 1L+1R	CONTACT AUXILIAIRE 1L+1R	ZUSÄTZLICHER KONTAKT 1L+1R	CONTACTO AUXILIAR 1L+1R
8	R65260752	1	CONTATTO PER LUCI SR.2014+FORNI A PAVIM.	LAMPS CONTACT BLOCK	CONTACT ECLAIRAGE	LICHTKONTSCHALTER	CONTACTO PARA LUZ
9	R65240040	1	CONTRODADO PER RACCORDO 107 Z/29	CABLE GLAND LOCK NUT	CONTRE-ECROU POUR RONDELLE FIXATION	MUTTER	CONTRODADO PASACABLE
10	R58003850	2	CONTROFLANGIA GUARN. GRANDE	MOTOR GASKET BRASS COUNTER FLANGE	CONTRE- BRIDE JOINT MOTEUR	GEGENFLANSCH F. MOTORDICHTUNG	CONTRABRIDA JUNTA MOTOR
11	R80010110	1	COPPELLA LANA VETRO 76x30mm SCHALEN	ISOLATION	ISOLATION	AISLAMIENTO	DAMMUNG
12	R62280038	1	CURVA C/MORSET.HTS-HTSW X TUBO D.50 D.50X	CURVE WITH TERMINAL	COURBE AVEC BORNIER	KURVE MIT KLEMM	CURVA CON REGLETERA
13	R58004030	4	DADO INOX 1"1/4X8 M/110-210-220 031010	NUT	ECROU	MUTTER	TUERCA
14	R58004050	1	DADO PER PERNO CERNIERA REG. M/106-220	NUT FOR UPPER DOOR HINGE	ECROU CHEVILLE CHARNIERE SUPERIEURE	MUTTER F. OBERES SCHARNIERSTIFT	TUERCA PARA PERNO BISAGRA SUPERIOR
15	R62060223	3	DADO PILOTA TUBO D.6 0903/1.	NUT D.6	ECROU D. 6	MUTTER D.6	DADO D.6
16	R65110200	1	E.V. 1 VIA 220V 50HZ X J.G.CON ATTACC	SOLENOID VALVE	ELECTROVANNE	MAGNETVENTIL	ELECTROVALVULA
17	R65110210	1	E.V. 2 VIE 220V 50HZ X J.G.CON ATTACC	SOLENOID VALVE	ELECTROVANNE	MAGNETVENTIL	ELECTROVALVULA
18	R65280520	1	FERRITE TOROIDALE FT63	FERRITE FT63	FERRITE FT63	FERRIT FT63	FERRITA FT63
19	R65280480	2	FERRITE TOROIDALE FT25	FERRITE FT25	FERRITE FT25	FERRIT FT25	FERRITA FT25
20	R65280240	1	FILTRO FLC470501F	INTERFERENCE SUPPRESSOR	FILTRE ANTIPARASITES	STOERSCHUTZFILTER	FILTRO
21	R65280250	1	FILTRO DI POTENZA RC 3/4KW-PA 575V	SUPPRESSOR	FILTRE	FILTER	FILTRO
22	R58003840	2	FLANGIA GUARN. GRANDE	MOTOR GASKET BRASS FLANGE	BRIDE JOINT MOTEUR	FLANSCH F. MOTORDICHTUNG	BRIDA JUNTA MOTOR
23	R62180022	1	FLEX H2O L=10-20CM M/F3/4" INOX DADO OT.	FLEXIBLE PIPE	TUBE FLEXIBLE	FLEXROHR	TUBO FLEXIBLE
24	R70010030	1	GUARNIZIONE OR 6,07 X 1,78 SILICONE	GASKET OR 6,07 X 1,78	JOINT OR 6,07 X 1,78	RINGDICHTUNG OR 6,07 X 1,78	JUNTA OR 6,07 X 1,78
25	R70020050	2	GUARNIZIONE MARK IV MLA 2400.02.05	GASKET	JOINT	RINGDICHTUNG	JUNTA
26	R70045010	1	GUARNIZIONE NERA RESISTENZA BOILER	GASKET	JOINT	RINGDICHTUNG	JUNTA
27	R70010210	1	GUARNIZIONE OR NBR 70 18,72x2,62 C.3075	GASKET OR 18,72x2,62	JOINT OR 18,72x2,62	RINGDICHTUNG OR 18,72x2,62	JUNTA OR 18,72x2,62
28	R65070230	1	GUARNIZIONE PER TERM.SIC.CAMERM/106-110	GASKET	JOINT	RINGDICHTUNG	JUNTA
29	R70050140	1	GUARNIZIONE X TAPPO BOYLER PLAST. G40015	GASKET	JOINT	RINGDICHTUNG	JUNTA
30	R70010120	1	GUARNIZIONE SILICONE ROSSO 90X90X3	RED GASKET	JOINT ROUGE	ROTEN DICHTUNG	JUNTA ROJA
31	R65140890	2	INVERTER 0.5KW MOT.INF.A001M005XS X RIC	INVERTER	INVERSEUR	INVERTER	INVERSOR
32	R70060080	1	MANICOTTO SILICONE D.13X18X80	SILICON SLEEVE	SILICONE SLEEVE	SILIKONHÜLLE	FUNDA DE SILICONA
33	R70060020	1	MANICOTTO SILICONE D.30X35X9 TAPPO SFIA	SILICON SLEEVE	SILICONE SLEEVE	SILIKONHÜLLE	FUNDA DE SILICONA
34	R70060040	2	MANICOTTO SILICONE D.50X50X3	SILICON SLEEVE	SILICONE SLEEVE	SILIKONHÜLLE	FUNDA DE SILICONA
35	R70060050	1	MANICOTTO SILICONE D.60	SILICON SLEEVE	SILICONE SLEEVE	SILIKONHÜLLE	FUNDA DE SILICONA
36	R10457840	1	MANIGLIA CARRELLO KS/021-040	HANDLE FOR TROLLEY	POIGNÉE POUR CHARIOT PORTE POELES	HANDGRIFF-LAUFKATZE	MANIJA CARRO PORTABANDEJAS
37	R75300070	2	MASCHERINA VENTILATORE D.350 N/S101 2014	FAN GUARD GRID D.350	GRILLE VENTILATEUR D.350	VENTILATORSCHUTZGITTER D.350	REJILLA VENTILADOR D.350
38	R65265100	1	MICRO PORTA MAGNETICO COMPLETO RIC.	DOOR SWITCH	MICRO PORTE	TUERSCHALTER	MICRO PUERTA
39	R61620091	16	MOLLA A TAZZA D.14/6,4X0,8 C70	BELLEVILLE WASHER Ø 14/6.4	RESSORT A DISQUE Ø 14/6.4	TELLERFEDER Ø 14/6.4	MUELLE A DISCO Ø 14/6.4
40	R65220310	1	MORSETTIERA LX5N (TIPO 5) NEW C/TERRA PASS	TERMINAL BOARD	BORNIER	KLEMMLEISTE	REGLETERA
41	R65040530	2	MOTORE KW 055 F3 4P 3039 200-440V I	MOTOR	MOTEUR	MOTOR	MOTOR
42	R10100140	1	TAPPO SFIATO COMPLETO M/106.-220 FINO ALLA SETTIMANA 26/2014	COVER UNTIL WEEK 26/2014	BOUCHON ÉLIMINÉ DU SEMAINE 26/2014	ABDECKUNG BIS WOCHE 26/2014	TAPON ELIMINATO DEL SEMANA 26/2014
42	R58006690	1	TAPPO SFIATO COMPLETO SERIE 2014 DALLA SETTIMANA 27/2014	COVER FROM WEEK 27/2014	BOUCHON DU SEMAINE 27/2014	ABDECKUNG VOM WOCHE 27/2014	TAPON DEL SEMANA 27/2014
43	R58002550	1	PATTINO FERMO PORTA M-V/120 - 220	DOOR RETAINER GUIDE SHOE	PATIN ARRET PORTE	GLEITSTUECK F. TUEARRETIERUNG	PATILLA CIERRE PUERTA

TAV. A

GEM T40 X

ATTENZIONE: PER ORDINARE I RICAMBI, SPECIFICARE SEMPRE IL MODELLO DI FORNO ED IL NUMERO DI MATRICOLA
ATTENTION: WHEN ORDERING SPARE PARTS, PLEASE ALWAYS SPECIFY THE OVEN MODEL AND THE SERIAL NUMBER

ATTENTION: POUR COMMANDER DES PIÉCES, MERCI DE SPECIFIER TOUJOURS LE MODELE DU FOUR ET LE NUMERO DE SERIE
ACHTUNG: UM ERSATZTEILE ZU BESTELLEN, BITTE IMMER OFEN-MODELL UND SERIENNUMMER GEBEN.

ed. 0914

POS.	COD.	Pz.	DESCRIZIONE	DESCRIPTION	DESCRIPTION	BESCHREIBUNG	DESCRIPCIÓN
44	R58003140	3	PERNO AGGANCIAMENTO DEFLETTORE	FAN GUARD PANEL PIN	PIVOT DEFLECTEUR	BOLZEN FÜR LUFTLEITBLECH	PERNO CIERRE DEFLECTOR
45	R58003110	3	PERNO FISSAGGIO DEFLETTORE	FAN GUARD PANEL PIN	PIVOT DEFLECTEUR	BOLZEN FÜR LUFTLEITBLECH	PERNO CIERRE DEFLECTOR
46	R58002150	1	PERNO SUP.CERNIERA REG. M/106-220	UPPER HINGE PIN	CHEVILLE CHARNIERE SUPERIEURE	OBERES SCHARNIERSTIFT	PERNO SUPERIOR BISAGRA
47	R65210020	4	PORTAFUSIBILE BARRA DIN 5x20	FUSE CARRIER	PORTE-FUSIBLE	SICHERUNGSHALTER	PORTAFUSIBILE
48	R65210050	2	PORTAFUSIBILE BARRA DIN 6,3x32	FUSE CARRIER	PORTE-FUSIBLE	SICHERUNGSHALTER	PORTAFUSIBILE
49	R65240030	1	PRESSACAVO PG 107 Z/29 (RACCORDO)	FAIRLEAD	PRESSE CABLE	ZUGENTLASTUNG	PRENSACABLES
50	R58002560	1	PRESSORE FERMO PORTA M-V/120-220	SCREW FOR LOWER DOOR HINGE	VIS POUR CHARNIERE INFERIEURE	DRUCKSCHRAUBE F. UNTERERS TUERSCHARNIER	TORNILLO PARA BISAGRA INFERIOR
51	R65090220	1	PROGRAMMAT. 1 CAMME V220/50HZ 1 CIRC.	DAMPER SYSTEM	SORTIE EVAPORATION MOUFLE	DAMPFABLASS-STELLMOTOR	MOTOR RESPIRADERO COMPLETO
52	R62090478	1	RACC. INTERMEDIO A GOMITO D.10 PM0310E	ELBOW PIPE FITTING	COURBE AVEC QUEUE	STUCK MIT SCHAFT	RACOR CON CODO
53	R62090458	1	RACC. INTERMEDIO DIRITTO D.10 PM0410E	PIPE FITTING	COURBE	STUCK	RACOR
54	R65110510	1	REGOL. PORTATA ROSSO ALPHATECH. 1.5LT/H	1.5 LT/H WATER FLOW REDUCER	REGULATUER DE DEBIT 1.5 LT.	DURCHFLUSSMONDERER 1.5 L/STD.	REGULADOR DE CAUDAL 1.5 LT.
55	R65170050	1	RELE' 4052 240V AC 8/5A	RELAY	RELAIS	RELAIS	RELE
56	R65020421	4	RESISTENZA 15000W 230V BOILER ME/220 TRI	STEAM GENERATOR HEATING ELEMENT 15000W	RESISTANCE CHAUDIERE 15000W	BOILER HEIZKOERPER 15000W	RESISTENCIA BOILER 15000W
57	R65011250	2	RESISTENZA CIRC.15000W 230V CAMME/VE 210	CHAMBER HEATING ELEMENT 15000W	RESISTANCE MOUFLE 15000W	GARRAUM HEIZKOERPER 15000W	RESISTENCIA CAMARA 15000W
58	R65011310	2	RESISTENZA CIRC.15000W 230V CAMME-VE/110	CHAMBER HEATING ELEMENT 15000W	RESISTANCE MOUFLE 15000W	GARRAUM HEIZKOERPER 15000W	RESISTENCIA CAMARA 15000W
59	R58004010	2	ROND. FISS. VENTOLA D 30/12.5	FAN WASHER Ø 30/12.5	RONDELLE TURBINE Ø 30/12.5	UNTERLEGSCHIEBE Ø 30/12.5	ARANDELA FIJACION TURBINA Ø 30/12.5
60	R58002570	1	RONDELLA 30/15X3 M-V/120-220	WASHER	RONDELLE	UNTERLEGSCHIEBE	ARANDELA
61	R69090360	2	RUOTA GIR. DOPPIA C/FR. D.100 (5945UAP100)	WHEEL	ROUE	RAD	RUEDA
62	R69090350	2	RUOTA GIR. DOPPIA D.100 (5940UAP100)	WHEEL	ROUE	RAD	RUEDA
63	R65320220	3	SONDA "K" 6X80 1,5ML. TESTA RASTREM.20mm	PROBE "K" 6X80 1,5ML.	SONDE "K" 6X80 1,5ML.	FUEHLER "K" 6X80 1,5ML.	SONDA "K" 6X80 1,5ML.
64	R65320010	2	SONDA LIVELLO TL 10/B	LEVEL PROBE	SONDE DE NIVEAU	WASSERSSTANDSFUEHLER	SONDA NIVEL
65	R65147110	8	SURGE SUPPRESSOR (SNABBER) 3RT1926-1CD00	SURGE SUPPRESSOR	PARAFOUDRE	ÜBERSPANNUNGSABLEITER	PROTECTOR DE SOBRETENSIÓN
66	R69150110	1	TAPPO FEMMINA G 1"1/4 PP+25%FV NERO	COVER	BOUCHON	ABDECKUNG	TAPON
67	R62100108	1	TAPPO ROSSO D.10 (PM0810R)	RED COVER	ROUGE BOUCHON	ROTEN ABDECKUNG	TAPON ROJO
68	R58005070	1	TAPPO TANICA VERDE x CALOUT	GREEN COVER	VERT BOUCHON	GRÜNEN ABDECKUNG	TAPON VERDE
69	R65140380	1	TELERUTTORE 3RT1016-1AP02	CONTACTOR	CONTACTEUR	SCHUETZ	CONTACTOR
70	R65140400	12	TELERUTTORE 3RT1025-1AL20 SIEMENS	CONTACTOR	CONTACTEUR	SCHUETZ	CONTACTOR
71	R65070350	1	TERMOSTATO SICUR. 360°C -25K 55.32572.8	THERMOSTAT	THERMOSTAT	THERMOSTAT	TERMOSTATO
72	R65070081	1	TERMOSTATO SICUR. BOILER M/1065532522852	THERMOSTAT	THERMOSTAT	THERMOSTAT	TERMOSTATO
73	R65180420	2	TRASF.RE 20VA 0-220-240/12V MOD.163.16	TRANSFORMER 20VA	TRANSFORMATEUR 20VA	TRANSFORMATOR 20VA	TRANSFORMADOR 20VA
74	R65180430	1	TRASF.RE 40VA 0-220-240/12V MOD.163.82	TRANSFORMER 40VA	TRANSFORMATEUR 40VA	TRANSFORMATOR 40VA	TRANSFORMADOR 40VA
75	R80150000	3	TUBO PE 10MMX7 AZZURRO PM950612E	BLUE PIPE	TUBE	LEITUNG	TUBO
76	R80120060	5	TUBO SILIC. TRASP. SR60/TR 7/12.	PIPE	PIPE	LEITUNG	TUBO
77	R58006160	2	UGELLO COND. D.0,8 CODOLO CIL.10	NOZZLE	BEC	DÜSE	BOQUILLA
78	R65110560	1	VALV. A SFERA MOTOR. 220V 3/4"	STEAM GENERATOR DRAIN MOTORIZED VALVE	DRAINAGE CHAUDIERE	BOILERABLAUFVENTIL	VALVULA DE BOLA MOTORIZADA
79	R65060050	4	VENTILATORE COMPATTO D.120 4715MS 23T	COMPONENTS VENTILATION MOTOR D.120	MOTEUR DE REFROIDISSMENT D.120	ABKÜLUNGS MOTOR D.120	MOTOR DE ENFRIAMIENTO D.120
80	R75400440	2	VENTOLA D.350X114/12 50HZ P.D.	FAN	TURBINE	LUEFTERRAD	PALA VENTILADOR
81	R58004000	2	VITE FISS.VENTOLA M/12X1.5 SX	FAN SCREW M12x1.5 SX	VIS DE BLOCAGE TURBINE M12x1.5 SX	VENTILATORSCHRAUBE M12x1.5 SX	TORNILLO FIJACION TURBINA M12x1.5 SX
82	R61020562	2	VITE TE A2 M 6X55 UNI 5737	MOTOR SCREW TE A2 M6x55	VIS DE BLOCAGE MOTEUR TE A2 M6x55	MOTORSCHRAUBE TE A2 M6x55	TORNILLO MOTOR TE A2 M6x55
83	R62200028	1	LANCIA DI LAVAGGIO SENZA TUBO	SHOWER HANDLE	POIGNEE DOUCHETTE	GRIFF F. HANDBRAUSE	MANGO DUCHA
84	R62200058	1	GOMMA 1/2"X1/2"X2.5M LANCIA L.2500mm	FLEXIBLE PIPE SHOWER	TUBE FLEXIBLE DOUCHETTE	SCHEAUCH FUER HANDBRAUSE	TUBO FLEXIBLE DUCHA
85	R70030040	2	GUARNIZIONE D.16X24 3/4 GOMMA.	GASKET D.16X24 3/4	JOINT D.16X24 3/4	DICHTUNG D.16X24 3/4	JUNTA D.16X24 3/4
86	R70030030	1	GUARNIZIONE D. 11X19 1/2"	GASKET D. 11X19 1/2"	JOINT D. 11X19 1/2"	DICHTUNG D. 11X19 1/2"	JUNTA D. 11X19 1/2"
87	R69180300	1	SUPPORTO IN PLAST. X DOCCIONE ESTERNO	HOLDER	SUPPORT	HALTERUNG	SOPORTE
88	R62090918	2	RACC.INT.A GOMITO D.10 SPEEDFIT PEM0310W DALLA SETTIMANA 28/2014 (7/7/2014)	WHITE ELBOW PIPE FITTING D.10 FROM WEEK 28/2014 (7/7/2014)	COURBE AVEC QUEUE DU SEMAINE 28/2014 (7/7/2014)	STUCK MIT SCHAFT VOM WOCHEN 28/2014 (7/7/2014)	RACOR CON CODO DEL SEMANA 28/2014 (7/7/2014)
89	R80150060	2,3 m	TUBO PEX-B 10MM ROTOLO 100MT 10BPEX-100C DALLA SETTIMANA 28/2014 (7/7/2014)	PIPE FROM WEEK 28/2014 (7/7/2014)	TUBE DU SEMAINE 28/2014 (7/7/2014)	LEITUNG VOM WOCHEN 28/2014 (7/7/2014)	TUBO DEL SEMANA 28/2014 (7/7/2014)

TAV. A

GEM T40 X

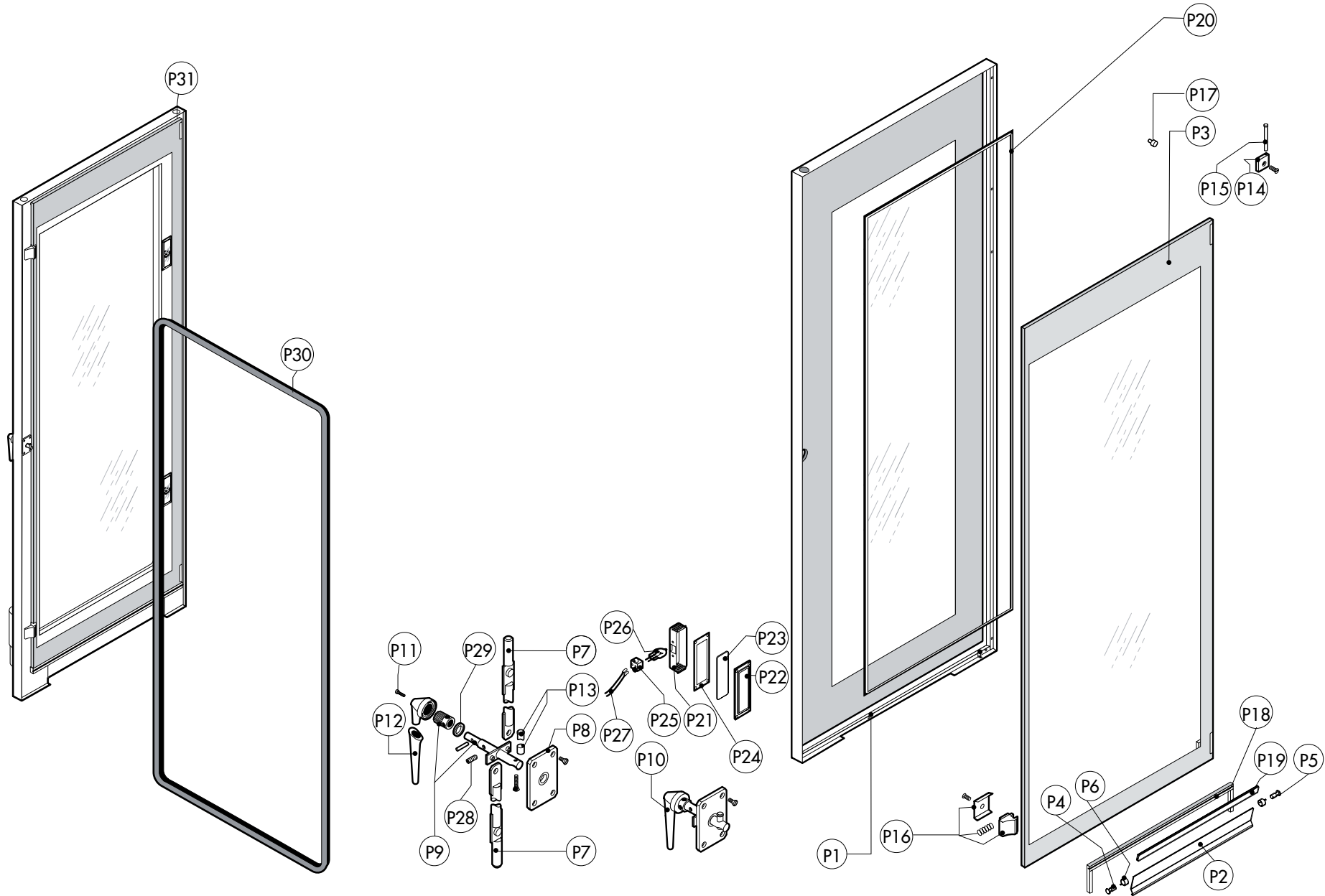

POS.	COD.	Pz.	DESCRIZIONE	DESCRIPTION	DESCRIPTION	BESCHREIBUNG	DESCRIPCIÓN
P1	R11214060	1	PORTA ESTERNA K_202	EXTERNAL DOOR	PORTE D'EXTERNAL	AUSSENTÜR	PUERTA EXTERNA
P2	R11437930	1	BANDELLA DI TAMPONAMENTO K_202	CLOSING PLATE	TÔLE DE FERMETURE	VERSCHLUBLEISTE	PLACA DE CIERRE
P3	R71201870	1	VETRO INTERNO PORTA K_201-202	INNER DOOR GLASS	VERRE INTERIEUR PORTE	INNERES TÜRGLAS	VIDRIO INTERNO PUERTA
P4	R58006861	2	FULCRO X BANDELLA INS. MOLLA	CLOSING PLATE RORAZIONE PIVOT	AXE ROTATION TÔLE DE FERMETURE	DREH	PIVOTE DE CIERRE DE LA PLACA RORAZIONE
P5	R58006910	2	FULCRO FISSAGGIO BANDELLA	PIVOT	AXE	DREHBOLZEN F.VERSCHLUBLEISTE	PIVOTE
P6	R65491250	1	KIT MOLLE BANDELLA TAMPONAMENTO	CLOSING PLATE SPRING ASSEMBLY	KIT RESSORTS TÔLE DE FERMETURE	FEDERSATZ F.VERSCHLUBLEISTE	KIT RESORTE DE PLACA DE CIERRE
P7	R11207670	2	ASS.ASTINA AZ. PUNTO K_201-202	ROD	CREMAILLÈRE	VERSCHLUSSTANGE	EJE
P8	R03200970	1	ASS.FLANGIA BOCCOLA POST.	DOOR LOCK REAR FLANGE	FLASQUE POSTERIEUR PORTE	FLANSCH	BRIDA SOPORTE POSTERIOR
P9	R11205340	1	ASS.PERNO MANIGLIA M-V/201-202	DOOR HANDLE PIN	AXE MANOEUVRE	SCHLIESSNASE AM TUERGRIF	PERNO MANETA
P10	R11100312	1	GRUPPO CHIUSURA COMPLETA G_T21-T40 2012	DOOR CATCH KIT	ENSAMBLE FERMETURE PORTE	VERSCHLUSSSATZ	MANIJA DE LA PUERTA
P11	R69010710	1	TAPPO MAN. GRIGIA GR.6303 C/ANELLO CROM.	DOOR HANDLE	POIGNEE DE PORTE	GRIFFKORPUS	CUERPO MANETA
P12	R69010820	1	MANIGLIA GRIGIA GR.6303 VERS.2011	HANDLE	POIGNEE	TUERGRIF	MANGO MANETA
P13	R58004781	1	GANCIO PERNO MANIGLIA C/NOTT. M/120-220	DOOR HANDLE HOOK	DECLIC AXE MANOEUVRE	HAKEN F. TUERGRIF	GANCHO PERNO MANETA
P14	R58001760	2	CERNIERA FISSA VETRO SR2000	HINGE	CHARNIERE	SCHARNIER	BISAGRA
P15	R58001770	2	PERNO CERNIERA VETRO SR2000	INNER GLASS HINGE PIN	PIVOT CHARNIERE VERRE INTERIEUR	SCHARNIERBOLZEN F. INNENSCHIEBE	PERNO BISAGRA VIDRIO INTERNO
P16	R58001780	2	FERMO VETRO PORTA P2000	INNER GLASS CATCH KIT	ENSEMBLE ARRET VERRE INTERIEUR	VERSCHLUSSSATZ F. INNENSCHIEBE	KIT FIJACION VIDRIO INTERNO
P17	R70050180	9	DISTANZIALE VETRO 15x8 SIL.55SH M4x12 A2	THICKNESS	EPAISSEUR	DICKE	ESPEJOR
P18	R70044362	1	GUARNIZIONE BATTUTA CAR.C/TAMP.K_202	GASKET	JOINT	DICHTUNG	JUNTA
P19	R80100910	0,4	PROFILO GUARNIZIONE BANDELLA	CLOSING PLATE GASKET	JOINT TÔLE DE FERMETURE	DICHTUNG F.VERSCHLUBLEISTE	JUNTA PARA PLACA DE CIERRE
P20	R80100100	3,58	PROFILO GUARN.2 CRISTALLI	GASKET	JOINT	DICHTUNG	JUNTA
P21	R11401440	2	CALOTTA LAMPADA SR.2000	LAMP COVER	CALOTTE DE PROJECTEUR	LAMPENKALOTTE	CUBIERTA LAMPARA
P22	R11401450	2	FLANG.STAMP.VETRO LAMP. SR2000.	GLASS HOLDER LAMP FLANGE	BRIDE ARRET-VERRE ECLAIRAGE	FLANSH F.LAMPENVERGLASUNG	TAPA CRISTAL LAMPARA
P23	R71500150	2	VETRO LAMPADA P2000	GLASS LAMP	VERRE PROTECTION LAMPE	LAMPEGLAS	VIDRIO LAMPARA
P24	R70044200	2	GUARNIZIONE VETRO LAMPADA P2000	LAMP GASKET	JOINT VERRE ECLAIRAGE	LAMPENDICHTUNG	VIDRIO CUBRELAMPARA
P25	R65270450	2	PORTAL. STUCCHI ART.216	LIGHT SOCKET	DOUILLE	LICHTKONTSCHALTER	PORTALAMPARA PARA LAMPARA HALOGENA
P26	R65270020	2	LAMPADA ALOGENA 20W 12V G4 49040	LIGHT 20W 12V G4	LAMPE 20W 12V G4	LAMPENHALTERUNG	LAMPARA HALOGENA 20W 12V G4
P27	R66110330	1	CABLAGGIO LUCI PORTA M-V/201-202	DOOR LAMPS CABLE SET	CABLES ECLAIRAGE PORTE	VERDRAHTUNG TURBELEUCHTUNG	CABLEADO LUCES PUERTA
P28	R61090052	1	VITE STEI M6x16	GRUB SCREW M6x16	VIS SANS TÊTE M6x16	SENKKOPFSCHRAUBE M6x16	TORNILLO SIN CABEZA M6X16
P29	R61600031	2	ANELLO ELASTICO RADIALE D.3,2 UNI 7434	ELASTIC RING	ANNEAU ÉLASTIQUE	ELASTISCHER RING	ANILLO ELASTICO
P30	R70044920	1	TELAIO GUARN. PORTA K_202	FRONT GASKET	JOINT FACADE	DICHTUNG DER FRONTSEITE	JUNTA FRONTAL
P31	R11103720	1	PORTA COMPLETA G_T40 2012	DOOR ASSEMBLY	PORTE COMPLETE	TUER KOMPLETT	PUERTA COMPLETA

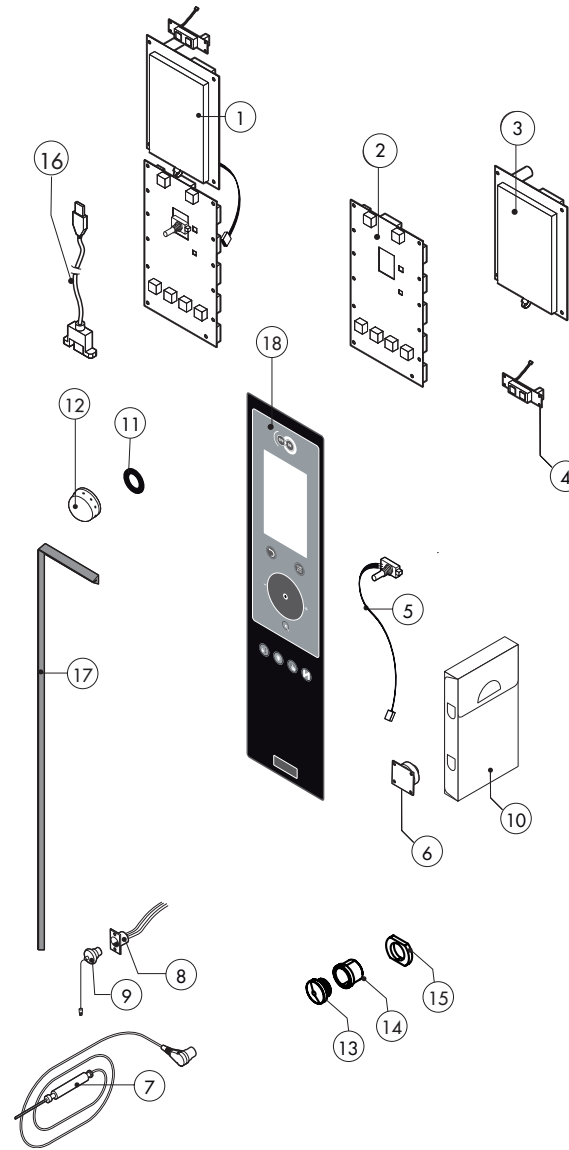

POS.	COD.	Pz.	DESCRIZIONE	DESCRIPTION	DESCRIPTION	BESCHREIBUNG	DESCRIPCIÓN
1	R65301900	1	SCHEDA "X" 2006 COMPLETA	CONTROL PANEL PC BOARD "X"	PLATINE ÉLECTRONIQUE COMPLÈTE "X"	STEUERPLATINE KOMPLETT "X"	PLACA COMPLETA "X"
2	R65301910	1	SCHEDA BASE POTENZA TOP LCD "X" Sr.2006	MAIN PC BOARD "X"	FICHE PANNEAU PRINCIPAL "X"	HAUPTPLATINE "X"	PLACA BASE "X"
3	R65301920	1	SCHEDA DISPLAY TOP LCD "X" Sr.2006	DISPLAY PC BOARD "X"	PLATINE ÉLECTRONIQUE DISPLAY "X"	DISPLAYPLATINE "X"	PLACA DISPLAY "X"
4	R65301930	1	SCHEDA ON-OFF TOP LCD "X" Sr.2006	ON-OFF BOARD "X"	ON-OFF PANNEAU "X"	ON-OFF PLATINE "X"	ON-OFF PLACA "X"
5	R65301940	1	ENCODER LCD "X" SR.2006	FRONT PC BOARD ENCODER	ENCODER PLATINE	ENCODER F. PLATINE	ENCODER PLACA ELECTRONICA
6	R65301960	1	SCHEDA BUZZER TOP LCD "X" Sr.2006	PC BOARD BUZZER	SONNERIE PLATINE	PLATINENSUMMER	ZUMBADOR PLACA ELECTRONICA
7	R65321102	1	SONDA AL CUORE K 4 PUNTI 6 PIN.IMP.2012	CORE TEMPERATURE PROBE	SONDE A COEUR	KERNTEMPERATURFUEHLER	SONDA AL CORAZON
8	R65321110	1	CONNETTORE FEMM. S/CUORE 6 PIN	CORE TEMPERATURE PROBE FEMALE CONNECTOR	CONNECTEUR FEMELLE POUR SONDE A COEUR	STECKDOSE F. KERNTEMPERATURFUEHLER	CONNECTOR HEMBRA PARA SONDA AL CORAZON
9	R65321020	1	TAPPO X CONNETTORE 4 PIN.	COVER FOR CONNECTOR	BOUCHON POUR CONNECTEUR	ABDECKUNG STECKDOSE	TAPON PARA CONECTOR
10	R86020400	1	VALIGETTA X SONDA AL CUORE TRASPARENTE	CORE TEMPERATURE PROBE BOX	PETITE VALISE SONDE A COEUR	TASCHE F. KERNTEMPERATURFUEHLER	ESTUCHE DE SONDA AL CORAZON
11	R70010250	1	GUARNIZIONE OR 17,17 X 1,78 NBR-70	GASKETS OR 17,17 X 1,78	JOINT OR 17,17 X 1,78	RINGDICHTUNG OR 17,17 X 1,78	JUNTA OR 17,17 X 1,78
12	R69030250	1	MANOPOLA ENCODER D.60	KNOB KIT	POIGNEE COMMANDE	DREHKNOPF	PULSADOR MANETA
13	R65321290	1	ASS.TAPPO PER PRESA USB 2012	COVER	BOUCHON	ABDECKUNG	TAPON
14	R65321250	1	BOCCOLA PER PRESA USB 2012	BUSH	DOUILLE	BUSCH	CASQUILLO
15	R58004380	1	DADO PER PRESA USB 2012	NUT	ECROU	MUTTER	TUERCA
16	R65010350	1	CAVO COLL. SCHEDA/PRESA USB HEART L=750	PC BOARD CONNECTION USB	CABLE USB POUR LA PLATINE	REIHENKABLE USB FÜR PLATINEVERBINDUNG	CABLE USB CONEXIÓN FICHA
17	R80100100	2,2m	PROFILO GUARN. NERO 2 CRISTALLI DIS.031005	GASKET	JOINT	DICHTUNG	JUNTA
18		1	TASTIERA	PLATE	PLAQUE	BEDIENUNGSFOLIE	TARJETA

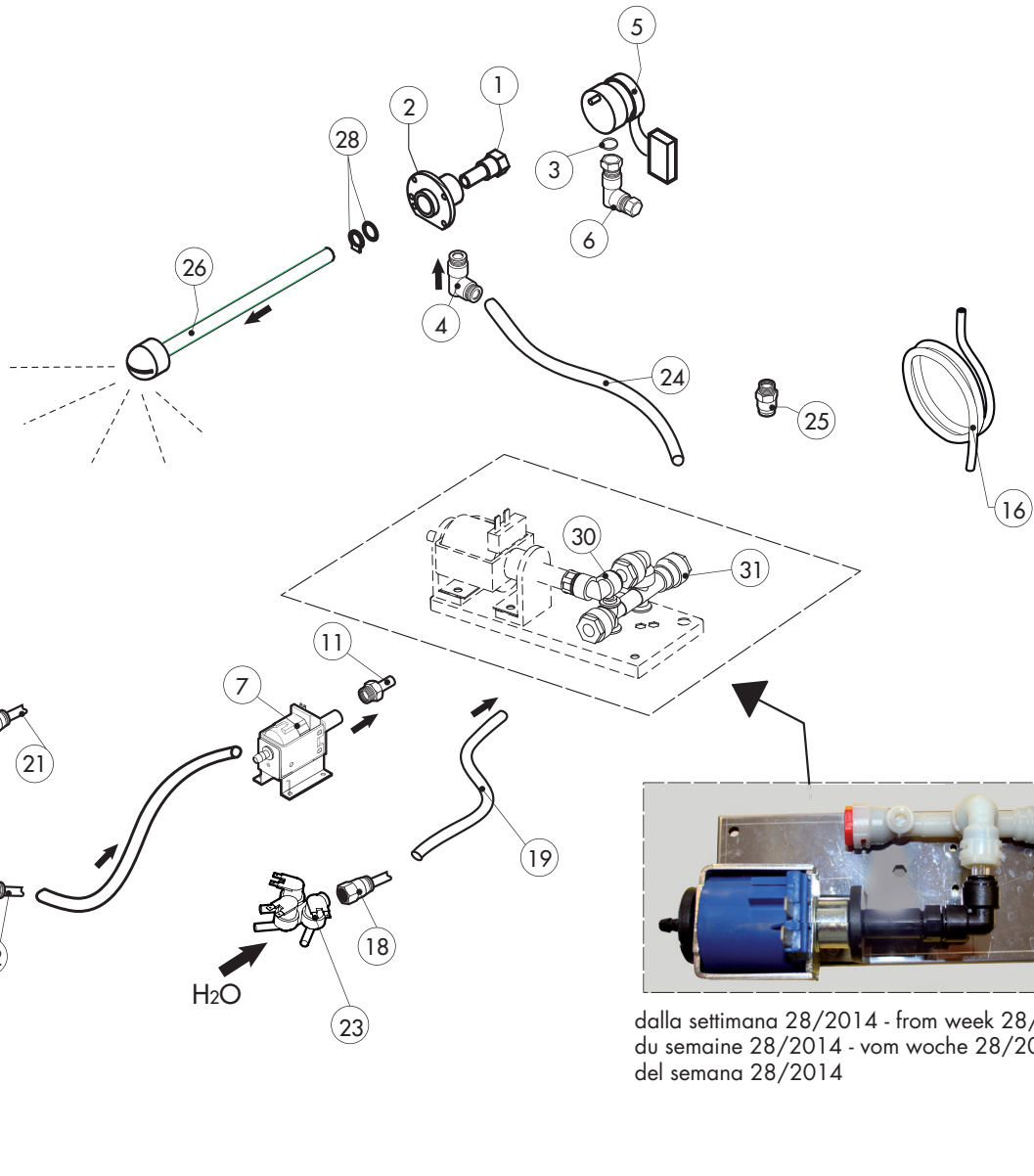
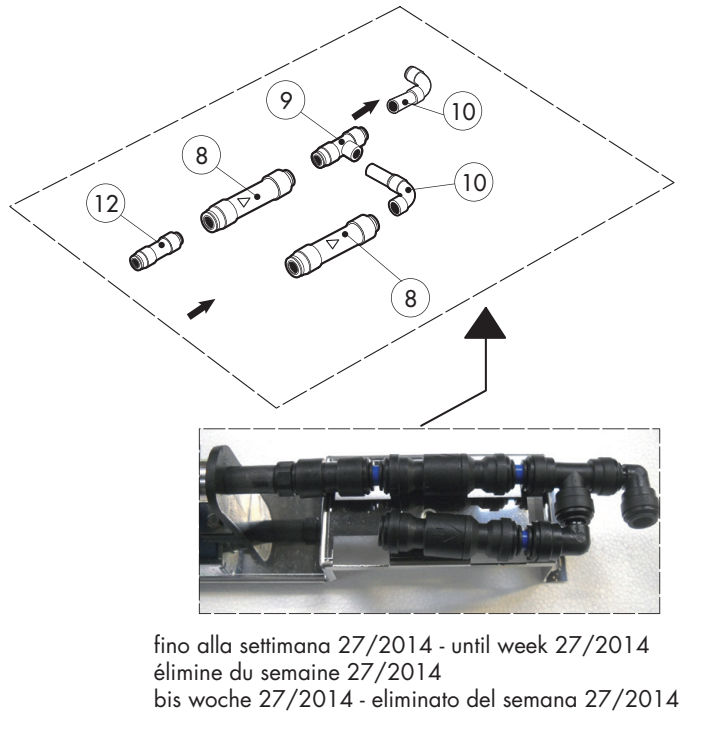

ATTENZIONE: PER ORDINARE I RICAMBI, SPECIFICARE SEMPRE IL MODELLO DI FORNO ED IL NUMERO DI MATRICOLA
ATTENTION: WHEN ORDERING SPARE PARTS, PLEASE ALWAYS SPECIFY THE OVEN MODEL AND THE SERIAL NUMBER

ATTENTION: POUR COMMANDER DES PIÈCES, MERCI DE SPECIFIER TOUJOURS LE MODÈLE DU FOUR ET LE NUMÉRO DE SÉRIE
ACHTUNG: UM ERSATZTEILE ZU BESTELLEN, BITTE IMMER OFEN-MODELL UND SERIENNUMMER GEBEN.

ed. 0914

POS.	COD.	Pz.	DESCRIZIONE	DESCRIPTION	DESCRIPTION	BESCHREIBUNG	DESCRIPCIÓN
1	R58007000	2	PERNO ROTANTE LAVAGGIO MOB	ROTATING PIVOT	PIVOT TOURNANT	UMLAUFENDE STÜTZE	GOZNE ROTATORIO
2	R58007020	2	FLANGIA LAVAGGIO MOB	WASHING SYSTEM FLANGE	BRIDE BRAS DE LAVAGE	FLANSCH WASCHARMBEFESTIGUNG	PLATINA LAVADO
3	R70010080	2	GUARNIZIONE OR 14x2 Viton DIN 981	GASKETS	JOINT	RINGDICHTUNG	JUNTA
4	R62090663	2	RACCORDO OTTONE NICH.A L C/OGIVA 10X1/4"	ELBOW PIPE FITTING BRASS D.10x1/4"	RACCORDEMENT A COUDE LAITON D 10x1/4"	ELBOW PIPE FITTING BRASS D.10x1/4"	RACOR LATON DE GOMA D.10x1/4"
5	R65090260	2	MOTORID. LAV. METEOR (58U59DB4A1-00)	WASHING GEARED MOTORS	MOTO-REDUCTEURS DE LAVAGE	GETRIEBEMOTOREN	MOTORREDUCTORES LAVADO
6	R62090633	2	RACCORDO OTTONE CURVO 10/10 C/ OGIVA	ELBOW PIPE FITTING BRASS D.10	RACCORDEMENT A COUDE LAITON D 10	WINKELSTUTZEN AUS MESSING D,10	RACOR LATON DE GOMA D.10
7	R65110600	1	POMPA ELETTRON.A PIS.OSC.ET508LAB 2273	POMPE DETERGEANT	DETRGENT PUMP	REINIGERPUMPE	BOMBA DETERGENTE
8	R65110680	2	VALVOLA ANTIRITORNO J.G. 10SCV ELIMINATO DALLA SETTIMANA 27/2014	ANTI-BACK FLOW UNTIL WEEK 27/2014	ANTIRETOUR ÉLIMINÉ DU SEMAINE 27/2014	RÜCKFLUSSVERHINDERER BIS WOCHEN 27/2014	ANTIRETORNO ELIMINATO DEL SEMANA 27/2014
9	R62090468	1	RACCORDO INTERMEDIO A "T" D.10 PM0210E ELIMINATO DALLA SETTIMANA 27/2014	T MIDDLING PIPE FITTING D.10 UNTIL WEEK 27/2014	RACCORD INTERMEDIAIRE A "T" D.10 ÉLIMINÉ DU SEMAINE 27/2014	MITTELVERBINDUNGSSTÜCK D.10 "T"- FORMIG BIS WOCHEN 27/2014	RACOR INTERMEDIO TIPO "T" D.10 ELIMINATO DEL SEMANA 27/2014
10	R62090528	3	RACC.A GOMITO C/CODOLO 10X10 PM221010E ELIMINATO DALLA SETTIMANA 27/2014	ELBOW PIPE FITTING (WITH TANG) 10 X 10 UNTIL WEEK 27/2014	COURBE AVEC QUEUE 10x10 ÉLIMINÉ DU SEMAINE 27/2014	WINKELVERBINDUNGSSTÜCK 10 X 10 MIT SCHAFT BIS WOCHEN 27/2014	RACOR DE GOMA CON CODO 10x10 ELIMINATO DEL SEMANA 27/2014
11	R62090608	2	TERMINALE C/CODOLO 8x1/8" PM050811E	8X1/8 END SIDE PIPE FITTING (WITH TANG)	RACCORD AVEC QUEUE 8x1/8"	ENDVERBINDUNGSSTÜCK 8 X 1/8" MIT SCHAFT	RACOR TERMINAL CON CODO 8x1/8"
12	R62090618	1	RIDUZIONE INTERMEDIA 10-8 PM201008E ELIMINATO DALLA SETTIMANA 27/2014	REDUCTION PIPE FITTING UNTIL WEEK 27/2014	RACCORD DROIT REDUCTION ÉLIMINÉ DU SEMAINE 27/2014	GERADE ANSCHLUSS-VERKLEINERUNG BIS WOCHEN 27/2014	RACOR DERECHO REDUCCION BIS WOCHEN 27/2014
13	R62090678	1	RACC.A GOMITO C/CODOLO 8X8 PM220808E	ELBOW PIPE FITTING (WITH TANG) 8 X 8	COURBE AVEC QUEUE 8x8	WINKELVERBINDUNGSSTÜCK 8X8 MIT SCHAFT	RACOR DE GOMA CON CODO 8x8
14	R70010050	7	GUARNIZIONE OR 7,60 X 2,62 OR 3030 NB ELIMINATO DALLA SETTIMANA 27/2014	GASKETS UNTIL WEEK 27/2014	JOINT ÉLIMINÉ DU SEMAINE 27/2014	RINGDICHTUNG BIS WOCHEN 27/2014	JUNTA BIS WOCHEN 27/2014
15	R80150020	2m	TUBO DETERGENTE PE D.8mm x 6	PE D.8 MM X 6 DETERGENT FLEXIBLE PIPE	TUBE DETERGEANT D. 8x6	ROHRLEITUNG F. REINIGER PE D.8MMX6 (2MT)	TUBO DETERGENTE PE D.8mm X 6
16	R70070080	2m	TUBO CARICO ACQUA D.23mm x 13	PIPE	TUBE	LEITUNG	TUBO
17	R65110650	1	VALVOLA DI FONDO PER FILTRO GM.060.35	BOTTOM FILTER	FILTER POUR TUBE DETERGEANT	ANSAUGFILTER F. REINIGUNGSSCHAUCH	VÁLVULA DE FONDO TUBO DEL LIMPIADOR
18	R62020118	1	NIPPLES MASCHIO CONICO 1/4" PNID020200	STRAIGHT THREADED TERMINAL PIPE FITTING	RACCORD FILETE DROIT	ENDVERBINDUNGSSTÜCK GESCHNITTEN	RACOR TERMINAL DERECHO ROSCADO
19	R80120060	1m	TUBO SILIC. TRASP.SR60/TR 7/12.	PIPE	TUBE	LEITUNG	TUBO
20	R62090482	1	RACC.RAPIDO MASCHIO X LAVAG. PIPU40-C08M	RAPID MALE PIPE FITTING	RACCORD RAPIDE PARTIE MALE	SCHNELLVERBINDUNG MANNL	RACOR RAPIDO MACHO
21	R62090638	1	RACC.RAP.FEMM.X LAV.FIL.FEMM PVPV40-F1/4	RAPID FEMALE PIPE FITTING	RACCORD RAPIDE PARTIE FEMELLE	SCHNELLVERBINDUNG	RACOR RAPIDO HEMBRA
22	R62090538	1	RACC.DIR.F.1/4" TUBO6X8 A CALZ. PRCF220008	1/4" FEMALE STRAIGHT PIPE FITTING FOR D.6X8 PIPE	RACCORD DROIT PARTIE FEMELLE 1/4" TUBE 6x8	VERBINDUNGSSTÜCK 1/4" WEBL. FÜR ROHR D.6X8	RACOR DERECHO HEMBRA 1/4" PARA TUBO D.6x8
23	R65110280	1	E.V. 3 VIE 220V 50HZ X J.G.CON ATTACC	SOLENOID VALVE 220V 50HZ	ELECTROVANNE 220V 50HZ	MAGNETVENTIL 220V 50HZ	ELECTROVALVULA 220V 50HZ
24	R80150000	1m	TUBO PE D.10mm x 7 AZZURRO	PE D.10 MM X7 WATER FLEXIBLE PIPE	TUBE FLEXIBLE EAU D. 10x7	WASSERFLEXROHRLEITUNG PE D.10MMX7	TUBO FLEXIBLE AGUA PE D.10mm X 7
25	R62090688	1	RACC.TERMIN.DIR.FIL.CON.8X1/4 NC2500-P	8x1/4 STRAIGHT THREADED TERMINAL PIPE FITTING	RACCORD FILETE DROIT 8x1/4"	ENDVERBINDUNGSSTÜCK 8x1/4" GESCHNITTEN	RACOR TERMINAL DERECHO ROSCADO 8x1/4"
26	R58007030	2	TESTA LAVAGGIO MOB+ALBERO L=165	WASHING SYSTEM INNER ASSEMBLY	ENSEMBLE INTERIEUR DU LAVAGE	INNEN WASCHARMBEFESTIGUNG	KIT INTERNO LAVADO
27	R58005060	1	TAPPO TANICA GIALLO x LAVAGGIO	COVER	BOUCHON	ABDECKUNG	TAPON
28	R70045120	1	KIT GUARNIZIONI X LAVAGGIO MOB	GASKETS KIT	ENSEMBLE JOINTS	DICHTUNGSSATZ	KIT JUNTAS
29	R65090480	1	TEMPORIZZ. MULTIFUNZIONE MUR.1	MULTI FUNCTION TIMER	TEMPORISATEUR MULTIFONCTION	MULTI-FUNKTIONS TIMER	TEMPORIZADOR MULTIFUNCIÓN
30	R62090498	1	RACC.INTERMEDIO A GOMITO D.8 PM0308E DALLA SETTIMANA 28/2014 (07/07/2014)	ELBOW PIPE FITTING FROM WEEK 28/2014 (07/07/2014)	COURBE AVEC QUEUE DU SEMAINE 28/2014 (07/07/2014)	WINKELVERBINDUNGSSTÜCK VOM WOCHEN 28/2014 (07/07/2014)	RACOR DE GOMA DEL SEMANA 28/2014 (07/07/2014)
31	R62090888	1	COLLET.RES.ACET. 3VIE- 2D.10+1D.8 + 2ANTIRIT DALLA SETTIMANA 28/2014 (07/07/2014)	MANIFOLD FROM WEEK 28/2014 (07/07/2014)	COLLECTEUR DU SEMAINE 28/2014 (07/07/2014)	KRÜMMER VOM WOCHEN 28/2014 (07/07/2014)	COLECTOR DEL SEMANA 28/2014 (07/07/2014)

TAV. D

GEM T40 X

