

**ATTENZIONE:** PER ORDINARE I RICAMBI, SPECIFICARE SEMPRE IL MODELLO DI FORNO ED IL NUMERO DI MATRICOLA  
**ATTENTION:** WHEN ORDERING SPARE PARTS, PLEASE ALWAYS SPECIFY THE OVEN MODEL AND THE SERIAL NUMBER

**ATTENTION:** POUR COMMANDER DES PIÈCES, MERCI DE SPECIFIER TOUJOURS LE MODÈLE DU FOUR ET LE NUMÉRO DE SÉRIE  
**ACHTUNG:** UM ERSATZTEILE ZU BESTELLEN, BITTE IMMER OFEN-MODELL UND SERIENNUMMER GEBEN.

ed. 0914

POS.	COD.	Pz.	DESCRIZIONE	DESCRIPTION	DESCRIPTION	BESCHREIBUNG	DESCRIPCIÓN
1	R14217450	1	ASS.BOILER GEMT21 2011	STEAM GENERATOR ASSEMBLY	CHAUDIERE COMPLETE	DAMPFERZEUGER KOMPLETT	BOILER COMPLETO
2	R11205390	1	ASS.CERNIERA INFERIORE M-V/201-202	LOWER DOOR HINGE	CHARNIERE INFERIEURE PORTE	UNTERES SCHARNIER	BISAGRA INFERIOR
3	R10201710	1	ASS.FILTRO DI SCARICO D.86/44.5 M/210-12	DRAIN FILTER	FILTRE ENCEINTE	ABFLUSSFILTER	FILTRO DESAGUE
4	R62070023	3	BICONO PILOTA TUBO D.6 905.	BICONE D.6	BICONE D. 6	KEGEL D.6	BICONO D.6
5	R11426830	1	CERNIERA SUPER.PORTA SR.2013	UPPER DOOR HINGE	CHARNIERE SUPERIEURE PORTE	OBERES SCHARNIER	BISAGRA SUPERIOR
6	R58002540	1	CHIAVETTA X PERNO C/FERMO PORTM-V/120-22	DOOR PIVOT SUNK KEY	CLAVETTE POUR CHEVILLE PORTE	KEIL F. TUERSTIFT	LLAVE PARA PERNO PUERTA
7	R65140430	2	CONT.AUS. 1L+1R 3RH1921-1EA11 SIEMENS	AUX.CONTACT 1L+1R	CONTACT AUXILIAIRE 1L+1R	ZUSÄTZLICHER KONTAKT 1L+1R	CONTACTO AUXILIAR 1L+1R
8	R65260752	1	CONTATTO PER LUCI SR.2014+FORNI A PAVIM.	LAMPS CONTACT BLOCK	CONTACT ECLAIRAGE	LICHTKONTSCHALTER	CONTACTO PARA LUZ
9	R65240020	1	CONTRODADO PG 116/16/NY	CABLE GLAND LOCK NUT	CONTRE-ECROU POUR RONDELLE FIXATION	MUTTER	CONTRODADO PASACABLE
10	R58003850	2	CONTROFLANGIA GUARN. GRANDE	MOTOR GASKET BRASS COUNTER FLANGE	CONTRE- BRIDE JOINT MOTEUR	GEGENFLANSCH F. MOTORDICHTUNG	CONTRABRIDA JUNTA MOTOR
11	R62280038	1	CURVA C/MORSET.HTS-HTSW X TUBO D.50 D.50X	CURVE WITH TERMINAL	COURBE AVEC BORNIER	KURVE MIT KLEMM	CURVA CON REGLETERA
12	R58004030	2	DADO INOX 1"1/4X8 M/110-210-220 031010	NUT	ECROU	MUTTER	DADO
13	R58004050	1	DADO PER PERNO CERNIERA REG. M/106-220	NUT FOR UPPER DOOR HINGE	ECROU CHEVILLE CHARNIERE SUPERIEURE	MUTTER F. OBERES SCHARNIERSTIFT	TUERCA PARA PERNO BISAGRA SUPERIOR
14	R62060223	3	DADO PILOTA TUBO D.6 0903/1.	NUT D.6	ECROU D. 6	MUTTER D.6	DADO D.6
15	R65110200	1	E.V. 1 VIA 220V 50HZ X J.G.CON ATTACC	SOLENOID VALVE 1 VIA 220V 50HZ	ELECTROVANNE 1 VIA 220V 50HZ	MAGNETVENTIL 1 VIA 220V 50HZ	ELECTROVALVULA 1 VIA 220V 50HZ
16	R65110210	1	E.V. 2 VIE 220V 50HZ X J.G.CON ATTACC	SOLENOID VALVE 2 VIE 220V 50HZ	ELECTROVANNE 2 VIE 220V 50HZ	MAGNETVENTIL 2 VIE 220V 50HZ	ELECTROVALVULA 2 VIE 220V 50HZ
17	R61630011	2	FASCETTE ZINC.12-22/9	METAL CLAMPS 12-22/9	COLLIER DE SERRAGE 12-22/9	VERZINKTE SCHELLEN 12-22/9	ABRAZADERA 12-22/9
18	R61630031	4	FASCETTE ZINC.40-60/9	METAL CLAMPS 40-60/9	COLLIER DE SERRAGE 40-60/9	VERZINKTE SCHELLEN 40-60/9	ABRAZADERA 40-60/9
19	R65280490	1	FERRITE TOROIDALE FT36	FERRITE FT36	FERRITE FT36	FERRIT FT36	FERRITA FT36
20	R65280200	3	FILTRO Cx=0,47µF Cy=2X10nF	SUPPRESSOR	FILTRE	FILTER	FILTRO
21	R58003840	2	FLANGIA GUARN. GRANDE	MOTOR GASKET BRASS FLANGE	BRIDE JOINT MOTEUR	FLANSCH F. MOTORDICHTUNG	BRIDA JUNTA MOTOR
22	R62180182	1	FLEX H2O L=10-20CM M/F1" INOX DADO OT.	FLEXIBLE PIPE	TUBE FLEXIBLE	FLEXROHR	TUBO FLEXIBLE
23	R70010030	1	GUARNIZIONE OR 6,07 X 1,78 SILICONE	GASKETS OR 6,07 X 1,78	JOINT OR 6,07 X 1,78	RINGDICHTUNG OR 6,07 X 1,78	JUNTA OR 6,07 X 1,78
24	R70020050	2	GUARNIZIONE MARK IV MLA 2400.02.05	GASKETS	JOINT	RINGDICHTUNG	JUNTA
25	R70010210	1	GUARNIZIONE OR NBR 70 18,72x2,62 C.3075	GASKETS OR NBR 70 18,72x2,62	JOINT OR NBR 70 18,72x2,62	RINGDICHTUNG OR NBR 70 18,72x2,62	JUNTA OR NBR 70 18,72x2,62
26	R65070230	1	GUARNIZIONE PER TERM.SIC.CAMERM/106-110	GASKETS	JOINT	RINGDICHTUNG	JUNTA
27	R70010130	1	GUARNIZIONE SILICONE ROSSO 80x50,3x3	RED GASKETS	JOINT ROUGE	ROTEN RINGDICHTUNG	JUNTA ROJA
28	R70050150	1	GUARNIZIONE X TAPPO 2" PLAST. G40005	GASKETS	JOINT	RINGDICHTUNG	JUNTA
29	R70050140	1	GUARNIZIONE X TAPPO BOYLER PLAST. G40015	GASKETS	JOINT	RINGDICHTUNG	JUNTA
30	R70060080	1	MANICOTTO SILICONE D.13X18X80	SILICON SLEEVE	SILICONE SLEEVE	SILIKONHÜLLE	FUNDA DE SILICONA
31	R70060020	1	MANICOTTO SILICONE D.30X35X9 TAPPO SFIA	SILICON SLEEVE	SILICONE SLEEVE	SILIKONHÜLLE	FUNDA DE SILICONA
32	R70060040	2	MANICOTTO SILICONE D.50X50X3	SILICON SLEEVE	SILICONE SLEEVE	SILIKONHÜLLE	FUNDA DE SILICONA
33	R14425200	1	MANIGLIA CARRELLO KS/T21	HANDLE FOR TROLLY	POIGNÉE POUR CHARIOT PORTE POELES	HANDGRIFF-LAUFKATZE	MANIJA CARRO PORTABANDEJAS
34	R75300020	2	MASCHERINA VENTILATORE D.120 PER VENT.	FAN GUARD GRID D.120	GRILLE VENTILATEUR D.120	VENTILATORSCHUTZGITTER D.120	REJILLA VENTILADOR D.120
35	R75300070	2	MASCHERINA VENTILATORE D.350 N/S101 2014	FAN GUARD GRID D.350	GRILLE VENTILATEUR D.350	VENTILATORSCHUTZGITTER D.350	REJILLA VENTILADOR D.350
36	R65265100	1	MICRO PORTA MAGNETICO COMPLETO RIC.	DOOR SWITCH	MICRO PORTE	TUERSCHALTER	MICRO PUERTA
37	R61620091	16	MOLLA A TAZZA D.14/6,4X0,8 C70.	BELLEVILLE WASHER Ø 14/6.4	RESSORT A DISQUE Ø 14/6.4	TELLERFEDER Ø 14/6.4	MUELLE A DISCO Ø 14/6.4
38	R65220290	1	MORSETTIERA LX1(TIPO 3)NEW C/TERRA PASS.	TERMINAL BOARD	BORNIER	KLEMMLEISTE	REGLETERA
39	R65040530	2	MOTORE KW 055 F3 4P 3039 200-440V I	MOTOR	MOTEUR	MOTOR	MOTOR
40	R58002550	1	PATTINO FERMO PORTA M-V/120-220	DOOR RETAINER GUIDE SHOE	PATIN ARRET PORTE	GLEITSTUECK F. TUERARRETIERUNG	PATILLA CIERRE PUERTA
41	R58003140	3	PERNO AGGANCIO DEFLETTORE	FAN GUARD PANEL PIN	PIVOT DEFLECTEUR	BOLZEN FÜR LUFTLEITBLECH	PERNO CIERRE DEFLECTOR
42	R58003110	3	PERNO FISSAGGIO DEFLETTORE	FAN GUARD PANEL PIN	PIVOT DEFLECTEUR	BOLZEN FÜR LUFTLEITBLECH	PERNO CIERRE DEFLECTOR
43	R58002150	1	PERNO SUP.CERNIERA REG. M/106-220	UPPER HINGE PIN	CHEVILLE CHARNIERE SUPERIEURE	OBERES SCHARNIERSTIFT	PERNO SUPERIOR BISAGRA
44	R65210020	6	PORTAFUSIBILE BARRA DIN 5x20	FUSE CARRIER	PORTE-FUSIBLE	SICHERUNGSHALTER	PORTAFUSIBILE
45	R65240010	1	PRESSACAVO PG 107 Z/16	FAIRLEAD	PRESSE CABLE	ZUGENTLASTUNG	PRENSACABLES

**TAV. A**

**GEM T21 S**

**ATTENZIONE:** PER ORDINARE I RICAMBI, SPECIFICARE SEMPRE IL MODELLO DI FORNO ED IL NUMERO DI MATRICOLA  
**ATTENTION:** WHEN ORDERING SPARE PARTS, PLEASE ALWAYS SPECIFY THE OVEN MODEL AND THE SERIAL NUMBER

**ATTENTION:** POUR COMMANDER DES PIÈCES, MERCI DE SPECIFIER TOUJOURS LE MODÈLE DU FOUR ET LE NUMÉRO DE SÉRIE  
**ACHTUNG:** UM ERSATZTEILE ZU BESTELLEN, BITTE IMMER OFEN-MODELL UND SERIENNUMMER GEBEN.

ed. 0914

POS.	COD.	Pz.	DESCRIZIONE	DESCRIPTION	DESCRIPTION	BESCHREIBUNG	DESCRIPCIÓN
46	R58002560	1	PRESSORE FERMO PORTA M-V/120- 220	SCREW FOR LOWER DOOR HINGE	VIS POUR CHARNIERE INFERIEURE	DRUCKSCHRAUBE F. UNTERERS TUERSCHARNIER	TORNILLO PARA BISAGRA INFERIOR
47	R65090220	1	PROGRAMMAT. 1 CAMME V220/50HZ 1 CIRC.	DAMPER SYSTEM	SORTIE EVAPORATION MOUFLE	DAMPFABLASS-STELLMOTOR	MOTOR RESPIRADERO COMPLETO
48	R62090478	1	RACC. INTERMEDIO A GOMITO D.10 PM0310E	ELBOW PIPE FITTING	COURBE AVEC QUEUE	STUCK MIT SCHAFT	RACOR CON CODO
49	R62090458	1	RACC. INTERMEDIO DIRITTO D.10 PM0410E	PIPE FITTING	COURBE	STUCK	RACOR
50	R65110510	1	REGOL. PORTATA ROSSO ALPHATECH. 1.5LT/H	1.5 LT/H WATER FLOW REDUCER	REGULATUER DE DEBIT 1.5 LT.	DURCHFLOSSMONDERER 1.5 L/STD.	REGULADOR DE CAUDAL 1.5 LT.
51	R65020421	2	RESISTENZA 15000W230V BOILER ME/220 TRI	CHAMBER HEATING ELEMENT 15000W230V	RESISTANCE MOUFLE 15000W230V	GARRAUM HEIZKOERPER 15000W230V	RESISTENCIA CAMARA 15000W230V
52	R65011310	2	RESISTENZA CIRC.15000W 230V CAMME-VE/110	CHAMBER HEATING ELEMENT 15000W	RESISTANCE MOUFLE 15000W	GARRAUM HEIZKOERPER 15000W	RESISTENCIA CAMARA 15000W
53	R58004010	2	ROND.FISS.VENTOLA D 30/12.5	FAN WASHER Ø 30/12.5	RONDELLE TURBINE Ø 30/12.5	UNTERLEGSSCHEIBE Ø 30/12.5	ARANDELA FIJACION TURBINA Ø 30/12.5
54	R58002570	1	RONDELLA 30/15X3 M-V/120-220	WASHER	RONDELLE	UNTERLEGSSCHEIBE	ARANDELA
55	R69090360	2	RUOTA GIR.DOPPIA C/FR. D.100 (5945UAP100)	WHEEL	ROUE	RAD	RUEDA
56	R69090350	2	RUOTA GIR.DOPPIA D.100 (5940UAP100)	WHEEL	ROUE	RAD	RUEDA
57	R69180120	1	SCATOLA COND.SCARICO G/MV T06-T10-T21	QUENCHING-DRAIN COLLECTOR	BOITE DE CONDENSATION DECHARGE	KONDENSATION-ABFLUSS SCHACHTEL	CAJON CONDENSACION-DESAGÜE
58	R65320220	3	SONDA "K" 6X80 1,5ML. TESTA RASTREM.20mm	PROBE "K" 6X80 1,5ML.	SONDE "K" 6X80 1,5ML.	FUEHLER "K" 6X80 1,5ML.	SONDA "K" 6X80 1,5ML.
59	R65320010	2	SONDA LIVELLO TL 10/B	LEVEL PROBE	SONDE DE NIVEAU	WASSERSSTANDSFUEHLER	SONDA NIVEL
60	R58005700	1	TAPPO ESAGONALE 1" F ART. 761	COVER	BOUCHON	ABDECKUNG	TAPON
61	R69150110	1	TAPPO FEMMINA G 1"1/4 PP+25%FV NERO	COVER	BOUCHON	ABDECKUNG	TAPON
62	R69150100	1	TAPPO FEMMINA G 2" PP+25%FV NERO	COVER	BOUCHON	ABDECKUNG	TAPON
63	R65140380	2	TELERUTTORE 3RT1016-1AP02	CONTACTOR	CONTACTEUR	SCHUETZ	CONTACTOR
64	R65140400	8	TELERUTTORE 3RT1025-1AL20 SIEMENS	CONTACTOR	CONTACTEUR	SCHUETZ	CONTACTOR
65	R65160620	2	TERM.MOT.3RU1116-1BB0 1,4-2,0 SIEMENS	THERMIC PROTECTION 3RU1116-1BB0 1,4-2,0	PROTECTION THERMIQUE 3RU1116-1BB0 1,4-2,0	MOTORSCHUTZSCHALTER 3RU1116-1BB0 1,4-2,0	TERMICO 3RU1116-1BB0 1,4-2,0
66	R62090868	1	TERMINALE CIECO D.10 PSE4610W	PIPE FITTING	COURBE	STUCK	RACOR
67	R65070350	1	TERMOSTATO SICUR. 360°C -25K 55.32572.8	THERMOSTAT	THERMOSTAT	THERMOSTAT	TERMOSTATO
68	R65070081	1	TERMOSTATO SICUR. BOILER M/1065532522852	THERMOSTAT	THERMOSTAT	THERMOSTAT	TERMOSTATO
69	R65180420	1	TRASF.RE 20VA 0-220-240/12V MOD.163.16	TRANSFORMER 20VA	TRANSFORMATEUR 20VA	TRANSFORMATOR 20VA	TRANSFORMADOR 20VA
70	R65180430	1	TRASF.RE 40VA 0-220-240/12V MOD.163.82	TRANSFORMER 40VA	TRANSFORMATEUR 40VA	TRANSFORMATOR 40VA	TRANSFORMADOR 40VA
71	R80150000	4	TUBO PE 10mm x7 AZZURRO PM950612E	BLUE PIPE	TUBE	LEITUNG	TUBO
72	R58006160	2	UGELLO COND.D.0,8 CODOLO CIL.10	NOZZLE	BEC	DÜSE	BOQUILLA
73	R65110570	1	VALVOLA A SFERA MOTORIZZATA 2VIE 230V 1"	STEAM GENERATOR DRAIN MOTORIZED VALVE	DRAINAGE CHAUDIERE	BOILERABLAUFVENTIL	VALVULA DE BOLA MOTORIZADA
74	R65060050	4	VENTILATORE COMPATTO D.120 4715MS 23T	COMPONENTS VENTILATION MOTOR D.120	MOTEUR DE REFRROIDISSMENT D.120	ABKULUNGS MOTOR D.120	MOTOR DE ENFRIAMIENTO D.120
75	R75400440	2	VENTOLA D.350X114/12 50HZ P.D.	FAN	TURBINE	LUEFTERRAD	PALA VENTILADOR
76	R58004000	2	VITE FISS.VENTOLA M/12X1.5 SX .	FAN SCREW M12x1.5 SX	VIS DE BLOCAGE TURBINE M12x1.5 SX	VENTILATORSCHRAUBE M12x1.5 SX	TORNILLO FIJACION TURBINA M12x1.5 SX
77	R61020562	2	VITE TE A2 M 6X55 UNI 5737.	MOTOR SCREW TE A2 M6x55	VIS DE BLOCAGE MOTEUR TE A2 M6x55	MOTORSCHRAUBE TE A2 M6x55	TORNILLO MOTOR TE A2 M6x55
78	R62200028	1	LANCIA DI LAVAGGIO SENZA TUBO	SHOWER HANDLE	POIGNEE DOUCHETTE	GRIFF F. HANDBRAUSE	MANGO DUCHA
79	R62200058	1	GOMMA 1/2"X1/2"X2.5M	FLEXIBLE PIPE SHOWER	TUBE FLEXIBLE DOUCHETTE	SCHEAUCH FUER HANDBRAUSE	TUBO FLEXIBLE DUCHA
80	R70030040	2	GUARNIZIONE D.16X24 3/4 GOMMA	GASKET D.16X24 3/4	JOINT D.16X24 3/4	DICHTUNG D.16X24 3/4	JUNTA D.16X24 3/4
81	R70030030	1	GUARNIZIONE D.11X19 1/2" GOMMA	GASKET D. 11X19 1/2"	JOINT D. 11X19 1/2"	DICHTUNG D. 11X19 1/2"	JUNTA D. 11X19 1/2"
82	R69180300	1	SUPPORTO IN PLASTICA PER DOCC. ESTERNO	HOLDER	SUPPORT	HALTERUNG	SOPORTE
83	R10100140	1	TAPPO SFIATO COMPLETO M/106-. -220 FINO ALLA SETTIMANA 26/2014	COVER UNTIL WEEK 26/2014	BOUCHON ÉLIMINÉ DU SEMAINE 26/2014	ABDECKUNG BIS WOCHE 26/2014	TAPON ELIMINATO DEL SEMANA 26/2014
83	R58006690	1	TAPPO SFIATO COMPLETO SERIE 2014 DALLA SETTIMANA 27/2014	COVER SINCE WEEK 27/2014	BOUCHON DU SEMAINE 27/2014	ABDECKUNG VOM WOCHE 27/2014	TAPON DEL SEMANA 27/2014
84	R62090918	2	RACC.INT.A GOMITO D.10 SPEEDFIT PEM0310W DALLA SETTIMANA 28/2014 (7/7/2014)	WHITE ELBOW PIPE FITTING D.10 SINCE WEEK 28/2014 (7/7/2014)	COURBE AVEC QUEUE DU SEMAINE 28/2014 (7/7/2014)	STUCK MIT SCHAFT VOM WOCHE 28/2014 (7/7/2014)	RACOR CON CODO DEL SEMANA 28/2014 (7/7/2014)
85	R62090928	1	RACC.GOMITO C/COD.SPEEDFIT 10 PEM221010W DALLA SETTIMANA 28/2014 (7/7/2014)	WHITE ELBOW PIPE FITTING D.10 SINCE WEEK 28/2014 (7/7/2014)	COURBE AVEC QUEUE DU SEMAINE 28/2014 (7/7/2014)	STUCK MIT SCHAFT VOM WOCHE 28/2014 (7/7/2014)	RACOR CON CODO DEL SEMANA 28/2014 (7/7/2014)
86	R80150060	2 m	TUBO PEX-B 10MM ROTOLO 100MT 10BPEX-100C DALLA SETTIMANA 28/2014 (7/7/2014)	PIPE SINCE WEEK 28/2014 (7/7/2014)	TUBE DU SEMAINE 28/2014 (7/7/2014)	LEITUNG VOM WOCHE 28/2014 (7/7/2014)	TUBO DEL SEMANA 28/2014 (7/7/2014)
87	R65160550	2	SUPP. TERMICO RU1116-0JBO 0,7-1 SIEMENS	THERMAL SUPPORT	SUPPORT THERMIQUE	THERMISCHE UNTERSTÜTZUNG	APOYO TÉRMICO

TAV. A

GEM T21 S

**ATTENZIONE:** PER TENSIONI SPECIALI, SPECIFICARE SEMPRE IL MODELLO DI FORNO ED IL NUMERO DI MATRICOLA  
**ATTENTION:** FOR SPECIAL VOLTAGES, PLEASE ALWAYS SPECIFY THE OVEN MODEL AND THE SERIAL NUMBER

**ATTENTION:** POUR TENSIONS SPÉCIALES, MERCI DE SPÉCIFIER TOUJOURS LE MODÈLE DU FOUR ET LE NUMÉRO DE SÉRIE  
**ACHTUNG:** BEI SONDRSPANNUNGEN, BITTE IMMER OFEN-MODELL UND SERIENNUMMER GEBEN.

ed. 0914

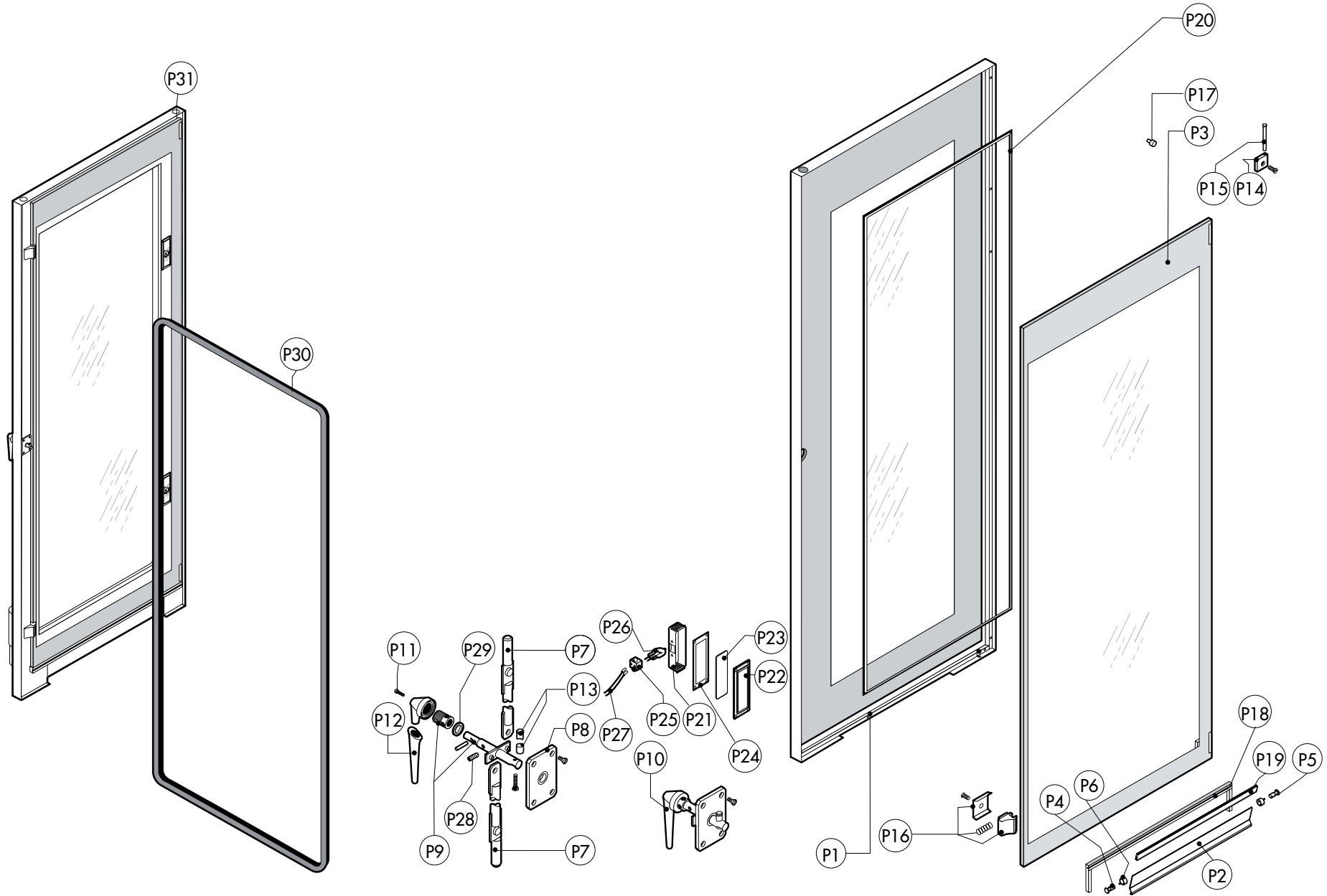



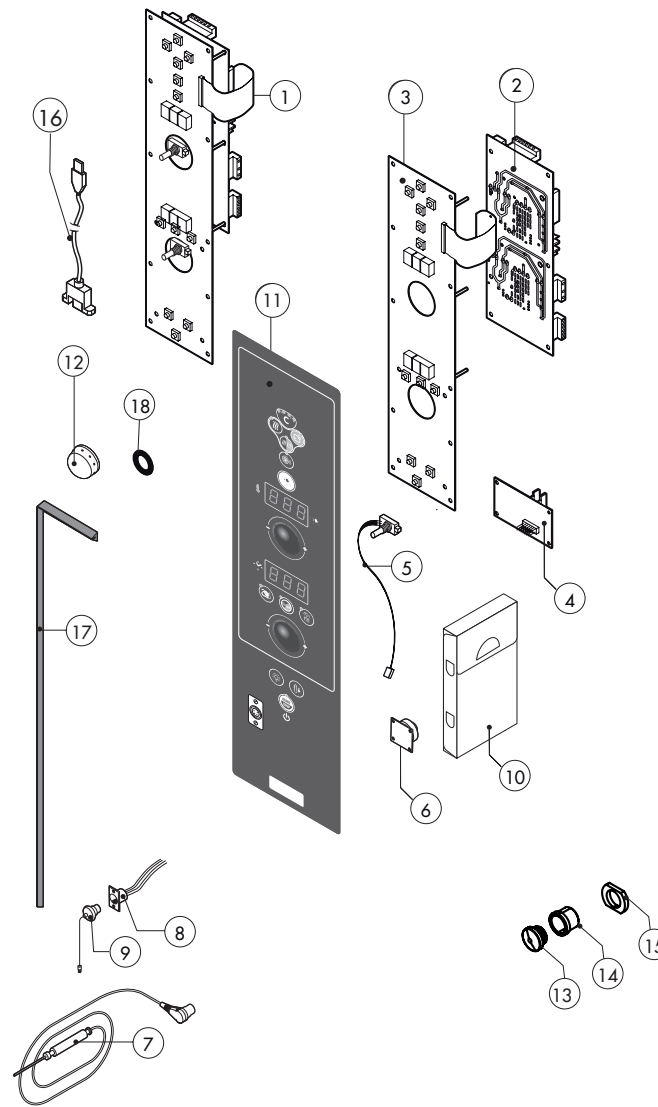





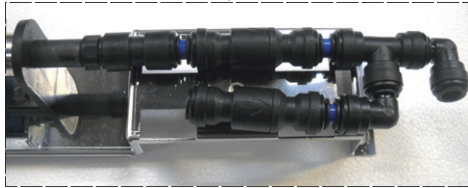
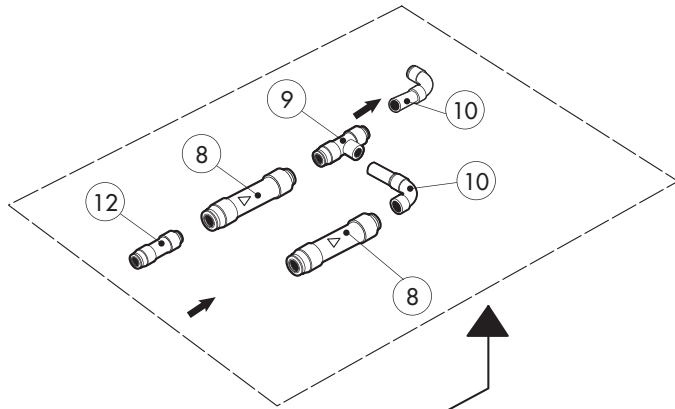

fino alla settimana 27/2014 - until week 27/2014  
 élimine du semaine 27/2014  
 bis woche 27/2014 - eliminato del semana 27/2014

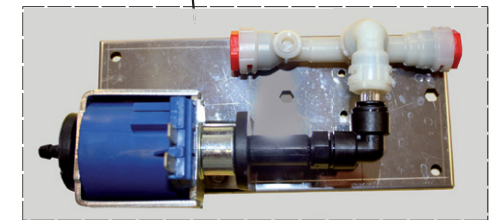
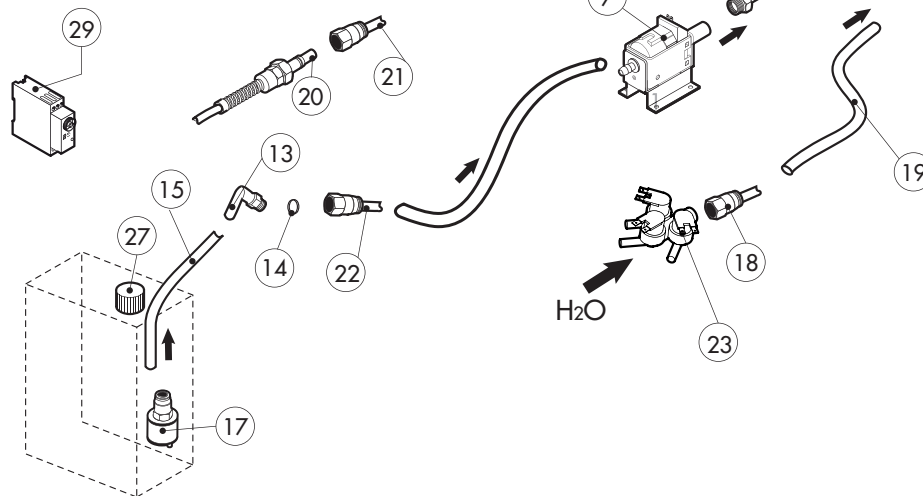
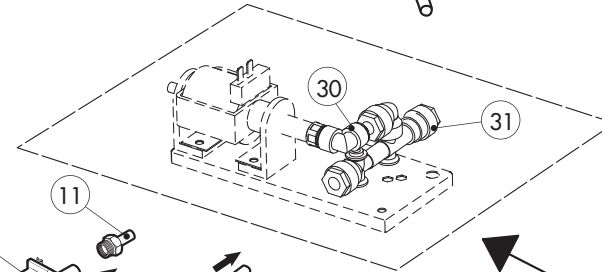
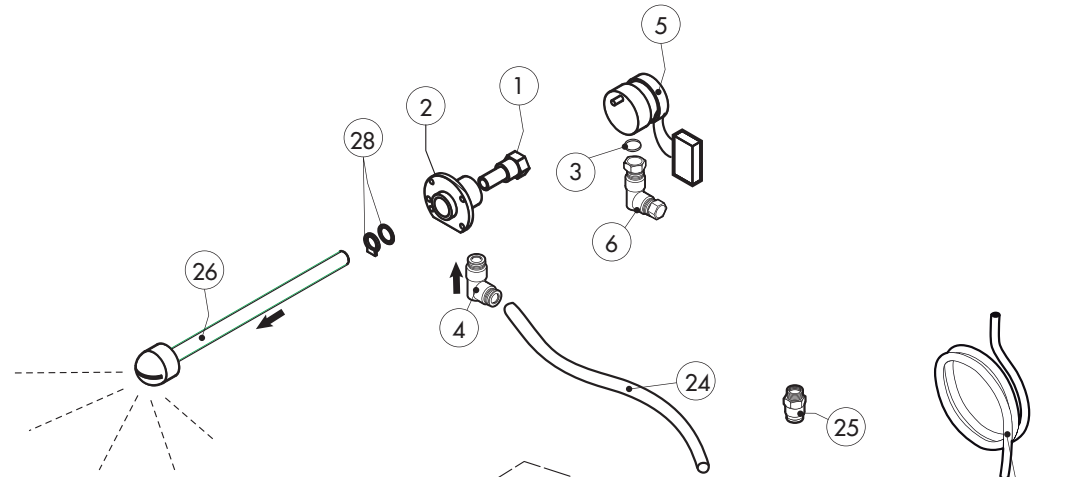

dalla settimana 28/2014 - from week 28/2014  
 du semaine 28/2014 - vom woche 28/2014  
 del semana 28/2014



POS.	COD.	Pz.	DESCRIZIONE	DESCRIPTION	DESCRIPTION	BESCHREIBUNG	DESCRIPCIÓN
1	R58007000	2	PERNO ROTANTE LAVAGGIO MOB	ROTATING PIVOT	PIVOT TOURNANT	UMLAUFENDE STÜTZE	GOZNE ROTATORIO
2	R58007020	2	FLANGIA LAVAGGIO MOB	WASHING SYSTEM FLANGE	BRIDE BRAS DE LAVAGE	FLANSCH WASCHARMBEFESTIGUNG	PLATINA LAVADO
3	R70010080	2	GUARNIZIONE OR 14x2 Viton DIN 981	GASKETS	JOINT	RINGDICHTUNG	JUNTA
4	R62090663	2	RACCORDO OTTONE NICH.A L C/OGIVA 10X1/4"	ELBOW PIPE FITTING BRASS D.10x1/4"	RACCORDEMENT A COUDE LAITON D 10x1/4"	ELBOW PIPE FITTING BRASS D.10x1/4"	RACOR LATON DE GOMA D.10x1/4"
5	R65090260	2	MOTORID. LAV. METEOR (58U59DB4A1-00)	WASHING GEARED MOTORS	MOTO-REDUCTEURS DE LAVAGE	GETRIEBEMOTOREN	MOTORREDUCTORES LAVADO
6	R62090633	2	RACCORDO OTTONE CURVO 10/10 C/OGIVA	ELBOW PIPE FITTING BRASS D.10	RACCORDEMENT A COUDE LAITON D 10	WINKELSTUTZEN AUS MESSING D.10	RACOR LATON DE GOMA D.10
7	R65110600	1	POMPA ELETTRONICA PIS.OSC.ET508LAB 2273	POMPE DETERGEANT	DETERGENT PUMP	REINIGERPUMPE	BOMBA DETERGENTE
8	R65110680	2	VALVOLA ANTIRITORNO J.G. 10SCV ELIMINATO DALLA SETTIMANA 27/2014	ANTI-BACK FLOW UNTIL WEEK 27/2014	ANTI-RETOUR ÉLIMINÉ DU SEMAINE 27/2014	RÜCKFLUSSVERHINDERER BIS WOCHEN 27/2014	ANTIRETORNO ELIMINATO DEL SEMANA 27/2014
9	R62090468	1	RACCORDO INTERMEDIO A "T" D.10 PM0210E ELIMINATO DALLA SETTIMANA 27/2014	T MIDDLING PIPE FITTING D.10 UNTIL WEEK 27/2014	RACCORD INTERMEDIAIRE A "T" D.10 ÉLIMINÉ DU SEMAINE 27/2014	MITTELVERBINDUNGSSTÜCK D.10 "T"- FORMIG BIS WOCHEN 27/2014	RACOR INTERMEDIO TIPO "T" D.10 ELIMINATO DEL SEMANA 27/2014
10	R62090528	3	RACC.A GOMITO C/CODOLO 10X10 PM221010E ELIMINATO DALLA SETTIMANA 27/2014	ELBOW PIPE FITTING (WITH TANG) 10 X 10 UNTIL WEEK 27/2014	COURBE AVEC QUEUE 10x10 ÉLIMINÉ DU SEMAINE 27/2014	WINKELVERBINDUNGSSTÜCK 10 X 10 MIT SCHAFT BIS WOCHEN 27/2014	RACOR DE GOMA CON CODO 10x10 ELIMINATO DEL SEMANA 27/2014
11	R62090608	2	TERMINALE C/CODOLO 8x1/8" PM050811E	8X1/8 END SIDE PIPE FITTING (WITH TANG)	RACCORD AVEC QUEUE 8x1/8"	ENDVERBINDUNGSSTÜCK 8 X 1/8" MIT SCHAFT	RACOR TERMINAL CON CODO 8x1/8"
12	R62090618	1	RIDUZIONE INTERMEDIA 10-8 PM201008E ELIMINATO DALLA SETTIMANA 27/2014	REDUCTION PIPE FITTING UNTIL WEEK 27/2014	RACCORD DROIT REDUCTION ÉLIMINÉ DU SEMAINE 27/2014	GERADE ANSCHLUSS-VERKLEINERUNG BIS WOCHEN 27/2014	RACOR DERECHO REDUCCION BIS WOCHEN 27/2014
13	R62090678	1	RACC.A GOMITO C/CODOLO 8X8 PM220808E	ELBOW PIPE FITTING (WITH TANG) 8 X 8	COURBE AVEC QUEUE 8x8	WINKELVERBINDUNGSSTÜCK 8X8 MIT SCHAFT	RACOR DE GOMA CON CODO 8x8
14	R70010050	7	GUARNIZIONE OR 7,60 X 2,62 OR 3030 NB ELIMINATO DALLA SETTIMANA 27/2014	GASKETS UNTIL WEEK 27/2014	JOINT ÉLIMINÉ DU SEMAINE 27/2014	RINGDICHTUNG BIS WOCHEN 27/2014	JUNTA BIS WOCHEN 27/2014
15	R80150020	2m	TUBO DETERGENTE PE D.8mm x 6	PE D.8mm x6 DETERGENT FLEXIBLE PIPE	TUBE DETERGEANT D. 8x6	ROHRLEITUNG F. REINIGER PE D.8mm x6 (2MT)	TUBO DETERGENTE PE D.8mm X 6
16	R70070080	2m	TUBO CARICO ACQUA D.23mm x 13	PIPE	TUBE	LEITUNG	TUBO
17	R65110650	1	VALVOLA DI FONDO PER FILTRO GM.060.35	BOTTOM FILTER	FILTER POUR TUBE DETERGEANT	ANSAUGFILTER F. REINIGUNGSSCHAUCH	VÁLVULA DE FONDO TUBO DEL LIMPIADOR
18	R62020118	1	NIPPLES MASCHIO CONICO 1/4" PNID020200	STRAIGHT THREADED TERMINAL PIPE FITTING	RACCORD FILETE DROIT	ENDVERBINDUNGSSTÜCK GESCHNITTEN	RACOR TERMINAL DERECHO ROSCADO
19	R80120060	1m	TUBO SILIC. TRASP.SR60/TR 7/12.	PIPE	TUBE	LEITUNG	TUBO
20	R62090482	1	RACC.RAPIDO MASCHIO X LAVAG. PIPU40-C08M	RAPID MALE PIPE FITTING	RACCORD RAPIDE PARTIE MALE	SCHNELLVERBINDUNG MANNL	RACOR RAPIDO MACHO
21	R62090638	1	RACC.RAP.FEMM.X LAV.FIL.FEMM PVPJ40-F1/4	RAPID FEMALE PIPE FITTING	RACCORD RAPIDE PARTIE FEMELLE	SCHNELLVERBINDUNG	RACOR RAPIDO HEMBRA
22	R62090538	1	RACC.DIR.F.1/4"TUBO6X8 A CALZ. PRCF220008	1/4" FEMALE STRAIGHT PIPE FITTING FOR D.6X8 PIPE	RACCORD DROIT PARTIE FEMELLE 1/4" TUBE 6x8	VERBINDUNGSSTÜCK 1/4" WEIBL. FÜR ROHR D.6X8	RACOR DERECHO HEMBRA 1/4" PARA TUBO D.6x8
23	R65110280	1	E.V. 3 VIE 220V 50HZ X J.G.CON ATTACC	SOLENOID VALVE 220V 50HZ	ELECTROVANNE 220V 50HZ	MAGNETVENTIL 220V 50HZ	ELECTROVALVULA 220V 50HZ
24	R80150000	1m	TUBO PE D.10mm x 7 AZZURRO	PE D.10mm x7 WATER FLEXIBLE PIPE	TUBE FLEXIBLE EAU D. 10x7	WASSERFLEXROHRLEITUNG PE D.10mm x7	TUBO FLEXIBLE AGUA PE D.10mm X 7
25	R62090688	1	RACC.TERMIN.DIR.FIL.CON.8X1/4 NC2500-P	8x1/4 STRAIGHT THREADED TERMINAL PIPE FITTING	RACCORD FILETE DROIT 8x1/4"	ENDVERBINDUNGSSTÜCK 8x1/4" GESCHNITTEN	RACOR TERMINAL DERECHO ROSCADO 8x1/4"
26	R58007030	2	TESTA LAVAGGIO MOB+ALBERO L=165	WASHING SYSTEM INNER ASSEMBLY	ENSEMBLE INTERIEUR DU LAVAGE	INNEN WASCHARMBEFESTIGUNG	KIT INTERNO LAVADO
27	R58005060	1	TAPPO TANICA GIALLO x LAVAGGIO	COVER	BOUCHON	ABDECKUNG	TAPON
28	R70045120	1	KIT GUARNIZIONI X LAVAGGIO MOB	GASKETS KIT	ENSEMBLE JOINTS	DICHTUNGSSATZ	KIT JUNTAS
29	R65090480	1	TEMPORIZZ. MULTIFUNZIONE MUR.1	MULTI FUNCTION TIMER	TEMPORISATEUR MULTIFONCTION	MULTI-FUNKTIONS TIMER	TEMPORIZADOR MULTIFUNCIÓN
30	R62090498	1	RACC.INTERMEDIO A GOMITO D.8 PM0308E DALLA SETTIMANA 28/2014 (07/07/2014)	ELBOW PIPE FITTING SINCE WEEK 28/2014 (07/07/2014)	COURBE AVEC QUEUE DU SEMAINE 28/2014 (07/07/2014)	WINKELVERBINDUNGSSTÜCK VOM WOCHEN 28/2014 (07/07/2014)	RACOR DE GOMA DEL SEMANA 28/2014 (07/07/2014)
31	R62090888	1	COLLET.RES.ACET. 3VIE- 2D.10+1D.8 + 2ANTI-RIT DALLA SETTIMANA 28/2014 (07/07/2014)	MANIFOLD SINCE WEEK 28/2014 (07/07/2014)	COLLECTEUR DU SEMAINE 28/2014 (07/07/2014)	KRÜMMER VOM WOCHEN 28/2014 (07/07/2014)	COLECTOR DEL SEMANA 28/2014 (07/07/2014)

