

POS.	CODE	PIECES	DESCRIPTION
1	R14102020	1	DOOR ASSEMBLY UNTIL CRXXXXXX0
	R14102030	1	DOOR ASSEMBLY FROM CRXXXXXX1
2	R14211810	1	CONTROL PANEL UNTIL CRXXXXXX0
	R11203310	1	CONTROL PANEL FROM CRXXXXXX1
3	R11201970	1	SPRITZER EXTENSION
4	R11200380	1	SPRITZER UNION
5	R14102150	1	COOKING CABINET ASSEMBLY
6	R14211640	1	FAN GUARD PANEL ASSEMBLY
7	R14422100	1	RIGHT SIDE PANEL UNTIL CRXXXXXX0
	R14214750	1	RIGHT SIDE PANEL FROM CRXXXXXX1
8	R14422110	1	LEFT SIDE PANEL UNTIL CRXXXXXX0
	R14214760	1	LEFT SIDE PANEL FROM CRXXXXXX1
9	R14211760	1	REAR PANEL UNTIL CRXXXXXX0
	R14214770	1	REAR PANEL FROM CRXXXXXX1
10	R14211270	1	COVER PANEL UNTIL CRXXXXXX0
	R14214610	1	COVER PANEL FROM CRXXXXXX1
11	R58003100	2	FAN GUARD FASTENING SCREW
12	R70044220	1	FRONT GASKET
13	R75300020	1	FAN GUARD GRID Ø 120

POS.	CODE	PIECES	DESCRIPTION
14	R75300090	1	FAN GUARD GRID Ø 350
15	R14211680	1	REMOVABLE RACK DX
16	R14211690	1	REMOVABLE RACK SX

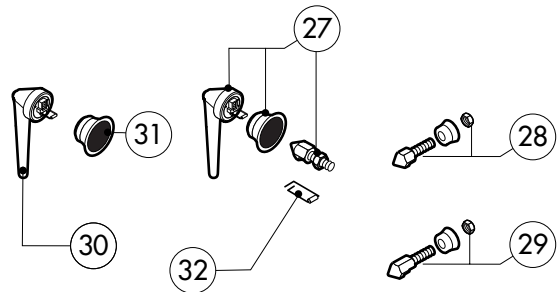
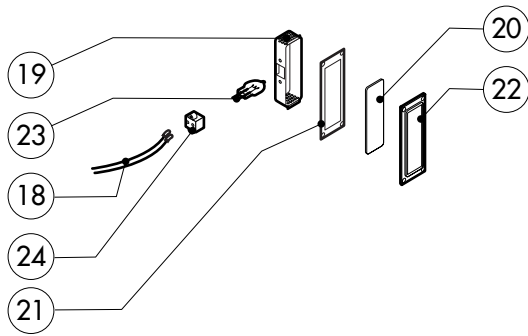
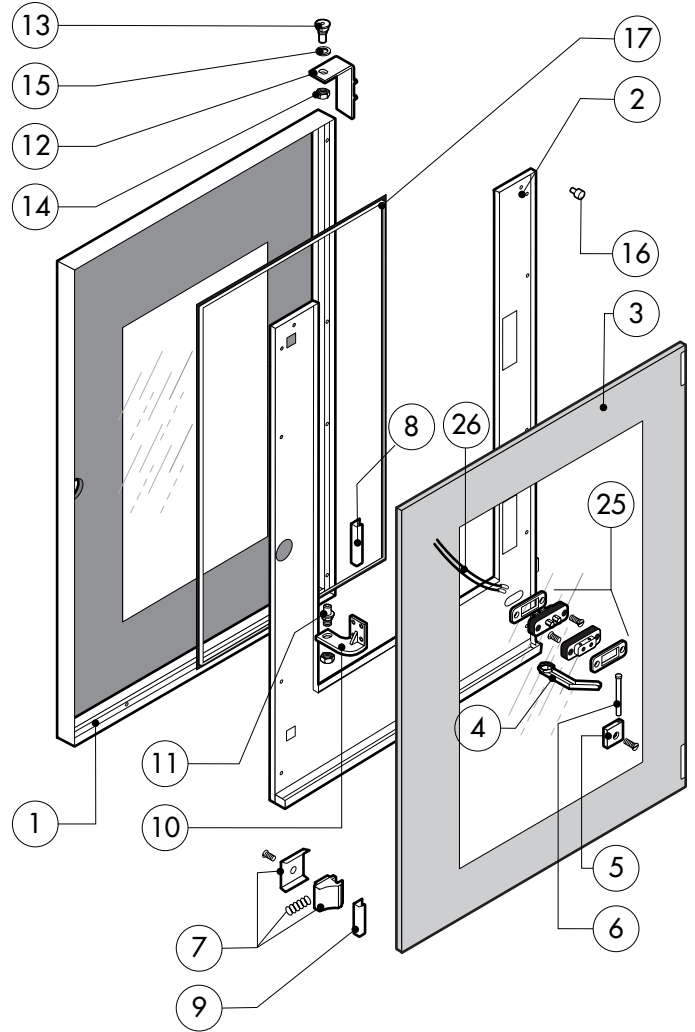
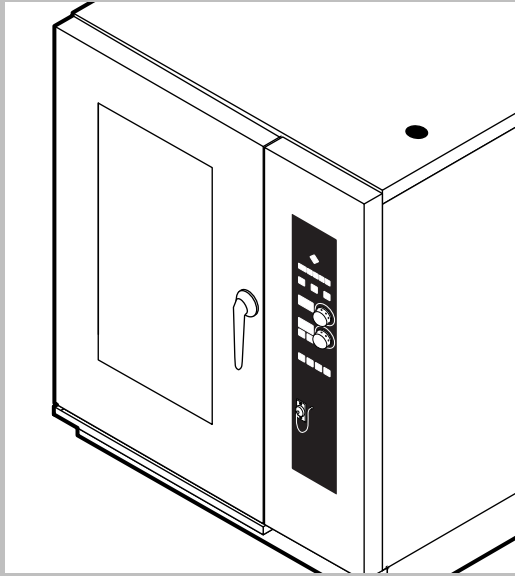

POS.	CODE	PIECES	DESCRIPTION
1	R14211150	1	DOOR UNTIL CRXXXXXX0
	R14214700	1	DOOR FROM CRXXXXXX1
2	R14211200	1	INNER DOOR PANEL UNTIL CRXXXXXX0
	R14214710	1	INNER DOOR PANEL FROM CRXXXXXX1
3	R71201660	1	INNER DOOR GLASS
4	R69180000	1	DOOR DRIP TRAY DRAINAGE FROM CRXXXXXX1
5	R58001760	2	INNER GLASS SOLID HINGE
6	R58001770	2	INNER GLASS HINGE PIN
7	R58001780	2	INNER GLASS CATCH KIT
8	R11401340	1	TOP "C" PROFILE
9	R11401360	1	LOWER "C" PROFILE
10	R11207250	1	LOWER DOOR HINGE UNTIL CRXXXXXX0
	R11207240	1	LOWER DOOR HINGE FROM CRXXXXXX1
11	R58002520	1	LOWER HINGE PIN UNTIL CRXXXXXX0
	R58002670	1	LOWER HINGE PIN FROM CRXXXXXX1
12	R11200560	1	UPPER DOOR HINGE
13	R58002150	1	HINGE PIN
14	R58004050	2	NUT FOR UPPER DOOR HINGE
15	R10401710	1	WASHER FOR UPPER DOOR HINGE

POS.	CODE	PIECES	DESCRIPTION
16	R70050100	6	GLASS SILICON SPACERS
17	R70040640	1	GLASS GASKET
18	R66110320	1	DOOR LAMPS CABLE SET
19	R11401440	2	LAMP COVER
20	R71500150	2	GLASS LAMP
21	R70044200	2	LAMP GASKET
22	R11401450	2	GLASS HOLDER LAMP FLANGE
23	R65270020	2	LIGHT 20W 12V G4
24	R65270450	2	LIGHT SOCKET
25	R65260750	1	LAMPS CONTACT BLOCK
26	R66110300	1	LAMPS CONTACT CABLE SET
27	R11100300	1	DOOR HANDLE ASSEMBLY
28	R69010260	1	DOOR LATCH 1 STEP
29	R69010270	1	DOOR LATCH 2 STEP
30	R69010250	1	DOOR CATCH KIT
31	R69010630	1	INNER DOOR CATCH PLASTIC COVER
32	R61620132	1	PRONG FLANGE

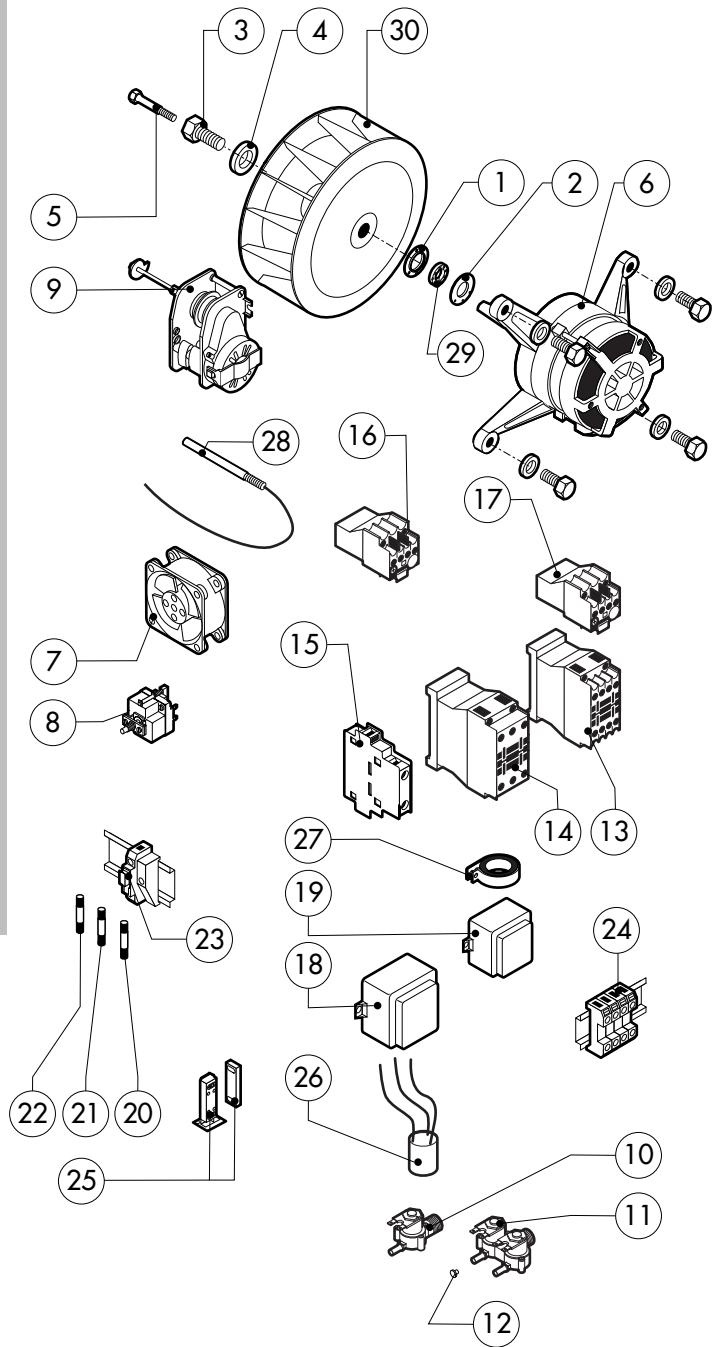
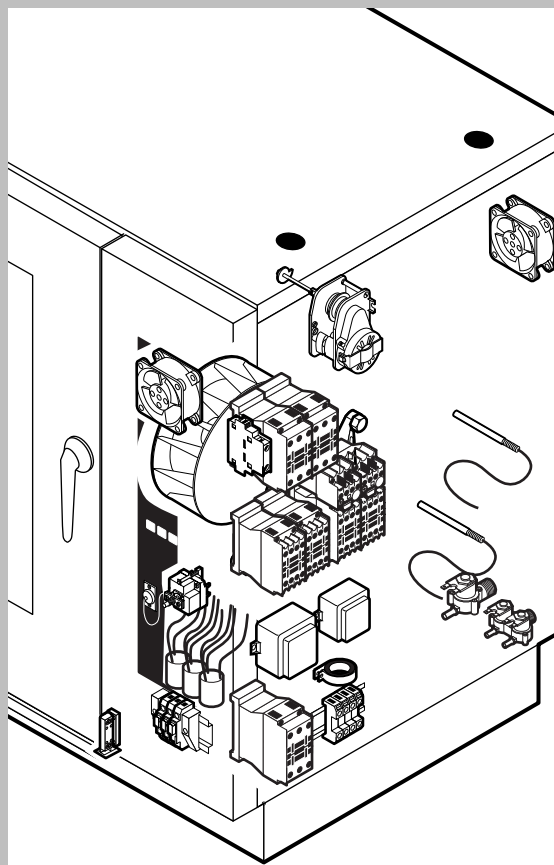

POS.	CODE	PIECES	DESCRIPTION
1	R58003840	1	MOTOR GASKET BRASS FLANGE
2	R58003850	1	MOTOR GASKET BRASS COUNTER FLANGE
3	R58004000	1	FAN SCREW M12x1.5 SX
4	R58004010	1	FAN WASHER Ø 30/12.5
5	R61020562	1	FAN SCREW TE A2 M6x55
6	*R65040051	1	MOTOR HP 1/0.3 KIT UNTIL Nn3705
	*R65040520	1	MOTOR KW 055/015 KIT FROM Nn3805
7	R65060050	2	COMPONENTS VENTILATION MOTOR Ø 120
8	R65070350	1	CHAMBER SAFETY THERMOSTAT
9	R65095000	1	DAMPER SYSTEM
10	R65110200	1	SOLENOID VALVE 220V 50HZ
11	R65110230	1	SOLENOID VALVE 220V 50HZ
12	R65110510	1	1.5 LT/H WATER FLOW REDUCER
13	*R65140550	4	CONTACTOR DIL 00 M-01 4KW
14	*R65140560	3	CONTACTOR DIL 0 M 7,5KW
15	*R65140600	1	AUX.CONTACT 1L+1R 11S DIL M 7,5-15KW
16	*R65160450	1	THERMIC PROTECTION Z 00-1,0
17	*R65160460	1	THERMIC PROTECTION Z 00-2,4
18	R65180420	1	TRANSFORMER 20VA

POS.	CODE	PIECES	DESCRIPTION
19	R65180430	1	TRANSFORMER 40VA
20	R65200086	1	FUSE 0.125A (T)
21	R65200200	1	FUSE 2A
22	R65200040	1	FUSE 0.2A (T)
23	R65210020	3	FUSE CARRIER
24	R65220080	1	TERMINAL BOARD
25	R65265100	1	DOOR SWITCH
26	*R65280200	3	INTERFERENCE SUPPRESSOR
27	*R65280450	1	FERRITE
28	R65325000	2	PROBE PT100
29	R70020050	1	MOTOR GASKET
30	*R75400440	1	FAN Ø 350x114/12 50HZ P.D. KIT

*COMPONENT SUBMITTED TO CHANGEMENTS CAUSED BY TENSION DIFFERENT FROM THE STANDARD (3N AC400V 50HZ)

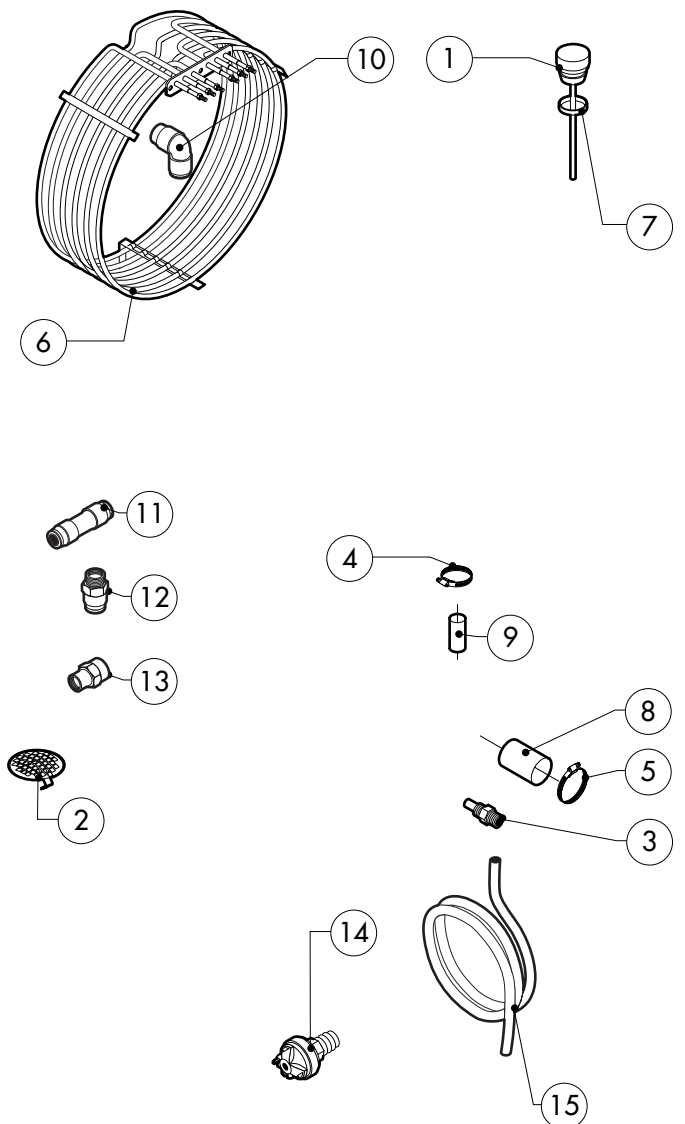
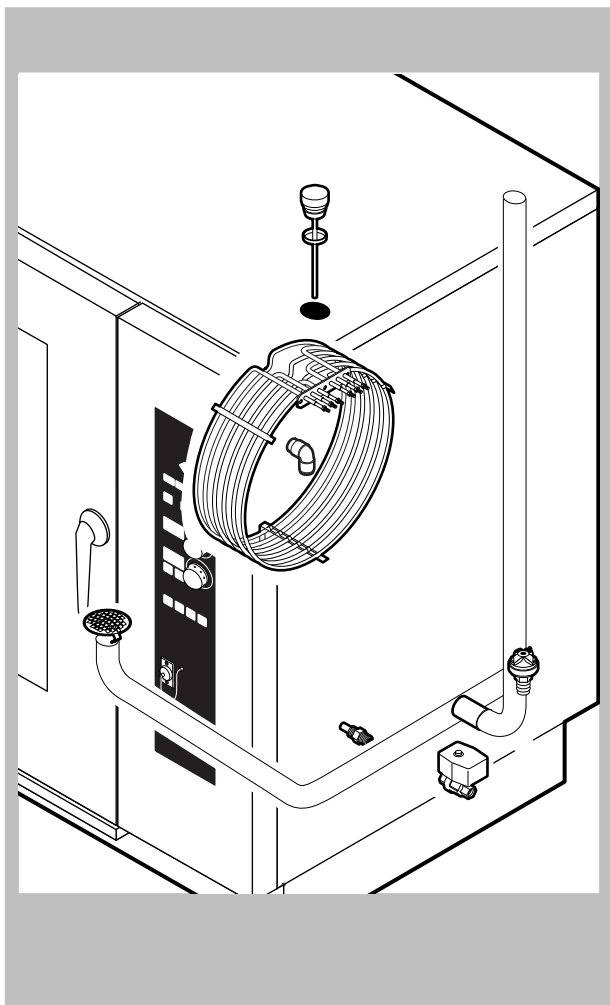

POS.	CODE	PIECES	DESCRIPTION
1	R10100140	1	DAMPER SYSTEM CAP
2	R10201710	1	DRAIN FILTER
3	R58006130	2	STEAM QUENCHING NOZZLE Ø 1
4	R61630011	2	METAL CLAMPS 12-22/9
5	R61630021	2	METAL CLAMPS 30-45/9
6	*R65011310	1	CHAMBER HEATING ELEMENT 15000W
7	R70060020	1	DAMPER SYSTEM CAP GASKET
8	R70060010	1	SILICON COUPLING Ø 30
9	R70060080	1	SILICON COUPLING Ø 13
10	R62090478	3	ELBOW MIDLING PIPE FITTING D.10
11	R62090458	1	STRAIGHT MIDLING PIPE FITTING D.10
12	R62090508	1	10X1/4 STRAIGHT THREADED TERMINAL PIPE FITTING
13	R62030118	1	1/8"-1/4" FEMALE REDUCTION COUPLING
14	R63070050	1	WATER SAFETY PRESSURE SWITCH 1/8" 0,5-0,35 BAR
15	R70070050	1	PE D.10 MM X7 WATER FLEXIBLE PIPE (3 MT LONG)

POS.	CODE	PIECES	DESCRIPTION

*COMPONENT SUBMITTED TO CHANGEMENTS CAUSED BY TENSION DIFFERENT FROM THE STANDARD (3N AC400V 50HZ)

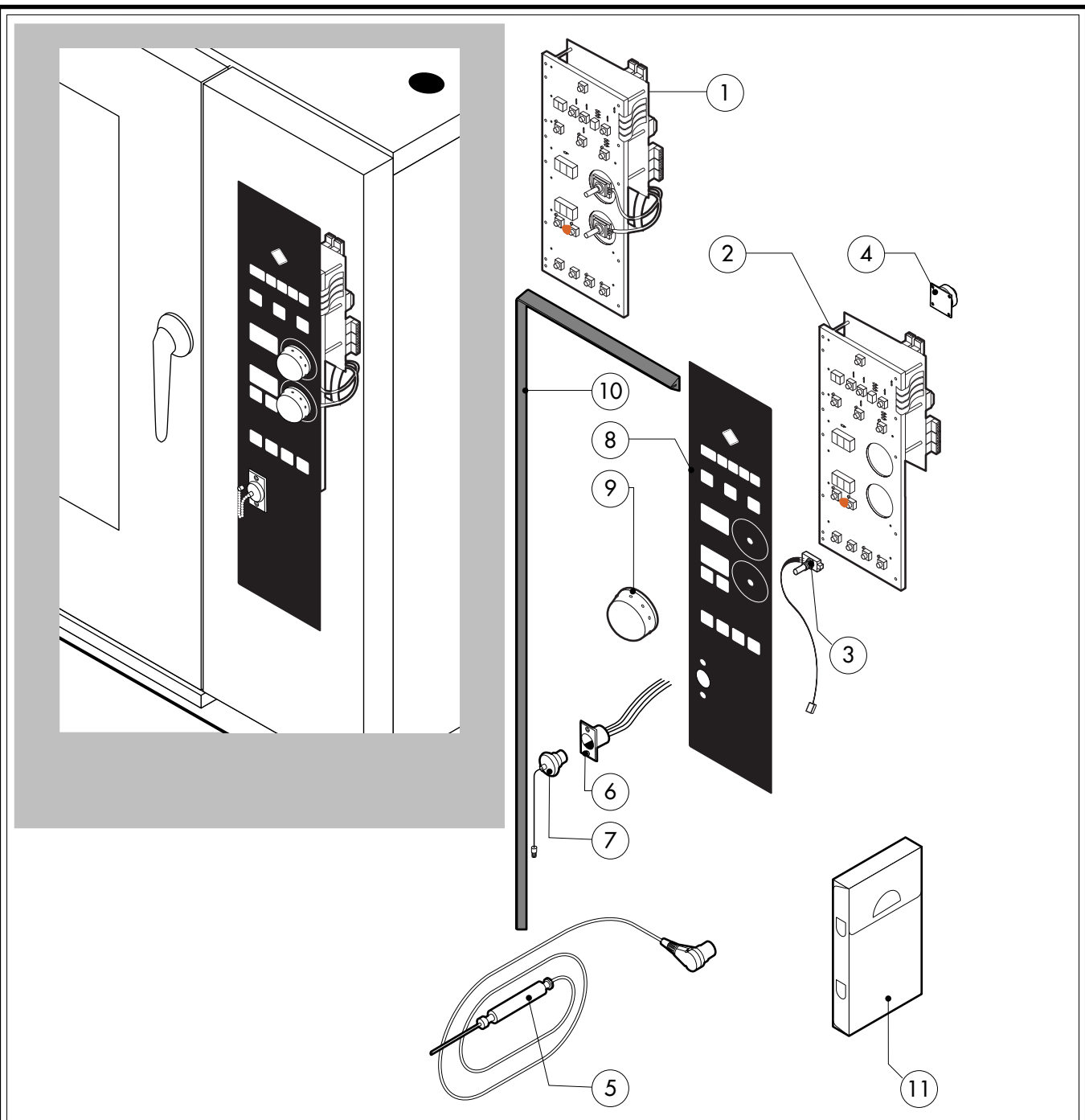

POS.	CODE	PIECES	DESCRIPTION
1	R65301400	1	CONTROL PANEL P.C. BOARD
2	R65301370	1	FRONT+RELAY PC BOARD "H-P" MOD
3	R65301450	2	FRONT PC BOARD ENCODER
4	R65301440	1	PC BOARD BUZZER
5	R65321120	1	CORE TEMPERATURE PROBE
6	R65320920	1	CORE TEMPERATURE PROBE FEMALE CONNECTOR
7	R65321020	1	COVER FOR FEMALE CONNECTOR
8	R67013140	1	PLATE
9	R69030260	2	KNOB
10	R70044400	1	CONTROL PANEL GASKET
11	R86020420	1	CORE TEMPERATURE PROBE BOX

POS.	CODE	PIECES	DESCRIPTION