

		NG CUADRO ELÉCTRICO - CÓDIGOS					
Nº	DENOMINACION	NG30	NG35,45	NG60	NG80	NG110	NG150
1	BASE CUADRO ELÉCTRICO			4789			
2	TAPA CUADRO ELÉCTRICO			4790			
3	TERMOSTATO CICLO			153			
4	MANDO TERMOSTATO			272			
5	PROGRAMADOR 15' 220/50HZ			4864			
	PROGRAMADOR 15' 115/60HZ			4865			
	PROGRAMADOR 20' 220/50HZ			380			
	PROGRAMADOR 20' 115/60HZ			2764			
	PROGRAMADOR 30' 220/50HZ			382			
6	INTERRUPTOR COMPRESOR			2300			
7	TERMOSTATO STOCK			274			
8	ALARGADERA 230V/50Hz			408			
	ALARGADERA 208-230V/60Hz			3675			
	ALARGADERA 115V/60Hz			2771			
9	RETENEDOR CABLE			664			
10	INTERRUPTOR MÁQUINA			2287			
11	RESISTENCIA PVC FLEXIBLE 220V			3814			
	RESISTENCIA PVC FLEXIBLE 115V			4867			
12	REGLETA CONEXIONES			5177 X 3			

S-5.1

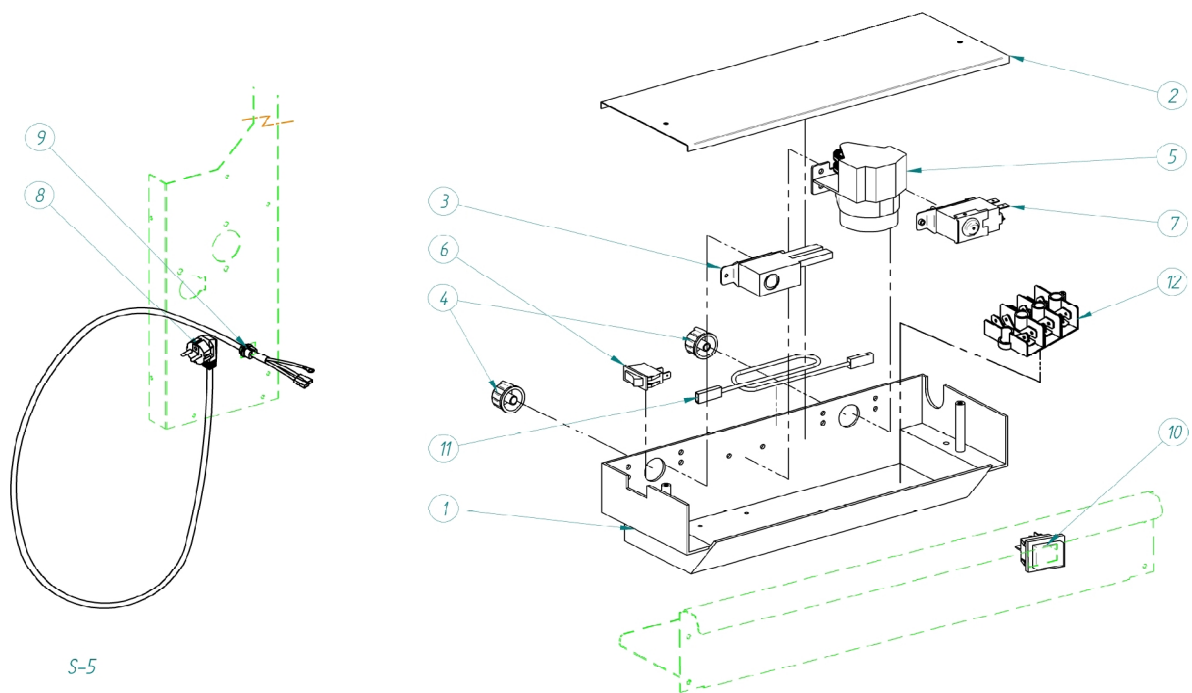

S-5

		NG CUADRO ELÉCTRICO - CÓDIGOS					
Nº	DENOMINACION	NG30	NG35,45	NG60	NG80	NG110	NG150
1	CUADRO ELÉCTRICO			609			
2	CUBIERTA CUADRO ELÉCTRICO			675			
3	TERMOSTATO CICLO			153			
4	MANDO TERMOSTATO			272			
5	PROGRAMADOR 20° 220/50Hz			380			
	PROGRAMADOR 20° 115/60Hz			2764			
6	INTERRUPTOR COMPRESOR			2300			
7	TERMOSTATO STOCK			274			
8	ALARGADERA 230V/50Hz			408			
	ALARGADERA 208-230V/60Hz						
	ALARGADERA 115V/60Hz			2771			
9	RETENEDOR CABLE			664			
10	INTERRUPTOR MÁQUINA			2287			
11	RESISTENCIA PVC FLEXIBLE			3814			
12	REGLETA CONEXIONES			5177 X 3			

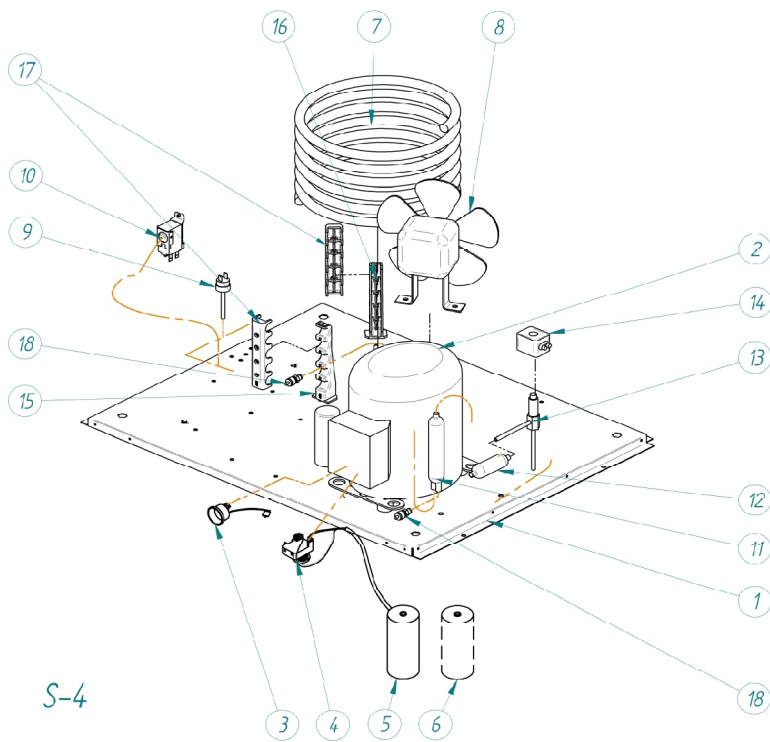

NG UNIDAD CONDENSADORA DE AGUA - CÓDIGOS								
Nº	DENOMINACIÓN	NG30	NG35	NG45	NG60	NG80	NG110	NG150
1	BANCADA	2836	808		4160	1734	3258	4313
2	COMPRESOR	230/50HZ	435	436	437	438	439	441
		220/60HZ	1095	1098	1099
		115/60HZ	2807	2808
3	CLIXON	230/50HZ	3454	3455	3456	3457	3458	3460
		115/60HZ	4360
4	RELÉ	230/50HZ	3463	3464	3465	3466	3467	3469
		115/60HZ	3555
5	COND. ARRANQUE	220/50HZ	3471	3472	3474	3475	3475
		115/60HZ	4359
6	COND. PERMAN.	220/50HZ	3478	3479
		115/60HZ
7	CONDENSADOR AGUA	5736	5242	5243	5244		5246	3267
8	VENTILADOR	2170	443		444	
9	PRESOSTATO SEGURIDAD	334			334		2683
10	PRESOSTATO CONDENSACIÓN	2507					
11	DESHIDRATADOR	1717					1096	2560
12	FILTRO VALV. GAS CALIENTE	448					
13	VALV. GAS CALIENTE	1473					
14	BOBINA ENGASTADA 220V	5173					
	BOBINA ENGASTADA 115/60HZ	5414					
15	SOPORTE CONDENS W ALTO	4036					
16	SOPORTE CONDENS W BAJO	4037					
17	SOPORTE CONDENS W EXTERIOR	4038					
18	VÁLVULA CARGA REFRIGERANTE	335					

S-4 29/05/08

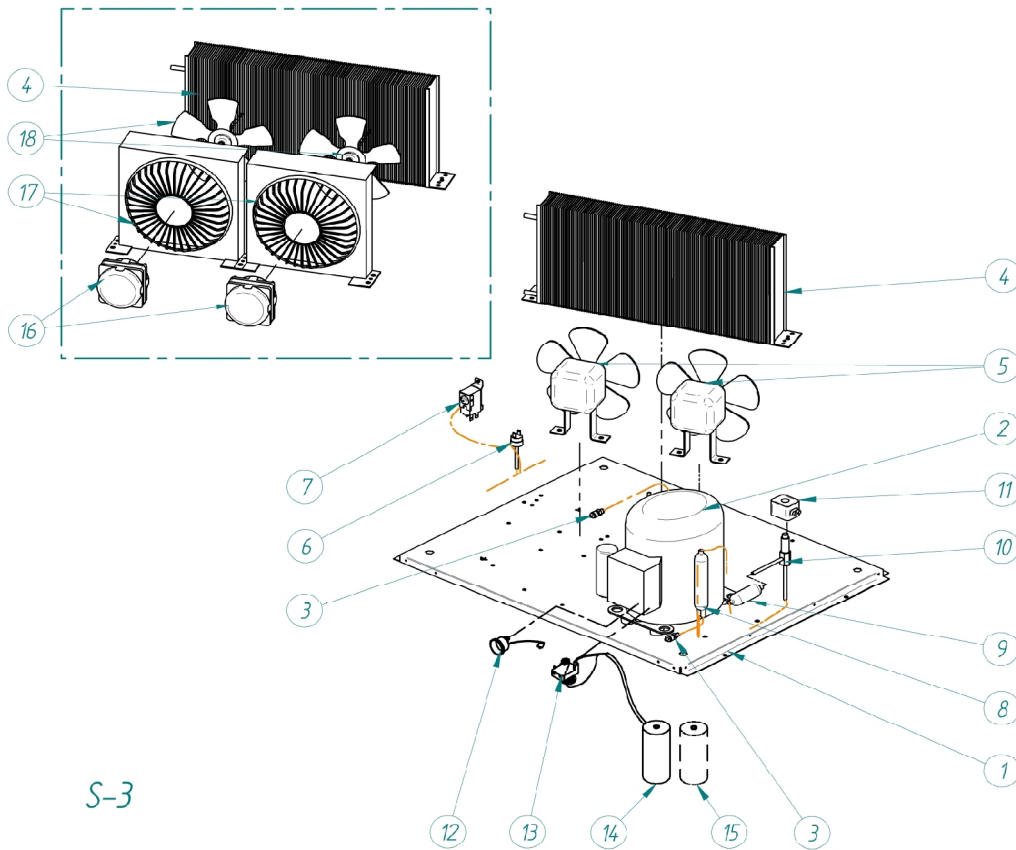

S-3

NG UNIDAD CONDENSADORA DE AIRE - CÓDIGOS								
Nº	DENOMINACION	NG30	NG35	NG45	NG60	NG80	NG110	NG150
1	BANCADA	2836	808		4160	1734	3258	4313
2	COMPRESOR	230/50HZ	435	436	437	438	439	441
		220/60HZ	1093	1095	1098	1099
		115/60HZ	2802	2807		2808
12	CLIXON	230/50HZ	3454	3456	3457	3458	3460
		220/60HZ
		115/60HZ		4360	
13	RELE	230/50HZ	3463	3464	3465	3466	3467	3469
		220/60HZ
		115/60HZ		3555	
14	CONDENS ARR	220/50HZ	3471	3472	3473	3474		3475
		220/60HZ
		115/60HZ
15	CONDENS PER	220/50HZ	3478	3479
		220/60HZ
		115/60HZ	2257
3	VÁLVULA CARGA REFRIG.				335			
4	CONDENSADOR AIRE	2423	487		2867	2593	2593	2618
5	VENTILADOR		28			444	
6	PRESOSTATO SEGURIDAD			334			2683	
7	PRESOSTATO CONDENSACION				2507			
8	DESHIDRATADOR			1717			1096	2560
9	FILTRO VALV. GAS CALIENTE				448			
10	VALV. GAS CALIENTE				1473			
11	BOBINA VALV. 230/50Hz				5173			
	BOBINA VÁLV. 115/60HZ				5414			
16	MOTOR VENTILADOR	2421	4131	4230
17	BAFFLE CONDENSADOR	2422	2433	2435
18	PALA VENTILADOR	587	4040	4495

S-3 1/10/08

NG CUBAS - CODIGOS						
Nº	DENOMINACIÓN	NG35, 45	NG60	NG80	NG110	NG150
1	CUBA STOCK	7452	7388	7128	7322	7487
2	TAPA CUBETA BOMBA			1938		
3	REJILLA EXPULSORA	4673	1147	2186	3805	4323
4	SOPORTE CORTINA	121	4055		2187	4193
5	CLIP SOPORTE CORTINA			3533		
6	COLECTOR COMPLETO	7464	7406	7335	7350	7485
	SUPERSTAR	7464	7439	7432	7433	7486
7	TUBO IMPULSIÓN		2148		2191	2148+574+2191
8	INYECTOR PLANO			526		
9	BOMBA 220/50HZ		5563	5405	5494	5927
	115/60HZ		5850	5932	5545	5777
10	FILTRO BOMBA			1712		
11	CORTINA COMPLETA	5900	5837		5395	5929
12	LAMA EXTERIOR			606		
13	LAMA INTERIOR			605		
14	JUNTA ARTICULACIÓN			107		
15	ELECTROVÁLVULA 1B			329		
16	ELECTROVÁLVULA 2B			404		
17	TUBO DESAGÜE			2222		
18	COLECTOR DESAGÜE			363		
19	JUNTA TUBO TERMOSTATO			666		
20	TUBO TERMOSTATO	5219	5437	5422	5422	5933
	EVAPORADOR				
	ALFA 20gr	7030	7258	7258	7263	7479
	GALA 30gr	7423	7400	7156	7352	7480
	DELTA 40gr	7031	7401	7252	7095	7437
21	SUPERSTAR 60gr	7032	7436	7323	7355	7427
22	TAPA EVAPORADOR	5899	5418	5406	5491	5928
23	DISTRIBUIDOR AGUA	2647			911	
24	DESAGÜE REBOSADERO			4425		
25	JUNTA TORICA			4496		-
26	REBOSADERO			4426		1134
27	TAPA REBOSADERO			-		

S-2 01/10/2008

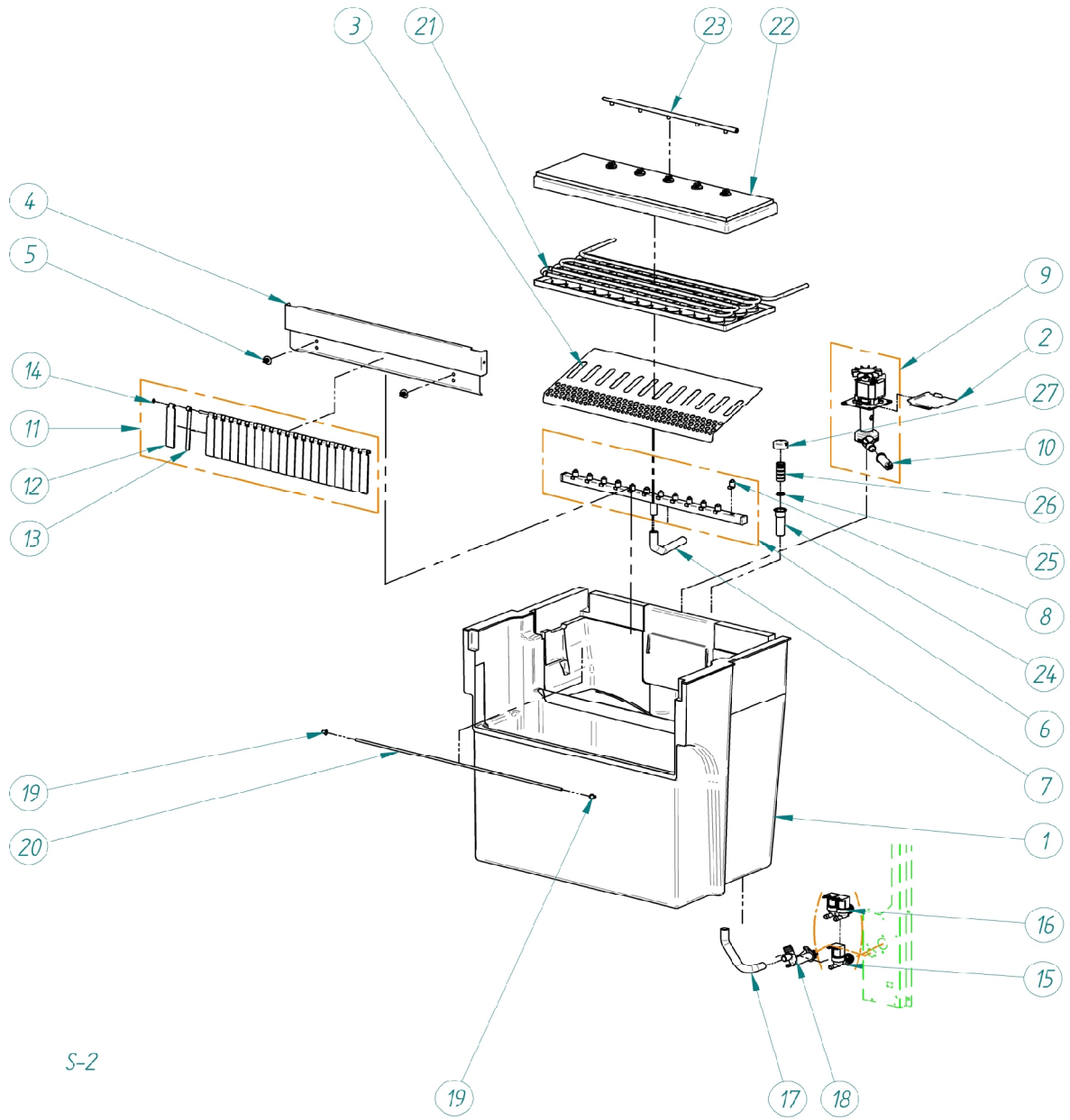

S-2

NG - CARROCERIA códigos.							
Nº	DENOMINACIÓN	NG30	NG35, 45	NG60	NG80	NG110	NG150
1	BANCADA	2836	808	4160	1734	3258	4313
2	PUENTE	3078	506	4159	1735	3421	4314
3	PILAR DELANTERO DCHO	3292	159	159	1736	3434	
4	PILAR DELANTERO IZDO	3293	160	160	1737	3435	
5	PILAR TRASERO ACOMETIDA	3407	207	207	1775	3746	
6	PILAR TRASERO	3406	161	161	1770	3436	
7	LATERAL DCHO	4219	489	489	1900	3969	
8	LATERAL IZDO	4220	490	490	1901	3970	
9	TIRANTE LATERAL	3520	557	557		3778	
10	TRASERA	4223	635	4172	1807	3785	4320
11	REFUERZO TRASERO	3528	2112	4171	1800		4325
12	REJILLA TRASERA	1728	4088	2192		
13	FRENTE INFERIOR	3079	418	4168	1790	3770	4315
14	FRENTE SUPERIOR		421	4169	1791		4316
15	PUERTA	5072	5030	5791	5237		5857
16	REJILLA AIREACION		4063	4388	4188		4187
17	ANGULO PUENTE	2331
18	REFUERZO CUBIERTA	4146		4326
19	CUBIERTA	3387	920	4170	1792	3773	4317
20	MUELLE PUERTA	702					
21	TOPE COMPÁS	156					
22	PATA	1478					
23	REMATE BOCA DCHO	82					
24	REMATE BOCA IZDO	83					
25	CLIP REMATE BOCA	113					
26	CASQUILLO EJE PUERTA NG	155					
27	COJINETE PUERTA NG	1001					
28	TORNILLO EJE PUERTA	392					

S-1 26/09/2009

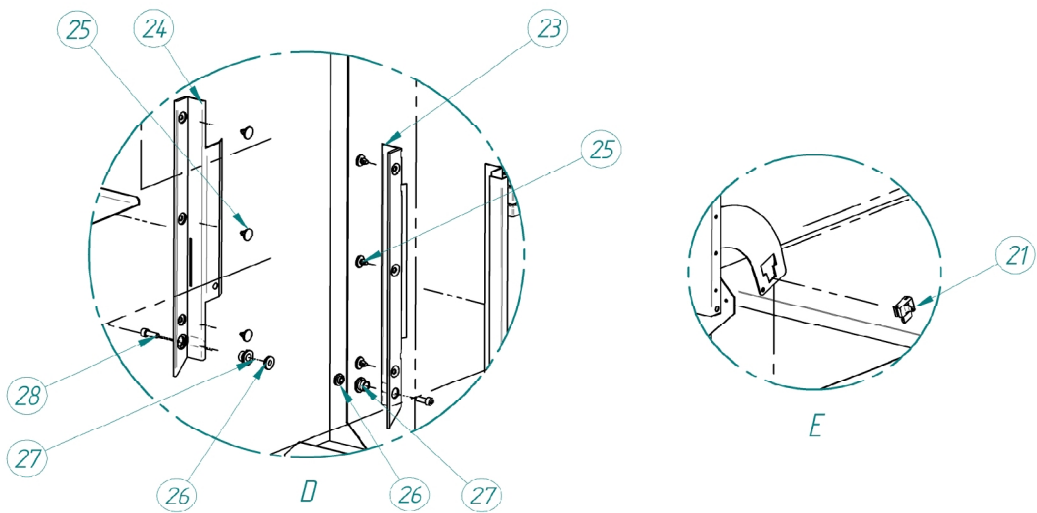
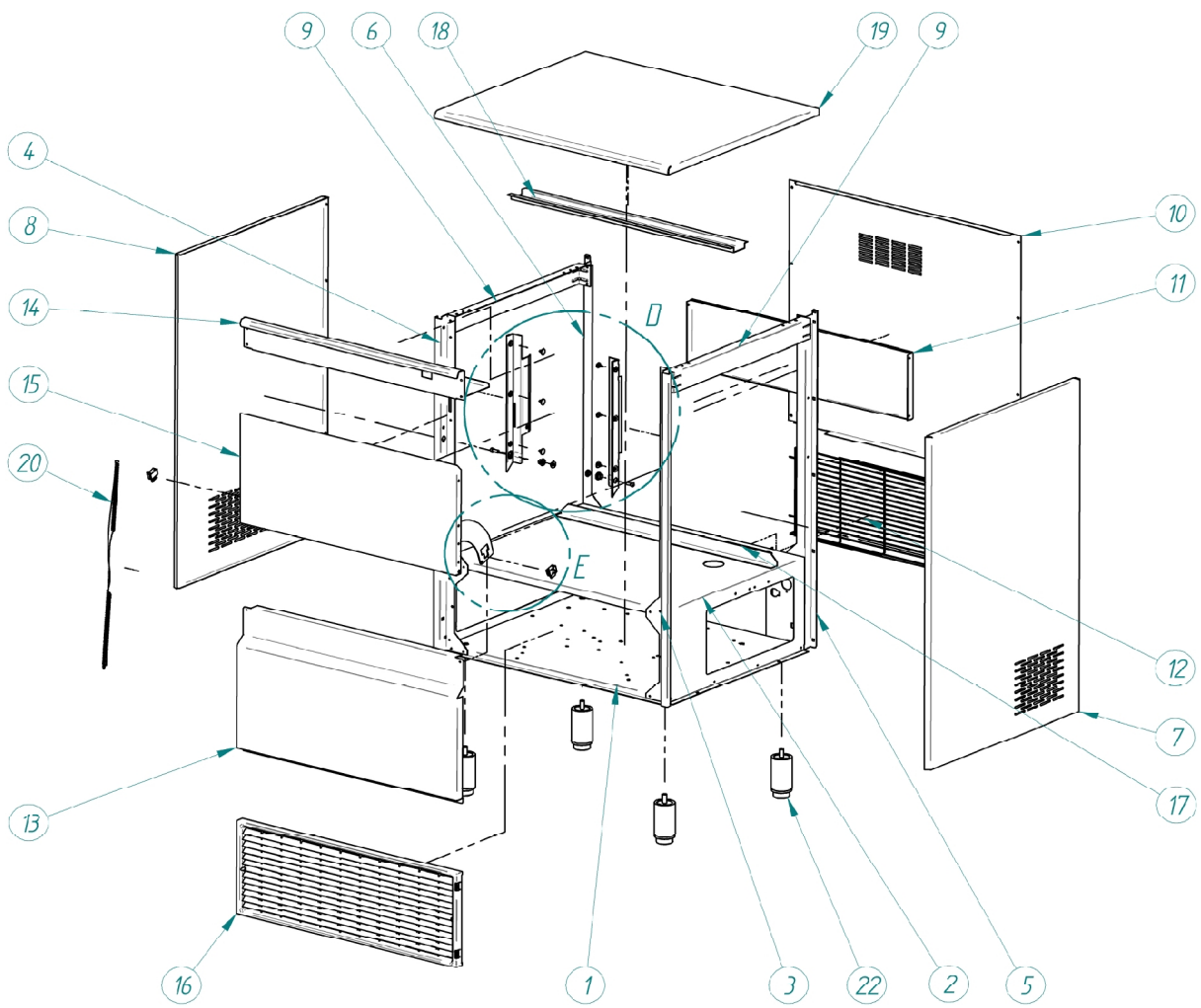

S-1