

**CATALOGO RICAMBI  
SPARE PARTS  
PIECES DETACHEES  
ERSATZTEILE  
LISTA DE RECAMBIOS**

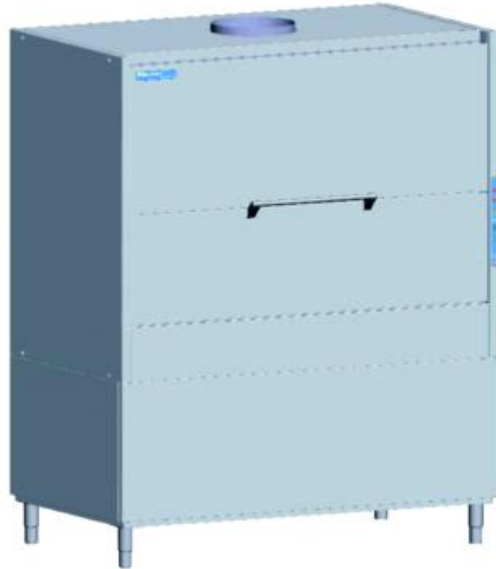

**Lavaoggetti  
Utensil and pot washer  
Lave batterie  
Gerätespülmaschinen  
Lavautensilios**

**HD 60/80/130 BT  
LB 67/83/134 BT**

Ed. 07/2012

- 1 Hood
- 2 Door Components
- 3 Wash Pump
- 4 Wash Arm
- 5 Wash Arm
- 6 Filter / Drain
- 7 Rinse Assembly
- 8 Rinse Pump
- 9 Control Box
- 10 Rinse Aid Injector
- 11 Detergent Pump
- 12 Drain Pump

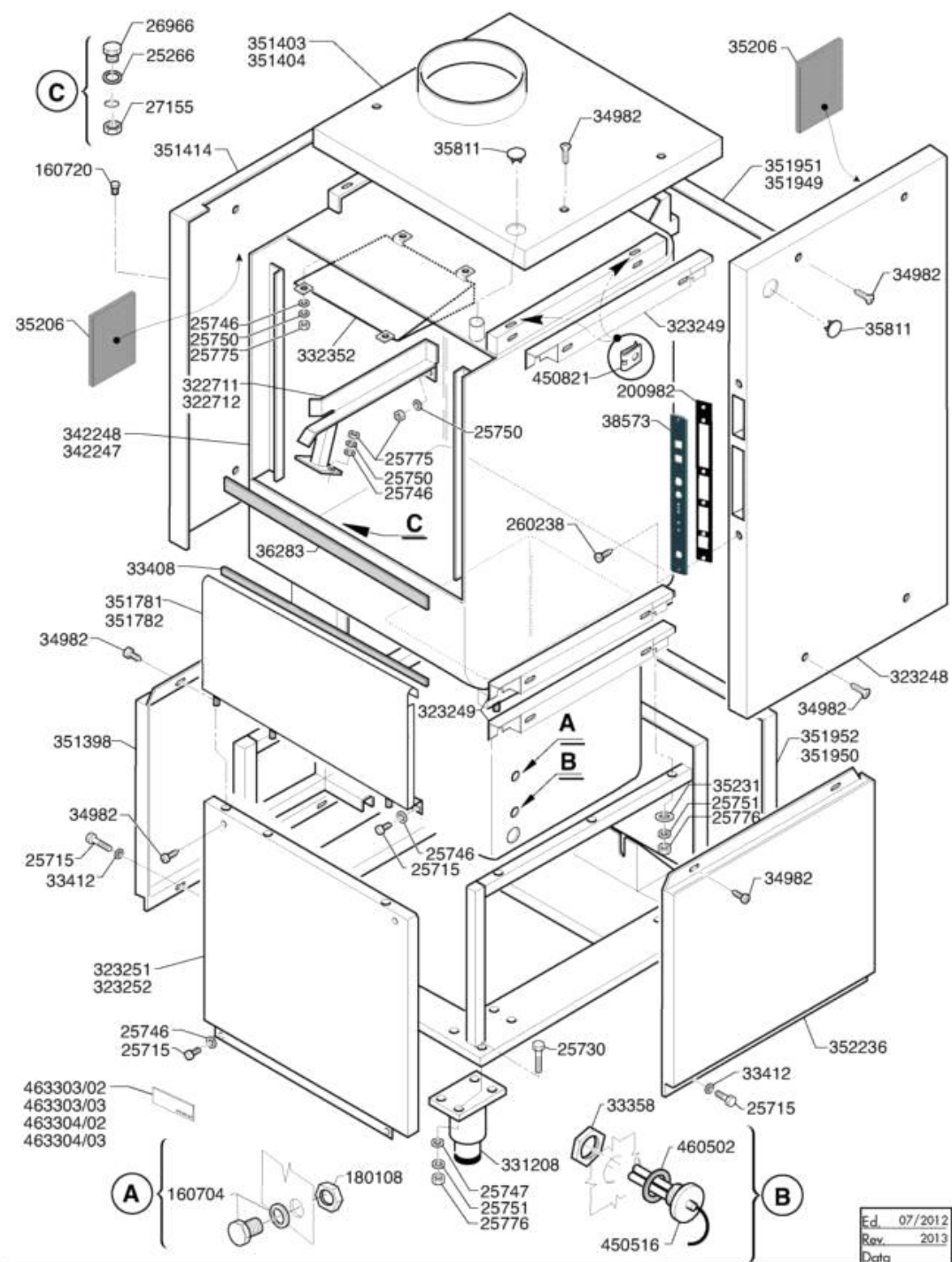

Ed.	07/2012
Rev.	2013
Date	

Code	Description	
160704	TAPP. NERI CON GUAR. 1/2" GAKT20	
160720	TAPPO A SCATTO HEYCO D.8	
180108	GHIERA 1/2" GAS PLASTICA	
200982	GUARN. GOMMA SUPPOR. TARGA HD BT	
25266	FLAT GASKET 18 X 10 X 2	
25715	SCREW HEX. HD M 6 X 16 SS	
25730	SCREW HEX. HD M 8 X 25	
25746	SPACER, FLAT, DIAM. 6/18	
25747	SPACER, FLAT, DIAM. 8	
25750	SPACER, SPLITTED, DIAM. 6	
25751	SPACER. SPLITTED, DIAM. 8	
25775	NUT 6 MA	
25776	NUTS 8 MA SS 18/8	
260238	VITE INOX "TB" 4x10	
26966	HOLE CLOSING PLUG	
27155	PLASTIC NUT 10 M	
322711	GUIDA CESTELLO DX GE/EDI	
322712	GUIDA CESTELLO SX GE/EDI	
323248	PANNELL. COM. LAT. DX HD 60/80/130	
323249	TRAVERSA SUPP. PANN. LAT. DX INF.	
323251	PANNELLO ANTERIORE HD 60	
323252	PANNELLO ANTERIORE HD 80	
331208	PIEDE TELESCOPICO INOX	
332352	PARASPRUZZI VAP. "GE/EDI"	
33358	LOCK NUT 1/2" ES. 30 SP. 7" SS	
33408	NEOPREN ADHESIVE GASKET 8 X 4	
33412	PRESSED WASHER 7x22x2	
342247	CARROZZ. + BASAM. EDI 8	
342248	CARROZZ. + BASAM. EDI 6	
34982	SCREW M5X12, HALF-ROUND HD. COMBI	
351398	PANN. LAT. SX BASAMENTO GE/EDI	
351403	PANN. SUP. TETTO GE60-65/EDI6	
351404	PANN. SUP. TETTO GE80-85/EDI8	
351414	PANNELLO LAT. SX GE/EDI	
351781	FRONTALINO VASCA GE60-65/EDI6	
351782	FRONTALINO VASCA GE80-85/EDI8	
351949	PANNELLO POST. SUPER. GE85/EDI8	
351950	PANNELLO POST. BASAM. GE85/EDI8	
351951	PANNELLO POST. SUPER. GE65/EDI6	
351952	PANNELLO POST. BASAM. GE65/EDI6	
35206	INSULATION 250x125x30	
352236	PANN. LAT. DX BASAM. HD 60/80/130	
35231	FLAT WASHER 8 X 24	
35811	SNAP PLUG, FASTPOINT/3586	
36283	SELF-ADHESIVE GASKET 20X10	

Code	Description	
38573	SUPPORTO TARGA COM.HD con PRIG	
450516	GUAINA TERM. 2 TUBI INOX H=109	
450821	PIASTRINA FASTNER 5 MA	
460502	GUARNIZ. 30X21X2 KLINGER 1/2"	
463303/02	DOX SYSTEM HD 60 BT	
463303/03	DOX SYSTEM HD 80 BT	
463304/02	DOX SYSTEM LB 67 BT	
463304/03	DOX SYSTEM LB 83 BT	

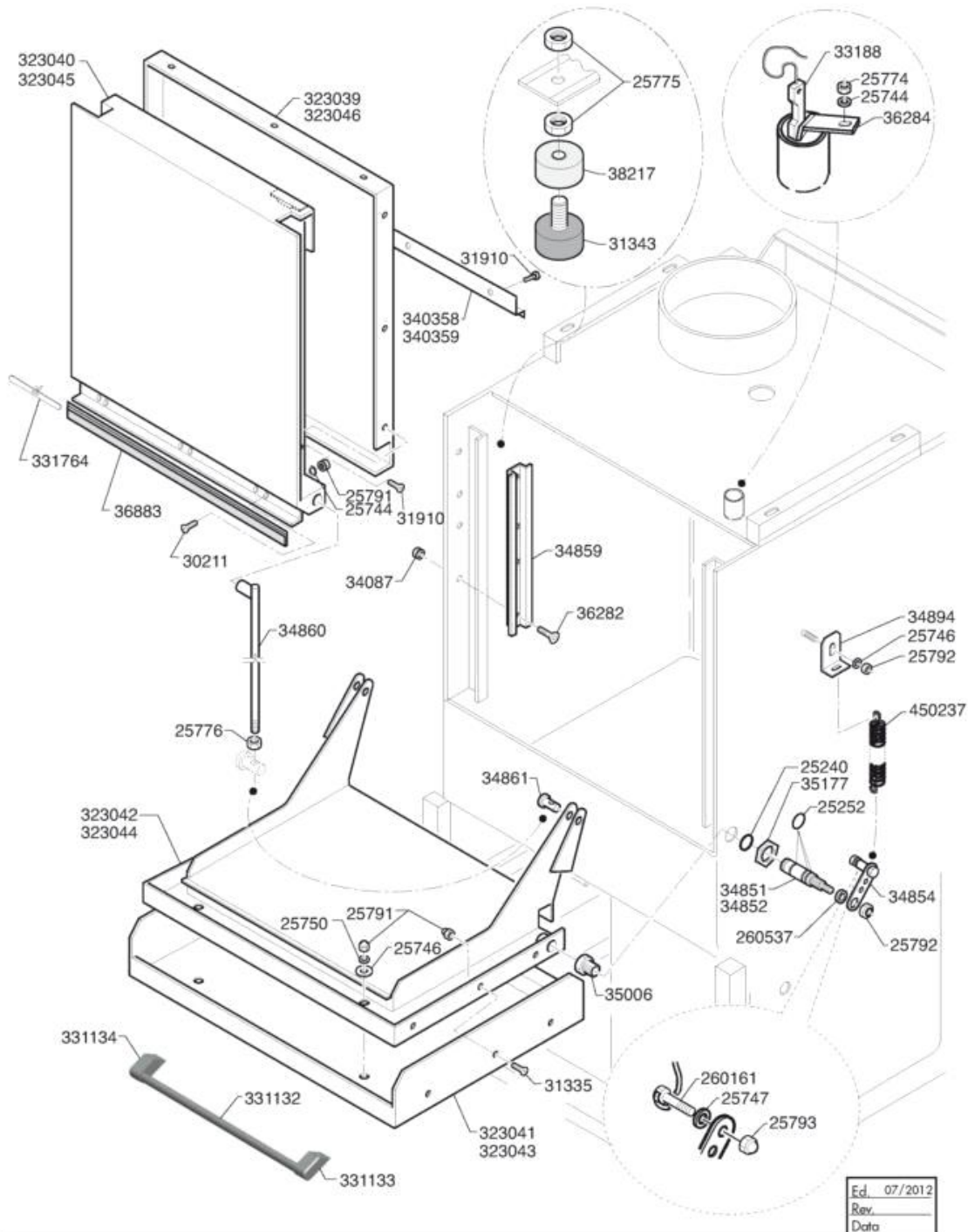

## Door Components

Code	Description	
25240	GASKET OR 121	
25252	GASKET OR 108	
25744	SPACER, FLAT, DIAM.5	
25746	SPACER, FLAT, DIAM.6/18	
25747	SPACER, FLAT, DIAM. 8	
25750	SPACER, SPLITTED, DIAM. 6	
25774	NUTS 5 MA	
25775	NUT 6 MA	
25776	NUTS 8 MA SS 18/8	
25791	SELF-LOCKING NUT 5 MA LOWER SIDE	
25792	SELF-LOCKING NUT 6 MA LOWER SIDE	
25793	SELF-LOCKING NUT 8 MA LOWER SIDE	
260161	VITE SPEC.FISS.MOLLA PORTA GE	
260537	RONDEL.INOX D.13X20X0,8-6592	
30211	HEX.HD. SCREW 5 X 12	
31335	BEVEL-HD SCREW 5X8, SPECIAL	
31343	SHOCK ABSORBER, DOOR ED 630/90	
31910	HALF-ROUND SCREW 5 X 8T	
323039	CONTROPORTA SUP.GE60-65/EDI6	
323040	PORTA SUP.GE60-65/EDI6	
323041	PORTA INFER.GE60-65/EDI6	
323042	CONTROPORTA INF.GE65/EDI6	
323043	PORTA INFER.GE80-85/EDI8	
323044	CONTROPORTA INF.GE85/EDI8	
323045	PORTA SUPER.GE80-85/EDI8	
323046	CONTROPORTA SUP.GE85/EDI8	
331132	TUBO MANIGLIA HDBT	
331133	SUPPORTO MANIGL.DX HDBT(LUCID)	
331134	SUPPORTO MANIGL.SX HDBT(LUCID)	
331764	PIASTRINA FISS.GOMMA PORTA EDI	
33188	MAGNETIC SENSOR	
340358	ANGOLARE PARASP.PORTA GE60-65	
340359	ANGOL.PAR.PORTA SUP.GE85/EDI8	
34087	FLANGED NUT M5 A2 DIN 6923	
34851	DOOR PIVOT, EDI, LEFT	
34852	DOOR PIVOT, EDI, RIGHT	
34854	COMPENSAT.LEVER FOR DOOR EDI	
34859	UPPER DOOR GUIDE, EDI	
34860	DOOR-RAIS. STAY, UPPER, EDI	
34861	DOOR-RAIS. STAY PIVOT, EDI	
34894	SPRING CLIPPING BRACKET, EDI	
35006	BUSH, HOUSING, SERIES EDI	
35177	NUT 3/8"G SS	
36282	VITE TC 5 X 30 INOX DIN7985 A2	
36284	MAGNET FIXING PLATE	

## Door Components

Code	Description	
36883	GASKET FOR DOOR 10x16 sh50	
38217	CAPSULA INOX x AMMOR.PORTA EDI	
450237	MOLLA x PORTA GE/EDI	



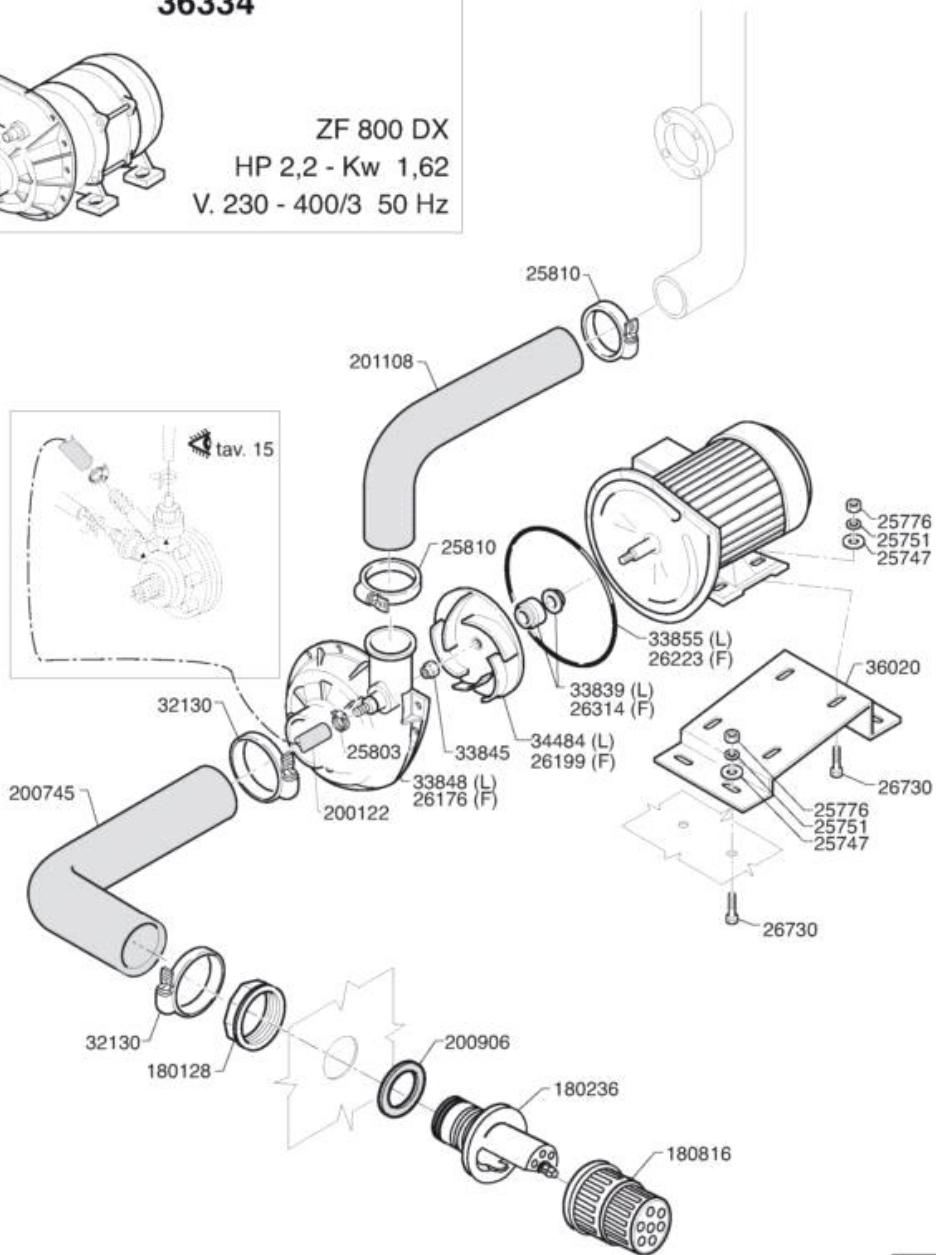

Ed.	07/2012
Rev.	
Date	

## Wash Pump

Code	Description	
180128	GHIERA FIL 65,4 C140 C85-155	
180236	TRONCHETTO ASPIR.CON DEF.	
180816	FILTRO ASPIRAZIONE D.82 -	
200122	TUBO GOMMA 11X19 CASER/15 BLU	
200745	MANICOTTO ASP.prel.ACR.NE/SNL	
200906	GUARNIZIONE D. 92x66x2	
201108	MANICOTTO MAND.GE755 (HV35020)	
25747	SPACER, FLAT, DIAM. 8	
25751	SPACER. SPLITTED, DIAM. 8	
25776	NUTS 8 MA SS 18/8	
25803	HOSE CLIP 13-20 ABA	
25810	HOSE CLIP 55-70	
26176	COVER, WASH PUMP HP 3 RIGHT	
26199	IMPELLER WASH P.HP2 DX OPENED	
26223	GASKET, COVER PUMP	
26314	SHAFT SEAL, WASH PUMP HP 1,5/2	
26730	SCREW TE M 8 X 20	
32130	HOSE CLIP 60-80	
33839	MECH. SEAL PR/AR 13 BEFF	
33845	NUT M8, RIGHT H=5 MM	
33848	PUMP HOUS.ZF650 RIGHT A60/M50 HOSE	
33855	GASKET OR. 158.34*3.53	
34484	IMPELLER 120 6-BLADE, RIGHT ZF 800	
36020	WASH PUMP SUPPORT.PLATE, EDI	
36334	ELECTR.HP 2,2Right 230/400V3 50Hz	

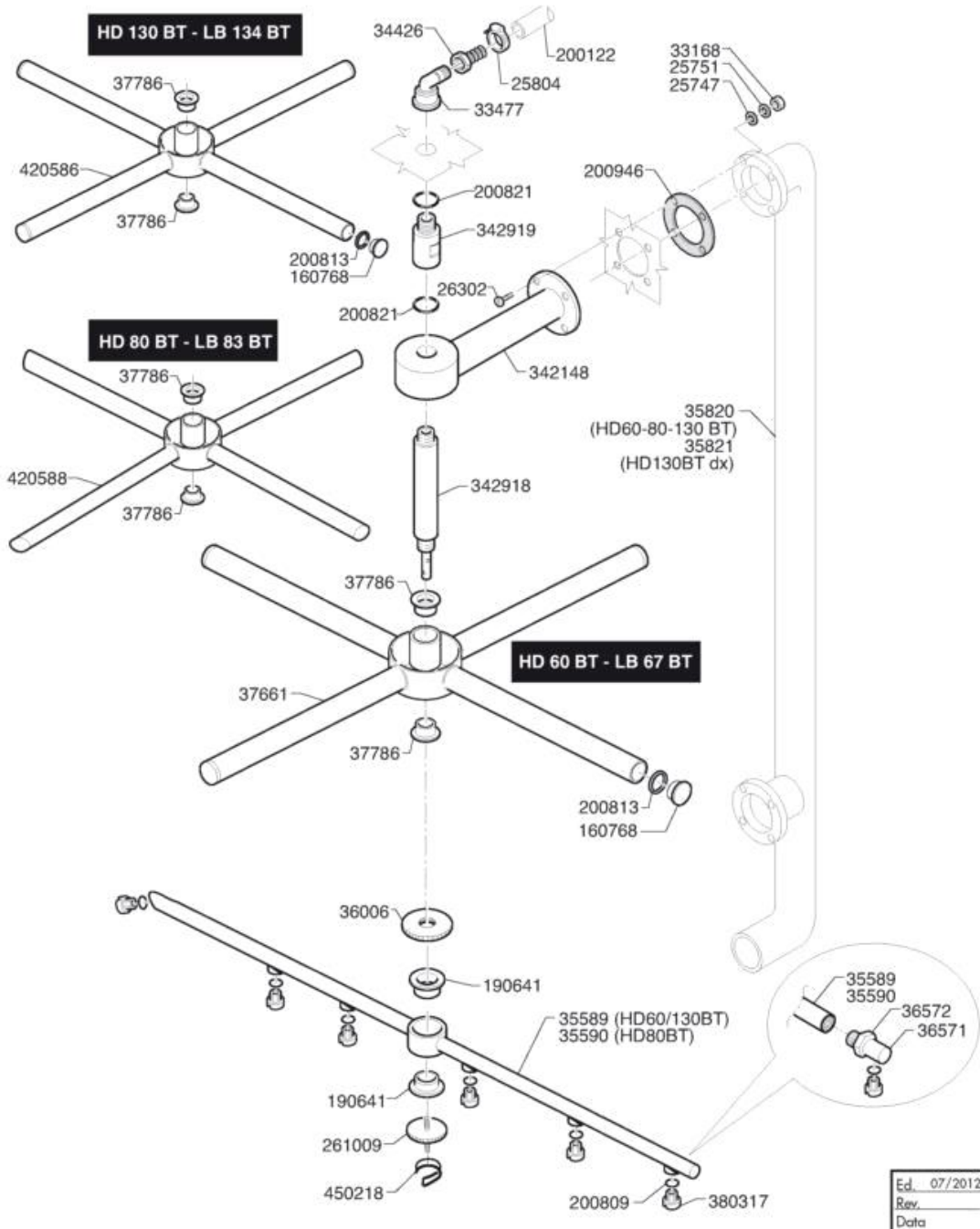

Code	Description	
160768	TAPPO X MULINELLO LAV. "C"	
190641	BUSSOLA MULIN.RISC."C" V.S.	
200122	TUBO GOMMA 11X19 CASER/15 BLU	
200809	GUARN.OR 1,78X7,66X11,21 VITON	
200813	GUARNIZ. OR 2,21x16,36x20,78	
200821	GUARN.OR 2,62X20,63X25,87	
200946	GUARNIZ.COLONNA LAV.GE(HV34899	
25747	SPACER, FLAT, DIAM. 8	
25751	SPACER. SPLITTED, DIAM. 8	
25804	HOSE CLIP 15-24 ABA	
261009	VITE FISS. MULINELLO TUB.ACC.	
26302	HEX HD.SCREW M6X35, STAINLESS S.	
33168	DADO CIECO 8 MA	
33477	ELBOW FEM/FEM. 3/8 1/4 C140-155	
342148	SUPPORTO MULINELLO G ANNO 2010	
342918	ALBERINO x MUL. G 2010 (37244)	
342919	PROLUNGA ALIM.RISC.SUP.GE 2010	
34426	PIPE UNION 1/4 G FOR C90	
35589	REVOLV. RINSE ARM, EDI 6/13 -2?	
35590	REVOLV. RINSE ARM, EDI 8 - 2?	
35820	WASH DELIV.PIPE EDI 2?	
35821	WASH DELIV.PIPE, RIGHT, EDI 13 2?	
36006	S.S.304 BUSHING, REVOLV.WASHARM	
36571	FEED PIPE REG. , RINSE ARM EDI	
36572	NUT M14x1RINSE ROTATION ARM EDI	
37661	MULINELLO LAVAGGIO C 98 2007	
37786	BUSSOLA CORPO MUL.LAV. C90E	
380317	NEBULIZZ. OV 1/8" 303 125lt 80	
420586	MUL.LAV.MOZZO FUSO X GE605	
420588	MUL.LAV.MOZZO FUSO X GE805	
450218	MOLLA FISS.VITE MULIN.C95-155	

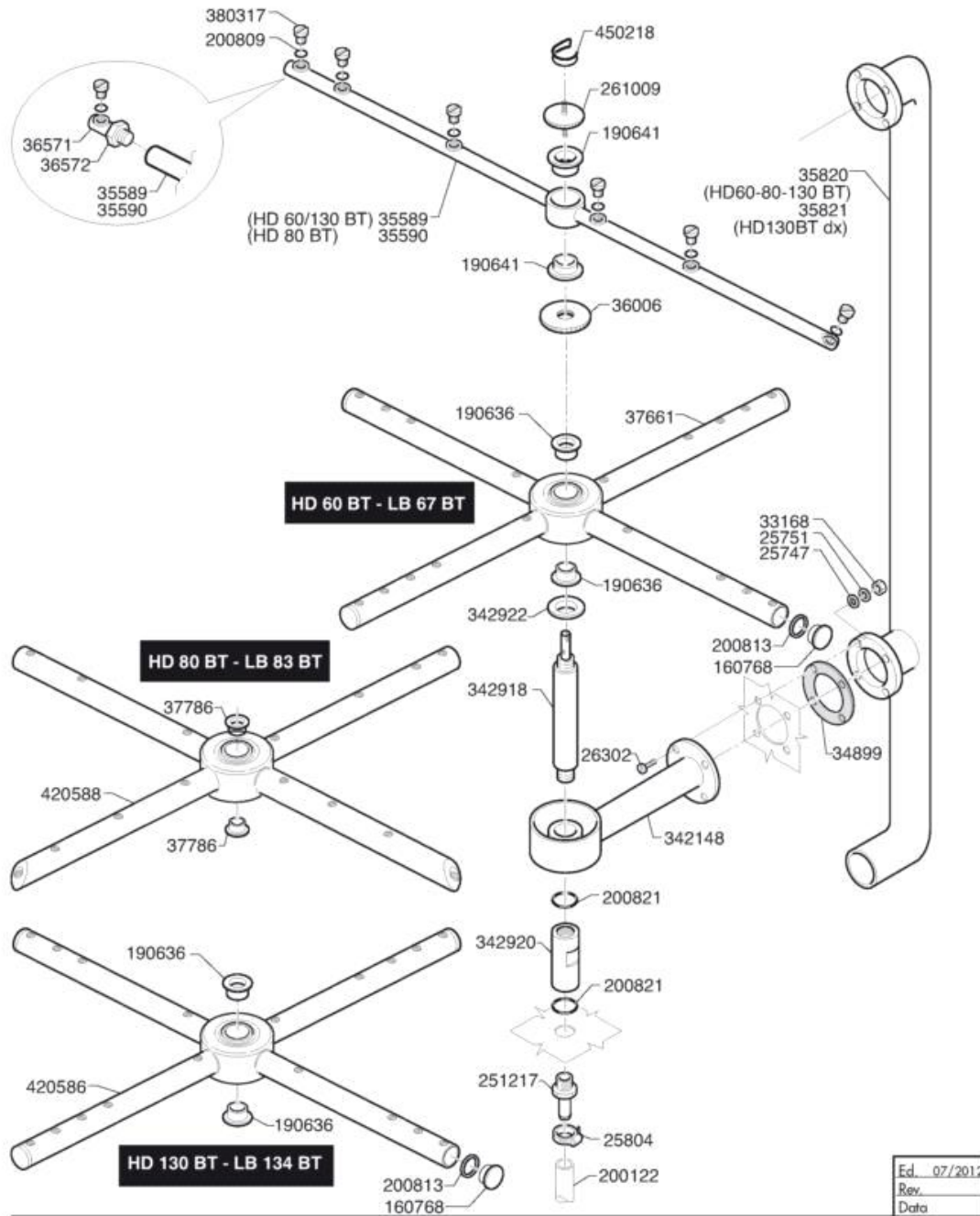

Code	Description	
160768	TAPPO X MULINELLO LAV. "C"	
190636	BUSSOLA x MULINELLO LAV. C90E	
190641	BUSSOLA MULIN.RISC."C" V.S.	
200122	TUBO GOMMA 11X19 CASER/15 BLU	
200809	GUARN.OR 1,78X7,66X11,21 VITON	
200813	GUARNIZ. OR 2,21x16,36x20,78	
200821	GUARN.OR 2,62X20,63X25,87	
251217	PORTAG.INOX 3/8 MASCHIO GE65	
25747	SPACER, FLAT, DIAM. 8	
25751	SPACER. SPLITTED, DIAM. 8	
25804	HOSE CLIP 15-24 ABA	
261009	VITE FISS. MULINELLO TUB.ACC.	
26302	HEX HD.SCREW M6X35, STAINLESS S.	
33168	DADO CIECO 8 MA	
342148	SUPPORTO MULINELLO G ANNO 2010	
342918	ALBERINO x MUL. G 2010 (37244)	
342920	PROLUNGA ALIM.RISC.INF.GE 2010	
342922	DISTANZ.x MUL.INF.GE PIPE FUSE	
34899	GASKET FOR DELIV.HOSE FLANGE, EDI	
35589	REVLV. RINSE ARM, EDI 6/13 -2?	
35590	REVLV. RINSE ARM, EDI 8 - 2?	
35820	WASH DELIV.PIPE EDI 2?	
35821	WASH DELIV.PIPE, RIGHT, EDI 13 2?	
36006	S.S.304 BUSHING, REVLV.WASHARM	
36571	FEED PIPE REG. , RINSE ARM EDI	
36572	NUT M14x1RINSE ROTATION ARM EDI	
37661	MULINELLO LAVAGGIO C 98 2007	
37786	BUSSOLA CORPO MUL.LAV. C90E	
380317	NEBULIZZ. OV 1/8" 303 125lt 80	
420586	MUL.LAV.MOZZO FUSO X GE605	
420588	MUL.LAV.MOZZO FUSO X GE805	
450218	MOLLA FISS.VITE MULIN.C95-155	

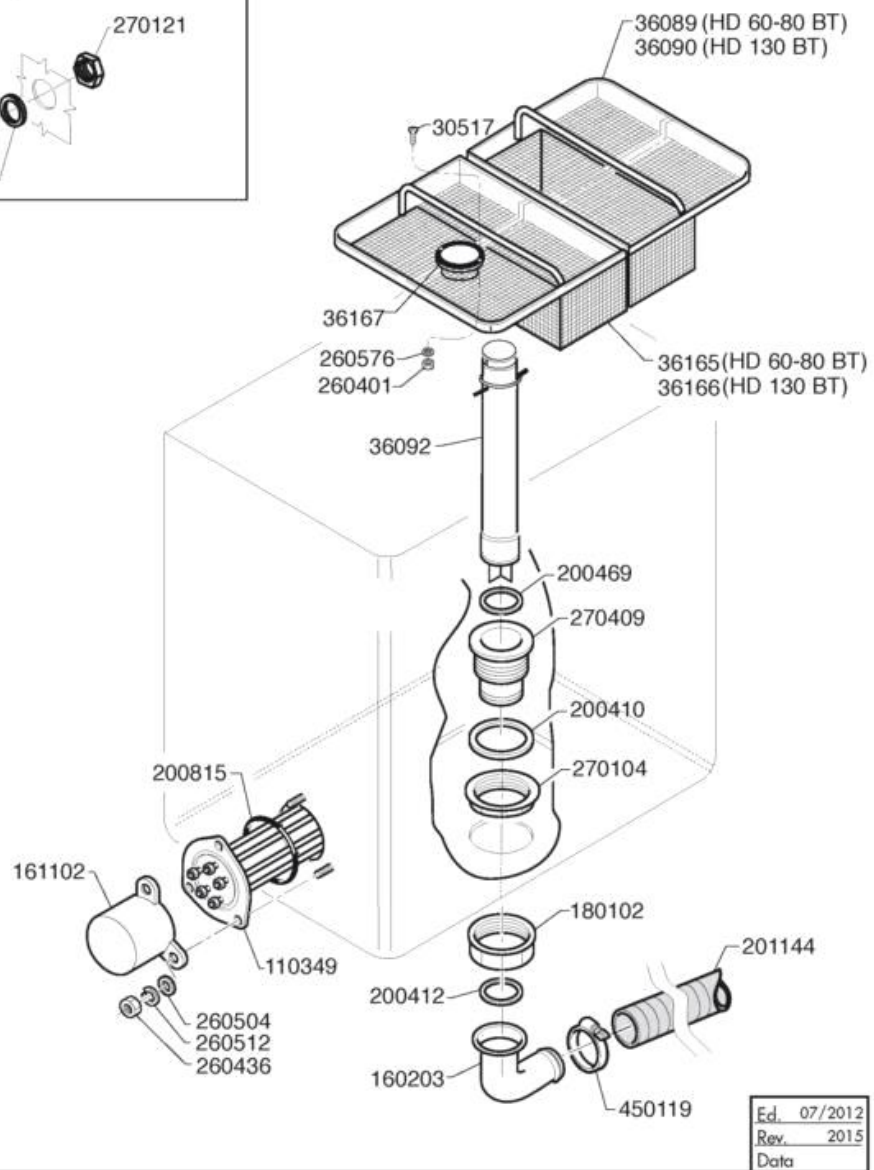
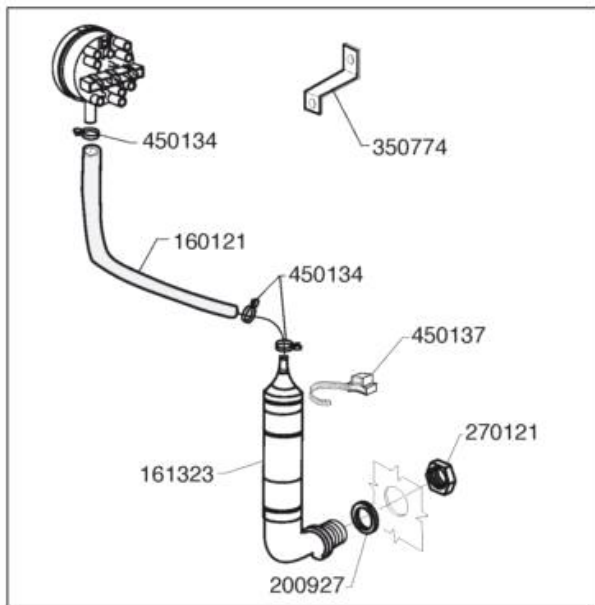

Ed.	07/2012
Rev.	2015
Data	

Code	Description	
110349	RES.FL.6000W.230/400V	
160121	TUBO GOMMA NERA 5X9 PRESSOST.	
160203	CODULO CUR.1"1/2 SCAR.N-S-F-C	
161102	COPRIRESISTENZA H 50 (ALTO)	
161323	TRAPPOLA ARIA ALTA ANNO 2013	
180102	GHIERA 1"1/2 PILETTA F-C75	
200410	GUAR.NEOP.11/2"D.65X47X3	
200412	GUARNIZ. SCARICO 1"1/2 45X33X3	
200469	GUARNIZIONE A LABBRO 45X35.5X7	
200815	GUARNIZIONE OR 6x56x68	
200927	GUARNIZ.TRAPP.PRESS.C95-155	
201144	TUBO DI SCARICO DIAM.33X1500	
260401	DADO STAMPATO 3MA INOX 5587	
260436	DADO 6 MA F/Z	
260504	RONDEL.PIANE D6 INOX UNI 6592	
260512	RONDEL.GROWER D6 INOX UNI 1751	
260576	RONDELLA DENTEL.DIAM.3 D.E.	
270104	CONTRODADO OTT.1"1/2	
270121	CONTRODADO INOX 1/2"GAS TRAP.	
270409	PILETTA SCARICO VASCA 1"1/2	
30517	BEVEL, CROSS-SLOT HD.SCREW TS 3 X 1	
350774	SQUADRETTA PRESSOS.SNLC7595155	
36089	BASKET-FILTER, REAR, EDI 6-8 2?	
36090	BASKET-FILTER, REAR, EDI 13 2?	
36092	OVERFLOW TUBE EDI 2? H=534	
36165	BASKET-FILTER, FRONT, EDI 6-8 2?	
36166	BASKET-FILTER, FRONT, EDI 13 2?	
36167	GUIDE FITTING, OVERFL.TUBE EDI 2?	
450119	FASCETTA FE ZN.58-75 H=12,2	
450134	FASCETTA A FILO X TUB. 9,3-8,8	
450137	ATTACCO A COLLARE C/BASE 31900	



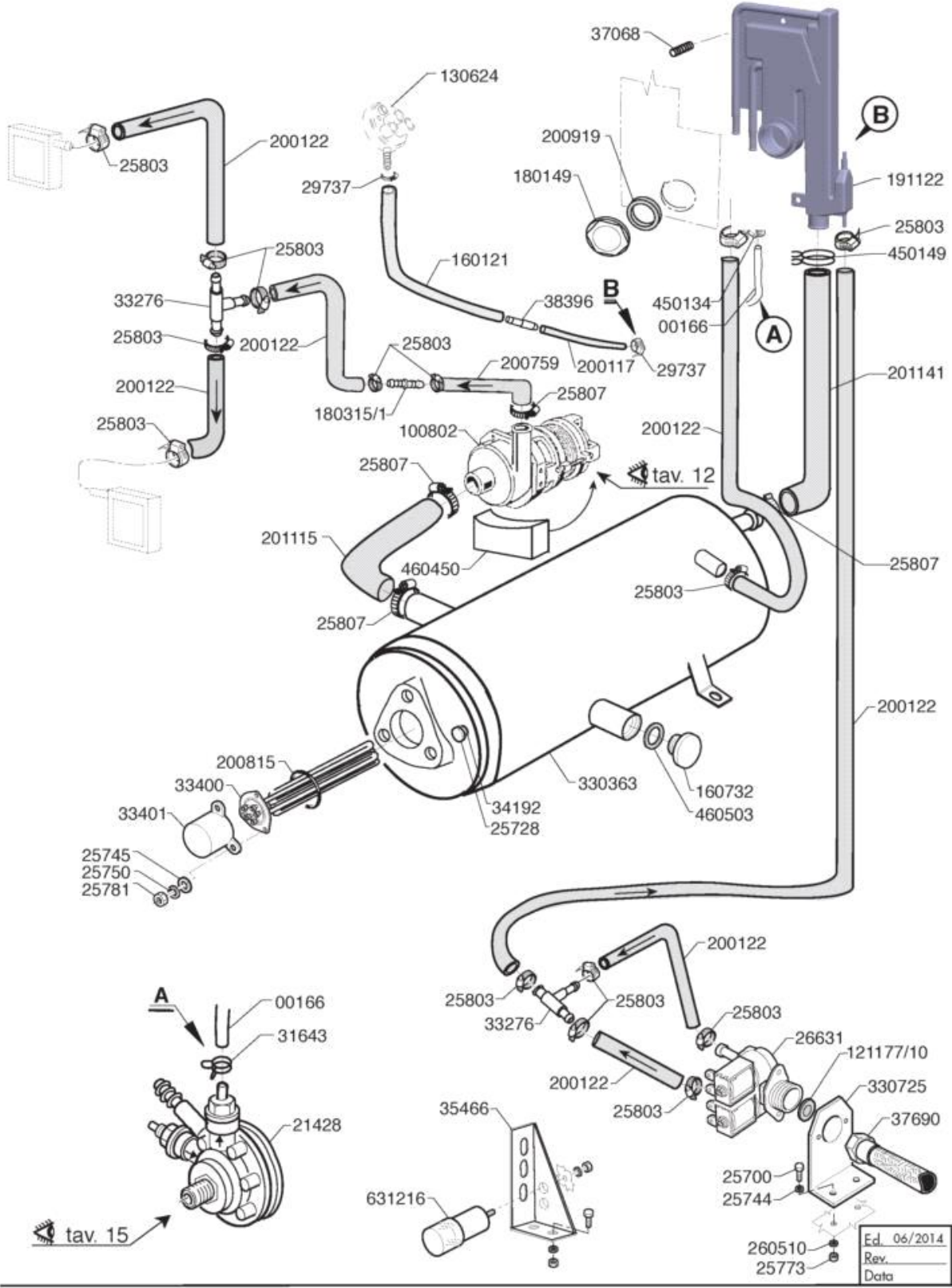

## Rinse Assembly

Code	Description	
00166	ROLL TUBE TRANSP. 4X7	
100802	POMPA kW 0.3 230V/1/50Hz	
121177/10	REG.PORT.USC.5.5L/1'COD.13670	
130624	PRESSOST.1.LIV.110-70	
160121	TUBO GOMMA NERA 5X9 PRESSOST.	
160732	TAPPI NERI C/GUARN.3/4"-GAKT26	
180149	GHIERA x SERB. AIR GAP	
180315/1	CONN.PORTATUBO GN 10 (DIAM.11)	
191122	SERBATOIO BREAK TANK 2011	
200117	TUBO GOMMA 8x15 CALORFORM/10	
200122	TUBO GOMMA 11X19 CASER/15 BLU	
200759	MANICOTTO MAND.P.RISC.	
200815	GUARNIZIONE OR 6x56x68	
200919	GUARNIZIONE x PILETTA ASP.FC	
201115	TUBO ASP.POMPA RISC.HD60/80BT	
201141	TUBO ALIMENT. BOILER HD/BT	
21428	RINSE AID DISPENSER, COMENDA(2-2825	
25700	SCREW CHEESE-H. 4 X 8 KNURLED	
25728	SCREW HEX.HD M 8 X 10 SS	
25744	SPACER, FLAT, DIAM.5	
25745	SPACER, FLAT, DIAM.6	
25750	SPACER, SPLITTED, DIAM. 6	
25773	NUTS 4 MA SS 18/8	
25781	NUTS 6 MA, THREADED/ZINCATED	
25803	HOSE CLIP 13-20 ABA	
25807	HOSE CLIP 26-38 ABA	
260510	RONDEL.GROW.D4 INOX UNI 1751	
26631	SOLENOID V., DOUBLE 3/4"	
29737	FE-ZN CLAMP 9 - 12	
31643	HOSE CLIP 7,3-7,8	
330363	BOILER BREAK TANK MAGGIORATO	
330725	SQUADRETTA UNIFICATA	
33276	T-SHAPED CONNECTOR ?11,5-PART180413	
33400	HEAT.EL.FL.6000W 220/380V (110349)	
33401	COVER, HEATING ELEMENT H 50 (HIGH)	
34192	SEAL WASHER	
35466	PLATE PUMP 60 BT	
37068	PRIGIONIERO FILETTATO 5X25	
37690	TUBO CARICO INOX 3/4" Wras	
38396	RACCORDO DRITTO A PORTAGOMMA	
450134	FASCETTA A FILO X TUB. 9,3-8,8	
450149	FASCETTA A 2 FILI D.34.6x36.4	
460450	DISTANZIALE x BOILER d.150	
460503	GUARNIZ.38X27X2 3/4 FASIT OM.	
631216	CONDENSATORE 6,3 mF.450V	

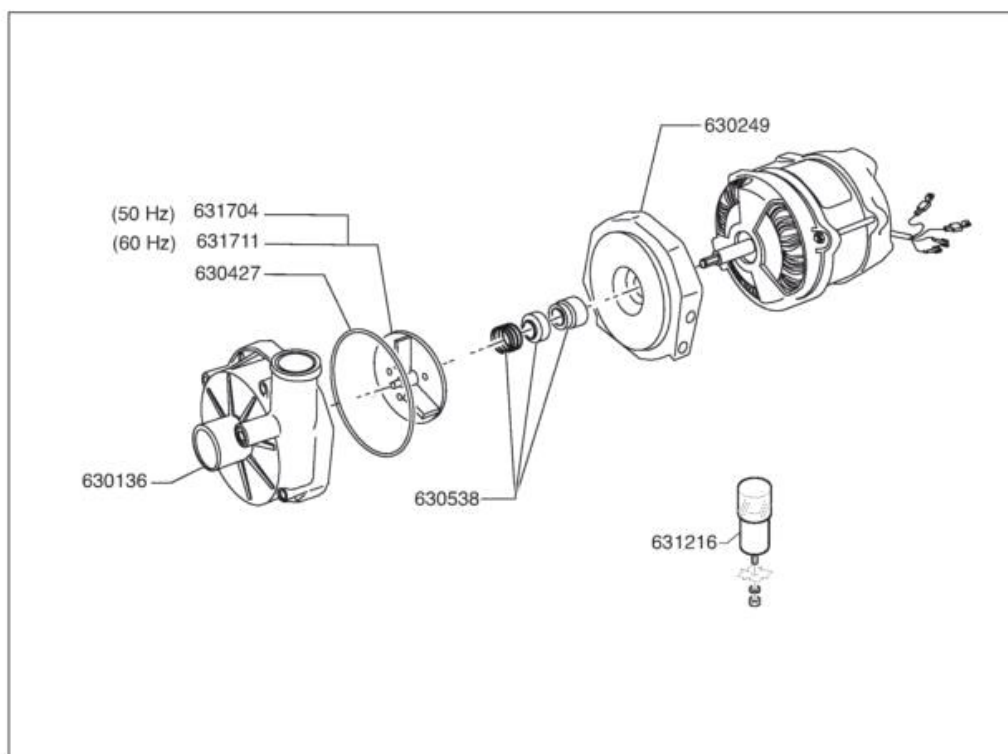
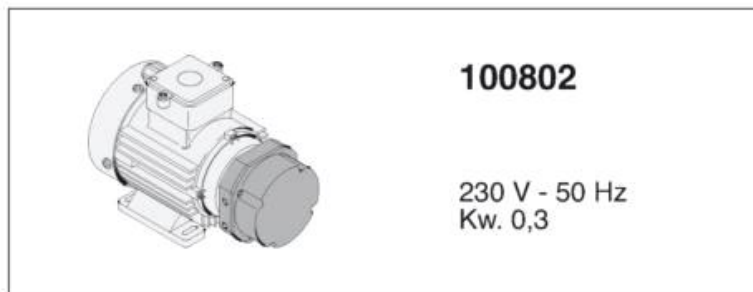

Ed.	07/2012
Rev.	
Data	

## Rinse Pump

Code	Description	
100802	POMPA kW 0.3 230V/1/50Hz	
630427	GUARNIZIONE OR X POMPA ZF131DX	
630538	TENUT.POMP.LGBZF131DX GIR.INOX	
631216	CONDENSATORE 6,3 mF.450V	

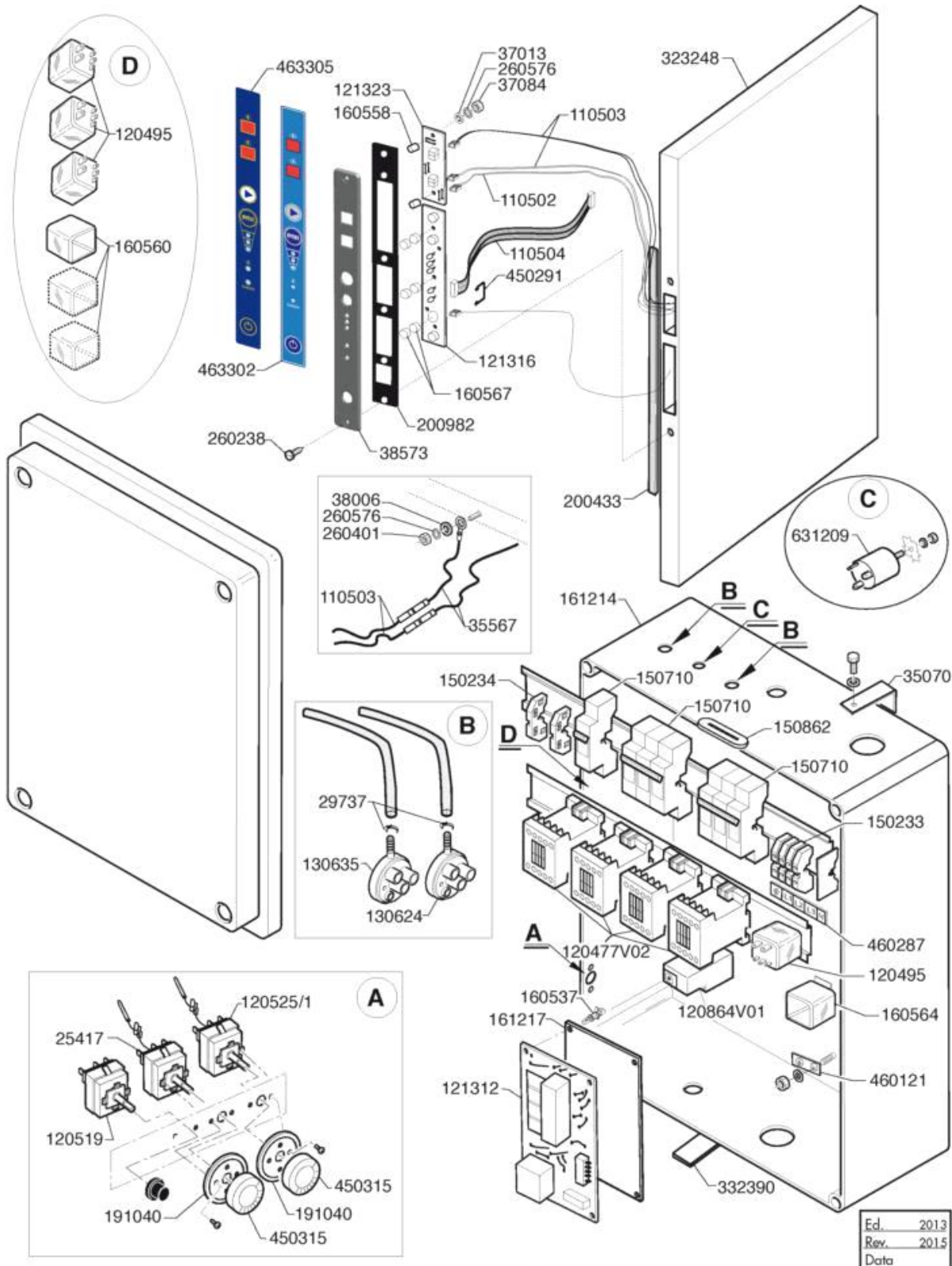

Code	Description	
110502	FILI CONN.MOD2 x TASTeTERM.2mt	
110503	FILI CONN.MOD2 x SONDE 2mt.	
110504	CAVO COLLEG. 2500 mm. 10 POLI	
120477V02	CONTAT.ABB AF09 9A230VAC-30-01	
120495	RELE' TIPO 62.82 16A 250V.	
120519	TERMOSTATO 110/130?SIC.LS1 F-C	
120525/1	TERMOSTATO 2 TEMP. S&RIND	
120864V01	RELE TERM. ABB TF42 4,2-5,7A	
121312	SCHEDA ELETTR. HD/GE ANNO2010	
121316	PULSANT.4TASTI RETROIL.LED BLU	
121323	SCHEDA TERM.VERTICALE SERIE HD	
130624	PRESSOST.1.LIV.110-70	
130635	PRESSOSTATO TAR. 190/40	
150233	MORS.TRIP.16MMQ 8WA1304	
150234	MORS.UNIP.16MMQ 8WA1204	
150862	GUAINA PASS.FLAT CABLE (36807)	
160537	DISTANZ. x SCHEDE ELETTRONICHE	
160558	DISTANZ.BASSO PER SCH.TERMOM.	
160560	SUPPORTO RELE FIND. 062.07 DIN	
160564	SUPPORTO RELE FIND. 062.08 DIN	
160567	DISTANZIALE H3 TIPO RRSN-52100	
161214	CASS.EL.IP56 GEWISS GW44211	
161217	PROTEZ.TIMER ELETTR.SOFT START	
191040	MASCHERINA MANOPOLA TERMOSTATI	
200433	GOMMA SPUGNA ADES.6x2,5 NEOPR	
200982	GUARN.GOMMA SUPPOR.TARGA HD BT	
25417	THERMOSTAT 30-90? MT. 2	
260238	VITE INOX "TB" 4x10	
260401	DADO STAMPATO 3MA INOX 5587	
260576	RONDELLA DENTEL.DIAM.3 D.E.	
29737	FE-ZN CLAMP 9 - 12	
323248	PANNELL.COM.LAT.DX HD60/80/130	
332390	SQUADRETTA SUPP.IMPIANTO GE	
35070	BRACKET, RINSE AID DISPENSER EDI	
35567	PROBE TEMP. NTC 3.3K YELLOW	
37013	RONDELLA PIANA M3 003030500001	
37084	DADO NYLON M3	
38006	RONDELLA PIANA M4x12 DIN9021A2	
38573	SUPPORTO TARGA COM.HD con PRIG	
450291	MOLLA BLOCC.CAVO SCHEDA H37332	
450315	MANOPOLA TERMOSTATI	
460121	TARGH.DI MESSA A TERRA= 33349	
460287	TARGHETTA X MORSETT.MONOFASE	
463302	TARGA COMANDI SERIE HD BT	
463305	TARGA COMANDI SERIE LB BT	

Code	Description	
631209	FILTRO ANTIDISTURBO TIPO 5001	

21428

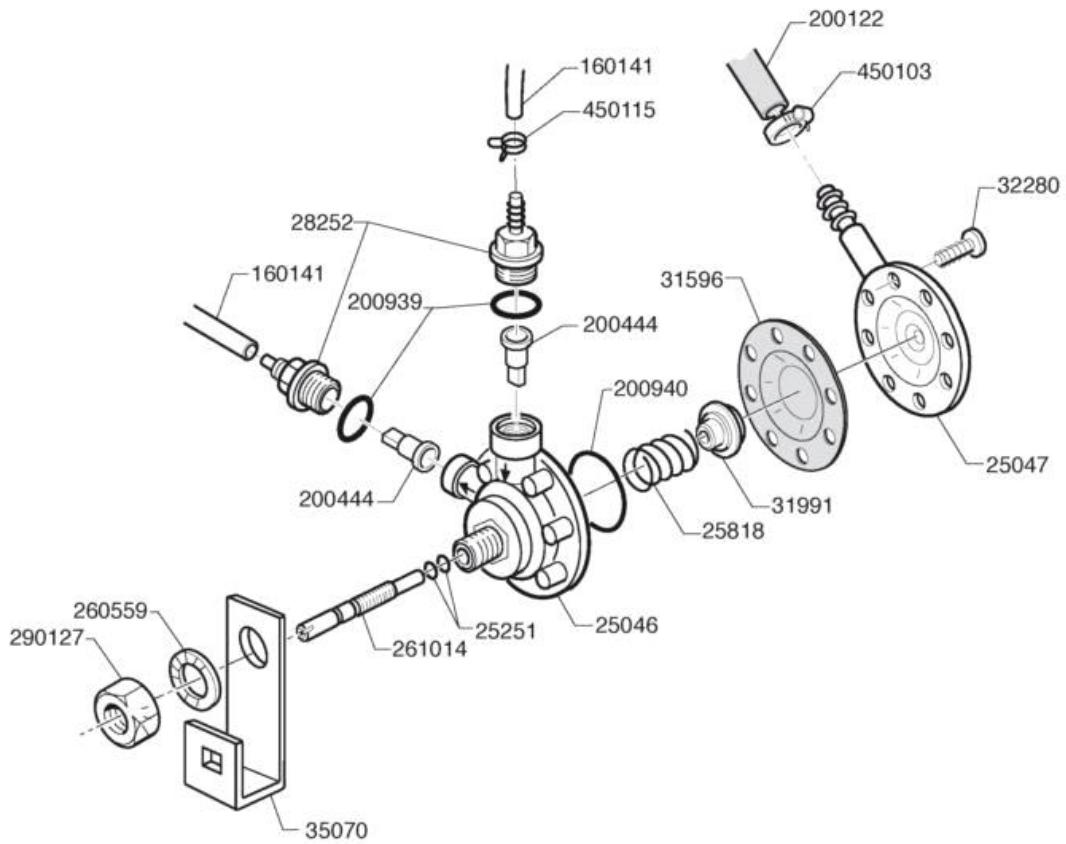
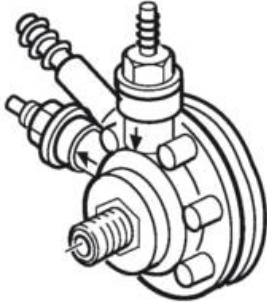

Ed.	07/2012
Rev.	2015
Data	



## Rinse Aid Injector

Code	Description	
160141	TUBETTO TRASP. BLU 4X7 ROTOLO	
200122	TUBO GOMMA 11X19 CASER/15 BLU	
200444	VALVOLA ASP.DOSATORE SILICONE	
200939	OR RACC.MAND/ASP.DOS.	
21428	RINSE AID DISPENSER, COMENDA(2-2825	
25046	UPPER DISPENSER ASSEMBLY	
25047	LOWER DISPENSER ASSEMBLY	
25251	GASKET OR 2012	
25818	CYLINDER SPRING (WIRE)	
260559	ROND.DENT.INOX A2D.12 DIN6798	
261014	VITE REGOLAZIONE DOS.BRILL.HVD	
28252	FITTING SUCTION DISPENSER	
290127	DADO FISS. DOSATORE	
31596	DIAPHRAGM, DISPENSER	
31991	SPRING GUIDE FOR DISPENSER	
32280	OVAL HD. CROSS-SL. SCREW 4 X 13	
35070	BRACKET, RINSE AID DISPENSER EDI	
450103	FASCETTA FE ZN.13-20 H=9	
450115	FASCETTA A DUE FILI D.8,3/7,8	

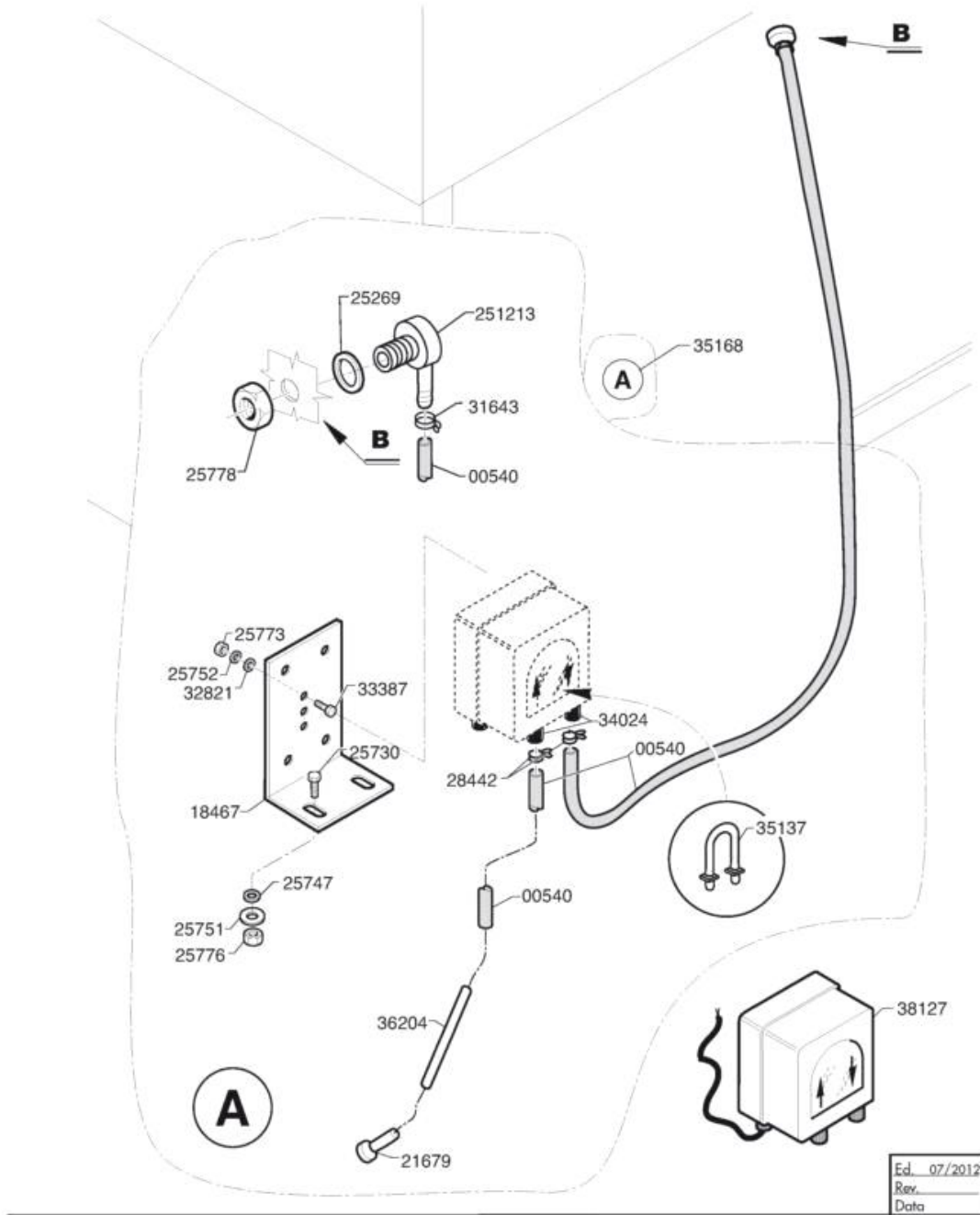

## Detergent Pump

Code	Description	
00540	RED TUBE 8X4 ROLL	
18467	HOLDING SUPP. PUMP DISPENS.	
21679	FILTER DET.-RINSE AID PREASS.	
251213	PORTAG.A GOMITO INOX POMPA DET	
25269	FLAT GASKET	
25730	SCREW HEX.HD M 8 X 25	
25747	SPACER, FLAT, DIAM. 8	
25751	SPACER. SPLITTED, DIAM. 8	
25752	TOOTHED SPACER DIAM.4 D.E.	
25773	NUTS 4 MA SS 18/8	
25776	NUTS 8 MA SS 18/8	
25778	NUTS 12 M 18/8 ss	
28442	WIRE CLIP	
31643	HOSE CLIP 7,3-7,8	
32821	FLAT WASHER DIAM 5,5/15	
33387	HEX.HD SCREW 4X16 SS A2 UNI 5739	
34024	PIPE UNION 4X6 X LIQ/FLU VS5562	
35137	PUMP HOSE DET.SEKO PG3	
35168	ACCESSOR.KIT, DETERG.PUMP, EDI	
36204	SINGLE COUNTERWEIGHT, DETERGENT HOS	
38127	POMPA PERISTALTICA SEKO PR 7	

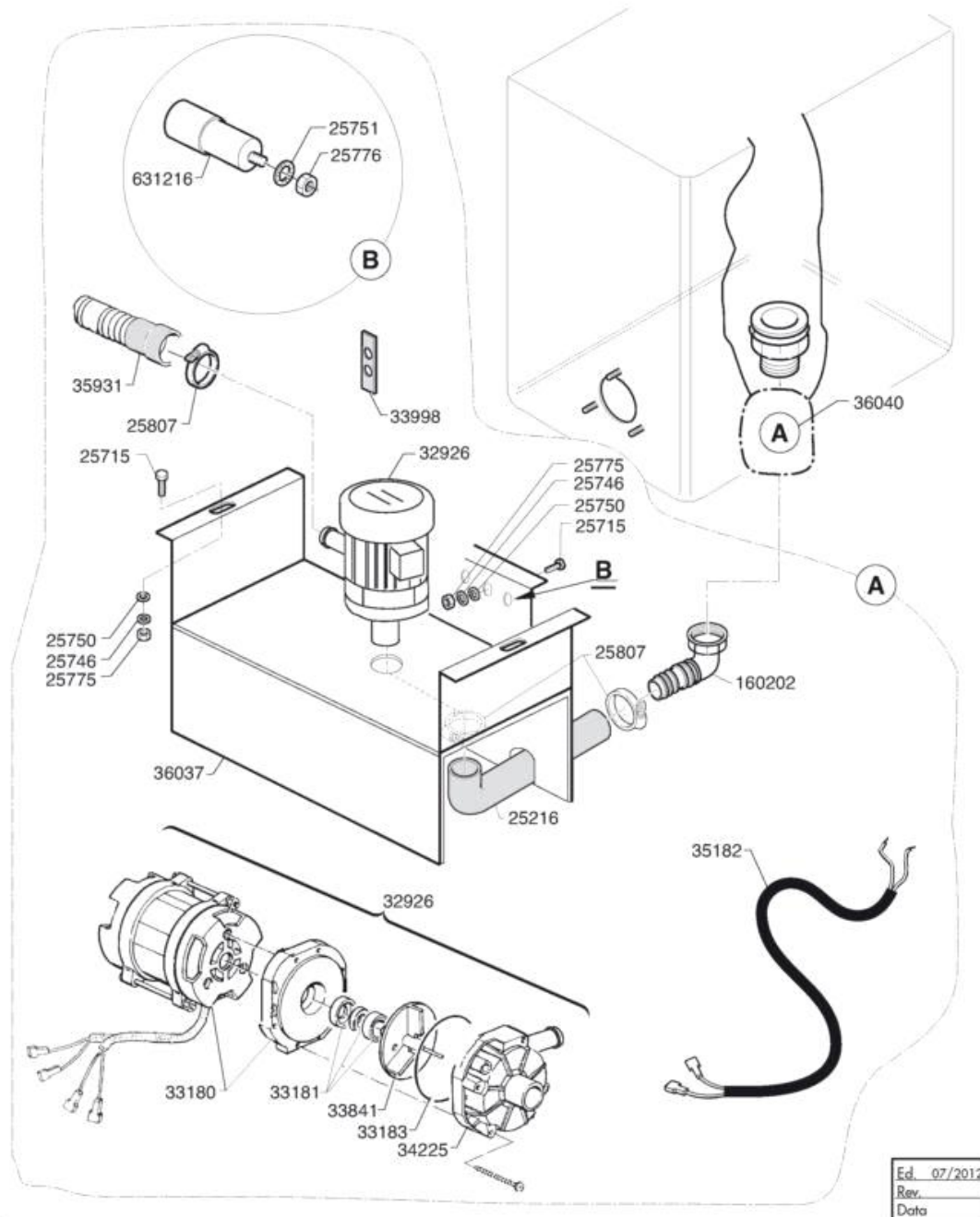

## Drain Pump

Code	Description	
160202	COD.CURVO 2 PRESE PIL.107868	
25216	DRAIN SLEEVE 50-52-T4(T5)	
25715	SCREW HEX.HD M 6 X 16 SS	
25746	SPACER, FLAT, DIAM.6/18	
25750	SPACER, SPLITTED, DIAM. 6	
25751	SPACER. SPLITTED, DIAM. 8	
25775	NUT 6 MA	
25776	NUTS 8 MA SS 18/8	
25807	HOSE CLIP 26-38 ABA	
32926	DRAIN WASH PUMP HP0,15 50/60 HZ	
33180	PUMP BODY (32926) LGB	
33181	SHAFT SEAL C3 (LGB)FOR PUMP CODE 32	
33183	GASKET OR 75,87X2,62 LGB	
33841	IMPELLER DIAM.73, 3-BLADE, M7SX	
33998	VIBR.PROOF RUBBER GASK. FOR PUMP	
34225	PUMP COVER 2212303/HO	
35182	CABLE LOOM, DRAIN PUMP EDI	
35931	DRAIN PIPE, DIA.24X2500	
36037	SUPP.PLATE, DRAIN PUMP EDI 2?	
36040	KIT: DRAIN PUMP EDI 6/8/13 2?	
631216	CONDENSATORE 6,3 mF.450V	