









PARTI DI RICAMBIO
PIECES DETACHEES
SPARE PARTS
ERSATZTEILE
LISTA DE RECAMBIOS



07/99

- | | |
|--|---------------|
|  | HN 302 |
|  | HN 402 |
|  | HN 502 |
|  | HN 552 |
|  | HN 702 |
|  | HN 752 |
|  | HN 902 |
|  | HN 952 |

01 - 2000 S. AG.

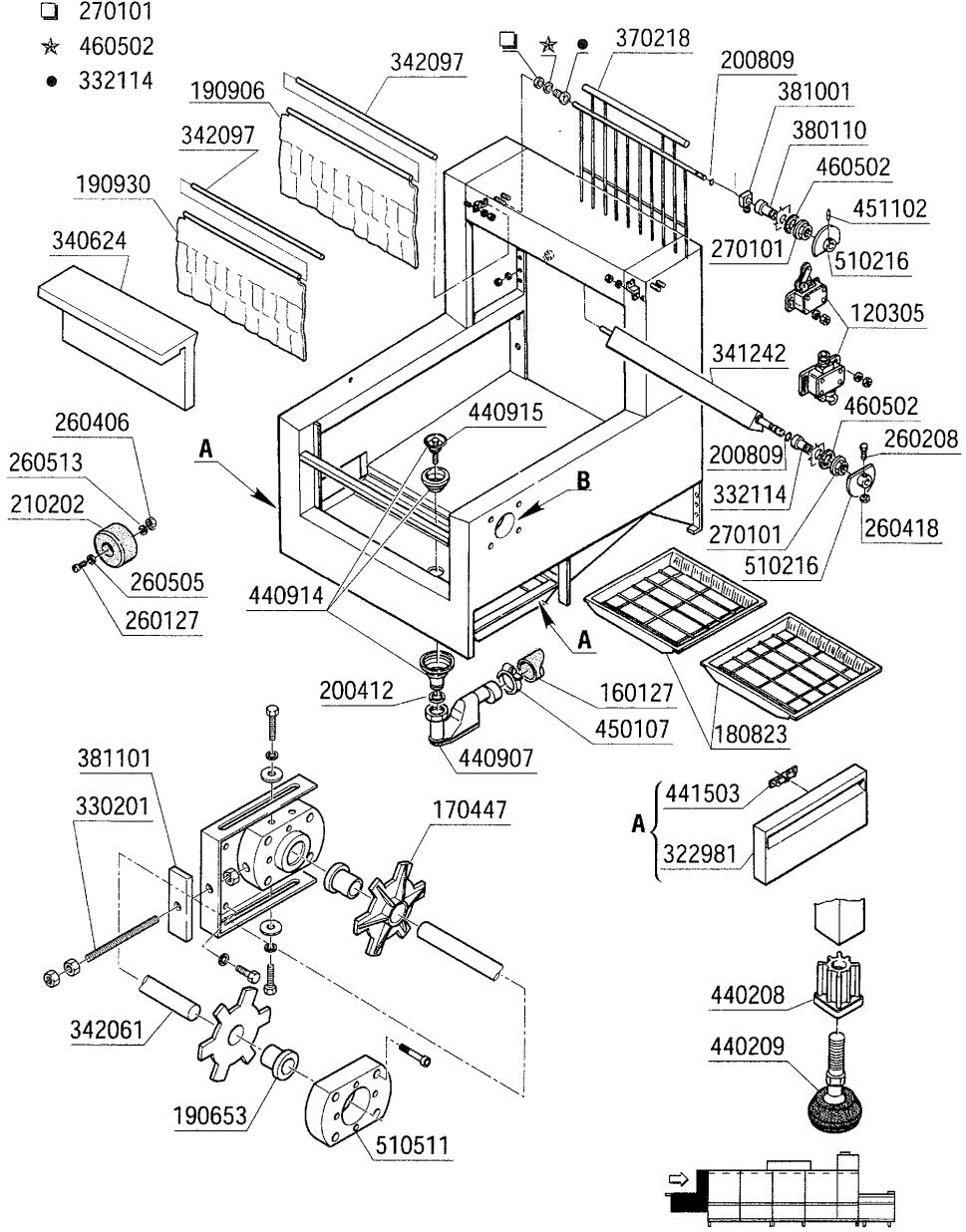

NOTE: _____

REV. 01
07/2000 - S.A.G.

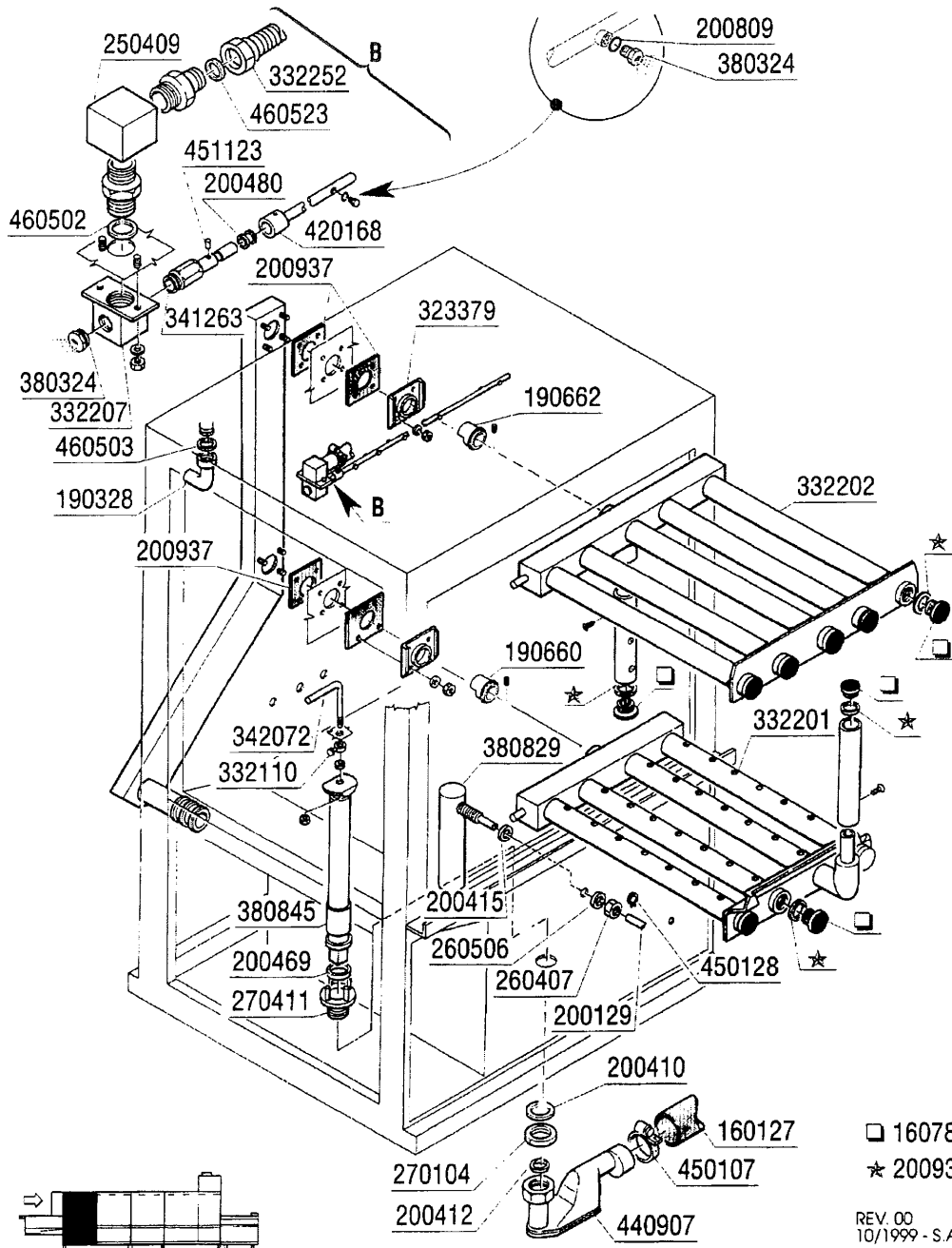

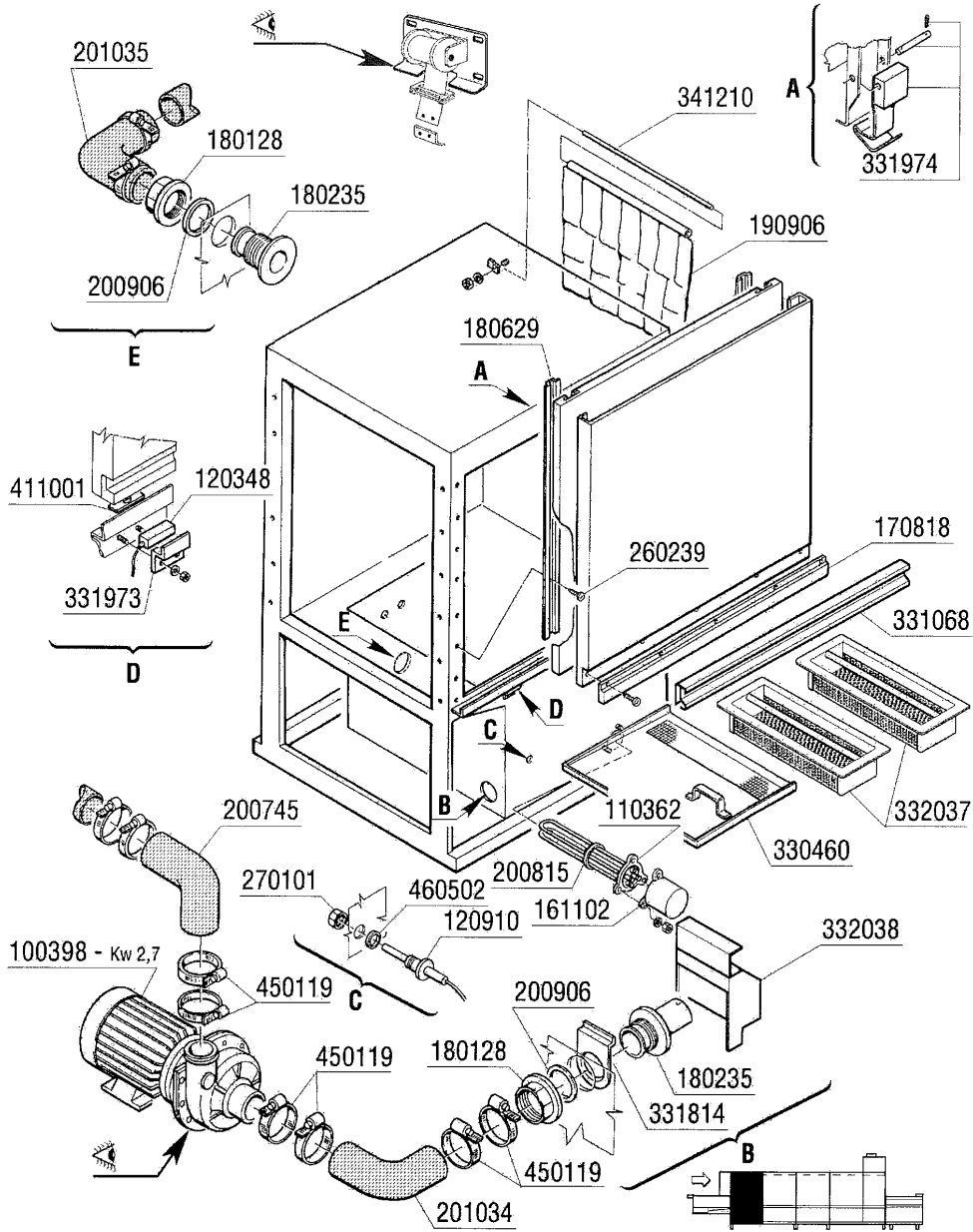

NOTE: _____
 REV. 01
 06/2001 - S.A.G.

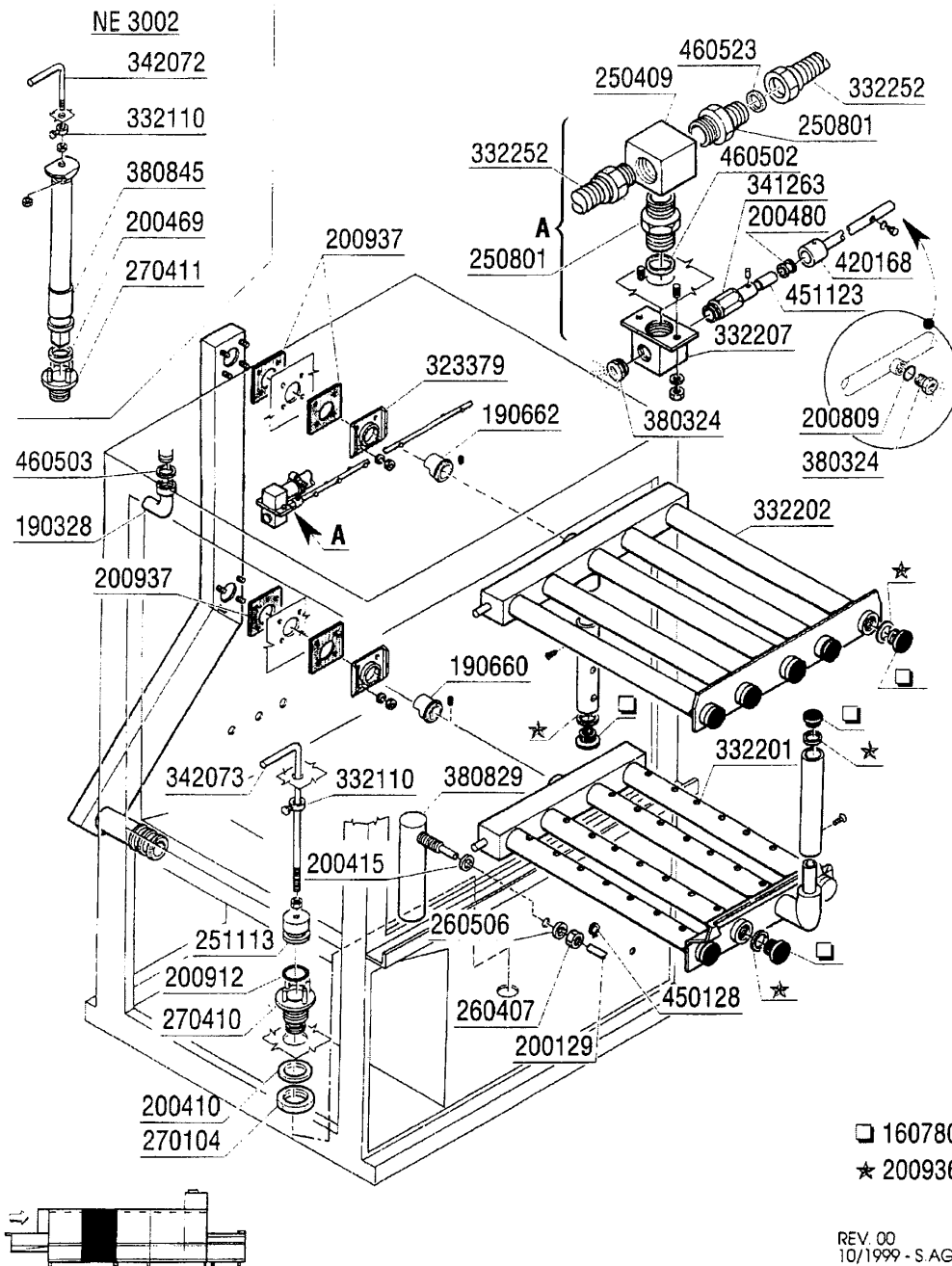

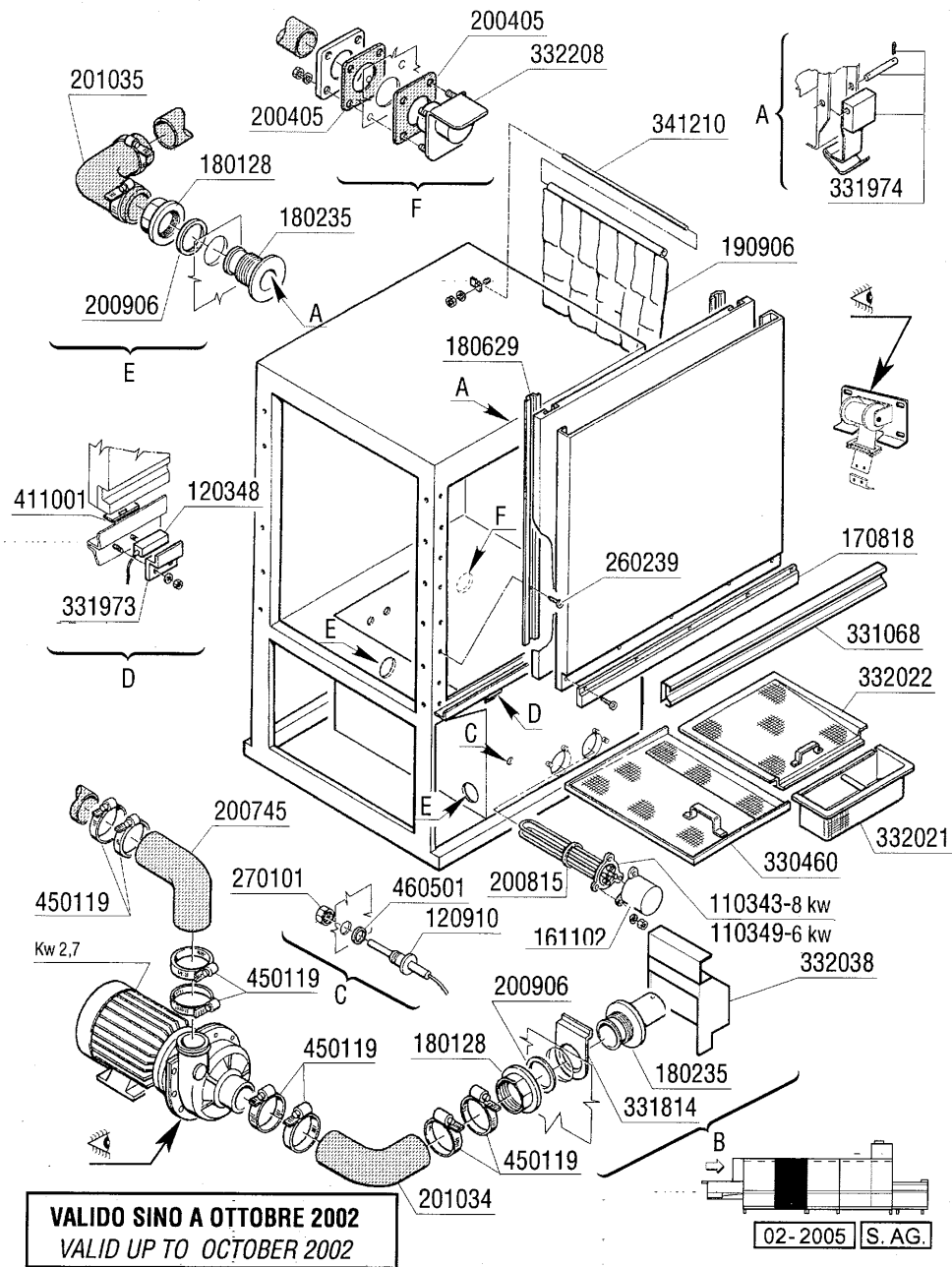

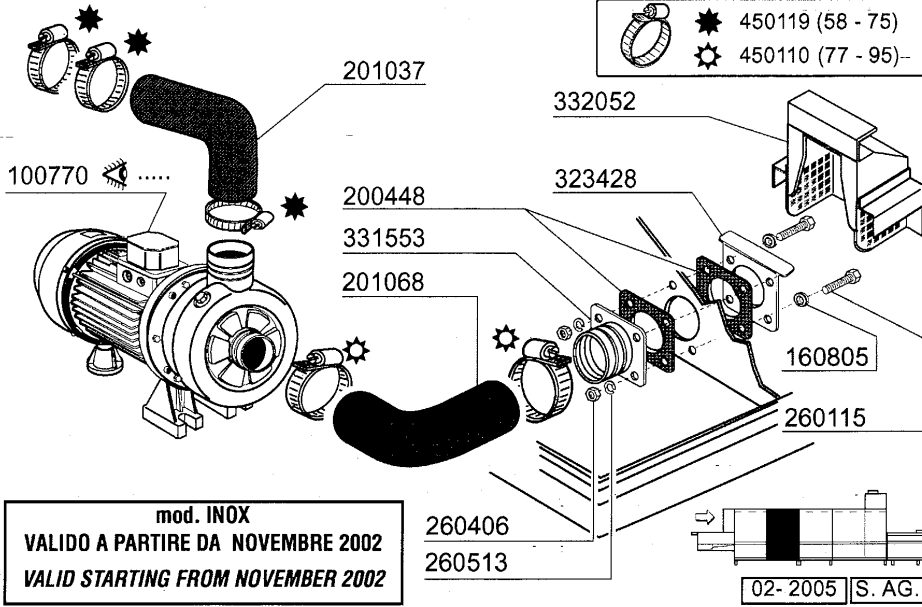
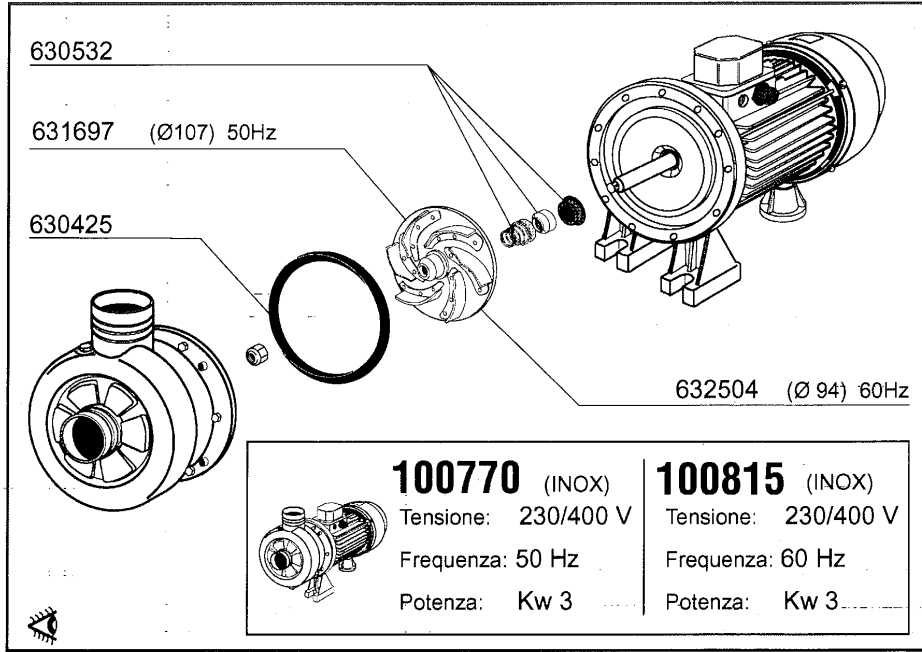

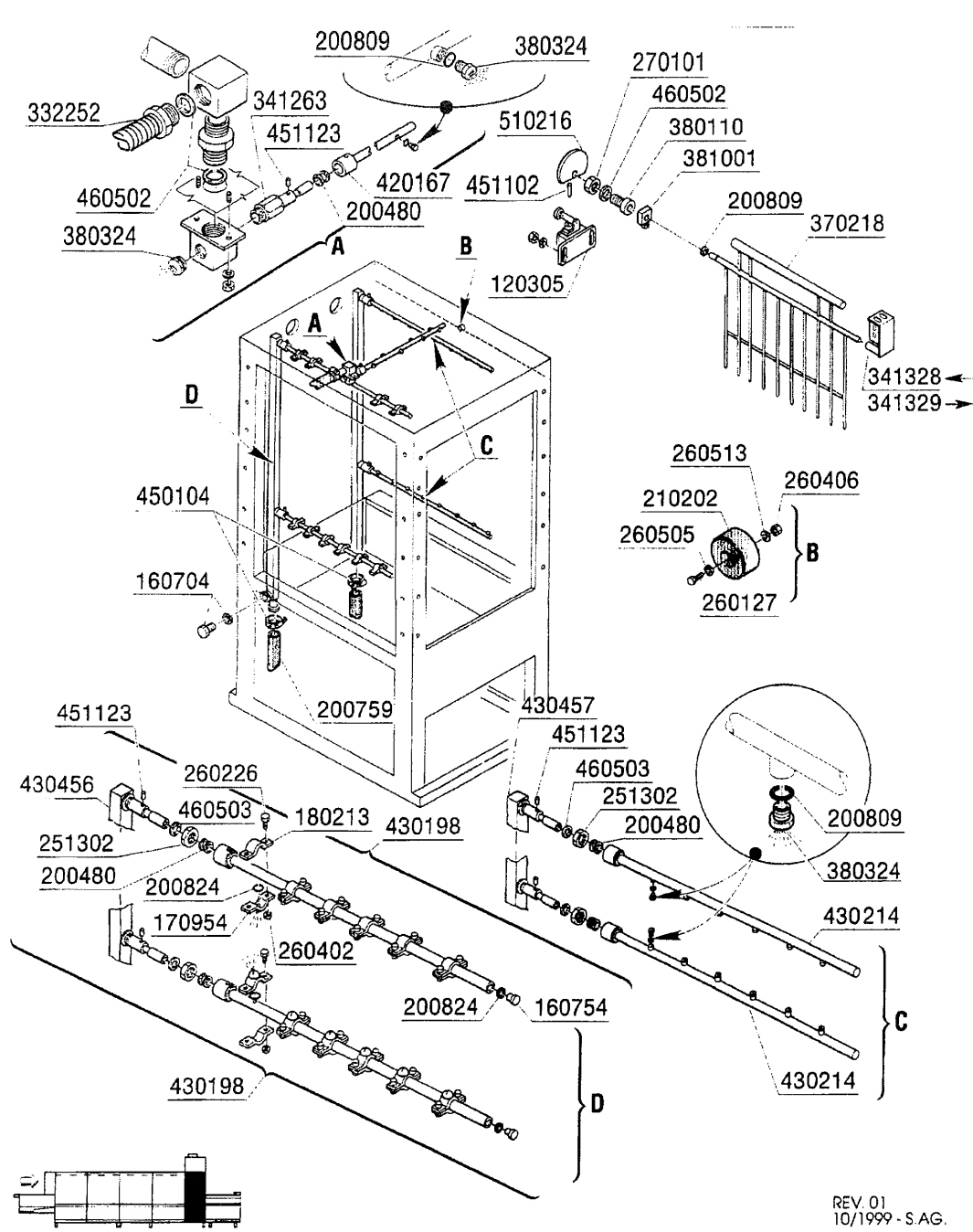

REV. 01
10/1999 - S.AG.

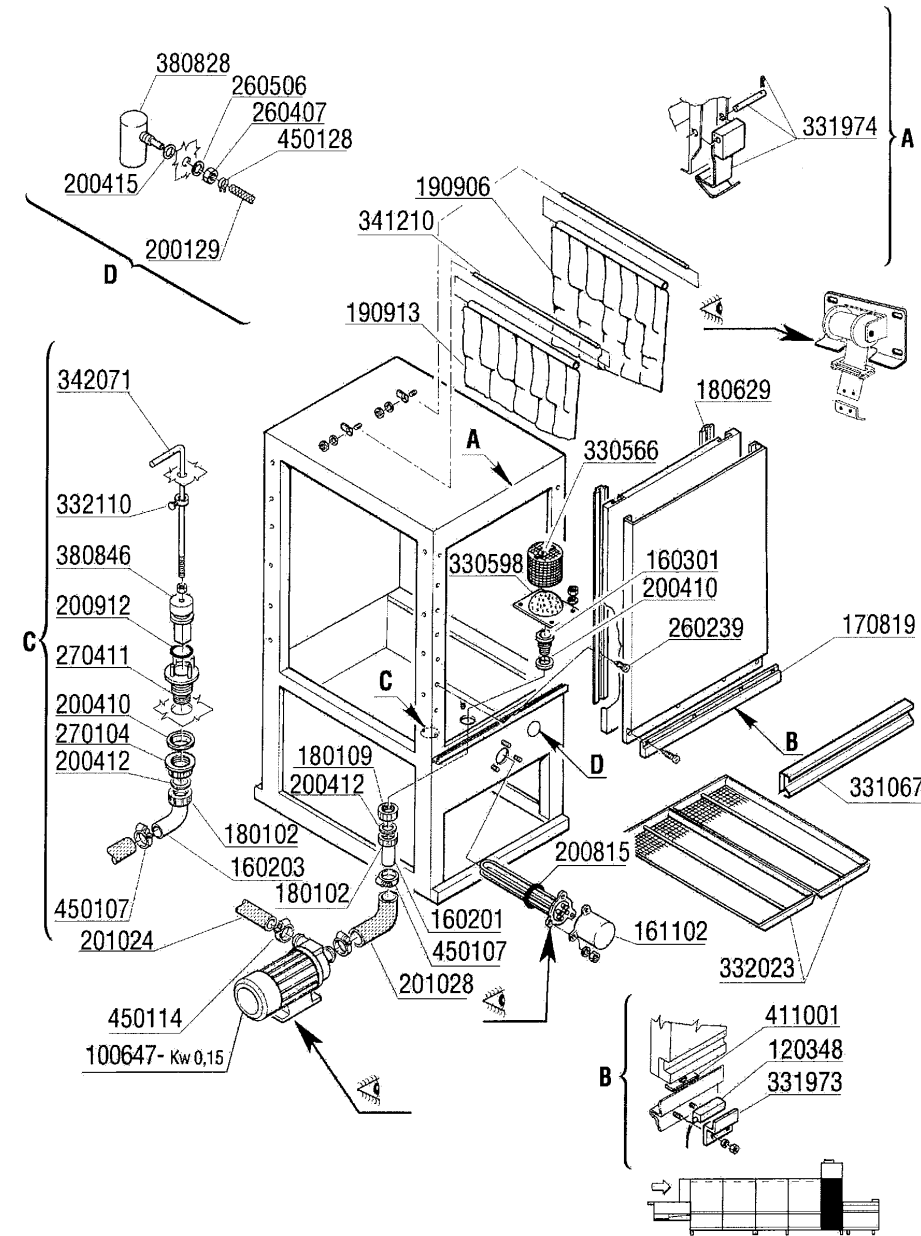

NOTE: _____	REV. 01 06/2001 - S.A.G.
-------------	-----------------------------

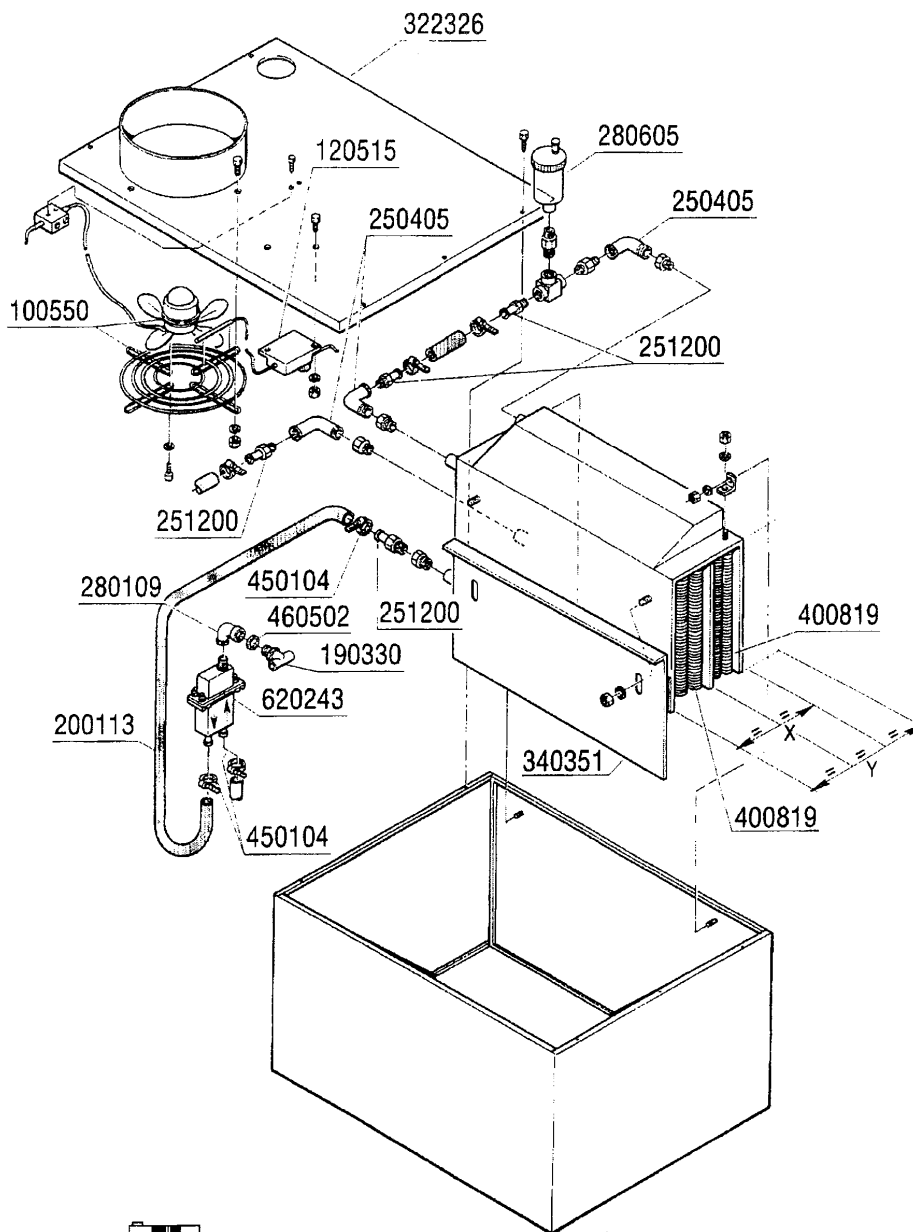

REV. 00
10/1999 - S.A.G.

X= 370 mm = 40 mq = 2x400819
Y= 555 mm = 60 mq = 3x400819

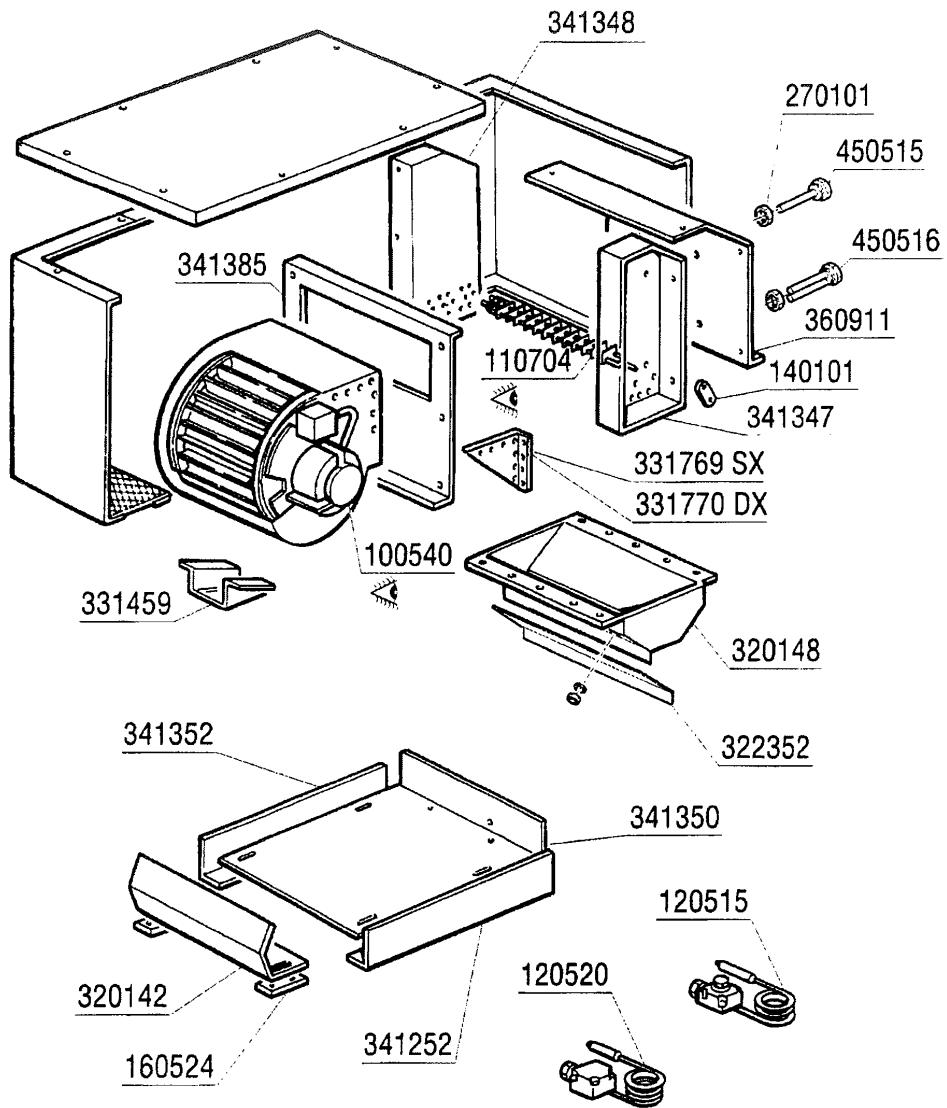

REV. 00
 10/1999 - S.A.G.



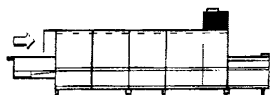
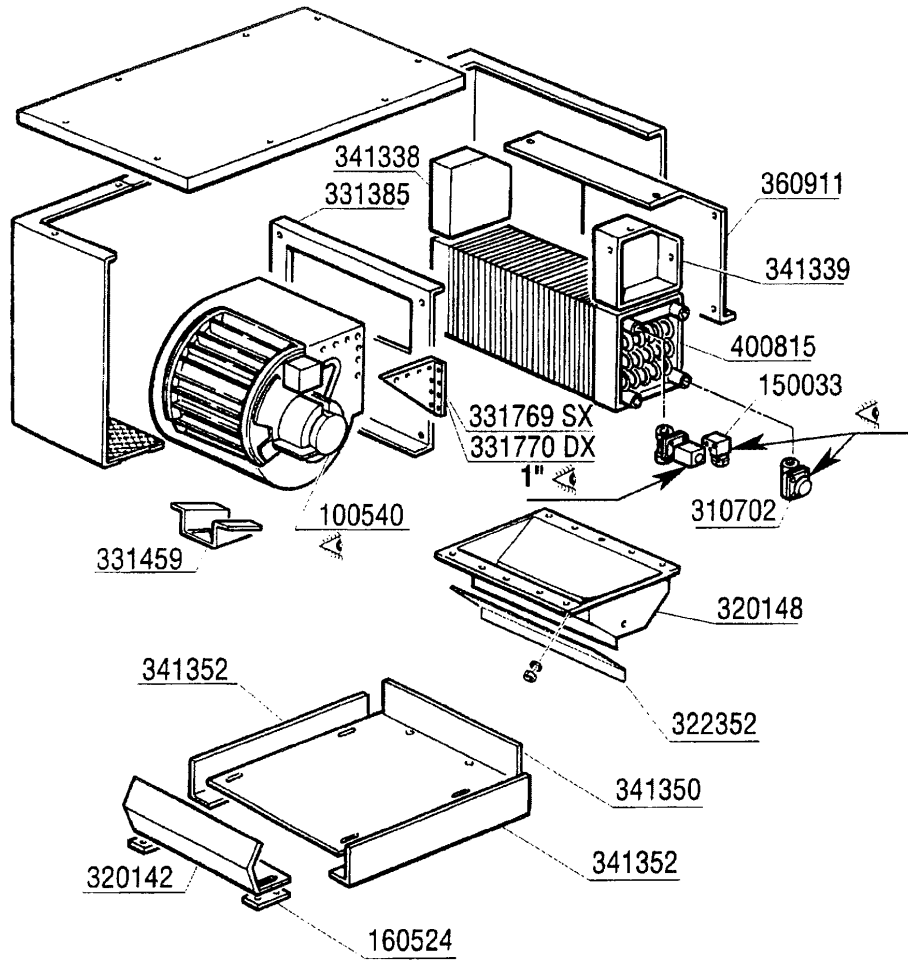

REV. 00
10/1999 - S.A.G.

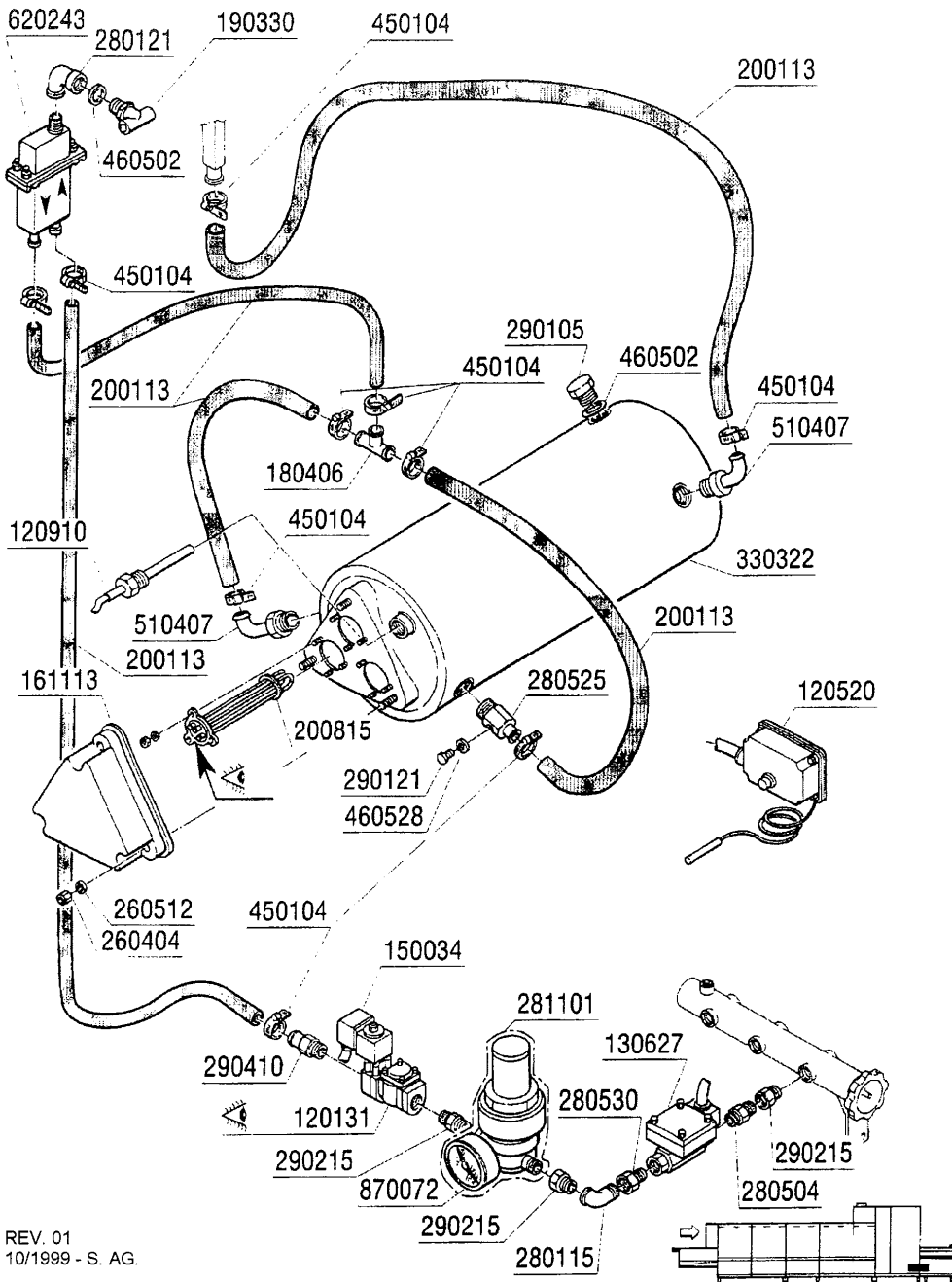

REV. 01
 10/1999 - S. AG.

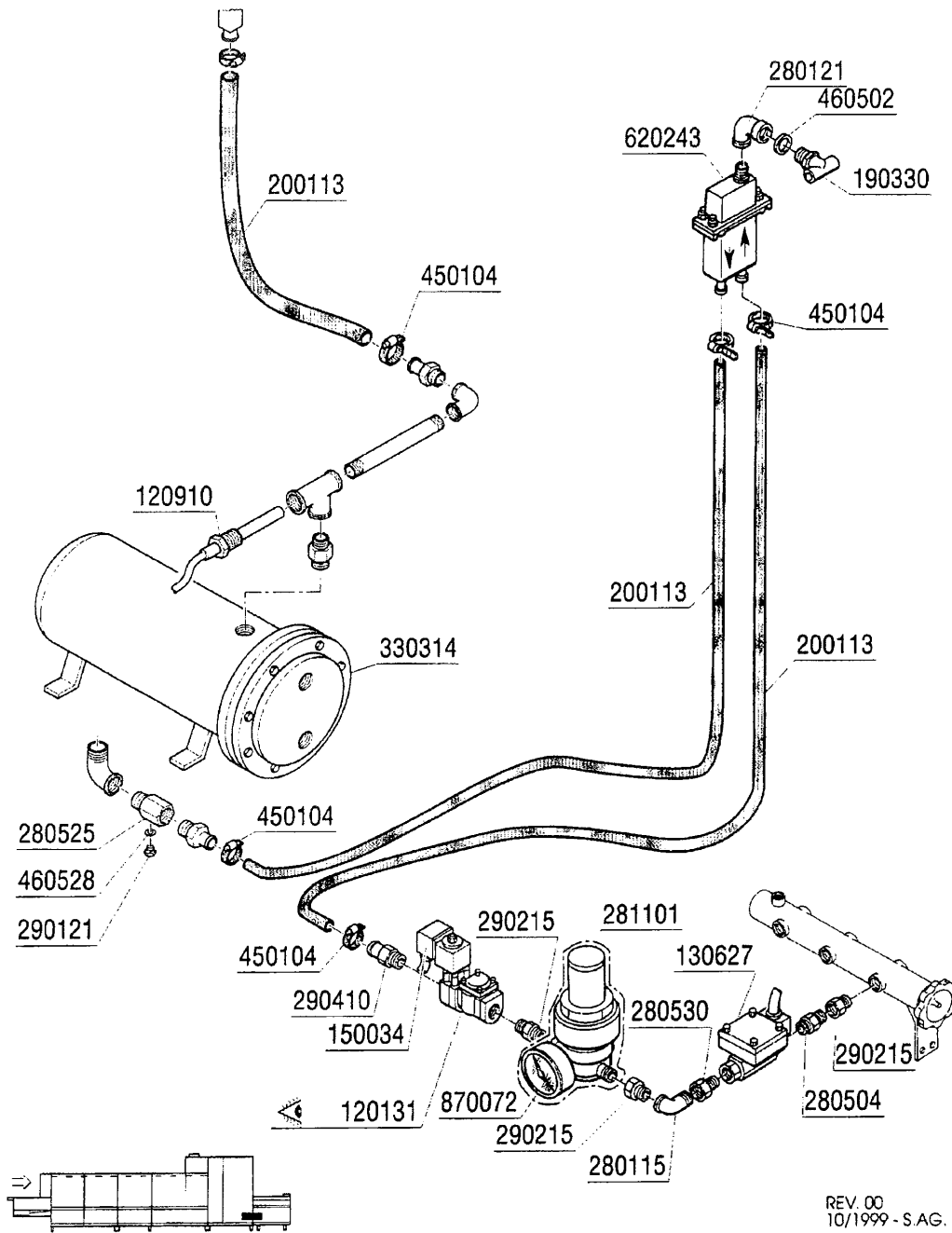

REV. 00
 10/1999 - S.AG.

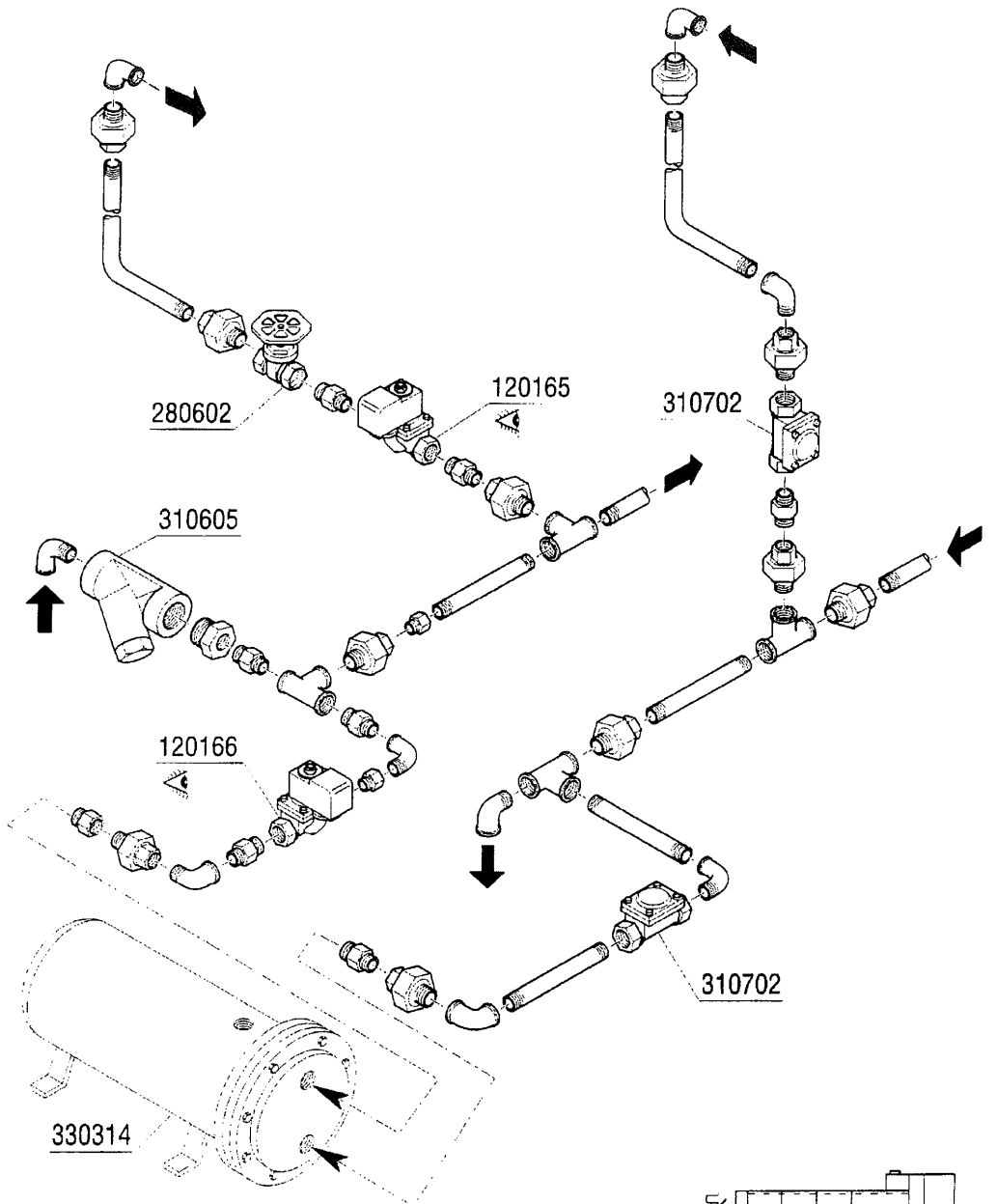

REV. 00
 10/1999 - S.A.G.

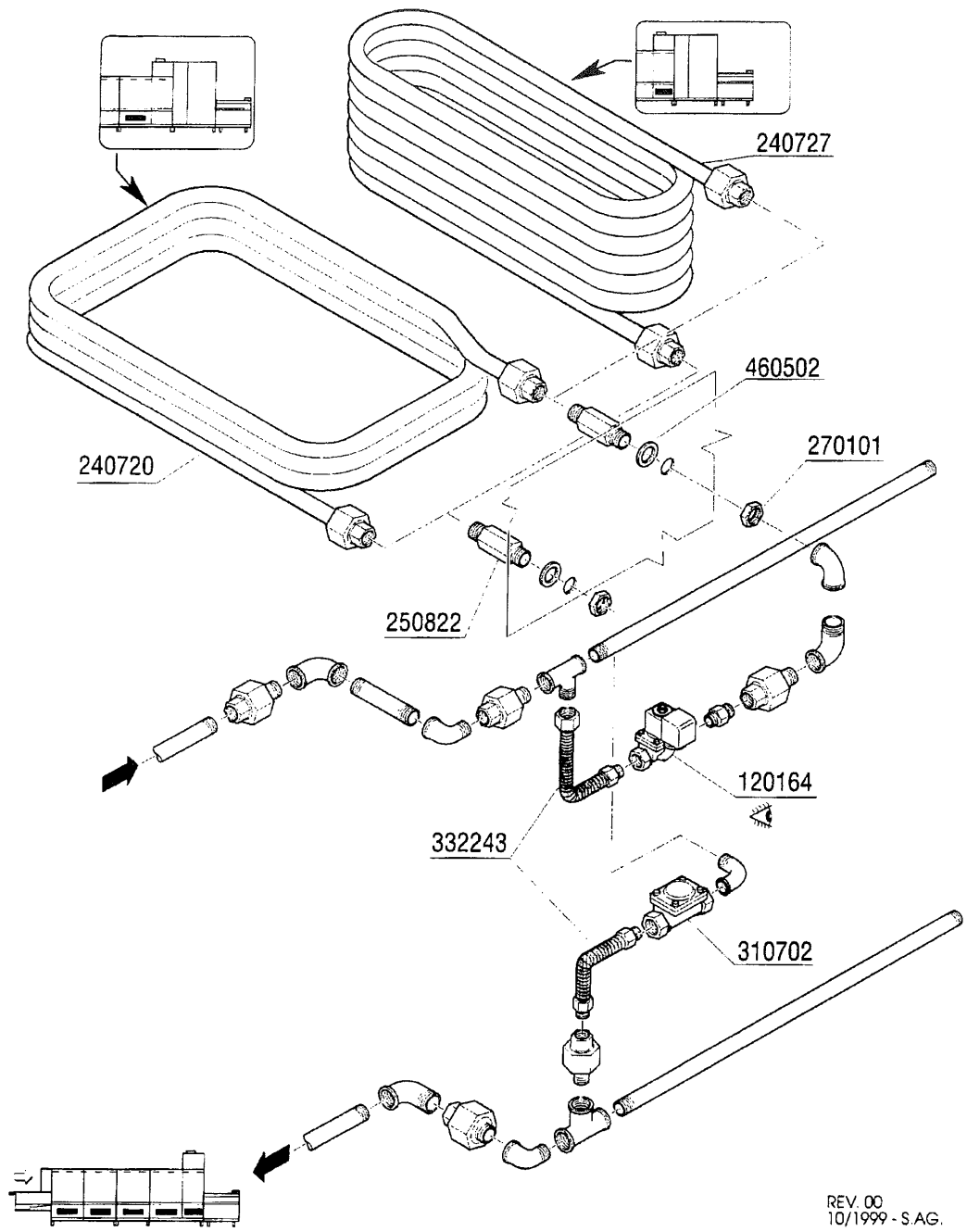

REV. 00
10/1999 - S.AG.

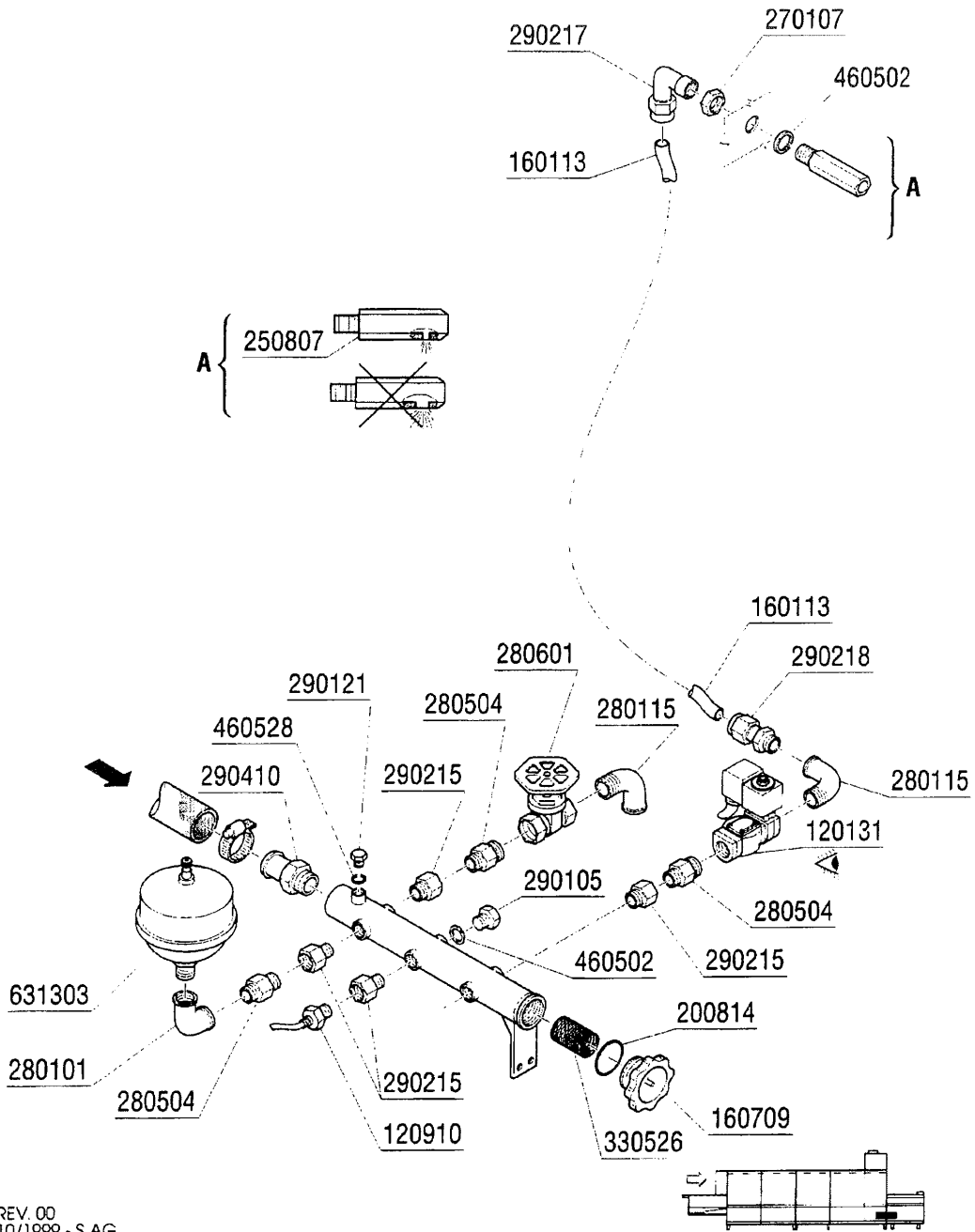

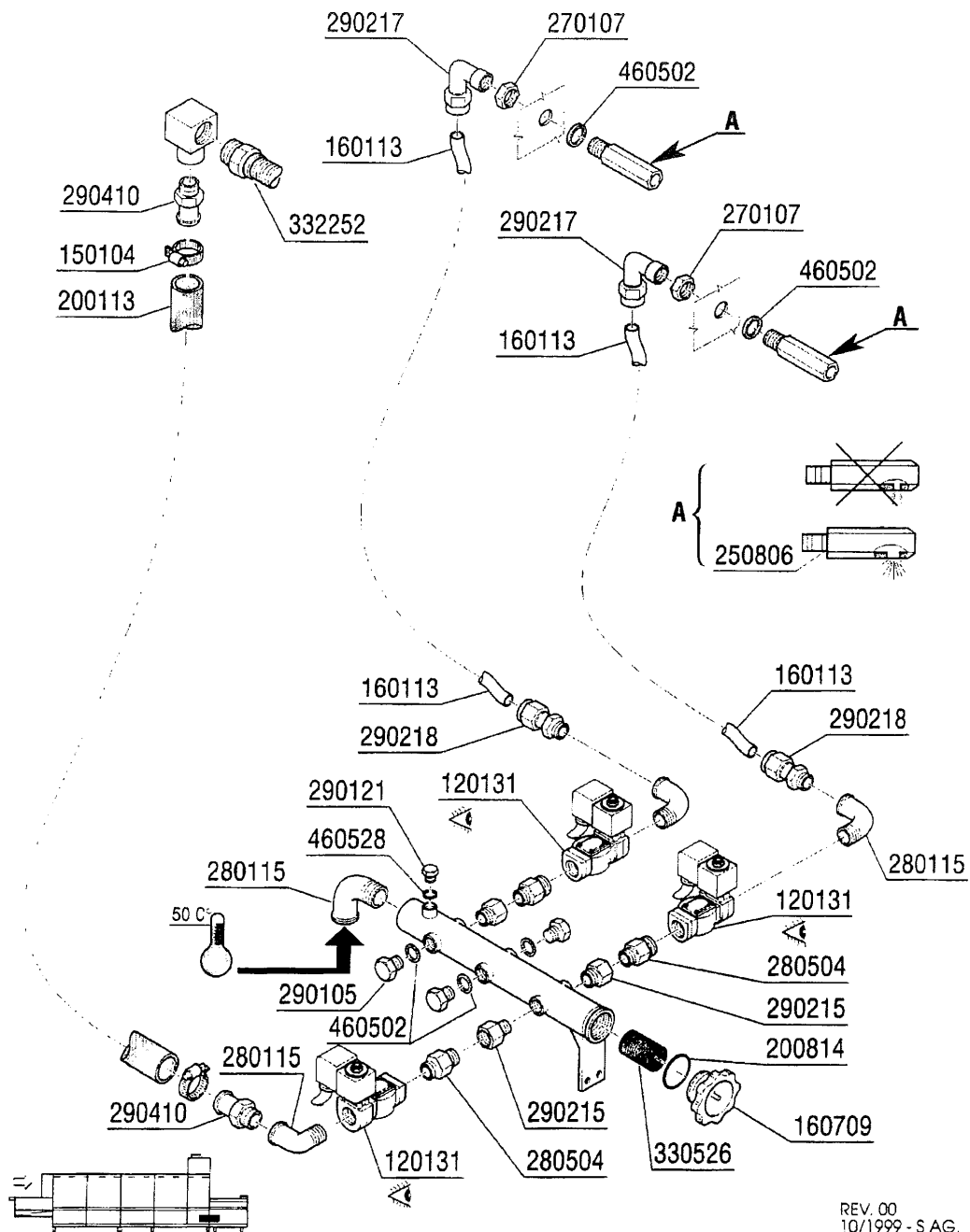

REV. 00
 10/1999 - S.A.G.

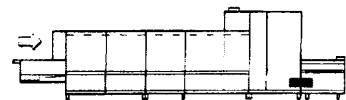
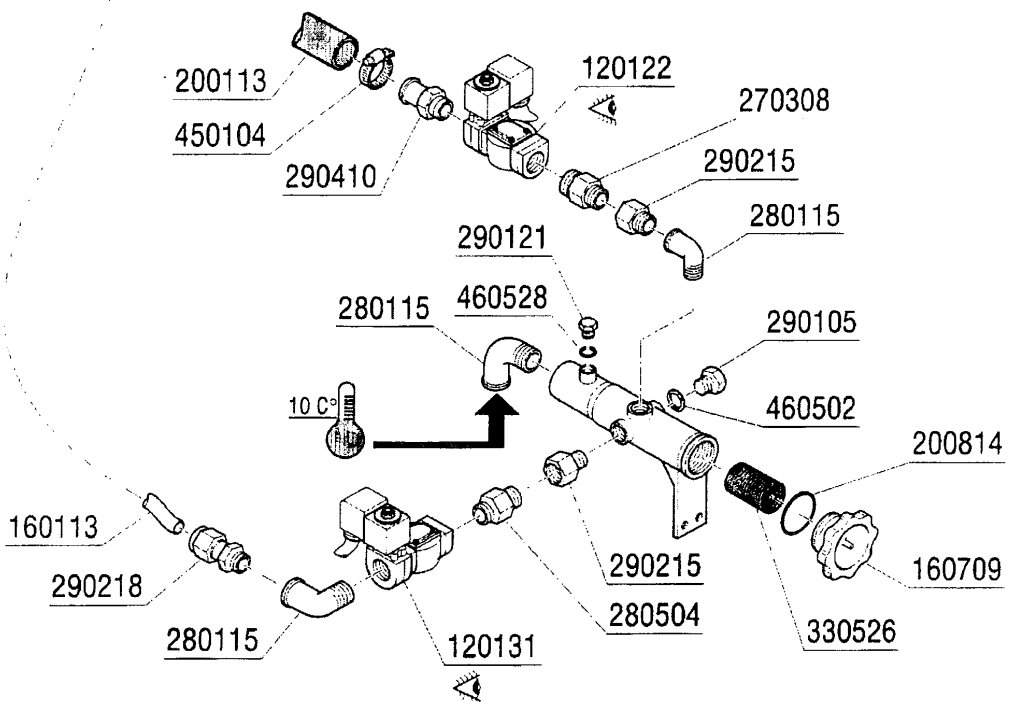
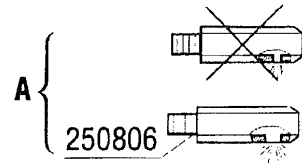
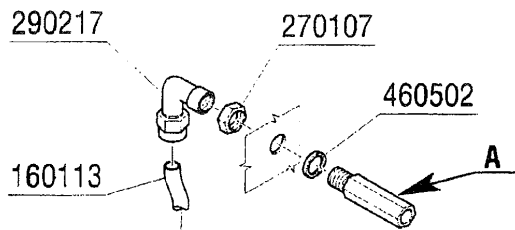

REV. 00
10/1999 - S.AG.

DAMPF-VENTIL - ELETTROVALVOLA VAPORE - ELECTROVANNE VAPEUR
 STEAM SOLENOID VALVE - ELECTROVALVULA VAPOR

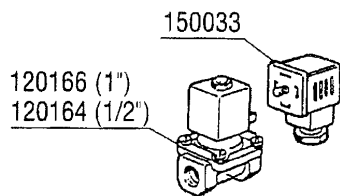

0 + 2 bar

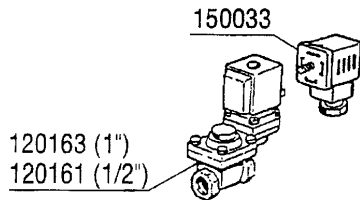
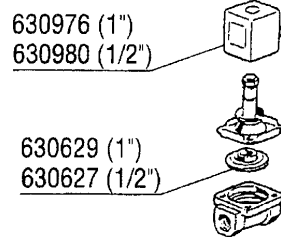

0,5 ÷ 2,5 bar

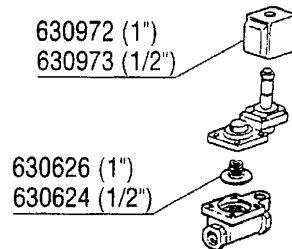

WASSER-VENTIL - ELETTROVALVOLA ACQUA - ELECTROVANNE EAU
 WATER SOLENOID VALVE - ELECTROVALVULA AGUA

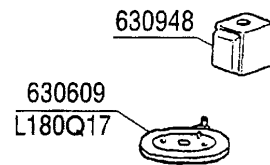
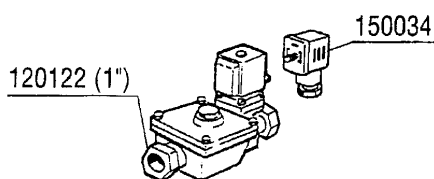
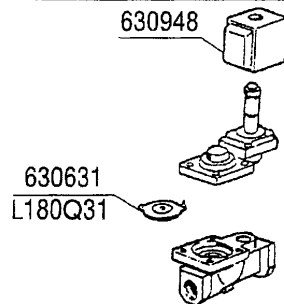
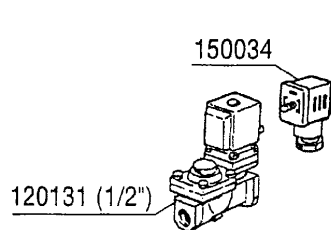

FÜR WÄRMERÜCKGEWINNUNG - PER RECUPERATORE DI CALORE - POUR ECONOMISEUR D'ENERGIE
 FOR HEAT RECOVERY UNIT - PARA RECUPERADOR DE CALOR

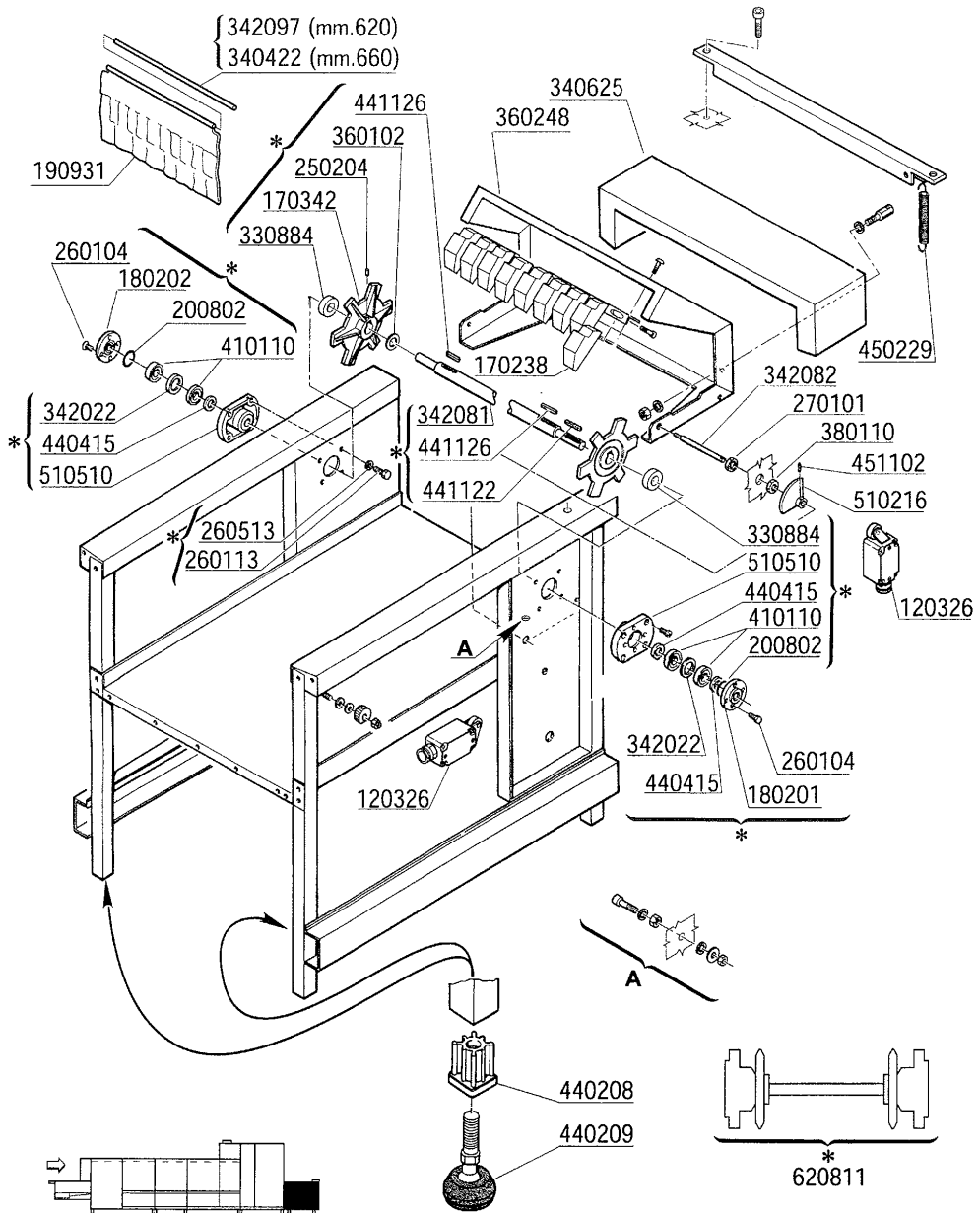

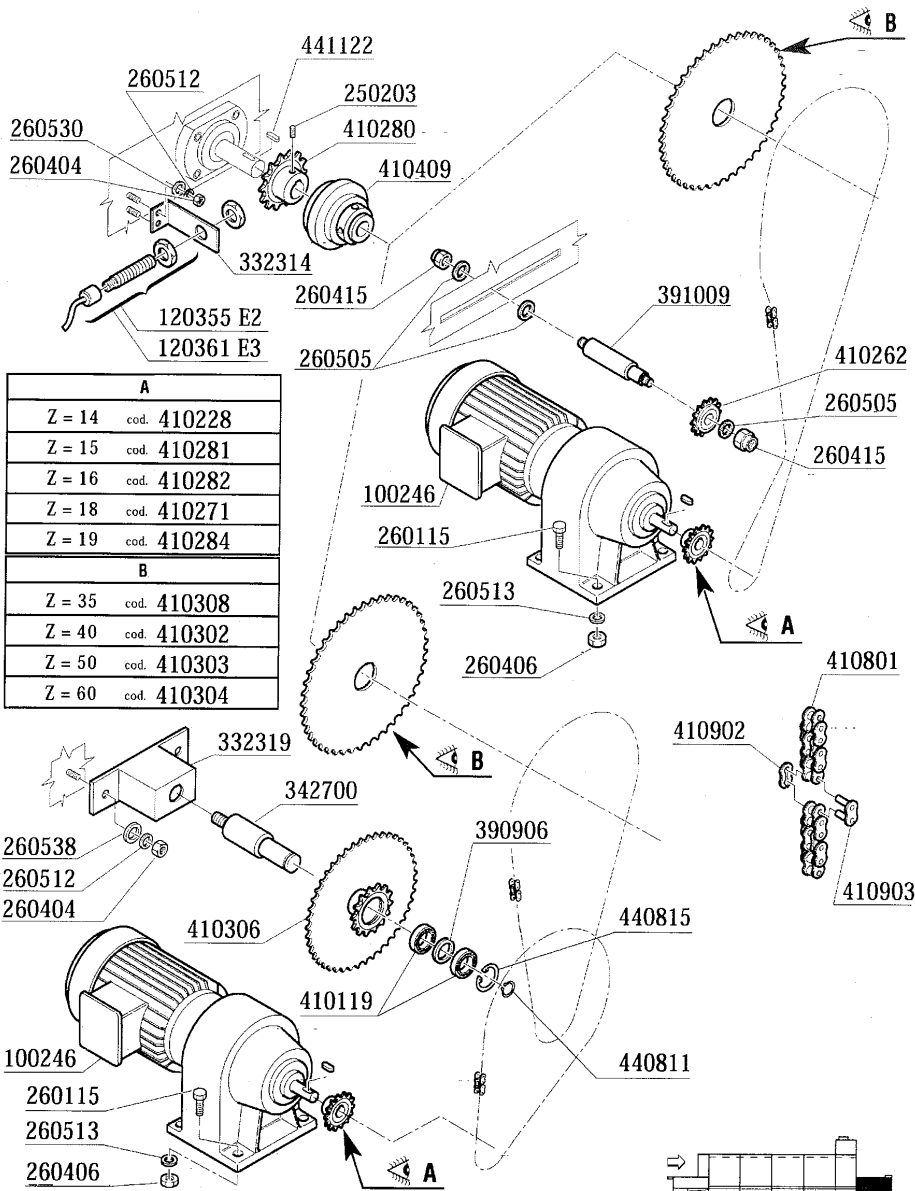

A	
Z = 14	cod. 410228
Z = 15	cod. 410281
Z = 16	cod. 410282
Z = 18	cod. 410271
Z = 19	cod. 410284
B	
Z = 35	cod. 410308
Z = 40	cod. 410302
Z = 50	cod. 410303
Z = 60	cod. 410304

REV. 00
01 - 2005 S.A.G.

NOTE: _____

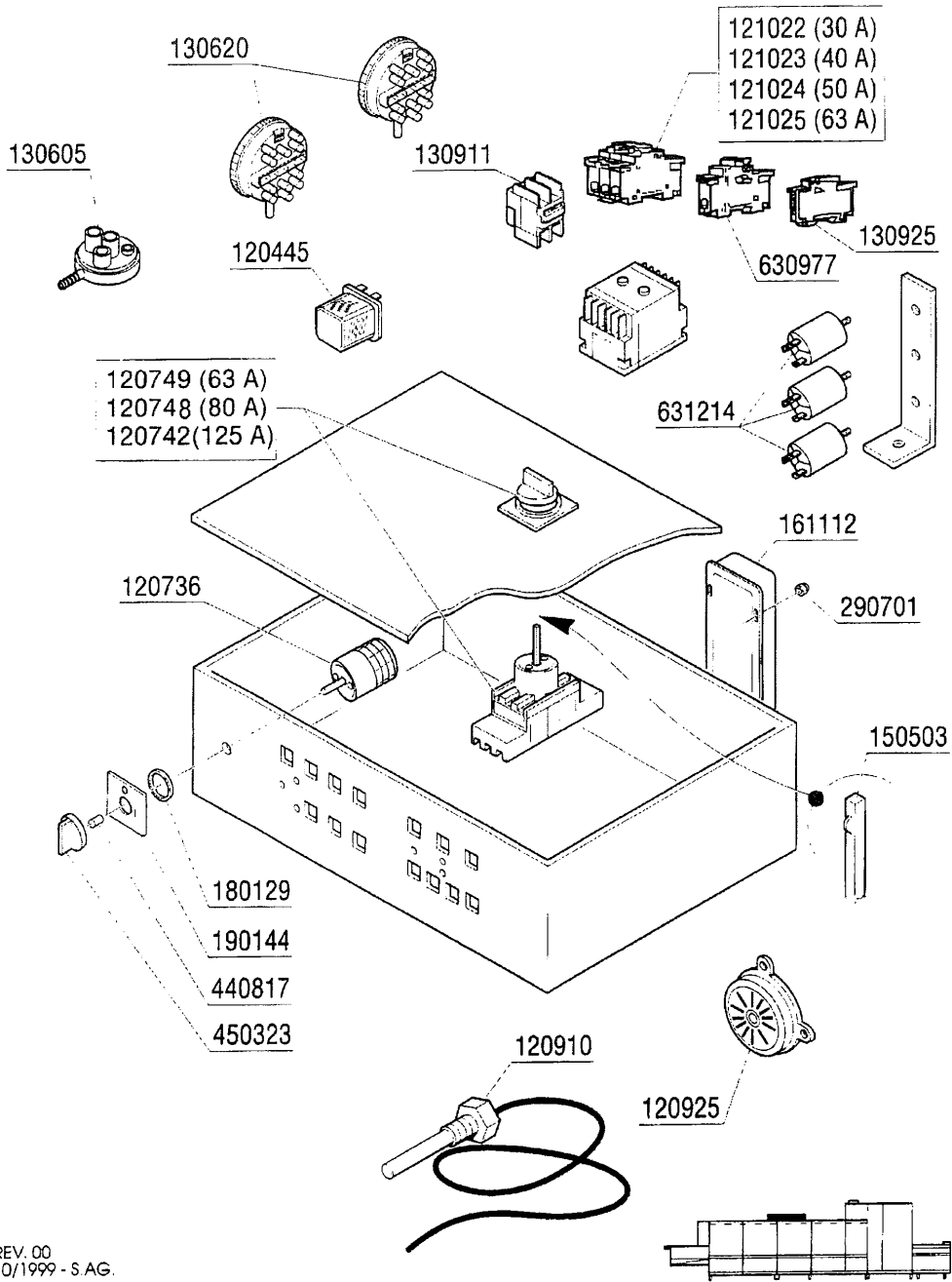

REV. 00
 10/1999 - S.A.G.

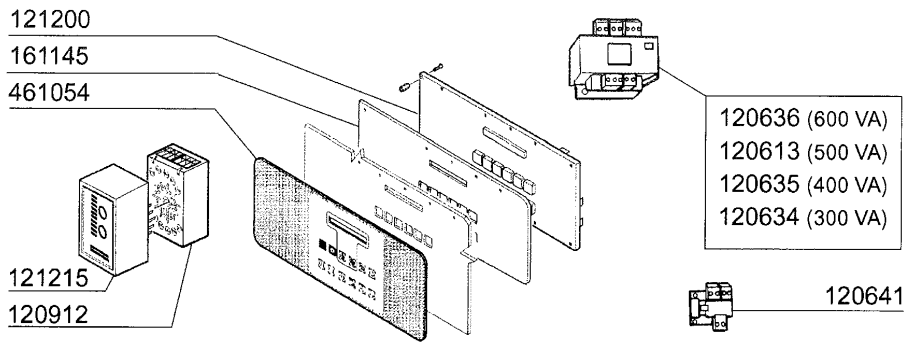

E1

E2

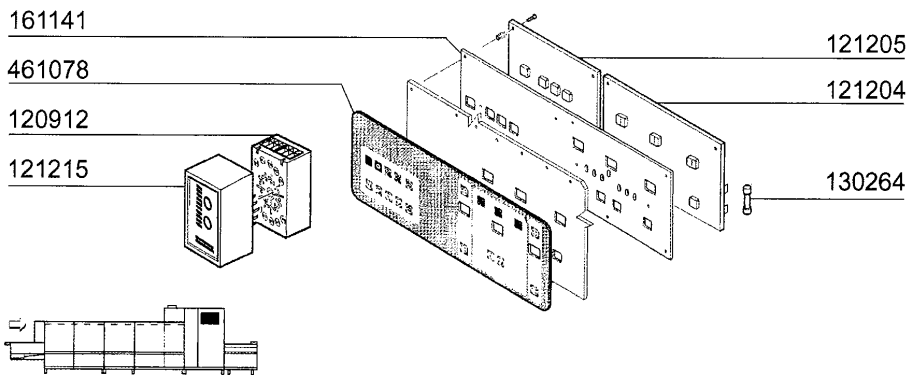
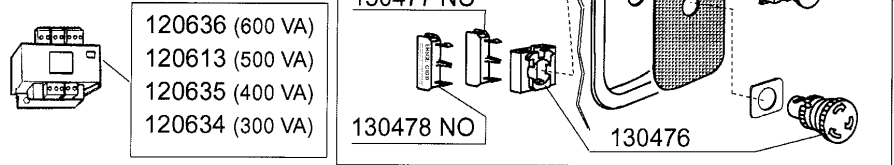

REV.00 05 - 2002 - S. AG.	NOTE _____
------------------------------	------------

E 3

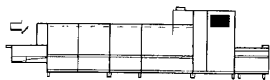
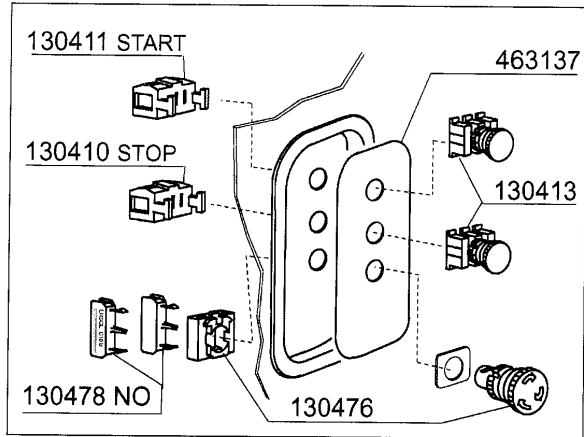
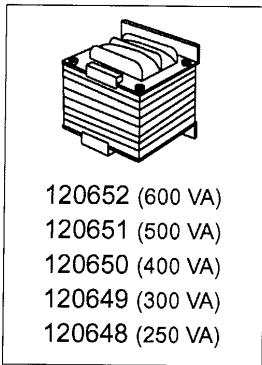
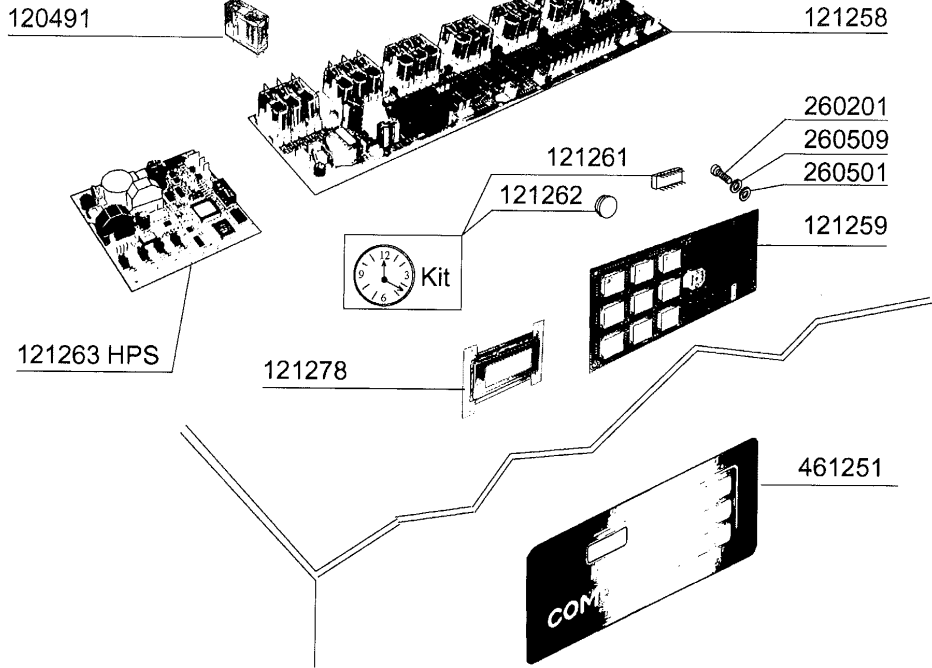

DC

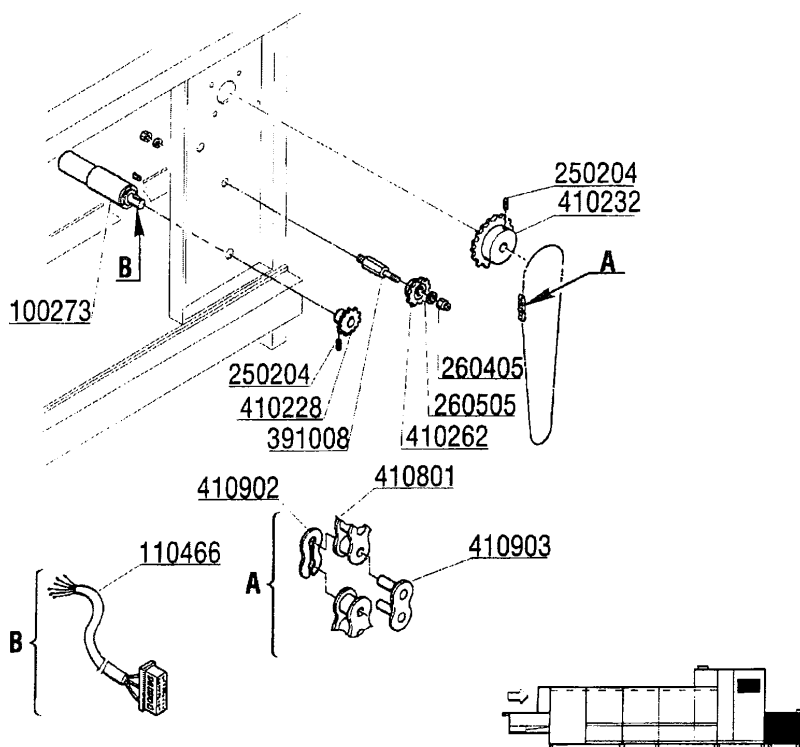
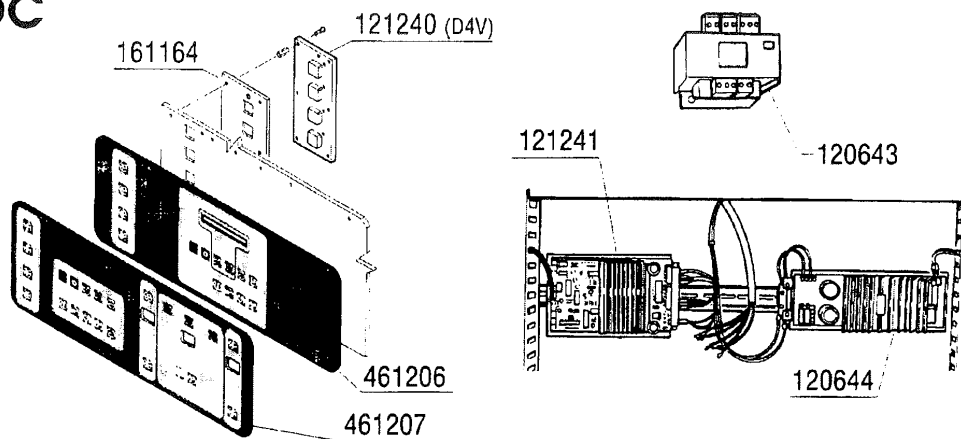

REV. 00
10/1999 - S.A.G.

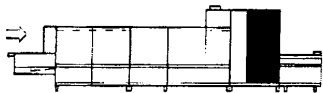
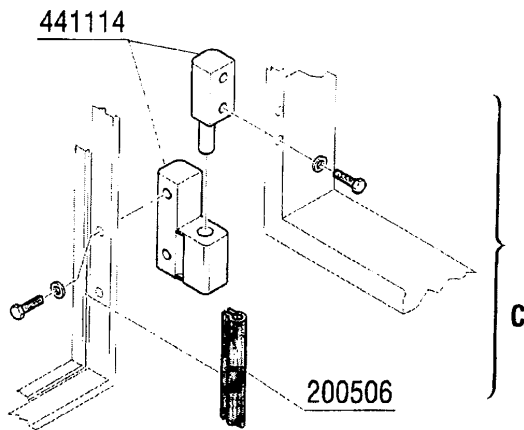
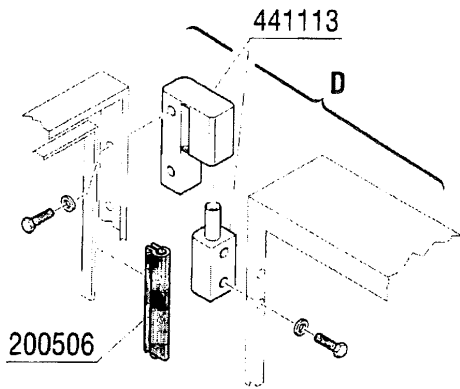
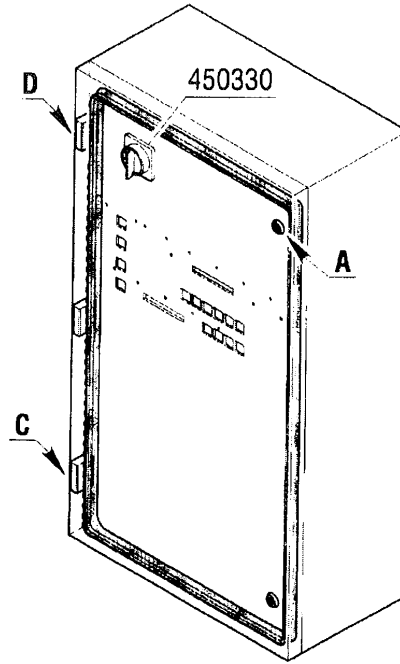
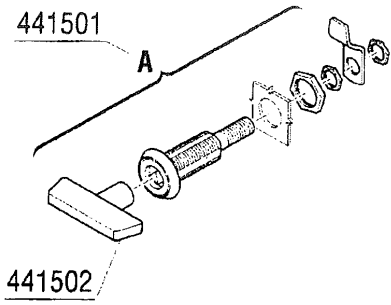

REV. 00
10/1999 - S.A.G.

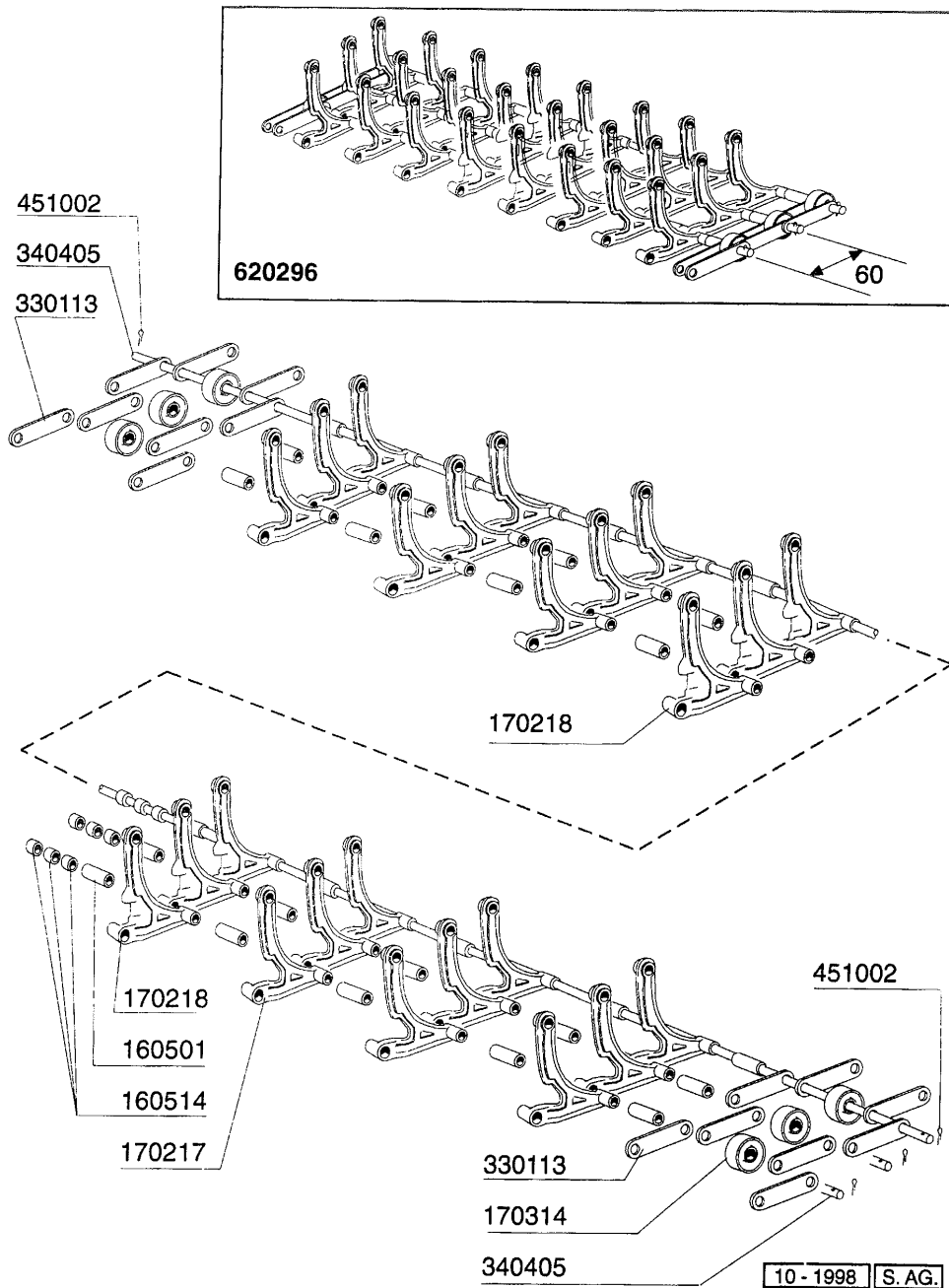

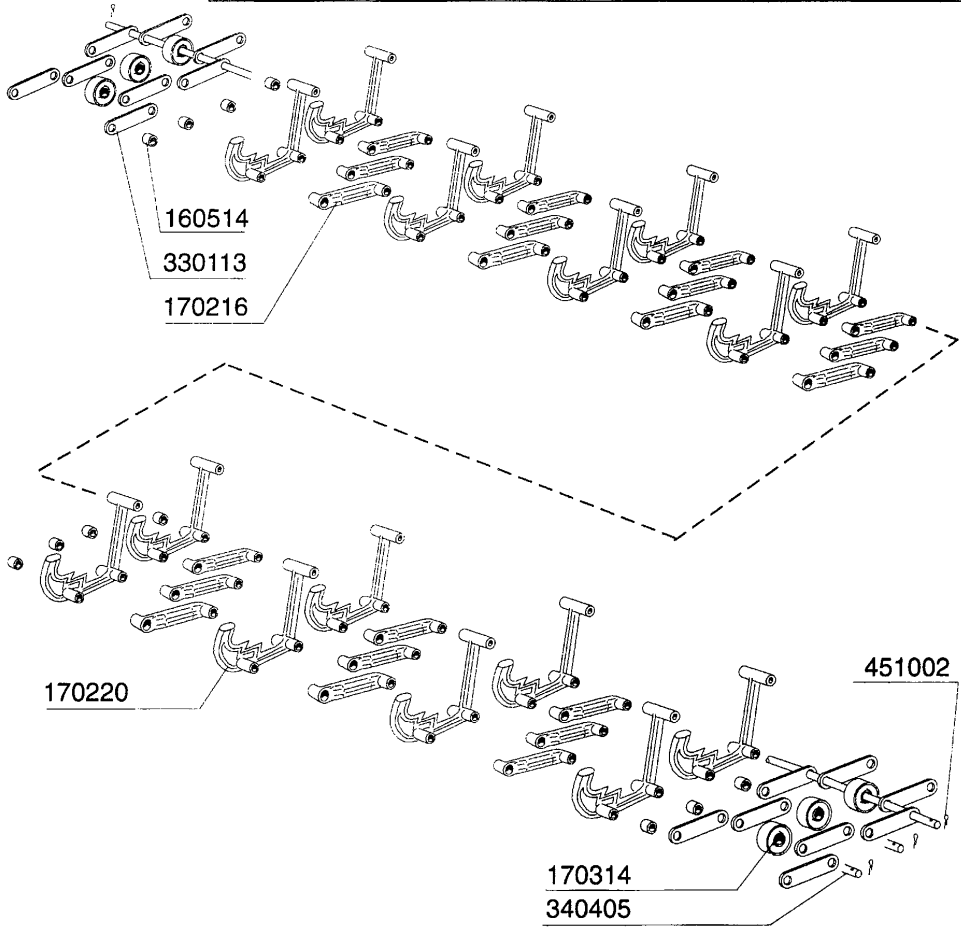
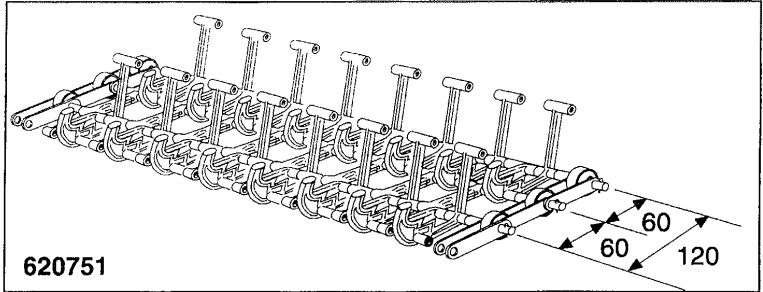

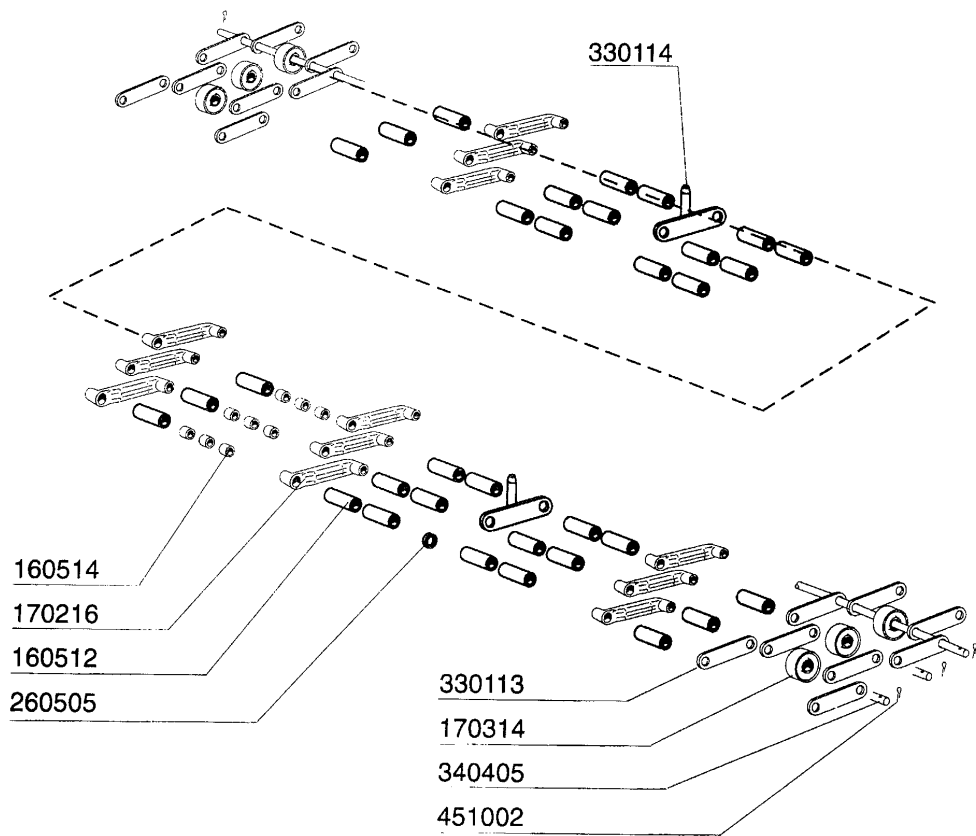
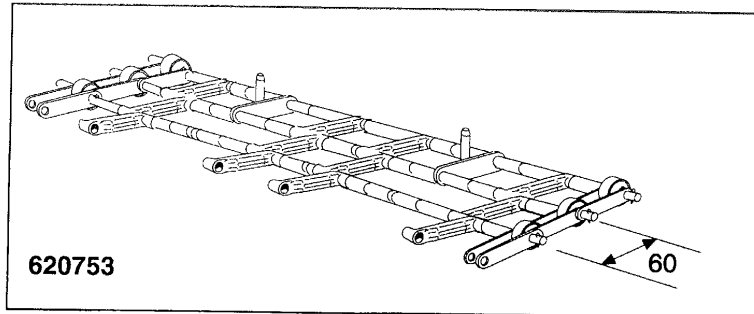

VORSPÜLUNGSPUMPE - POMPA PRELAVAGGIO - PREWASH PUMP - POMPE PRELAVAGE - BOMBA PRELAVADO
1,5 KW (1204)

INOX
631669 (50 Hz) ø 90

630223
630501

630114

630411

630306

630216

100762 220-240-380-415 V
50 Hz-3

WASCHPUMPE - POMPA LAVAGGIO - WASH PUMP - POMPE LAVAGE - BOMBA LAVADO
2,7 KW (2275)

INOX
631678 (60 Hz) ø117
631672 (50 Hz) ø134,5

630232
630516

630122

630418

630315

100398 220/380 V 50 Hz-3
100633 240/415 V 50 Hz-3
100638 220/380 V 60 Hz-3

DOPPELNACHSPÜLUNGSPUMPE - POMPA DOPPIO RISCIAACQUO - DOUBLERINSE PUMP
POMPE DOUBLE RINÇAGE - BOMBA DOBLE ACLARADO
0,15 KW (4226)

INOX
ø 60 (60 Hz)
631675 ø 72 (50 Hz)

630235
630511

630125

630416



100647 220/240/380/415 V 50 Hz-3
100669 240/240/380/415 V 60 Hz-3

ELEKTRISCHE TEILE FÜR PUMPEN - COMPONENTI ELETTRICI POMPE - COMPOSANTS ELECTRIQUES POMPES -
ELECTRICAL PARTS FOR PUMPS - PIEZOS ELECTRICOS PARA BOMBAS



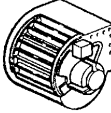

220/240 V					380/415 V				
PUMPE POMPA POMPE PUMP BOMBA	SCHALTSCHÜTZ TELERUTTORE CONTACTEUR CONTACTOR CONTACTOR	MAGNETISCHER SCHLITER FÜR MOTORE MAGNETOTERMICI PER MOTORI MAGNETO-THERMIQUE TERMO-MAGNETIC SWICH FOR MOTOR MAGNETO-TÉRMICO PARA MOTORES			SCHALTSCHÜTZ TELERUTTORE CONTACTEUR CONTACTOR CONTACTOR		MAGNETISCHER SCHLITER FÜR MOTORE MAGNETOTERMICI PER MOTORI MAGNETO-THERMIQUE TERMO-MAGNETIC SWICH FOR MOTOR MAGNETO-TÉRMICO PARA MOTORES		
		HP	Kw	A	cod.	A	cod.	A	cod.
0,2	0,15	9	120468	1+ 1,6	121030	9	120468	0,4 + 0,63	121028
2	1,5	9	120468	5,5 + 8	121034	9	120468	2,5 + 4	121032
3,7	2,7	17	120470	10 + 13	121035	9	120468	4 + 6,3	121033

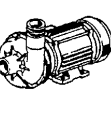
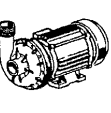
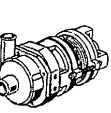
REV. 00
11/1998 - S.AG.

NOTE: _____

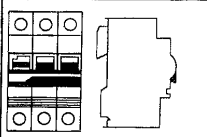
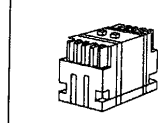
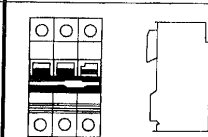
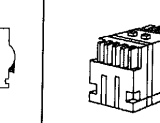
	220/240 V 3 ~				380/415 V 3 ~				
	KW	SCHALTSCHÜTZ TELERUTTORE CONTACTEUR CONTACTOR	A	MAGNETISCHER SCHALTER FÜR MOTORE MAGNETOTERMICI PER MOTORI MAGNETO-THERMIQUE TERMO-MAGNETIC SWICH FOR MOTOR MAGNETO-TÉRMICO PARA MOTORES	A	SCHALTSCHÜTZ TELERUTTORE CONTACTEUR CONTACTOR	A	MAGNETISCHER SCHALTER FÜR MOTORE MAGNETOTERMICI PER MOTORI MAGNETO-THERMIQUE TERMO-MAGNETIC SWICH FOR MOTOR MAGNETO-TÉRMICO PARA MOTORES	A
	1,5	120468	9	121033	4 + 6,3	120468	9	121032	2,5+4
	1,2	120468	9	121030	1+1,6	120468	9	121027	0,25+0,4
	1,5	120468	9	121033	4+6,3	120468	9	121032	2,5+4
	2,7	120470	16	121035	9+12,5	120468	9	121033	4+6,3
	0,15	120468	9	121030	1+1,6	120468	9	121028	0,4+0,63

NOTE: _____	REV. 00 11/1998 - S.A.G.
-------------	-----------------------------

		220/240 V				380/415 V				
										
KW	A	TERMO-MAGNETISCHER SCHALTER F. HEIZKÖRPER MAGNETO TERMICO RESISTENZA MAGNETO-TERMIQUE RESISTANCE TERMO-MAGNETIC SWITCH FOR HEATER MAGNETO-TERMICO RESISTENCIA		SCHALTSCHÜTZ TELERUTTORE CONTACTEUR CONTACTOR		A	TERMO-MAGNETISCHER SCHALTER F. HEIZKÖRPER MAGNETO TERMICO RESISTENZA MAGNETO-TERMIQUE RESISTANCE TERMO-MAGNETIC SWITCH FOR HEATER MAGNETO-TERMICO RESISTENCIA		SCHALTSCHÜTZ TELERUTTORE CONTACTEUR CONTACTOR	
										
6,00	20	121020	25	12	120469	16	121019	22	9	120468
9,00	32	121022	40	26	120471	20	121020	25	12	120469
12	40	121023	40	26	120471	20	121020	25	12	120469
14	40	121023	55	30	120472	32	121022	40	26	120471
23	80	121026	85	50	120474	50	121024	60	40	120473
24	80	121026	95	63	120475	50	121024	60	40	120473
27	80	121026	95	63	120475	50	121024	60	40	120473

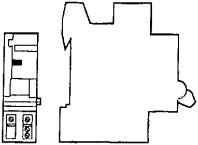
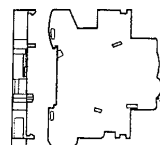
	
Cod. 630977	Cod. 130925
AUSLÖSESPÜLE V. 24 FÜR BOILER BOBINA DI SGANCIO V. 24 PER BOILER BOBINE DÉCROCHAGE V.24 POUR SURCHAUFFEUR DISCONNECTING COIL V.24 FOR BOILER BOBINA DESEMBRAGUE V. 24 POR BOILER	KONTAKT FÜR AUSLÖSESPÜLE CONTATTO PER BOBINA DI SGANCIO CONTACT BOBINE DÉCROCHAGE CONTACT FOR DISCONNECTING COIL CONTACTO POR BOILER DE DESEMBRAGUE

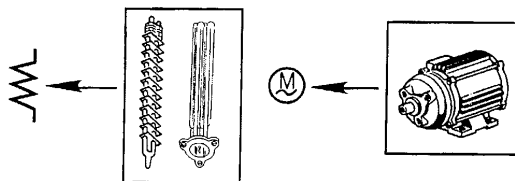

REV. 00
11/1998 - S.A.G.

NOTE: _____

MODELLO MODELE MODEL MODELL MODELO	PRELAVAGGIO 900 PRELAVAGE 900 PREWASH 900 WORWASCHZONE 900 PRELAVADO 900	1° LAVAGGIO 1 ^{RE} LAVAGE 1 ST WASH 1. WASCHZONE 1. LAVADO	2° LAVAGGIO 2 ^{DE} LAVAGE 2 ND WASH 2. WASCHZONE 2. LAVADO	3° LAVAGGIO 3 ^{ME} LAVAGE 3 RD WASH 3. WASCHZONE 3. LAVADO	4° LAVAGGIO 4 ^{ME} LAVAGE 4 TH WASH 4. WASCHZONE 4. LAVADO	DOPPIO RISCIACCO DOUBLE RINCE DOUBLE RINSE DOPPELNACHSPÜLUNG DOBLE ACLARADO	RISCIACCO RINCE RINSE NACHSPÜLUNG ACLARADO
NE 3002		8 KW + 6 KW				5 KW	8 KW + 8 KW
NE 4002		8 KW + 6 KW				5 KW	9 KW + 9 KW
NE 5002	9 KW	8 KW + 6 KW				6 KW	6 KW + 6 KW + 9 KW
NE 5502		6 KW + 6 KW	8 KW + 6 KW			6 KW	6 KW + 8 KW + 9 KW
NE 7002	9 KW	6 KW + 6 KW	8 KW + 6 KW			6 KW	8 KW + 8 KW + 8 KW
NE 7502		6 KW + 6 KW	6 KW + 6 KW	8 KW + 6 KW		6 KW	9 KW + 9 KW + 9 KW
NE 9002	9 KW	6 KW + 6 KW	6 KW + 6 KW	8 KW + 6 KW		6 KW	9 KW + 9 KW + 10 KW
NE 9502		6 KW + 6 KW	6 KW + 6 KW	8 KW + 6 KW	8 KW + 6 KW	6 KW	10 KW + 10 KW + 10 KW

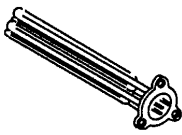
	380 / 415 V	
	6 KW	110349
	8 KW	110343
	9 KW	110362
	10 KW	110388

09 - 2000 | S. AG.

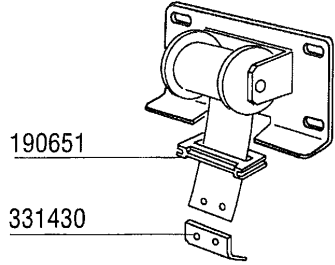
				
Cod.		391309	391318	391332
		Kg 4	Kg 4,5	Kg 5,5
Türtyp Tipo porta Type porte Door type Modelo puerta	Kg			
600	15			N. 2 = 11 Kg
900	21,5	N. 4 = 16 Kg		

REV. 01 11/1998 - S. AG.	NOTE: _____ _____
-----------------------------	----------------------