

**ISTRUZIONI PER L'INSTALLAZIONE E L'USO**  
**INSTRUCTIONS FOR INSTALLATION AND USE**  
**INSTRUCTIONS POUR L'INSTALLATION ET MODE D'EMPLOI**  
**INSTALLATIONS- UND GEBRAUCHSANWEISUNG**  
**INSTRUCCIONES PARA LA INSTALACIÓN Y PARA EL USO**

**WF 8 - WF 11 - WF 18**  
**WF 23 - WF 26 - WF 33**

**LAVATRICE**

PROGRAMMATORE A CAMME + MICROPROCESSORE

**WASHING MACHINE**

CAM CONTROL MODELS + MICROPROCESSOR

**MACHINE À LAVER**

PROGRAMMEUR À CAMMES + MICROPROCESSEUR

**WASCHMASCHINE**

PROGRAMMSCHALTER MIT NOCKEN + MIKROPROZESSOR

**LAVADORA**

PROGRAMADOR A CAMAS + MICROPROCESADOR



**grandimpianti®**  
**Industrial Laundry Equipment**

LAVA-F.07

VIA MASIERE, 211/C  
32037 - SOSPIROLO (BL)  
ITALY

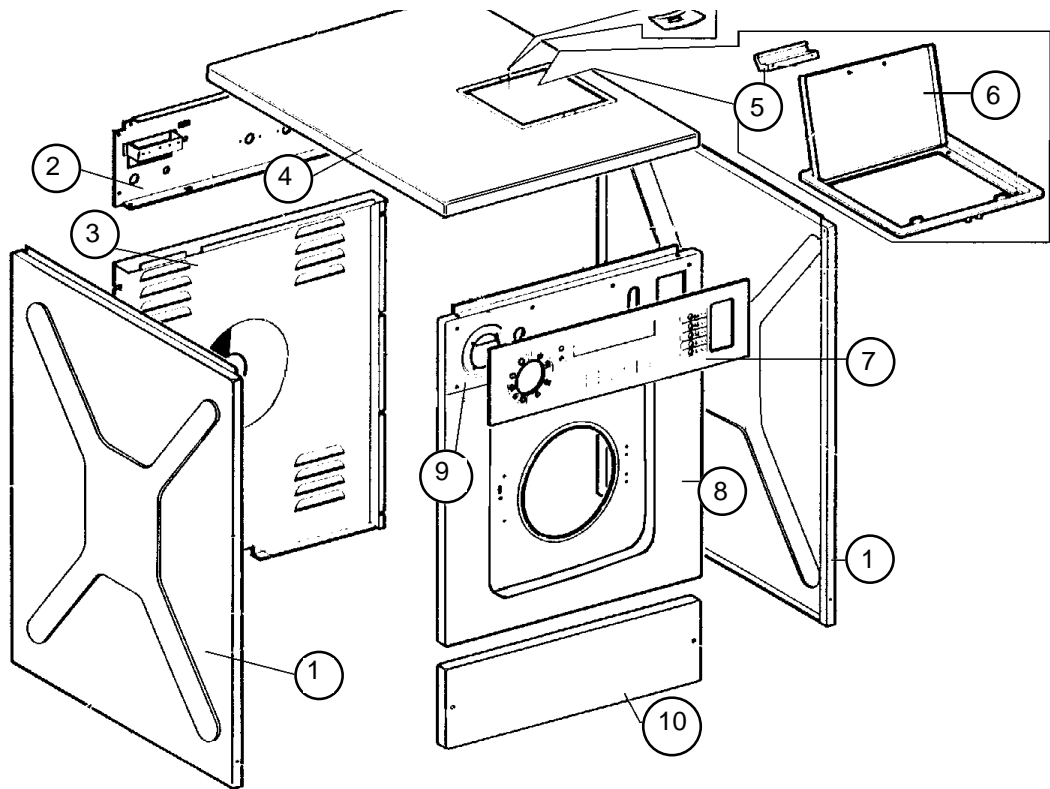

F/8-11-18-23-26-33/1

Pos.	Mod.	8	11	18	Descrizione	Description	Déscription	Beschreibung	Descripción
1	421113212300	•			Pannello laterale Dx - Sx	Side panel right-left	Panneau latéral Droite -Gauche	Seitenverkleidung rechts-links	Panel lateral derecha-izquierda
1	421113272600		•		Pannello laterale Dx - Sx	Side panel right-left	Panneau latéral Droite -Gauche	Seitenverkleidung rechts-links	Panel lateral derecha-izquierda
1	421110013600		•		Pannello laterale Dx - Sx	Side panel right-left	Panneau latéral Droite -Gauche	Seitenverkleidung rechts-links	Panel lateral derecha-izquierda
2	421113110400	•	•		Schiene superiore	Upper rear panel	Panneau arrière supérieur	Obere Rückenverkleidung	Panel superior trasero
2	421113210400			•	Schiene superiore	Upper rear panel	Panneau arrière supérieur	Obere Rückenverkleidung	Panel superior trasero
3	421110005500	•	•		Schiene inferiore	Lower rear panel	Panneau arrière inférieur	Untere Rückenverkleidung	Panel inferior trasero
3	4211100123B0			•	Schiene inferiore	Lower rear panel	Panneau arrière inférieur	Untere Rückenverkleidung	Panel inferior trasero
4	421113214100	•	•		Coperchio	Top of cabinet	Couvercle	Deckel	Tapa
4	421113274200			•	Coperchio	Top of cabinet	Couvercle	Deckel	Tapa
5	422230000805	•	•	•	Maniglia coperchio dispenser	Handle for soap dispenser lid	Poignée couvercle dispenser	Griff für den Deckel des Waschmittelb.	Manija tapa del recipiente de jabón
6	421230010301	•	•	•	Coperchio completo dispenser	Soap dispenser lid	Couvercle dispenser complet	Deckel für Waschmittelbehälter	Tapa del recipiente de jabón
7	420400000005	•	•		Cruscotto	Fascia panel	Panneau contrôle	Schaltbrett	Panel de control
7	420400000010			•	Cruscotto	Fascia panel	Panneau contrôle	Schaltbrett	Panel de control
8	421110019900	•	•		Pannello centrale frontale	Central front panel	Panneau central frontal	Mittlere Frontverkleidung	Panel delantero central
8	421110021000			•	Pannello centrale frontale	Central front panel	Panneau central frontal	Mittlere Frontverkleidung	Panel delantero central
9	421110022501	•	•		Pannello frontale superiore	Upper front panel	Panneau frontal supérieur	Obere Frontverkleidung	Panel frontal superior
9	421110022701			•	Pannello frontale superiore	Upper front panel	Panneau frontal supérieur	Obere Frontverkleidung	Panel frontal superior
10	421113213100	•	•		Pannello frontale inferiore	Lower front panel	Panneau frontal inférieur	Untere Frontverkleidung	Panel delantero inferior
10	421113273100			•	Pannello frontale inferiore	Lower front panel	Panneau frontal inférieur	Untere Frontverkleidung	Panel delantero inferior

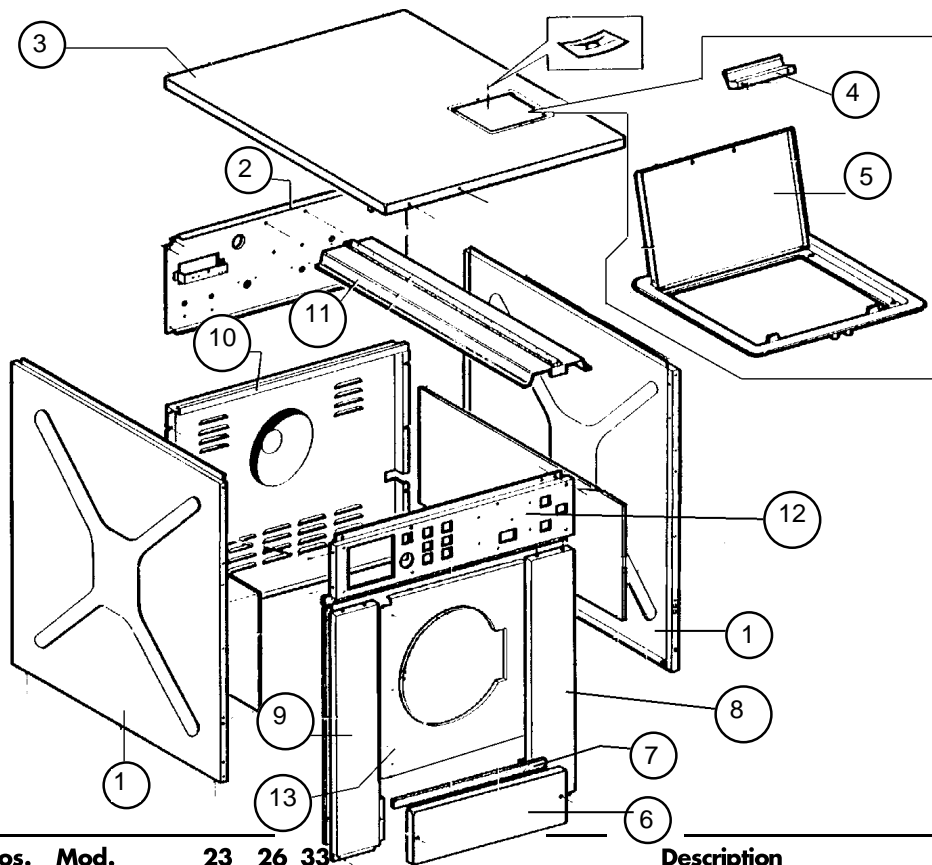

**F/8-11-18-23-26-33/2**

Pos.	Mod.	23	26	33	Description	Déscription	Beschreibung	Descripción	
1	42140000700	•	•		Pannello laterale Dx - Sx	Side panel right-left	Panneau latéral droite - gauche	Seitenverkleidung rechts-links	Panel lateral derecho-izquierdo
1	421330012600		•		Pannello laterale Dx - Sx	Side panel right-left	Panneau latéral droite - gauche	Seitenverkleidung rechts-links	Panel lateral derecho-izquierdo
2	42140000490	•	•		Schienna superiore	Upper rear panel	Panneau arrière supérieur	Obere Rückenverkleidung	Panel superior trasero
2	421330000100		•		Schienna superiore	Upper rear panel	Panneau arrière supérieur	Obere Rückenverkleidung	Panel superior trasero
3	421113295000	•	•		Coperchio	Top panel	Couvercle	Deckel	tapa
3	421113294200		•		Coperchio	Top panel	Couvercle	Deckel	tapa
4	422230000805	•	•	•	Maniglia coperchio dispenser	Handle for soap dispenser lid	Poignée couvercle dispenser	Griff für den Deckel des Waschmittelbehälters	Manija tapa del recipiente de jabón
5	421230010301	•	•	•	Coperchio dispenser completo	Soap dispenser lid	Couvercle dispenser complet	Deckel für Waschmittelbehälter	tapa recipiente de jabón
6	421113294300	•	•	•	Pannello frontale inferiore	Lower front panel	Panneau inférieur	Untere Frontverkleidung	Panel delantero inferior
7	422460014900	•	•	•	Guarnizione frontale	Front gasket	Joint frontal	Frontdichtung	Junta delantera
8	421113295700	•	•		Pannello frontale destro	Right front panel	Panneau frontal droit	Rechte Frontverkleidung	Panel derecho delantero
8	421113296000		•		Pannello frontale destro	Right front panel	Panneau frontal droit	Rechte Frontverkleidung	Panel derecho delantero
9	421113295100	•	•		Pannello frontale sinistro	Left front panel	Panneau frontal gauche	Linke Frontverkleidung	Panel izquierdo delantero
9	421113294800		•		Pannello frontale sinistro	Left front panel	Panneau frontal gauche	Linke Frontverkleidung	Panel izquierdo delantero
10	421110012700	•	•		Pannello posteriore	Rear panel	Panneau arrière	Hintere Verkleidung	Panel posterior
10	421110012600		•		Pannello posteriore	Rear panel	Panneau arrière	Hintere Verkleidung	Panel posterior
11	421110013000	•	•		Supporto dispenser	Dispenser support	Support dispenser	Halter für Waschmittelbehälter	Sostén para recipiente de jabón
11	421113295400		•		Supporto dispenser	Dispenser support	Support dispenser	Halter für Waschmittelbehälter	Sostén para recipiente de jabón
12	421113270600	•	•		Pannello frontale superiore	Upper front panel	Panneau frontal supérieur	Obere Frontverkleidung	Panel frontal superior
12	421110500800		•		Pannello frontale superiore	Upper front panel	Panneau frontal supérieur	Obere Frontverkleidung	Panel frontal superior
13	421113255900	•	•		Pannello frontale centrale	Central front panel	Panneau frontal central	Mittlere Frontverkleidung	Panel frontal central
13	421113256100		•		Pannello frontale centrale	Central front panel	Panneau frontal central	Mittlere Frontverkleidung	Panel frontal central

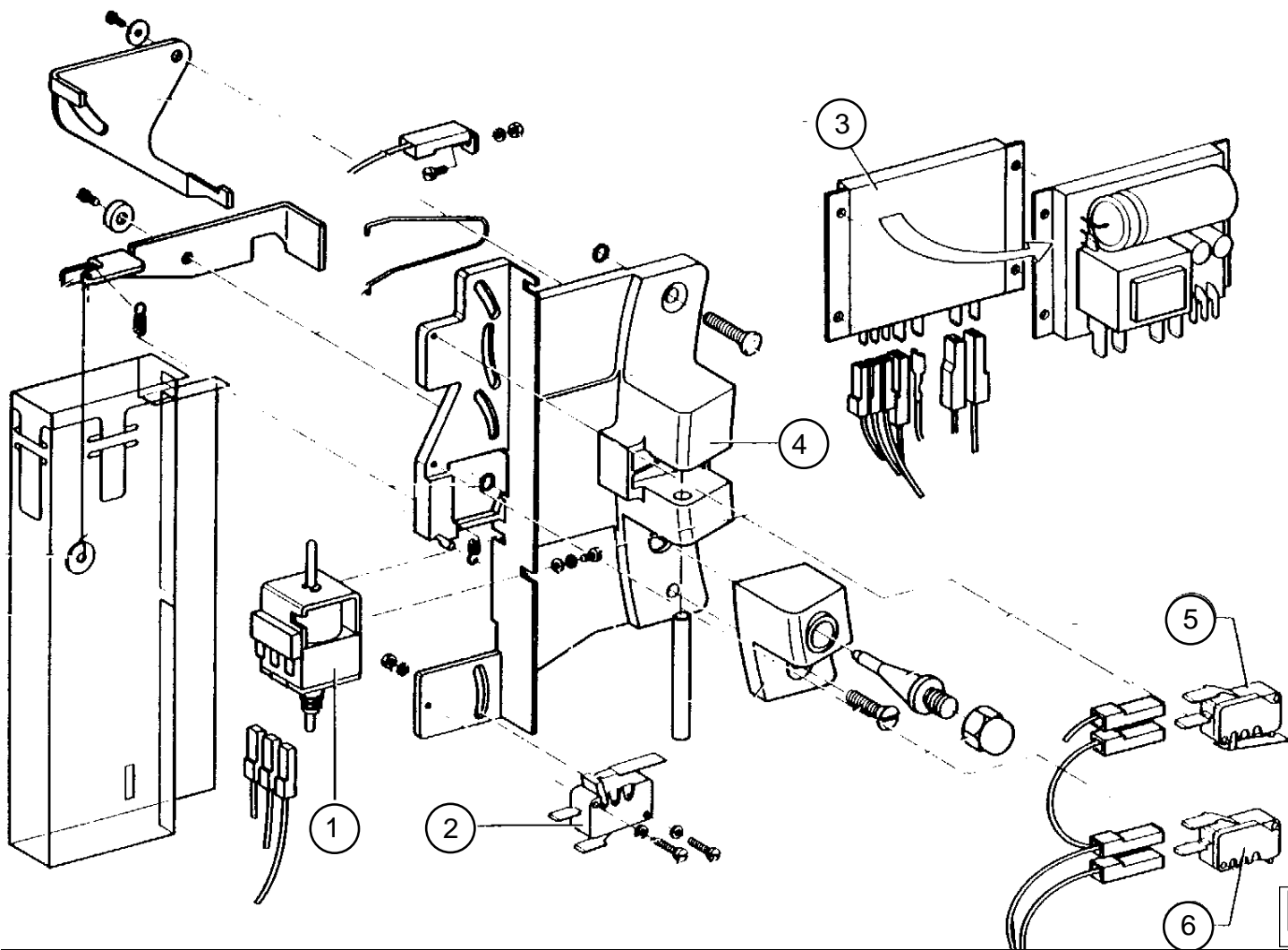

**F/8-11-18-23-26-33/3**

Pos.	Mod.	8	11	18	23	26	33	Descrizione	Description	Déscription	Beschreibung	Descripción
1	422090027400	•	•	•	•	•	•	Bobina chiusura oblo (compl.)	Coil lock (complete)	Bobine serrure (compl.)	Magnet für Türverriegelung (kompl.)	Bobina para cerradura (compl.)
2	422090027300	•	•	•	•	•	•	Micro chiusura oblo (NC)	Lock microswitch (NC)	Microinter. serrure (NC)	Mikroschal. für Türverriegelung (NC)	Microint. cerradura (NC)
3	422090027502	•	•	•	•	•	•	Scheda elett.chiusura oblo	Door lock print board	Carte électr. fermeture porte	Elektronische Platte für Türverrieg.	Ficha electrón. cierre puerta
4	422170005200	•	•	•	•	•	•	Serratura completa	Lock body	Serrure compl.	Komplette Türverriegelung	Cerradura completa
5	422090027100	•	•	•	•	•	•	Micro chiusura oblo (NO)	Lock Microswitch (NO)	Microinter. serrure (NO)	Mikroschal. für Türverrieg.(NO)	Microinterruptor puerta (NO)
6	50 GI 851009	•	•	•	•	•	•	Micro chiusura oblo (NC)	Lock Microswitch (NC)	Microinter. serrure (NC)	Mikroschal. für Türverrieg.(NC)	Microinterruptor puerta (NC)
								NO Normalmente aperto	Normally open	Normalement ouvert	Normalerweise offen	Normalmente abierto
								NC Normalmente chiuso	Normally closed	Normalement fermé	Normalerweise geschlossen	Normalmente cerrado

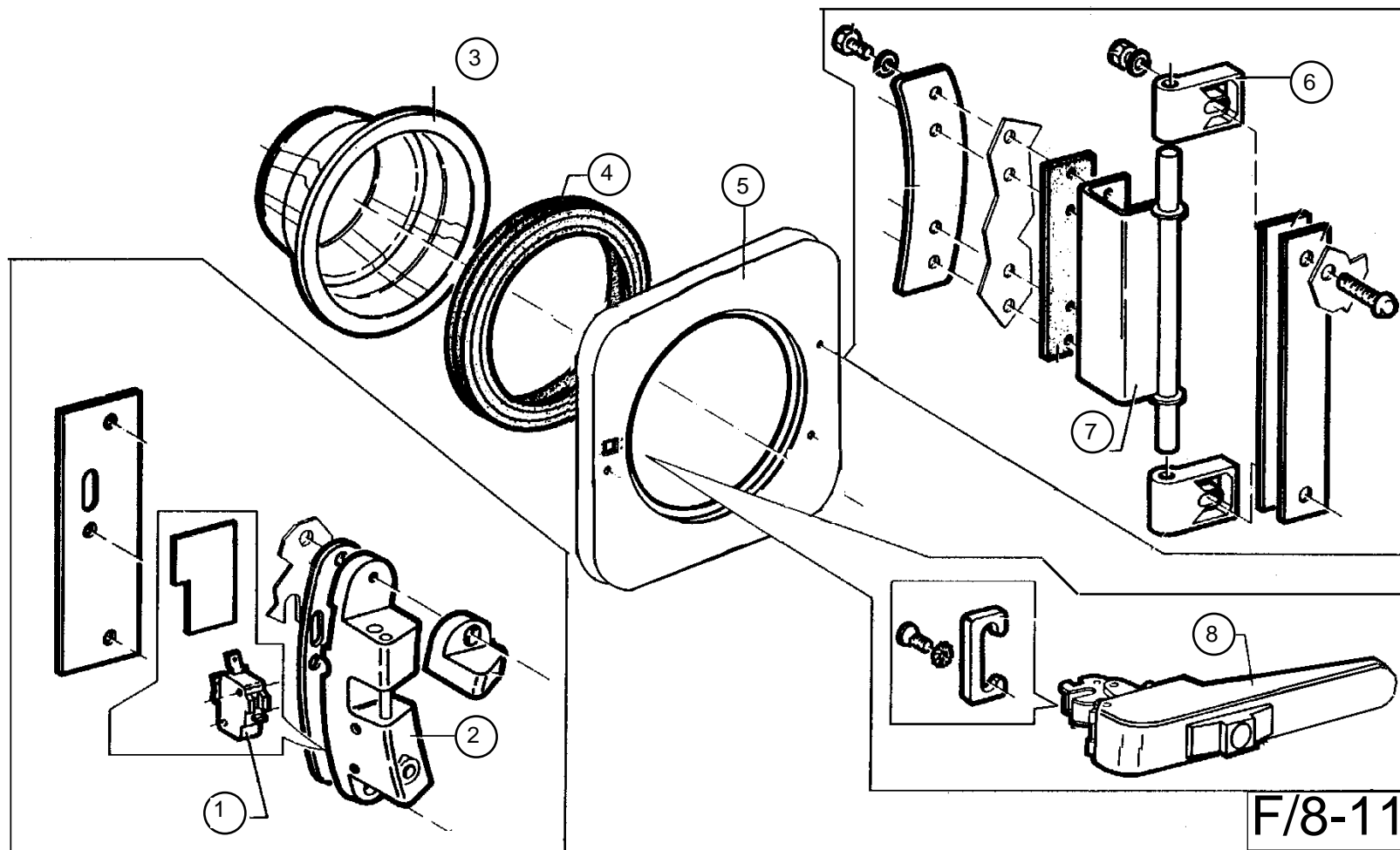

F/8-11-18-23-26-33/4

Pos.	Mod.	8	11	18	23	26	33	Descrizione	Description	Déscription	Beschreibung	Descripción
1	422090002300	.	.	.	.	.	.	Micro scontro oblo	Door ward microswitch	Microinter. recontre porte	Mikroschalter für Türkontakt	Micro choque puerta
2	422170001701	.	.	.	.	.	.	Scontro oblo	Door ward	Rencontre porte	Türkontakt	Cierre puerta
3	422170002200	.	.	.	.	.	.	Vetro oblo	Door glass	Verre hublot	Türglas	Vidrio puerta
3	422310000400	.	.	.	.	.	.	Vetro oblo	Door glass	Verre hublot	Türglas	Vidrio puerta
4	422170001500	.	.	.	.	.	.	Guarnizione oblo	Door gasket	Joint hublot	Türdichtung	Junta puerta
4	4222300006800	.	.	.	.	.	.	Guarnizione oblo	Door gasket	Joint hublot	Türdichtung	Junta puerta
5	4211800006400	.	.	.	.	.	.	Cornice oblo	Door frame	Corniche porte	Türrahmen	Marco puerta
5	421310000300	.	.	.	.	.	.	Cornice oblo	Door frame	Corniche porte	Türrahmen	Marco puerta
6	422170000902	.	.	.	.	.	.	Cerniera girevole	Mobile door hinge	Charnière pivotante	Drehbare Türscharniere	Bisagra móvil
7	4213100004000	.	.	.	.	.	.	Cerniera fissa	Fixed door hinge	Charnière fixe	Feste Türscharniere	Bisagra fija
7	4213100004600	.	.	.	.	.	.	Cerniera fissa	Fixed door hinge	Charnière fixe	Feste Türscharniere	Bisagra fija
8	4221700005500	.	.	.	.	.	.	Maniglia oblo pulsante nero	Black button door handle	Poignée porte bouton noir	Türgriff mit schwarzem Knopf	Manija con botón negro

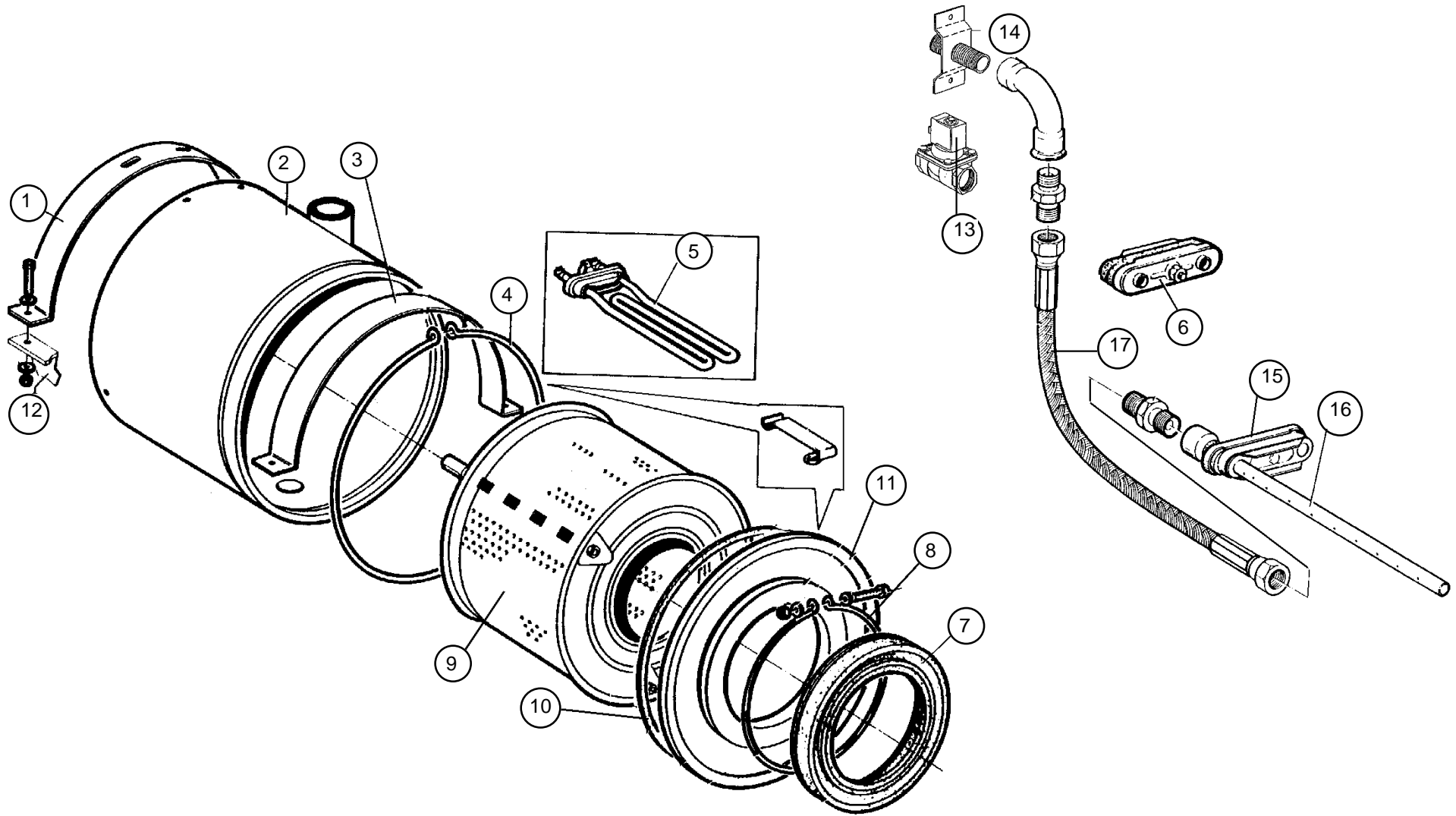

F/8-11-18-23-26-33/5

# F/8-11-18-23-26-33/5

Pos.	Mod.	8	11	18	Descrizione	Description	Déscription	Beschreibung	Descripción
1	421150010800	•	•		Anello superiore fissaggio vasca	Tub upper fastening ring	Anneau supérieur fixation cuve	Oberer Befestigungsring für den Bottich	Anillo superior cierre cuba
1	421150011100			•	Anello superiore fissaggio vasca	Tub upper fastening ring	Anneau supérieur fixation cuve	Oberer Befestigungsring für den Bottich	Anillo superior cierre cuba
2	421180005700	•			Vasca mod. 8	Tub mod. 8	Cuve mod. 8	Bottich Mod. 8	Cuba mod. 8
2	421180009800		•		Vasca mod.11	Tub mod. 11	Cuve mod. 11	Bottich Mod. 11	Cuba mod. 11
2	421190006100			•	Vasca mod. 18	Tub mod. 18	Cuve mod. 18	Bottich Mod.18	Cuba mod. 8
3	421150010800	•	•		Anello di fissaggio vasca	Tub fastening ring	Anneau fixation cuve	Befestigungsring für den Bottich	Anillo de cierre cuba
3	421150011000			•	Anello di fissaggio vasca	Tub fastening ring	Anneau fixation cuve	Befestigungsring für den Bottich	Anillo de cierre cuba
4	422170000700	•	•		Anello fissaggio pannello frontale	Fatening ring for front panel	Cercle de fixation panneau avant	Haltering für Frontverkleidung	Anillo de cierre panel delantero
4	422190000700			•	Anello fissaggio pannello frontale	Fatening ring for front panel	Cercle de fixation panneau avant	Haltering für Frontverkleidung	Anillo de cierre panel delantero
5	422090011601	•	•	•	Resistenza 1400W/220V	Heating element 1400W/220V	Élément chauffant 1400W/220V	Heizwiderstand 1400W/220V	Resistencia 1400W/220V
5	50 GI 851112	•	•	•	Resistenza 2000W/220V	Heating element 2000W/220V	Élément chauffant 2000W/220V	Heizwiderstand 2000W/220V	Resistencia 2000W/220V
5	50 GI 851113	•	•	•	Resistenza 3000W/220V	Heating element 3000W/220V	Élément chauffant 3000W/220V	Heizwiderstand 3000W/220V	Resistencia 3000W/220V
5	422090005001			•	Resistenza 4000W/380V	Heating element 4000W/380V	Élément chauffant 4000W/380V	Heizwiderstand 4000W/380V	Resistencia 4000W/380V
6	50 GI 801093	•	•	•	Tappo silicone foro stretto	Silicone plug for narrow hole	Bouchon trou étroit en silicone	Silikonstopfen für enges Loch	Tapón de silicona para orificio estrecho
7	422230012200	•	•	•	Guarnizione vasca - oblo	Rubber tunnel	Tunnel caoutchouc	Gummidichtung für Tür und Bottich	Junta de goma para puerta y cuba
8	422380001200	•	•	•	Anello fissaggio guarnizione	Rubber tunnel fastening ring	Cercle de fixation tunnel caoutchouc	Haltering für Gummidichtung	Anillo para junta de goma
9	421231000200	•			Cesto + albero	Drum + shaft	Tambour + axe	Trommel + Welle	Tambor + eje
9	421231003100		•		Cesto + albero	Drum + shaft	Tambour + axe	Trommel + Welle	Tambor + eje
9	421221002900			•	Cesto + albero	Drum + shaft	Tambour + axe	Trommel + Welle	Tambor + eje
10	422170000600	•	•	•	Guarnizione pannello frontale	Tub front panel gasket	Joint panneau frontal cuve	Dichtung für Frontverkleidung	Junta para panel frontal cuba
11	421180005403	•	•		Pannello frontale vasca	Tub front panel	Panneau frontal cuve	Frontverkleidung für den Bottich	Panel frontal cuba
11	421190004900			•	Pannello frontale vasca	Tub front panel	Panneau frontal cuve	Frontverkleidung für den Bottich	Panel frontal cuba
12	421150010600	•			Anello inferiore fissaggio vasca	Tub lower fastening ring	Anneau inférieur fixation cuve	Unterer Befestigungsring für den Bottich	Anillo inferior cierre cuba
12	421150011600		•		Anello inferiore fissaggio vasca	Tub lower fastening ring	Anneau inférieur fixation cuve	Unterer Befestigungsring für den Bottich	Anillo inferior cierre cuba
12	421150010400			•	Anello inferiore fissaggio vasca	Tub lower fastening ring	Anneau inférieur fixation cuve	Unterer Befestigungsring für den Bottich	Anillo inferior cierre cuba
13	50 851000219	•	•	•	Elettrovalvola vapore completa L145 R4	Complete steam solenoid valve L145 R4	Vanne solénoïde vapeur complete L145 R4	Komplettes Dampfmagnetventil L145 R4	Válvula solenoide vapor completa L145 R4
13	50 851000218	•	•	•	Bobina 230V Z534A	Coil 230V Z534A	Bobine 230V Z534A	Spule 230V Z534A	Bobina 230V Z534A
14	50 GI 801028	•	•	•	Nipplo porta valvola	Valve holding nipple	Porte vanne	Ventilträgnippel	Boquilla porta valvola
15	50 GI 801092	•	•	•	Tappo supporto iniettore	Support plug for steam injector	Bouchon porte injecteur vapeur	Stopfen für Einspritzerträger	Tapón soporte inyector vapor
16	50801000867	•	•	•	Iniettore vapore	Steam injector	Injecteur vapeur	Dampfeinspritzer	Inyector de vapor
17	50 GI 801111	•	•	•	Tubo vapore	Steam hose	Flexible vapeur	Dampfschlauch	Tubo de vapor

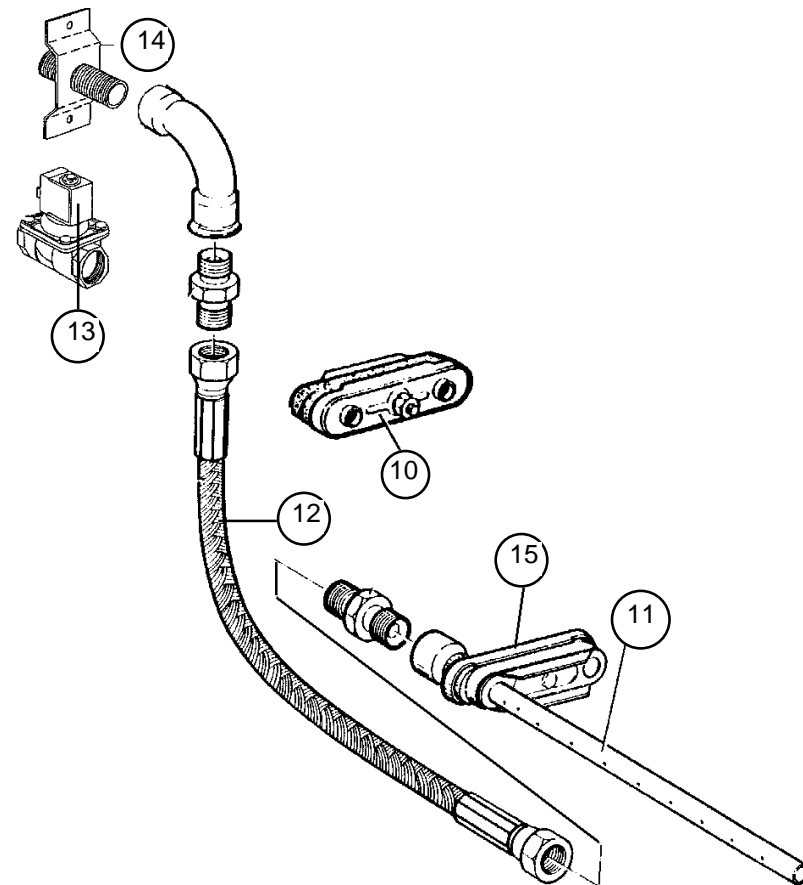
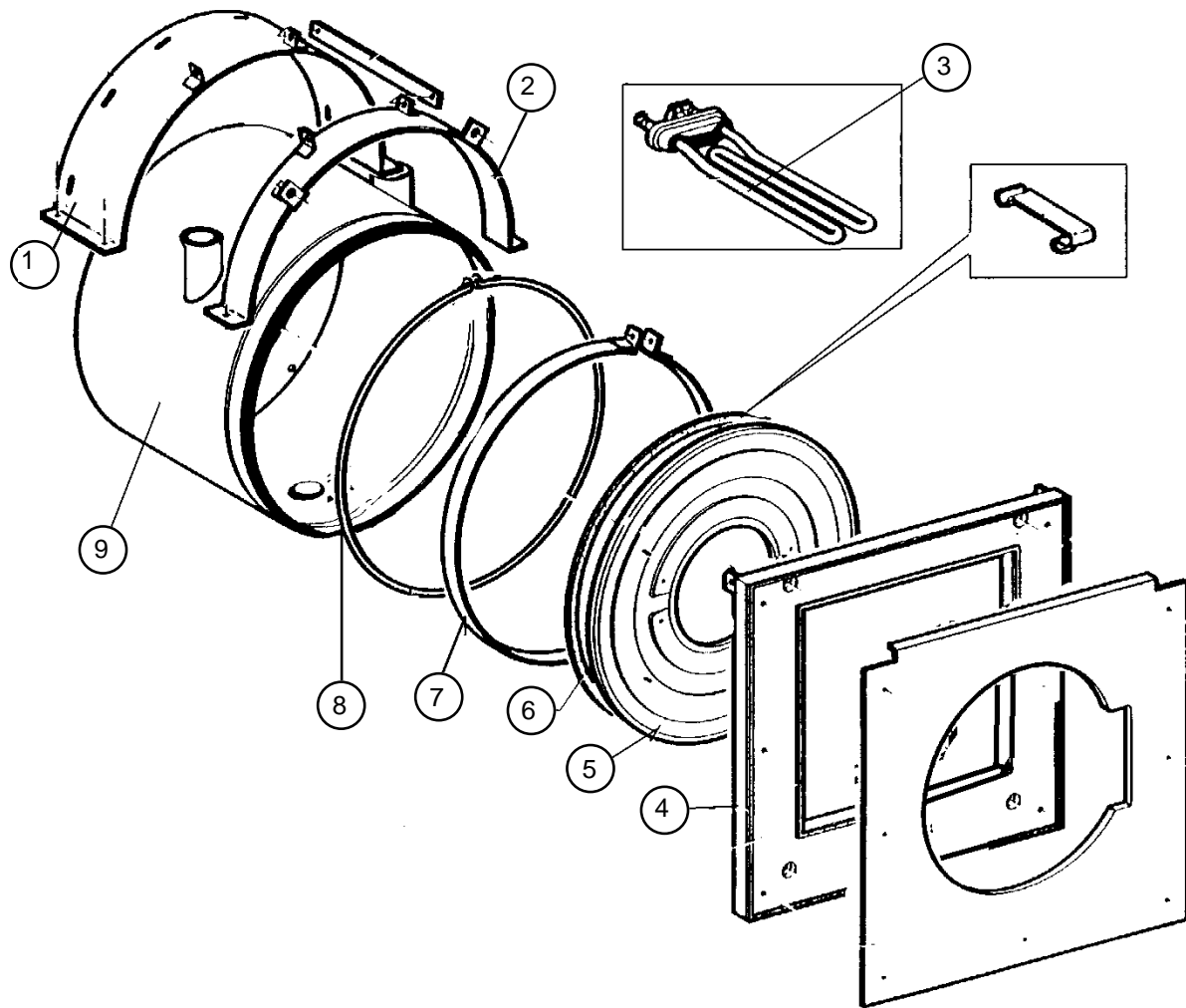

F/8-11-18-23-26-33/6



F/8-11-18-23-26-33/6

Pos.	Mod.	23 26 33	Descrizione	Description	Déscription	Beschreibung	Descripción
1	421150013400	• •	Anello superiore fissaggio vasca	Tub upper fastening ring	Anneau supérieur fixation cuve	Oberer Haltering für den Bottich	Anillo superior de cierre cuba
1	421150012300	•	Anello superiore fissaggio vasca	Tub upper fastening ring	Anneau supérieur fixation cuve	Oberer Haltering für den Bottich	Anillo superior de cierre cuba
2	421150013500	• •	Anello di fissaggio frontale	Front fastening ring	Anneau de fixation frontal	Vorderer Haltering	Anillo de cierre delantero
2	421150012400	•	Anello di fissaggio frontale	Front fastening ring	Anneau de fixation frontal	Vorderer Haltering	Anillo de cierre delantero
3	422090011601	• • •	Resistenza 1400W/220V	Heating element 1400W/220V	Résistance 1400W/220V	Heizwiderstand 1400W/220V	Resistencia 1400W/220V
3	50 GI 851112	• • •	Resistenza 2000W/220V/240V	Heating element 2000W/220V/240V	Résistance 2000W/220V/240V	Heizwiderstand 2000W/220V/240V	Resistencia 2000W/220V
3	50 GI 851113	• • •	Resistenza 3000W/220V	Heating element 3000W/220V	Résistance 3000W/220V	Heizwiderstand 3000W/220V	Resistencia 3000W/220V
3	422090005000	• • •	Resistenza 4000W/380V	Heating element 4000W/380V	Résistance 4000W/380V	Heizwiderstand 4000W/380V	Resistencia 4000W/220V
4	421113295600	• •	Pannello frontale completo	Complete front panel	Panneau frontal complet	Komplette Frontverkleidung	Panel delantero completo
4	421113294500	•	Pannello frontale completo	Complete front panel	Panneau frontal complet	Komplette Frontverkleidung	Panel delantero completo
5	421380000100	• •	Pannello frontale vasca	Tub front panel	Panneau frontal cuve	Frontverkleidung des Bottichs	Panel delantero de la cuba
5	421310000200	•	Pannello frontale vasca	Tub front panel	Panneau frontal cuve	Frontverkleidung des Bottichs	Panel delantero de la cuba
6	422230007800	• •	Guarnizione pannello frontale	Front panel gasket	Joint panneau frontal cuve	Dichtung für Frontverkleidung	Junta delantera panel cuba
6	422310000100	•	Guarnizione pannello frontale	Front panel gasket	Joint panneau frontal cuve	Dichtung für Frontverkleidung	Junta delantera panel cuba
7	421370000800	• •	Anello di fissaggio largo	Large fastening ring	Anneau large de fixation cuve	Breiter Haltering	Anillo ancho
7	421310000502	•	Anello di fissaggio largo	Large fastening ring	Anneau large de fixation cuve	Breiter Haltering	Anillo ancho
8	422380001100	• •	Anello di fissaggio stretto	Small fastening ring	Anneau étroit de fixation cuve	Enger Haltering	Anillo estrecho
8	422310001000	•	Anello di fissaggio stretto	Small fastening ring	Anneau étroit de fixation cuve	Enger Haltering	Anillo estrecho
9	421190020100	•	Vasca	Tub	Cuve	Bottich	Cuba
9	421190021400	•	Vasca	Tub	Cuve	Bottich	Cuba
9	421190021100	•	Vasca	Tub	Cuve	Bottich	Cuba
10	50 GI 801093	• • •	Tappo foro silicone stretto	Silicone plug wih hole	Bouchon trou silicone étroit	Silikonstopfen mit Loch	Tapón de silicona con orificio
11	50 801000868	• • •	Iniettore vapore	Steam injector	Injecteur vapeur	Dampfeinspritzer	Inyector de vapor
12	50 GI 801111	•	Tubo vapore	Steam hose	Flexible vapeur	Dampfschlauch	Tubo de vapor
13	50 851000219	• • •	Elettrovalvola vapore completa L145 R4	Complete steam solenoid valve L145 R4	Vanne solénoide vapeur complète L145 R4	Komplettes Dampfmagnetventil L145 R4	Válvula solenoide vapor completa L145 R4
13	50 851000218	• • •	Bobina 230V Z534A	Coil 230V Z534A	Bobine 230V Z534A	Spule 230V Z534A	Bobina 230V Z534A
14	50 GI 801028	• • •	Nipplo porta valvola	Valve holding nipple	Porte vanne	Ventilträgnippel	Boquilla porta válvula
15	50 GI 801092	• • •	Tappo supporto iniettore	Support plug for steam injector	Bouchon porte injecteur vapeur	Stopfen für Einspritzerträger	Tapón soporte inyector vapor

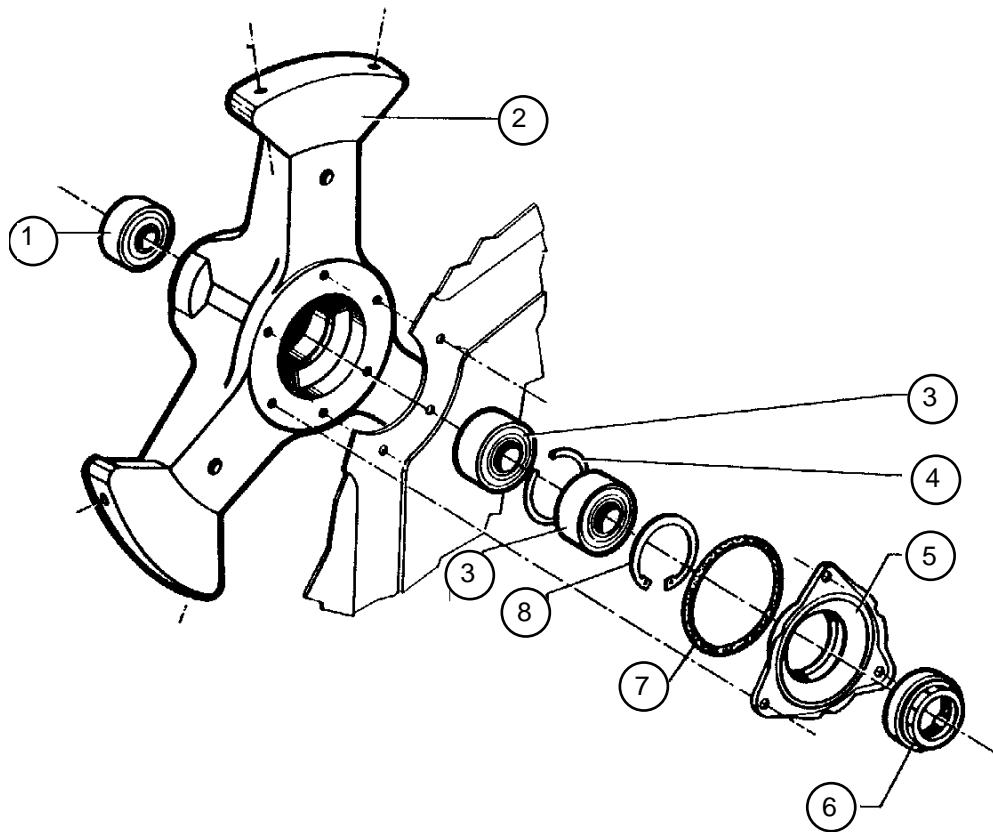

**F/8-11-18-23-26-33/7**

Pos.	Mod.	8	11	18	Descrizione	Description	Déscription	Beschreibung	Descripción
1	422150000102	•	•		Cuscinetto 6306-2z	Bearing 6306-2z	Roulement 6306-2z	Lager 6306-2z	Cojinete 6306-2z
1	422160000102		•		Cuscinetto 6308-2z	Bearing 6308-2z	Roulement 6308-2z	Lager 6308-2z	Cojinete 6308-2z
2	421150010100	•	•		Sede cuscinetti	Bearing house	Palier	Lagersitz	Caja de cojinetes
2	421160010100		•		Sede cuscinetti	Bearing house	Palier	Lagersitz	Caja de cojinetes
3	422150000103	•	•		Cuscinetto 6307-2z	Bearing 6307-2z	Roulement 6307-2z	Lager 6307-2z	Cojinetes 6307-2z
3	422160000103		•		Cuscinetto 6309-2z	Bearing 6309-2z	Roulement 6309-2z	Lager 6309-2z	Cojinetes 6309-2z
4	422120003000	•	•		Anello elastico tipo B DIN7993 RB80	Spring ring - type B DIN7993 RB80	Ressort circlips type B DIN7993 RB80	Federring Typ B DIN7993 RB80	Anillo elástico tipo B DIN 7993 RB80
4	422120003100		•		Anello elastico tipo B DIN7993 RB80	Spring ring - type B DIN7993 RB80	Ressort circlips type B DIN7993 RB80	Federring Typ B DIN7993 RB80	Anillo elástico tipo B DIN 7993 RB80
5	421170000100	•	•		Piastra di chiusura	Seal plate	Plaque d'étanchéité	Dichtungsplatte	Placa de estanqueidad
5	421190000100		•		Piastra di chiusura	Seal plate	Plaque d'étanchéité	Dichtungsplatte	Placa de estanqueidad
6	422170000300	•	•		Anello di chiusura	Seal ring	Baque d'étanchéité	Dichtungsring	Anillo de estanqueidad
6	422190000300		•		Anello di chiusura	Seal ring	Baque d'étanchéité	Dichtungsring	Anillo de estanqueidad
7	422170000200	•	•	•	O-ring 128x6	O-ring 128x6	O-ring 128x6	O-Ring 128x6	O-ring 128x6
8	422120002800	•	•		Anello elastico tipo J 80 DIN 472	Spring ring - type J 80 DIN 472	Ressort circlips type J 80 DIN 472	Federring Typ J 80 DIN 472	Anillo elástico tipo J 80 DIN 472
8	422120002900		•		Anello elastico tipo J 80 DIN 472	Spring ring - type J 80 DIN 472	Ressort circlips type J 80 DIN 472	Federring Typ J 80 DIN 472	Anillo elástico tipo J 80 DIN 472

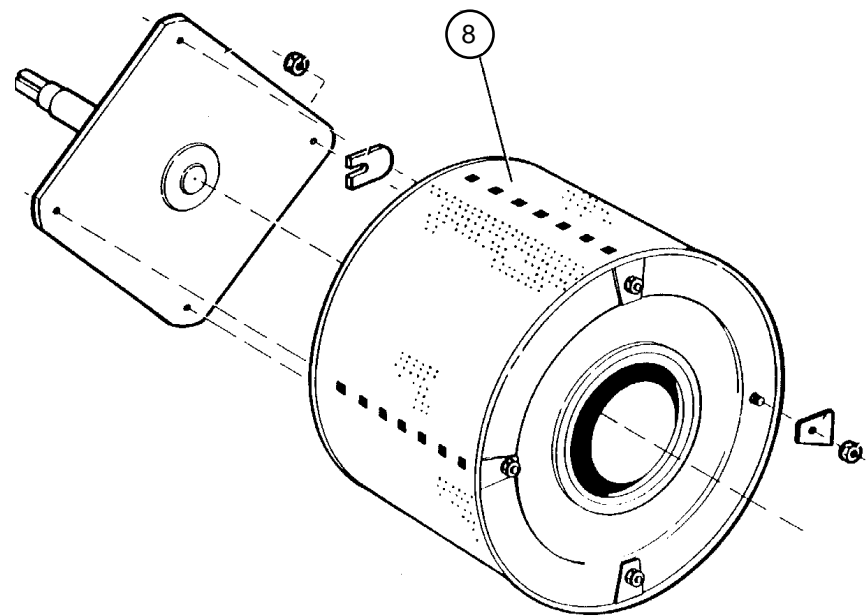
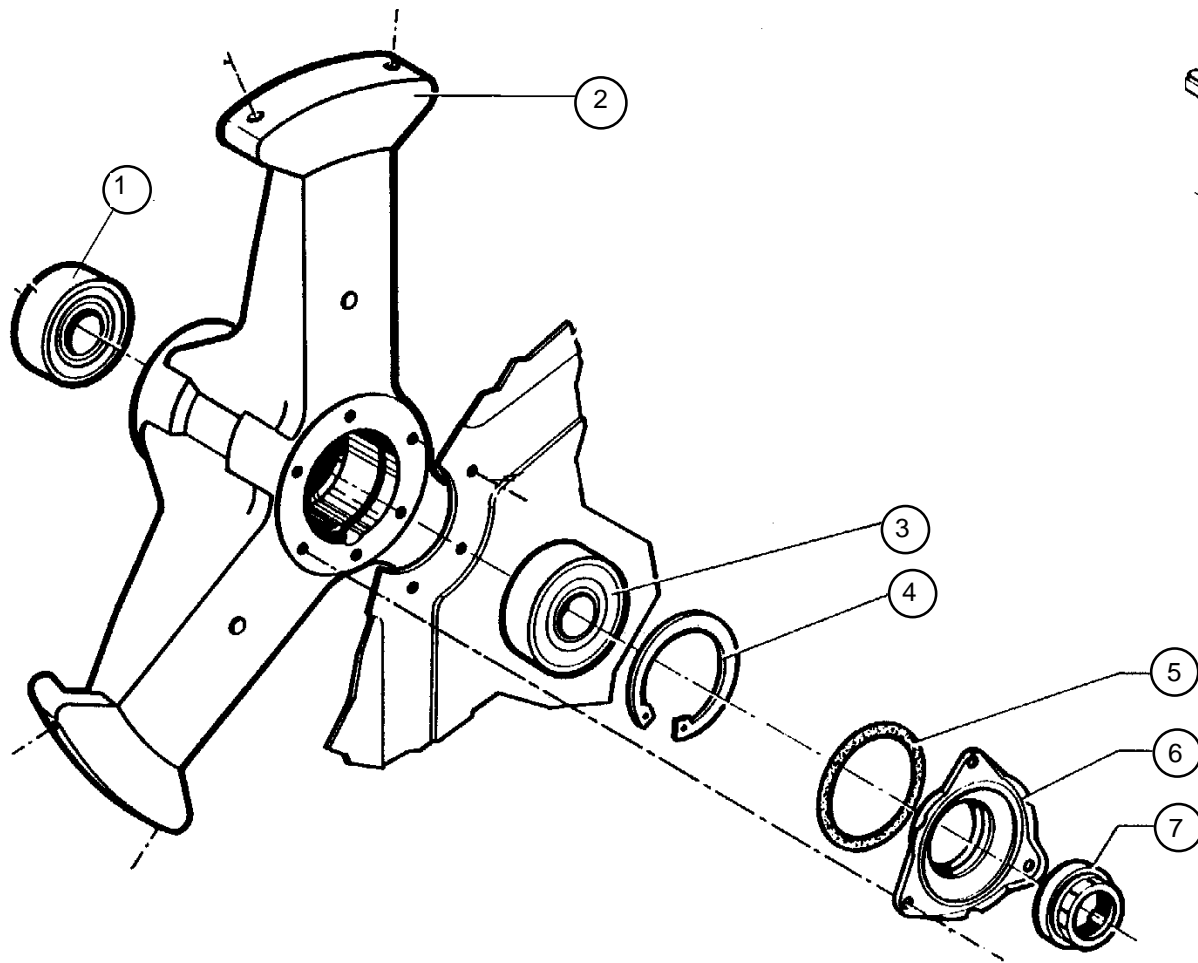

**F/8-11-18-23-26-33/8**

Pos.	Mod.	23 26 33	Descrizione	Description	Déscription	Beschreibung	Descripción
1	422120002400	• •	Cuscinetti 6310-2z	Bearings 6310-2z	Roulements à billes 6310-2z	Lager 6310-2z	Cojinetes 6310-2z
2	421390000601	• •	Sede cuscinetti	Bearing housing	Palier	Lagersitz	Caja de cojinetes
3	422120000400	• •	Cuscinetti 6311-2z/c3	Bearings 6311-2z/c3	Roulements à billes 6311-2z/c3	Lager 6311-2z/c3	Cojinetes 6311-2z
4	422120000600	• •	Anello elastico J120 DIN 472	Spring ring J120 DIN 472	Ressort circlips J120 DIN 472	Federring J120 DIN 472	Anillo elástico J120 DIN 472
5	422170000200	• •	O-ring 128x6	O-ring 128x6	O-ring 128x6	O-Ring 128x6	O-ring 128x6
6	421190000100	• •	Piastra di chiusura	Seal plate	Plaque d'étanchéité	Dichtungsplatte	Placa de estanqueidad
7	422190000300	• •	Anello di chiusura	Seal ring	Bague d'étanchéité	Dichtungsring	Anillo de estanqueidad
8	421230000600	•	Cesto + albero	Drum + shaft	Tambour + axe	Trommel + Welle	Tambor + eje
8	421230001000	•	Cesto + albero	Drum + shaft	Tambour + axe	Trommel + Welle	Tambor + eje
8	421230000800	•	Cesto + albero	Drum + shaft	Tambour + axe	Trommel + Welle	Tambor + eje

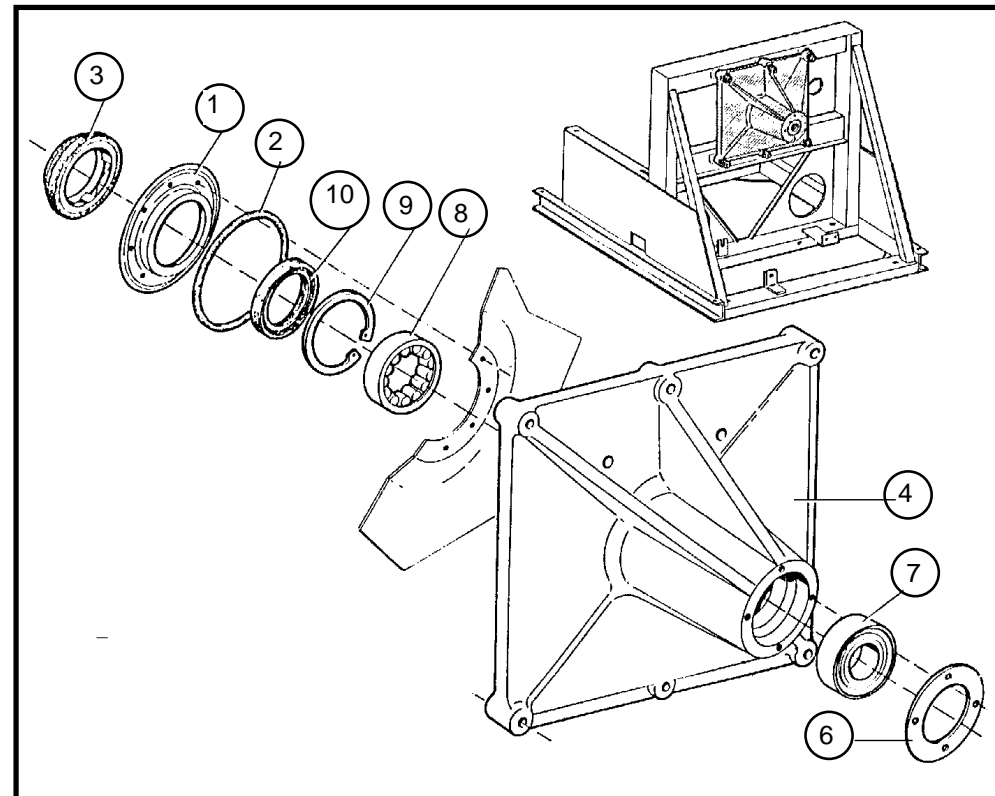
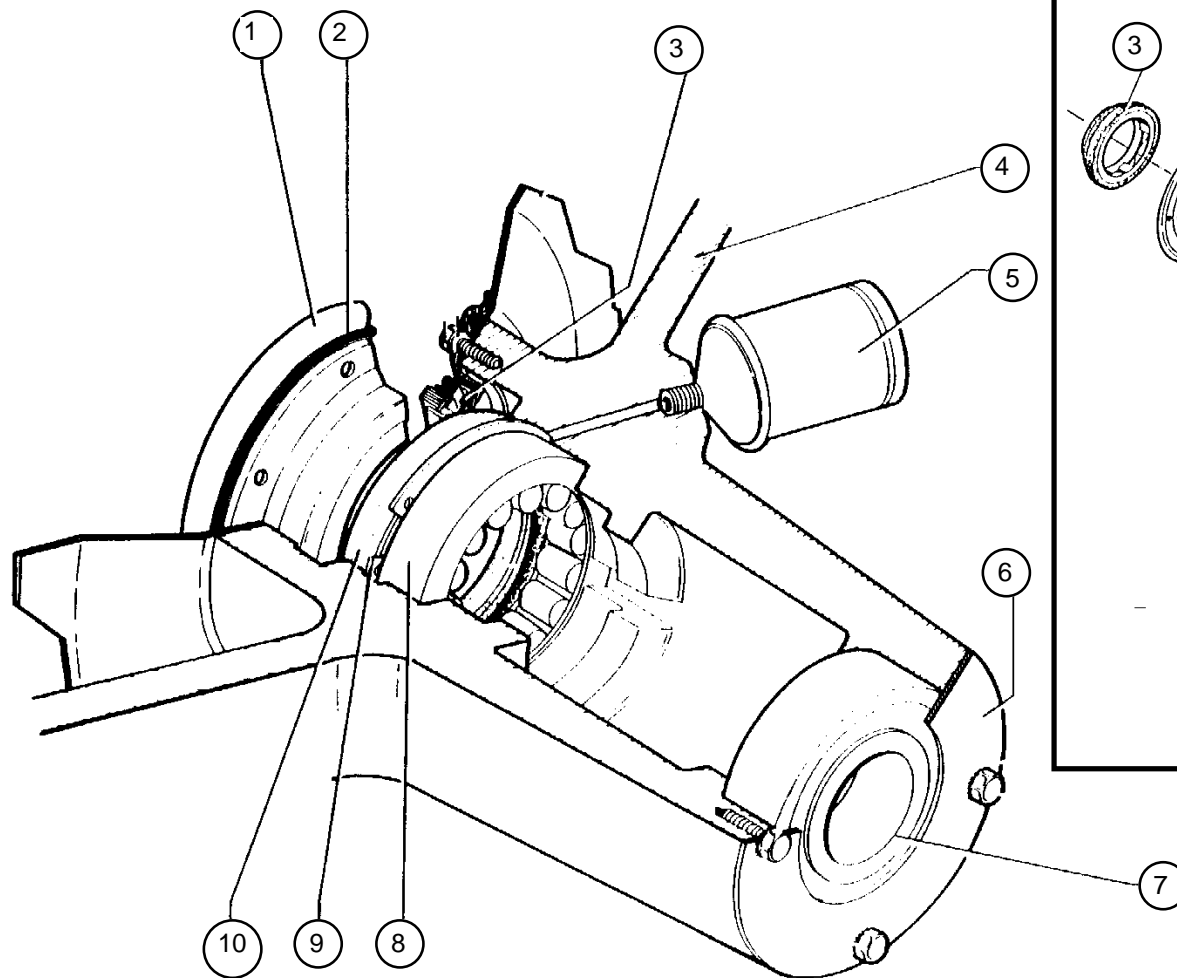

## F/8-11-18-23-26-33/9

Pos.	Mod.	33	Descrizione	Description	Déscription	Beschreibung	Descripción
1	421310003500	•	Piastra di chiusura	Seal plate	Plaque d'étanchéité	Dichtungsplatte	Placa de estanqueidad
2	422310003600	•	O-Ring 174,3 x 5,7	O-ring 174,3 x 5,7	O-ring 174,3 x 5,7	O-Ring 174,3 x 5,7	O-Ring 174,3 x 5,7
3	50 GI 530023	•	Anello di chiusura 76.62/92-130-20 N8	Seal ring 76.62/92-130-20 N8	Baquet d'étanchéité 76.62/92-130-20 N8	Dichtungsring 76.62/92-130-20 N8	Anillo de estanqueidad 76.62/92-130-20 N8
4	422120000100	•	Sede cuscinetti	Bearing housing	Palier	Lagersitz	Caja de cojinetes
5	422120000200	•	Flacone grasso	Grease box	Flacon de graisse	Fettbehälter	Recipiente grasa
6	421120000300	•	Piastra chiusura sede cuscinetti	Bearing housing cover plate	Plaque fermeture palier	Abdeckplatte für Lager	Placa cierre caja de cojinetes
7	422120000400	•	Cuscinetti 6311-2z/c3	Bearings 6311-2z/c3	Roulements à billes 6311-2z/c3	Lager 6311-2z/c3	Cojinete 6311-2z/c3
8	422120000500	•	Cuscinetto MU 213 ELP	Bearing MU 213 ELP	Roulement à billes MU 213 ELP	Lager MU 213 ELP	Cojinete MU 213 ELP
9	422120000600	•	Anello elastico J 120 DIN 472	Elastic ring J 120 DIN 472	Ressort circlips J 120 DIN 472	Federring J 120 DIN 472	Anillo elástico J 120 DIN 472
10	422120000700	•	Paragrasso 85 x 120 x 12 DIN 3760a	Grease guard 85 x 120 x 12 DIN 3760a	Arrêt graisse 85 x 120 x 12 DIN 3760a	Fettschutz 85 x 120 x 12 DIN 3760a	Para grasa 85 x 120 x 12 DIN 3760a

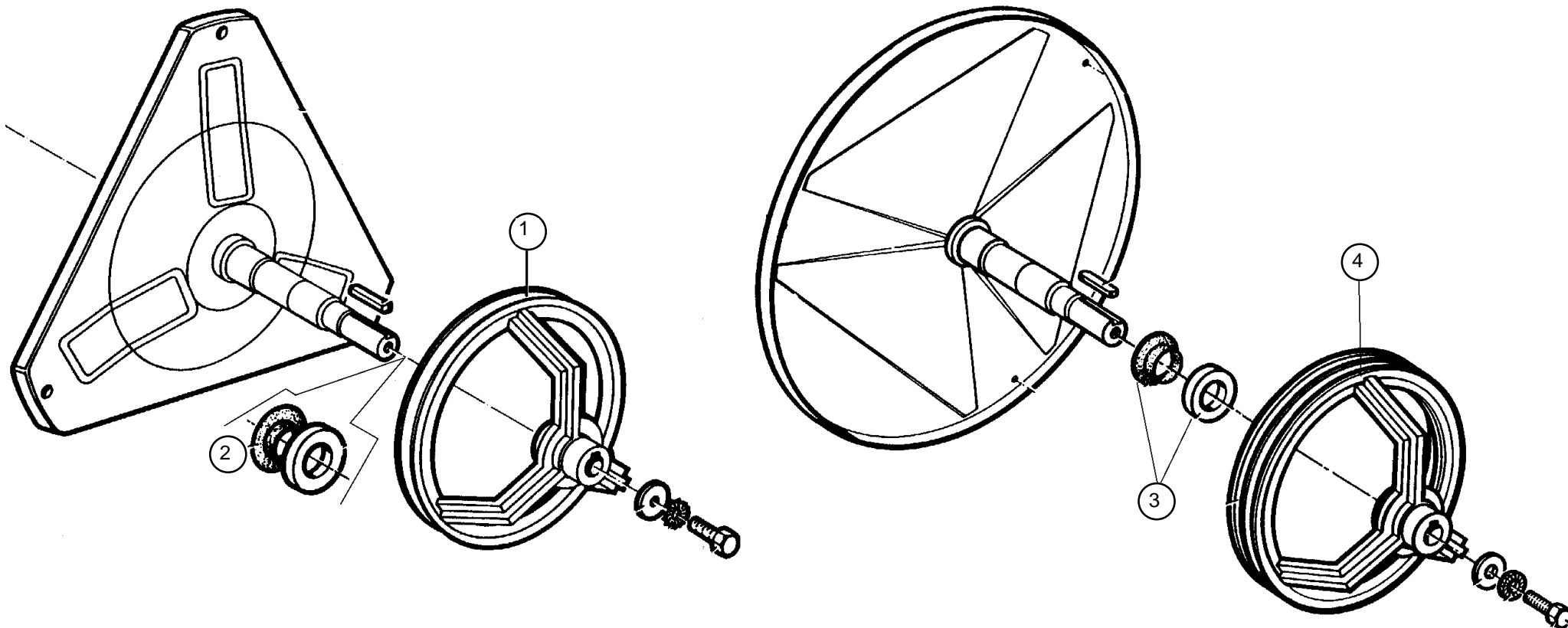

F/8-11-18-23-26-33/10

Pos.	Mod.	8	11	18	Descrizione	Description	Déscription	Beschreibung	Descripción
1	422260007100	•	•		Puleggia 280 mm 1SPZ 28h7	Pulley 280 mm 1SPZ 28h7	Poulie 280 mm 1SPZ 28h7	Riemenscheibe 280 mm 1SPZ 28h7	Polea 280 mm 1SPZ 28h7
2	422170000400	•	•		Controanello	Counterring	Contre bague	Gegenring	Contraanillo
3	422190000400		•		Controanello	Counterring	Contre-bague	Gegenring	Contraanillo
4	422260007000		•		Puleggia 280 mm 2SPZ 38h7	Pulley V 280 mm 2SPZ 38h7	Poulie tambour 280 mm 2SPZ 38h7	Riemenscheibe V 280 mm 2SPZ 38h7	Polea 280 mm 2SPZ 38h7

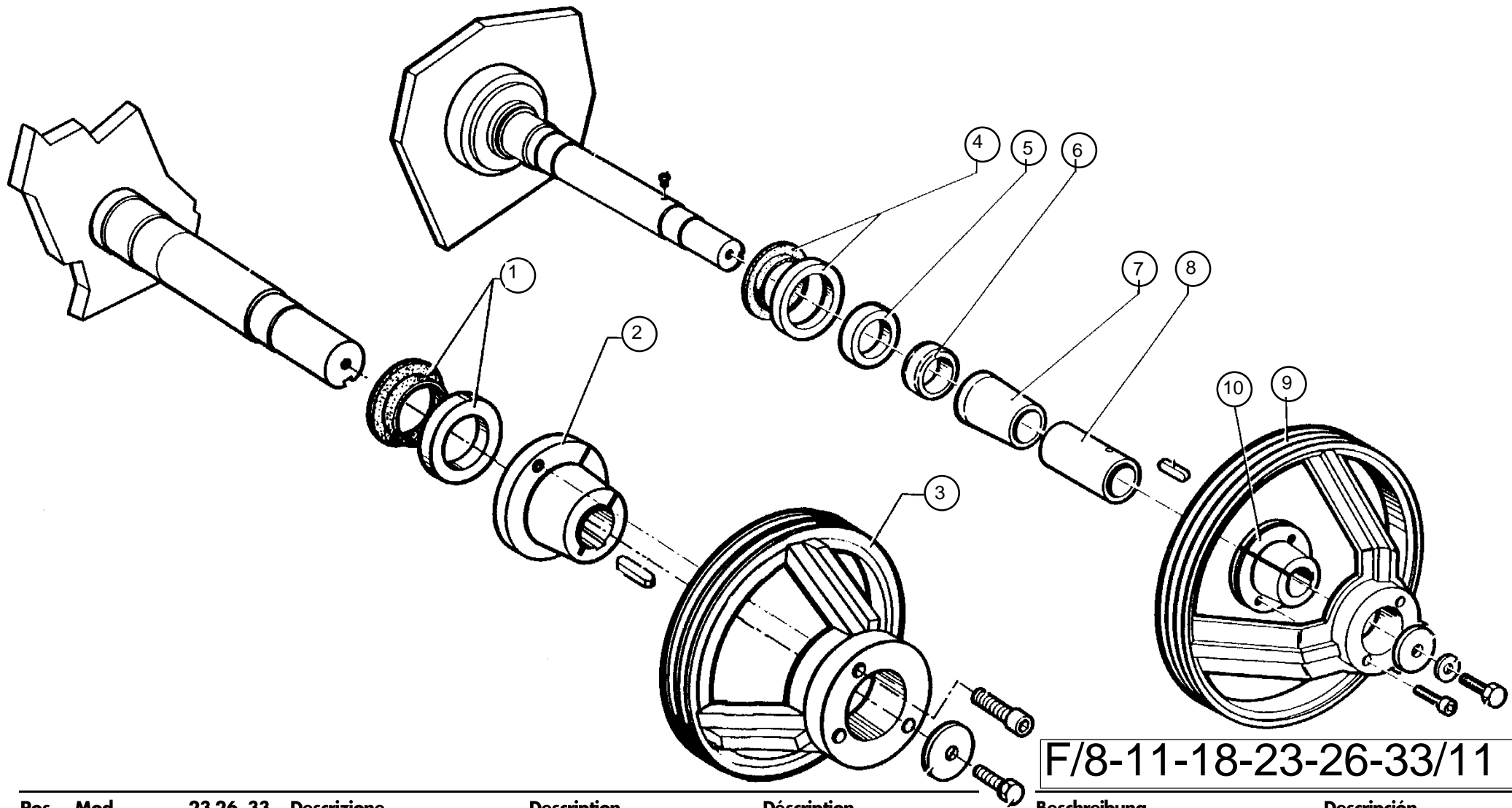

**F/8-11-18-23-26-33/11**

Pos.	Mod.	23 26 33	Descrizione	Description	Déscription	Beschreibung	Descripción
1	422190000400	• •	Controanello	Counterring	Contre-bague	Gegenring	Contraanillo
2	422390000501	• •	Anello albero/puleggia 48H7	Shaft/pulley ring 48H7	Manchon pour poulie à gorge 48H7	Ring für Welle-Riemenscheibe 48H7	Anillo eje/polea 48H7
3	422260010001	• •	Puleggia 280 mm 2SPZ	Pulley 280mm 2SPZ	Poulie 280mm 2SPZ	Riemenscheibe 280mm 2SPZ	Polea 280 mm 2SPZ
4	422320000800	•	Controanello	Counterring	Contre bague	Gegenring	Contraanillo
5	421320000900	•	Paragrasso		Grease guard	Arrêt - graisse Fettschutz	Para grasa
6	422120000500	•	Cuscinetto NV213 ECP	Bearing NV213 ECP	Roulement NV213 ECP	Lager NV213 ECP	Cojinete NV213 ECP
7	421320001000	•	Tubo conico di mezzo	Conical intermediate pipe	Tube conique intermédiaire	Konisches Zwischenrohr	Tubo cónico intermedio
8	421320001100	•	Tubo cilindrico di mezzo	Cylindric intermediate pipe	Tube cylindrique intermédiaire	Zylinderförmiges Zwischenrohr	Tubo cilindrico intermedio
9	422260009001	•	Puleggia 450 3spz	Pulley 450 3spz	Poulie 450 3spz	Riemenscheibe 450 3spz	Polea 450 3spz
10	422120000901	•	Anello albero/puleggia	Shaft/pulley ring	Manchon pour poulie à gorge	Ring für Welle-Riemenscheibe	Anillo eje/polea

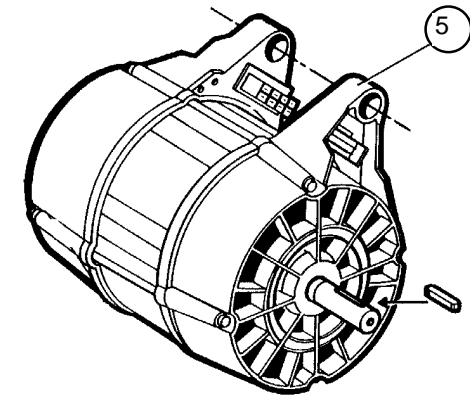
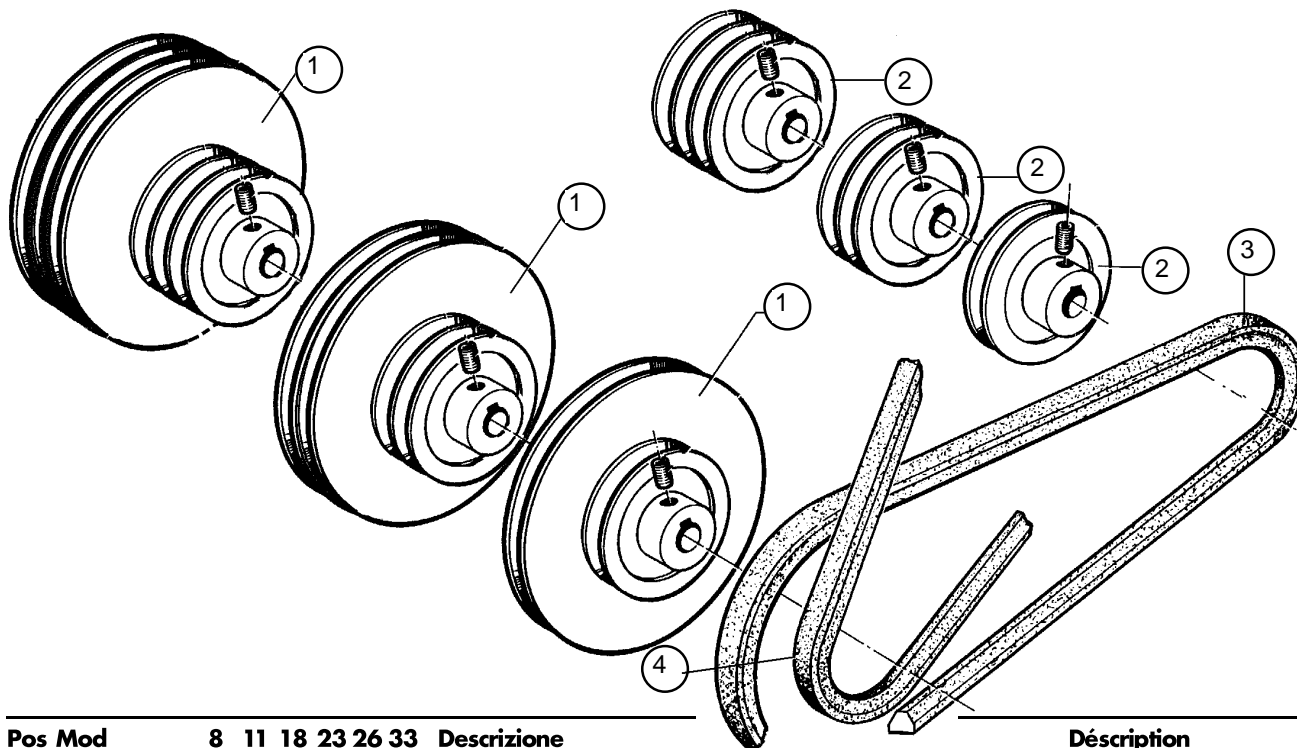

**F/8-11-18-23-26-33/12**

Pos	Mod	8	11	18	23	26	33	Descrizione	Déscription	Beschreibung	Descripción	
1	422260008500	•	•					Puleggia 165/97 2SPZ 19h7 50Hz	Pulley 165/97 2SPZ 19h7 50Hz	Poulie 165/97 2SPZ 19h7 50Hz	Riemenscheibe 165/97 2SPZ 19h7 50Hz	Polea 165/97 2SPZ 19h7 50Hz
1	422260008600	•	•					Puleggia 165/97 2SPZ 19h7 60Hz	Pulley 165/97 2SPZ 19h7 60Hz	Poulie 165/97 2SPZ 19h7 60Hz	Riemenscheibe 165/97 2SPZ 19h7 60Hz	Polea 165/97 2SPZ 19h7 60Hz
1	422260008000			•				Puleggia 165/94mm 50 Hz	Pulley 165/94mm 50 Hz	Poulie 165/94mm 50 Hz	Riemenscheibe 165/94mm 50 Hz	Polea 165/94mm 50 Hz
1	422260008100			•				Puleggia 165/75mm 60 Hz	Pulley 165/75mm 60 Hz	Poulie 165/75mm 60 Hz	Riemenscheibe 165/75mm 60 Hz	Polea 165/75mm 60 Hz
2	422260006800	•	•					Puleggia 90 1 SPZ 19h7 50-60 Hz	Pulley 90 1 SPZ 19h7 50-60 Hz	Poulie 90 1 SPZ 19h7 50-60 Hz	Riemenscheibe 90 1 SPZ 19h7 50-60 Hz	Polea 90 1 SPZ 19h7 50-60 Hz
2	422390001200			•				Puleggia 84mm 2SPZ 24h7	Pulley 84mm 2SPZ 24h7	Poulie 84mm 2SPZ 24h7	Riemenscheibe 84mm 2SPZ 24h7	Polea 84mm 2SPZ 24h7
2	422260010500			•	•			Puleggia motore 2SPZ	Motor pulley 2SPZ	Poulie moteur 2SPZ	Riemenscheibe für Motor 2SPZ	Polea motor 2SPZ
2	422260010600					•		Puleggia motore 3SPZ	Motor pulley 3SPZ	Poulie moteur 3SPZ	Riemenscheibe für Motor 3SPZ	Polea motor 3SPZ
3	422260009300	•	•					Cinghia XPZ 1037 lw	Belt XPZ 1037 lw	Courroie XPZ 1037 lw	Riemen XPZ 1037 lw	Correa XPZ 1037 lw
3	422260009400			•				Cinghia XPZ 1137 lw	Belt XPZ 1137 lw	Courroie XPZ 1137 lw	Riemen XPZ 1137 lw	Correa XPZ 1137 lw
4	422260007800	•	•					Cinghia SPZ 1462 lw 50 Hz	Belt SPZ 1462 lw 50 Hz	Courroie SPZ 1462 lw 50 Hz	Riemen SPZ 1462 lw 50 Hz	Correa SPZ 1462 lw 50 Hz
4	422260007900	•	•					Cinghia SPZ 1437 lw 60 Hz	Belt SPZ 1437 lw 60 Hz	Courroie SPZ 1437 lw 60 Hz	Riemen SPZ 1437 lw 60 Hz	Correa SPZ 1437 lw 60 Hz
4	422260009600			•				Cinghia SPZ 1565 lw 50Hz	Belt SPZ SPZ 1565 lw 50Hz	Courroie SPZ 1565 lw 50Hz	Riemen SPZ 1565 lw 50Hz	Correa SPZ 1565 lw 50Hz
4	422260008200			•				Cinghia SPZ 1537 lw 60Hz	Belt SPZ 1537 lw 60Hz	Courroie SPZ 1537 lw 60Hz	Riemen SPZ 1537 lw 60Hz	Correa SPZ 1537 lw 60Hz
4	422260004300			•	•			Cinghia XPZ 1700	Belt XPZ 1700	Courroie XPZ 1700	Riemen XPZ 1700	Correa XPZ 1700
4	422260008800			•				Cinghia XPZ 1750	Belt XPZ 1750	Courroie XPZ 1750	Riemen XPZ 1750	Correa XPZ 1750
5	422270011100	•						Motore	Spin motor	Moteur	Motor	Motor
5	422270011200		•					Motore	Wash motor	Moteur	Motor	Motor
5	422280000101			•				Motore ELMO CV 132 C/3229	Motor ELMO CV 132 C/3229	Moteur ELMO CV 132 C/3229	Motor ELMO CV 132 C/3229	Motor ELMO CV 132 C/3229
5	422280000401			•				Motore ELMO CV 132 C/2573	Motor ELMO CV 132 C/2573	Moteur ELMO CV 132 C/2573	Motor ELMO CV 132 C/2573	Motor ELMO CV 132 C/2573
5	422270013900			•	•			Motore 3kW FIBER EL6 + Inverter	Motor 3KW FIBER EL6 + Inverter	Moteur 3KW FIBER EL6 + Inverter	Motore 3kW FIBER EL6 + Inverter	Motore 3kW FIBER EL6 + Inverter
5	422270011500			•				Motore 4kW FIBER EL6 + Inverter	Motor 4KW FIBER EL6 + Inverter	Moteur 4KW FIBER EL6 + Inverter	Motor 4kW FIBER EL6 + Inverter	Motor 4kW FIBER EL6 + Inverter

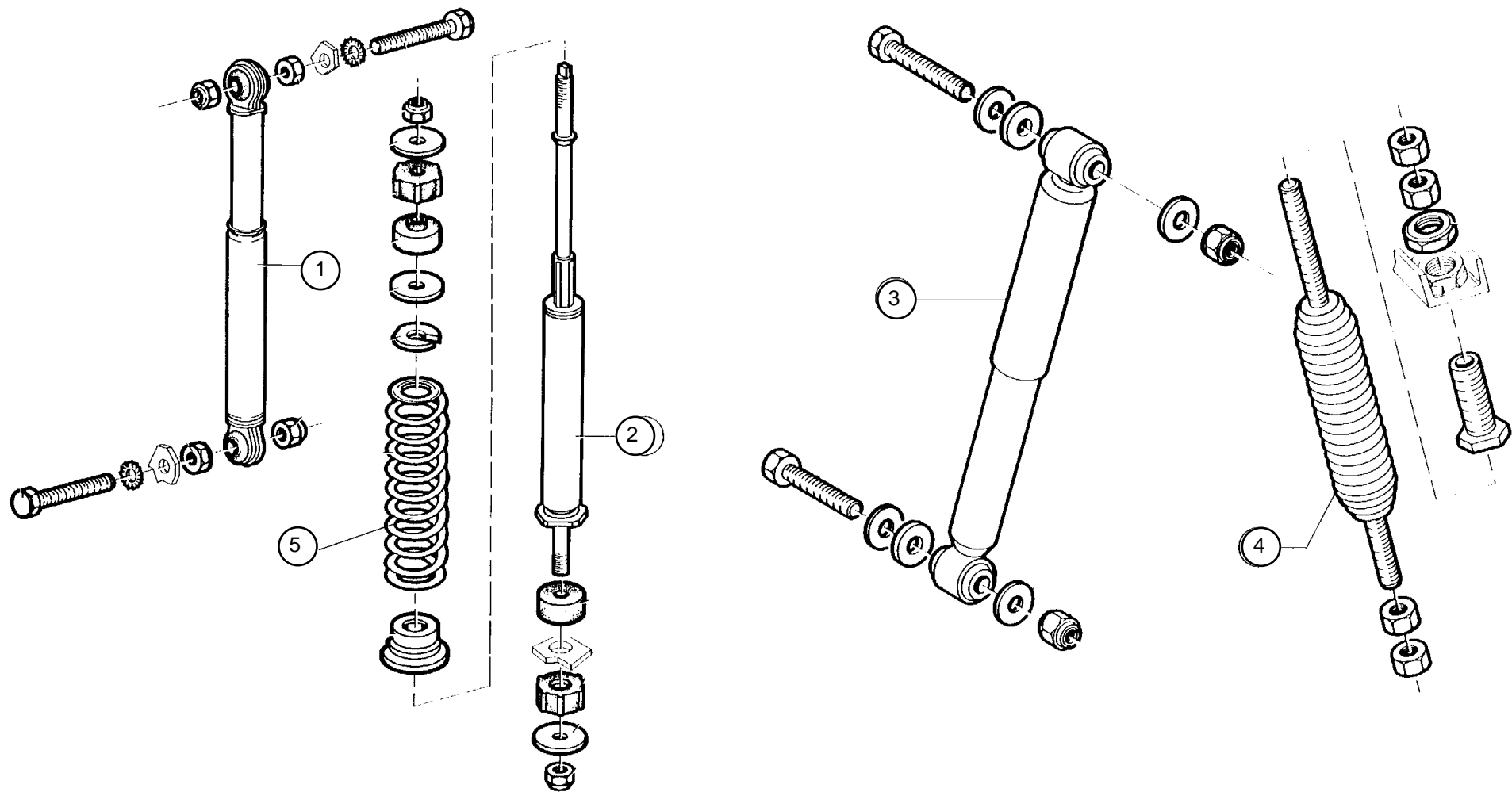

**F/8-11-18-23-26-33/13**

Pos.	Mod.	8	11	18	23	26	33	Descrizione	Description	Déscription	Beschreibung	Descripción
1	422470000500	•	•					Ammortizzatore ad aria	Air shock absorber	Amortisseur à air	Luftdämpfer	Amortiguador a aire
1	422470000400			•				Ammortizzatore ad aria	Air shock absorber	Amortisseur à air	Luftdämpfer	Amortiguador a aire
2	422470000102	•	•					Ammortizzatore a molla	Spring shock absorber	Amortisseur à ressort	Federdämpfer	Amortiguador a Resorte
2	422470000202			•				Ammortizzatore a molla	Spring shock absorber	Amortisseur à ressort	Federdämpfer	Amortiguador a Resorte
3	422470000800				•	•	•	Ammortizzatore MONROE tipo R1064	Shock absorber MONROE type R1064	Amortisseur MONROE type R1064	Dämpfer MONROE Typ R1064	Amortiguador MONROE tipo R 1064
4	422240004400					•		Sospensione a molla gialla	Yellow spring suspension	Suspension de ressort jaune	Gelbe Federaufhängung	Amortiguador de resorte amarillo
4	422240004500				•	•		Sospensione a molla bianca	White spring suspension	Suspension de ressort blanche	Weiße Federaufhängung	Amortiguador de resorte blanco
5	422470000101	•	•	•				Sospensione a molla ø 4,8	ø 4,8 spring suspension	Ressort suspension ø 4,8	Federaufhängung ø 4,8	Resorte amortiguador ø 4,8
5	522470000201			•				Sospensione a molla ø 5,5	ø 5,5 spring suspension	Ressort suspension ø 5,5	Federaufhängung ø 5,5	Resorte amortiguador ø 5,5



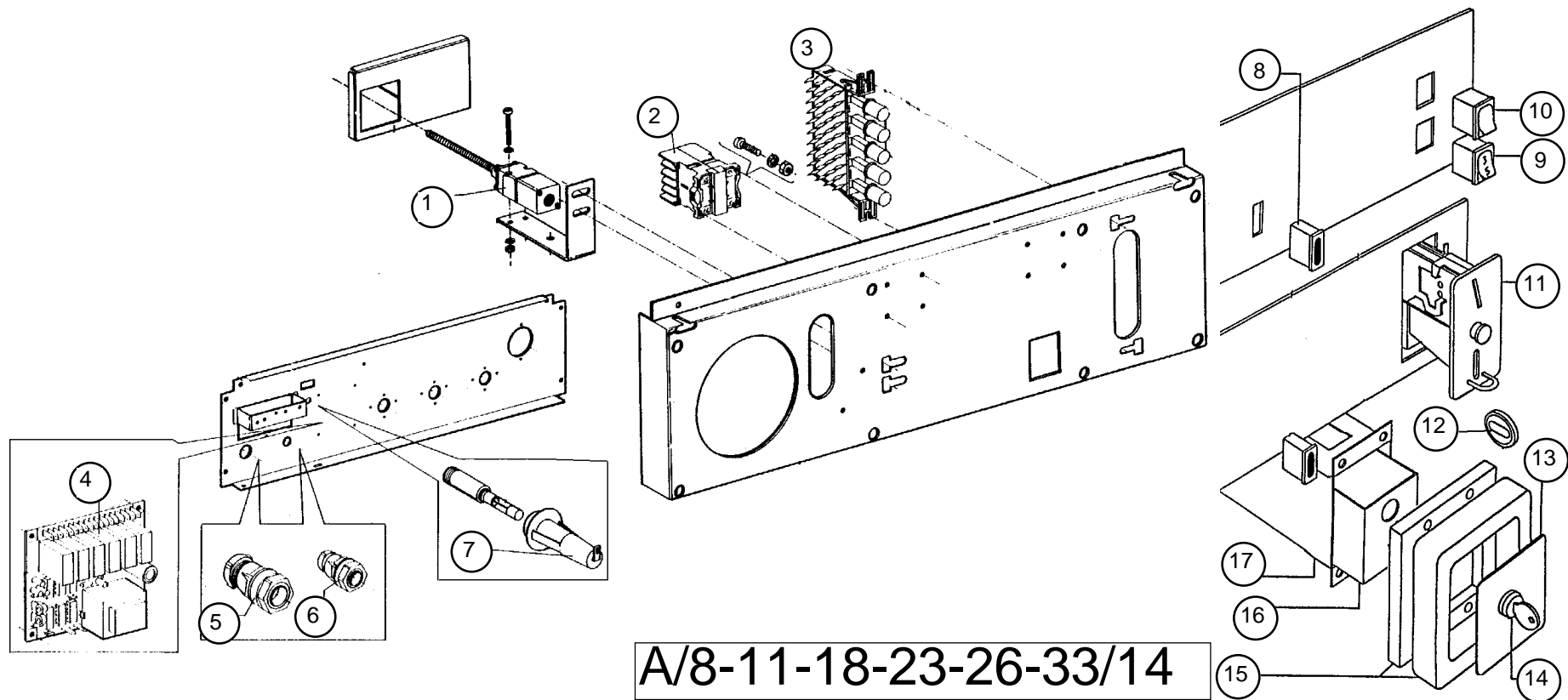

## A/8-11-18-23-26-33/14

Pos	Mod.	8	11	18	23	26	33	Descrizione	Description	Déscription	Beschreibung	Descripción
1	422090025500	•	•	•	•	•	•	Microinterruttore di sbilanciamento	Tilt microswitch	Microinterrupteur de débalancement	Unwuchtmikroschalter	Microinterruptor de desequilibrio
2	422090012400	•	•	•				Contattore CA2-EL 122M	Contacteur CA2-EL 122M	Contacteur CA2-EL 122M	Kontaktgeber CA2-EL 122M	Contacteur CA2-EL 122M
3	422090017500	•	•	•				Pulsantiera cicli	Cycle push-button panel	Clavier cycles	Druckknopf tafel für Arbeitszyklus	Panel botones de ciclos
4	422090023900	•	•	•				Scheda controllo centrifuga	Spin control print board	Carte contrôle essorage	Elektron.Kontrollkarte für das Schleudern	Ficha electr. control centrif.
5	54 GI 701235	•	•	•	•	•	•	Pressacavo PG21	Cable clamp PG21	Presse câble PG21	Kabelschelle PG21	Mordaza para cable PG21
6	50 GI 801236	•	•	•	•	•	•	Pressacavo PG16	Cable clamp PG16	Presse câble PG16	Kabelschelle PG16	Mordaza para cable PG16
7	422090020200	•	•	•	•	•	•	Porta fusibile	Fuse holder	Porte fusible	Sicherungshalter	Porta fusibile
8	50 GI 851142	•	•	•				Lampada ovale gialla	Oval yellow lamp	Lampe témoin jaune	Ovale gelbe Beleuchtung	Lámpara ovalada amarilla
9	50 GI 851145	•	•	•				Deviatore istantaneo verde	Green snapshot switch	Interrupteur déviateur vert	Grüner Rascher Abweiser	Interruptor desviador verde
10	50 GI 851146	•	•	•				Deviatore istantaneo rosso	Red switch	Interrupteur déviateur rouge	Roter Rascher Abweiser	Desviador rojo
11	50 GI 347004	•	•	•				Gettoniera GI	Coin meter GI	Monnayeur GI	Münzeinwurf GI	Contador de fichas GI
12	50 GI 347011	•	•	•				Gettoniera 2FF+10FF	Coin meter 2FF+10FF	Monnayeur 2FF+10FF	Münzeinwurf 2FF+10FF	Contador de fichas 2FF+10FF
13	50 GI 347014	•	•	•				Gettone GI	Coin GI	Jeton GI	Münze GI	Ficha GI
14	50 GI 185103	•	•	•				Frontalino cassetto gettoni	Coin meter front lid	Plaque frontale monnayeur	Frontplatte für Münzeinwurf	Tapa delantera contador fichas
15	50 GI 610029	•	•	•				Serratura gettoniera	Coin meter lock	Serrure monnayeur	Münzeinwurfverschluß	Cerradura contador de fichas
16	50 GI 185104	•	•	•				Cornice e spessore	Thickening frame	Corniche et épaisseur	Rahmen und Dicke	Cornisa y espesor
17	50 GI 185102	•	•	•				Contentitore gettoni	Coin box	Boîte à jetons	Münzenbehälter	Caja de fichas
18	50 GI 185101	•	•	•				Contentitore	Box	Boîte	Behälter	Caja

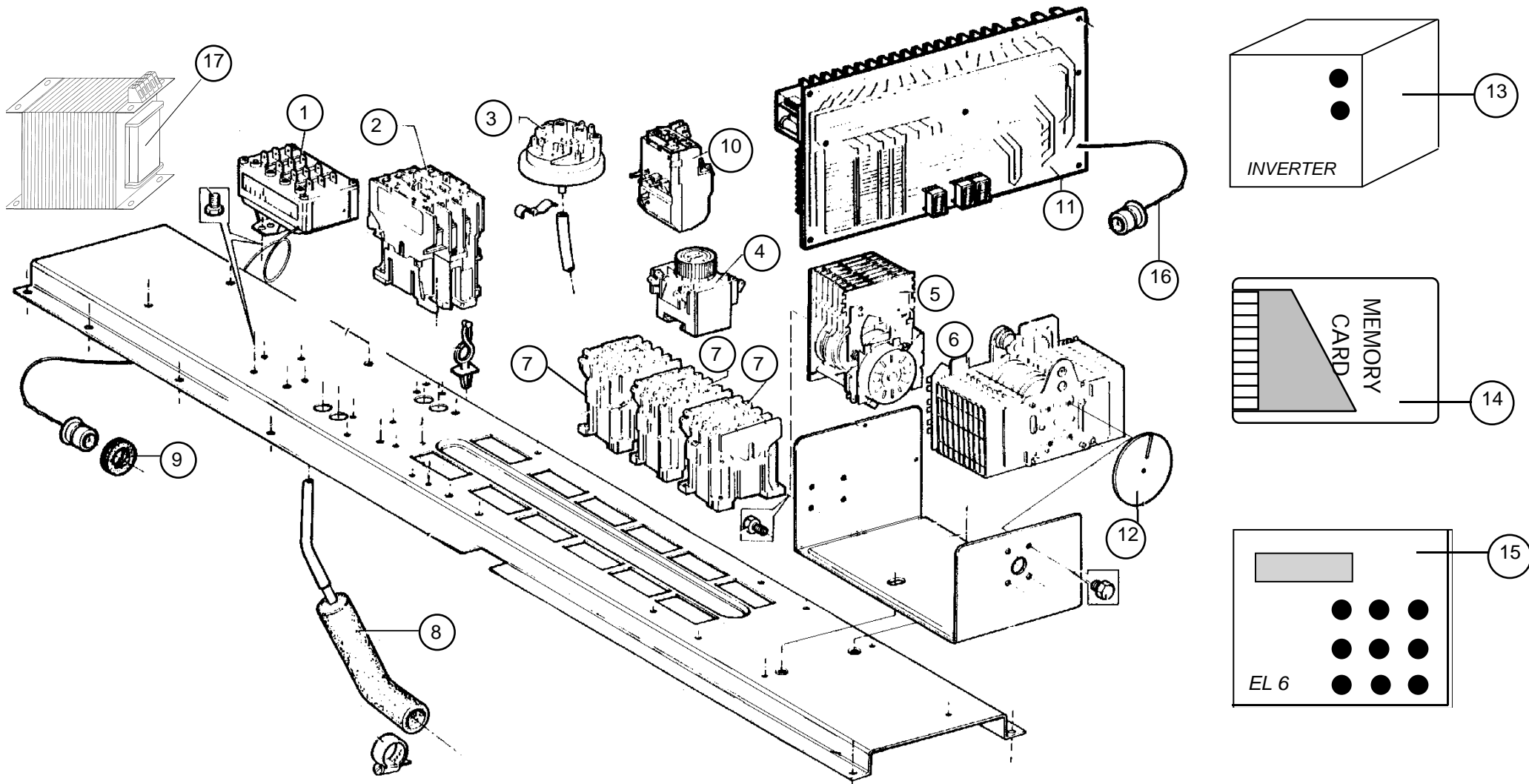

F/8-11-18-23-26-33/15

# F/8-11-18-23-26-33/15

Pos	Mod.	8	11	18	23	26	33	Descrizione	Description	Déscription	Beschreibung	Descripción
1	422090024300	•	•	•				Termostato 4 temperature	4-temp. thermostat	Thermostat 4 températures	4-Temperaturen-Thermostat	Termostato 4 temperaturas
2	422090004104	•	•	•				Contattore LC1D0901M5	Contacteur LC1D0901M5	Contacteur LC1D0901M5	Kontaktgeber LC1D0901M5	Contacteur LC1D0901M5
2	422090014802	•	•	•	•	•		Contattore LC1D1810M5	Contacteur LC1D1810M5	Contacteur LC1D1810M5	Kontaktgeber LC1D1810M5	Contacteur LC1D1810M5
2	422090014902	•	•	•	•	•		Contattore LC1D3210M5	Contacteur LC1D3210M5	Contacteur LC1D3210M5	Kontaktgeber LC1D3210M5	Contacteur LC1D3210M5
2	422090015002	•	•	•				Contattore LC1D5011M5	Contacteur LC1D5011M5	Contacteur LC1D5011M5	Kontaktgeber LC1D5011M5	Contacteur LC1D5011M5
2	422090017702	•	•	•				Contattore LC1D2510M5	Contacteur LC1D2510M5	Contacteur LC1D2510M5	Kontaktgeber LC1D2510M5	Contacteur LC1D2510M5
2	422090005602	•	•	•				Contattore LC1D4011M5	Contacteur LC1D4011M5	Contacteur LC1D4011M5	Kontaktgeber LC1D4011M5	Contacteur LC1D4011M5
3	422090000720	•	•	•				Pressostato EATON rif.1411180	Water level switch EATON ref.1411180	Pressostat EATON ref.1411180	Wasserstandregler EATON N°1411180	Presostato EATON N°1411180
4	422090010102	•	•	•				Ritardatore LA2DT49	Time delay switch LA2DT49	Contact de temporisation LA2DT49	Verzögerungskontakt LA2DT49	Contacteur retardador LA2DT49
4	422090010302	•	•	•				Ritardatore LA3DT49	Time delay switch LA3DT49	Contact de temporisation LA3DT49	Verzögerungskontakt LA3DT49	Contacteur retardador LA3DT49
5	422090001200	•	•	•				Inversore IO858 220V 50Hz	Reversing switch IO858 220V 50Hz	Inverseur IO858 220V 50Hz	Wendeschalter IO858 220V 50Hz	Invertidor IO858 220V 50Hz
5	422090001300	•	•	•				Inversore IO861 220V 60Hz	Reversing switch IO861 220V 60Hz	Inverseur IO861 220V 60Hz	Wendeschalter IO861 220V 60Hz	Invertidor IO861 220V 60Hz
6	422090010700	•	•	•				Programm. IO1134 220V 60Hz	Programmer IO1134 220V 60Hz	Programmeur IO1134 220V 60Hz	Programmschal. IO1134 220V 60Hz	Programador IO1134 220V 60Hz
6	422090010600	•	•	•				Programm. IO1126 220V 50Hz	Programmer IO1126 220V 50Hz	Programmeur IO1126 220V 50Hz	Programmschal. IO1126 220V 50Hz	Programador IO1126 220V 50Hz
7	422090004103	•	•	•				Contattore LC1-D09019M7	Contacteur LC1-D09019M7	Contacteur LC1-D09019M7	Kontaktgeber LC1-D09019M7	Contacteur LC1-D09019M7
8	422230011900	•	•	•				Tube camera d'aria+flessibile 750mm	Rub. elb., wat. lev. switch+hose 750mm	Coude pressostat	Gummiehb., Wasserstandreg.+Schlauch	Codo goma, presos+tubo 750mm
8	422230012700						•	Tube camera d'aria	Rubber elbow	Coude pressostat	Gummiehbogen	Codo de goma
8	422230003801				•	•		Tube camera d'aria	Rubber elbow	Coude pressostat	Gummiehbogen	Codo de goma
9	422251000400	•	•	•				Fissaggio per sensore termostato	Temp. control feeler seal	Pièces d'étanchéité thermostat	Befestigungsstück für Thermostatfühler	Sello sensor termostato
10	422090028500	•	•	•				Relé termico LR2-D1312/5,5-8A	Thermal relay LR2-D1312/5,5-8A	Disjoncteur LR2-D1312/5,5-8A	Therm. Relais LR2-D1312/5,5-8A	Relé termico LR2-D1312/5,5-8A
10	422090028300	•	•	•				Relé termico LR2-D1306/1-1,6A	Thermal relay LR2-D1306/1-1,6A	Disjoncteur LR2-D1306/1-1,6A	Therm. Relais LR2-D1306/1-1,6A	Relé termico LR2-D1306/1-1,6A
10	422090026400	•	•	•				Relé termico LR2-D1310/4-6A	Thermal relay LR2-D1310/4-6A	Disjoncteur LR2-D1310/4-6A	Therm. Relais LR2-D1310/4-6A	Relé termico LR2-D1310/4-6A
10	422090026300	•	•	•				Relé termico LR2-D1308/2,5-4A	Thermal relay LR2-D1308/2,5-4A	Disjoncteur LR2-D1308/2,5-4A	Therm. Relais LR2-D1308/2,5-4A	Relé termico LR2-D1308/2,5-4A
10	422090028400	•	•	•				Relé termico LR2-D1307/1,6-5,5A	Thermal relay LR2-D1307/1,6-5,5A	Disjoncteur LR2-D1307/1,6-5,5A	Therm. Relais LR2-D1307/1,6-5,5A	Relé term. LR2-D1307/1,6-5,5A
10	422090026500	•	•	•				Relé termico LR2-D1314/7-10A	Thermal relay LR2-D1314/7-10A	Disjoncteur LR2-D1314/7-10A	Therm. Relais LR2-D1314/7-10A	Relé termico LR2-D1314/7-10A
11	50 851000023				•	•	•	Scheda di potenza per EL6 inv. (mod. b)	Power card for EL6 inv. (mod.b)	Fiche puissance EL6 inv. (mod.b)	Leistungskarte EL6 inv. (Mod.b)	Ficha de poten. EL6 inv. (Mod.b)
11	50 851000025				•			Scheda di potenza per EL6 (mod. a)	Power card for EL6 (mod.a)	Fiche puissance EL6 (mod.a)	Leistungskarte EL6 (Mod.a)	Ficha de poten. EL6 (Mod.a)
12	42225000100	•	•	•				Disco con indice	Dial	Disque avec marçage	Indexscheibe	Disco con índice
13	422270012900				•	•		Inverter Mitsubishi 2,2kW	Inverter Mitsubishi 2,2kW	Inverter Mitsubishi 2,2kW	Inverter Mitsubishi 2,2kW	Inverter Mitsubishi 2,2kW
13	522270013000						•	Inverter Mitsubishi 4 kW 380V	Inverter Mitsubishi 4 kW 380V	Inverter Mitsubishi 4 kW 380V	Inverter Mitsubishi 4 kW 380V	Inverter Mitsubishi 4 kW 380V
14	50 851000029				•	•	•	Memory card	Memory card	Memory card	Memory card	Ficha de memoria
15	50 851000026				•	•	•	Programmatore EL6 per inverter	EL6 programmer for inverter	Programmeur EL6 pour inverseur	Programmschalter EL6 für Inverter	Programador EL6 para invertidor
15	50 851000028				•			Programmatore EL6	EL6 programmer	Programmeur EL6	Programmschalter EL6	Programador EL6
16	50 851000030				•	•	•	Sonda di temperatura	Temperature probe	Senseur température	Temperaturfühler	Sensor de temperatura
17	50 851000279	•	•	•	•	•	•	Trasformatore 0-400/230V 200VA	Transformer 0-400/230V 200VA	Transformateur 0-400/230V 200VA	Transformator 0-400/230V 200VA	Transformador 0-400/230V-200VA

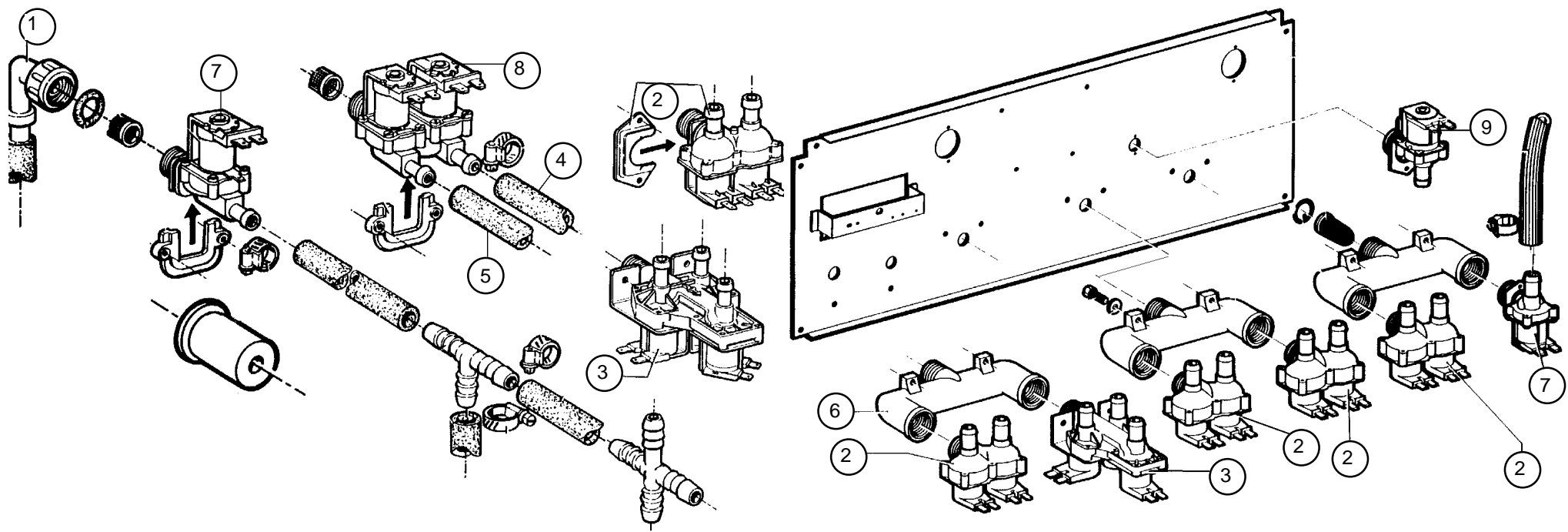

## F/8-11-18-23-26-33/16

Pos	Mod.	8	11	18	23	26	33	Descrizione	Description	Déscription	Beschreibung	Descripción
1	50 GI 801110	•	•					Raccordo per ingresso acqua 3/4"	Junction pipe for water supply 3/4"	Tuyau de raccordement d'eau 3/4"	Anschlußrohr für Wasserzulauf 3/4"	Conexión entrada de agua 3/4"
1	50 GI 801109			•	•	•	•	Raccordo per ingresso acqua 3/4"	Junction pipe for water supply 3/4"	Tuyau de raccordement d'eau 3/4"	Anschlußrohr für Wasserzulauf 3/4"	Conexión entrada de agua 3/4"
2	50 GI 851200	•	•	•				Valvola sol. d'ingr. 2 vie	2-way inlet solenoid valve	Vanne sol. entrée d'eau 2 voies	2-weg Einlaßmagnetventil	Válv. solen. entrada 2 vías
3	422090027700	•	•	•				Valvola sol. d'ingr. 3 vie	3-way inlet solenoid valve	Vanne sol. entrée d'eau 3 voies	3-weg Einlaßmagnetventil	Válv. solen. entrada 3 vías
4	50 GI 801116				•	•	•	Tubo elettrovalvola dispenser ø20	Dispenser solenoid valve tube ø20	Tuyau vanne solenoide dispenser ø20	Magnetventilrohr zum Dispenser ø20	Tubo válv. solen. dispenser ø20
5	50 GI 801113	•	•	•	•	•	•	Tubi elettrovalvola dispenser ø13	Dispenser solenoid valve tubes ø13	Tuyaux vanne solenoide dispenser ø13	Magnetventilrohre zum Dispenser ø13	Tubo válv. solen. dispenser ø13
6	422230005800				•			Raccordo a T	T-joint	Raccord à T	T-Verbindungsstück	Conexión en T
7	422090027600						•	Valvola sol. d'ingr. 1 via MÜLLER	1-way inlet solenoid valve MÜLLER	Vanne sol. entrée d'eau 1 voie MÜLLER	1-weg Einlaßmagnetventil MÜLLER	Válv. solen. entrada 1 via MÜLLER
8	422090031600				•	•	•	Valvola sol. d'ingr. 2 vie MÜLLER	2-way inlet solenoid valve MÜLLER	Vanne sol. entrée d'eau 2 voies MÜLLER	2-weg Einlaßmagnetventil MÜLLER	Válv. solen. entrada 2 vías MÜLLER
9	50 GI 851201	•	•					Valvola sol. d'ingr. 1 via	1-way inlet solenoid valve	Vanne sol. entrée d'eau 1 voie	1-weg Einlaßmagnetventil	Válv. solen. entrada 1 via

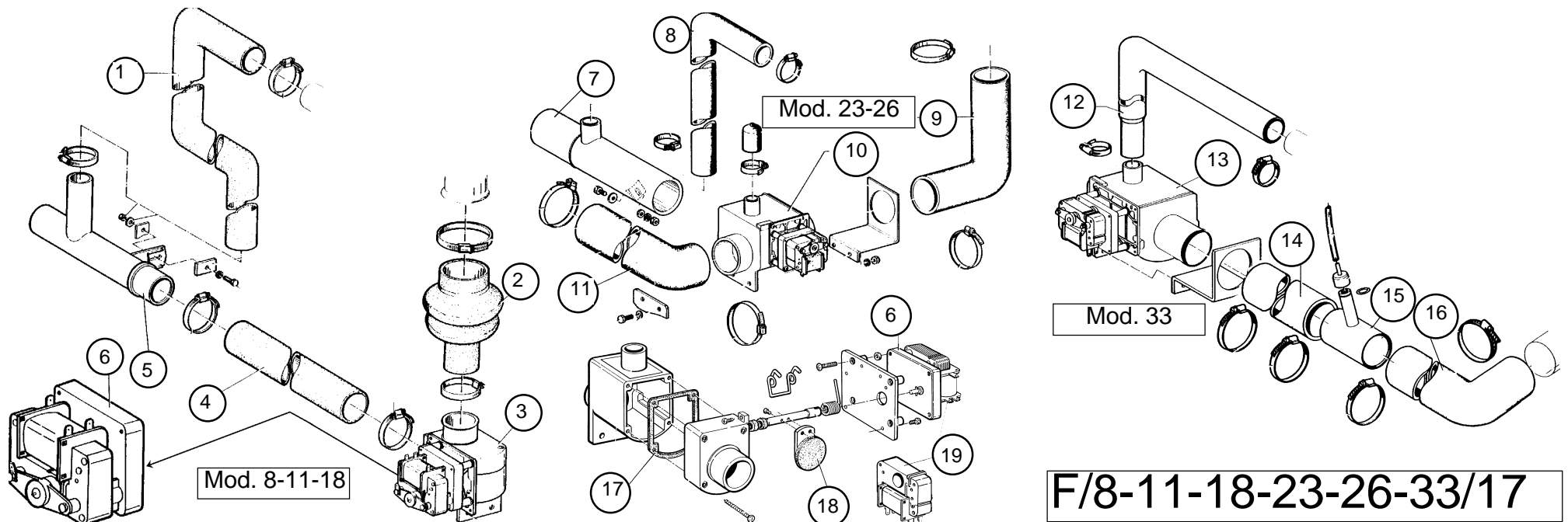

Pos	Mod.	8	11	18	23	26	33	Descrizione	Description	Déscription	Beschreibung	Descripción
1	422230008400	•	•					Troppo pieno	Overflow pipe	Tuyau de trop-plein	Überlaufrohr	Tubo de rebosamiento
1	422230020700		•					Troppo pieno	Overflow pipe	Tuyau de trop-plein	Überlaufrohr	Tubo de rebosamiento
2	422230012900	•	•	•				Tubo vasca EV di scarico	Tube for drain EV	Tuyau cuve EV de vidange	Auslaß EV für Bottichrohr	Tubo para EV de desagüe
3	422090025600	•	•	•				EV scar. MDP90 240V 50/60Hz NO	Drain EV MDP90 240V 50/60Hz	EV vid. MDP90 240V 50/60Hz	Ausl. EV MDP90 240V 50/60Hz NO	EV Desagüe MDP90 240V 50/60Hz NO
4	422230013700	•						Raccordo gomma EV tubo di scarico	Drain EV rubber hose	Raccord en gomme EV de vidange	Gummiverbindung für Auslaß EV	Conexión de goma, EV desagüe
4	422230013800		•					Raccordo gomma EV tubo di scarico	Drain EV rubber hose	Raccord en gomme EV de vidange	Gummiverbindung für Auslaß EV	Conexión de goma, EV desagüe
4	422230013900			•				Raccordo gomma EV tubo di scarico	Drain EV rubber hose	Raccord en gomme EV de vidange	Gummiverbindung für Auslaß EV	Conexión de goma, EV desagüe
5	422230010500	•	•	•				Tubo di scarico in PVC	PVC drain pipe	Tuyau d'évacuation en PVC	Abflußrohr in PVC	Tubo de desagüe de PVC
6	422090005111	•	•	•	•	•	•	Motorino EV di scarico	EV drain motor	Moteur EV de vidange	Motor für Auslaß EV	Motor para EV desagüe
7	422230010600			•	•			Tubo di scarico in PVC	PVC drain pipe	Tuyau d'évacuation en PVC	Abflußrohr in PVC	Tubo de desagüe de PVC
8	422230013100			•	•			Troppo pieno	Overflow pipe	Tuyau de trop-plein	Überlaufrohr	Tubo de rebosamiento
9	422230013300			•	•			Tubo vasca EV di scarico	Tube for drain EV	Tuyau cuve EV de vidange	Auslaß EV für Bottichrohr	Tubo para EV de desagüe
10	422090007500			•	•			EV scar. MDB300 240V 50/60Hz NO	Drain EV MDB300 240V 50/60Hz NO	EV vid. MDB300 240V 50/60Hz NO	Auslaß EV MDB300 240V 50/60Hz NO	EV desag. MDB300 240V 50/60Hz NO
11	422230013500			•	•			Raccordo gomma EV tubo di scarico	Drain EV rubber hose	Raccord en gomme EV de vidange	Gummiverbindung für Auslaß EV	Conexión de goma, EV desagüe
12	422230013000				•			Troppo pieno	Overflow pipe	Tuyau de trop-plein	Überlaufrohr	Tubo de rebosamiento
13	422090007500			•				EV scar. MDB300 240V 50/60Hz NO	Drain EV MDB300 240V 50/60Hz NO	EV vid. MDB300 240V 50/60Hz NO	Auslaß EV MDB300 240V 50/60Hz NO	EV desag. MDB300 240V 50/60Hz NO
14	422230014100			•				Raccordo gomma EV tubo di scarico	Drain EV rubber hose	Raccord en gomme EV de vidange	Gummiverbindung für Auslaß EV	Conexión de goma, EV desagüe
15	422230008300			•				Raccordo a T in PVC per pressostato	PVC T-joint for safety waterlevel switch	Raccord à T pour pressostat	T-Verbindung zum Wasserstandregler	Conexión en T para presostato
16	422130001400			•				Tubo di scarico	Drain pipe	Tuyau de vidange	Auslaßrohr	Tubo de desagüe
17	422090002502	•	•	•				Guarnizione EV scarico	Drain EV gasket	Joint EV de vidange	Dichtung des Auslaß EV	Junta EV desagüe
18	422090002516	•	•	•				Guarnizione tenuta EV scarico	Drain EV sealing gasket	Joint étanche EV de vidange	Dichtung des Auslaß EV	Junta de estanqueidad EV desagüe
19	422090005121	•	•	•	•	•	•	Avvolgimento motorino EV scarico	Drain EV motor coil	Bobine moteur EV de vidange	Spule des Auslaß EV motors	Bobinado motor EV desagüe

NO normalmente aperto, normally open, normalerweise offen, normalmete abierto EV= Elettrovalvola, electric valve, vanne électrique, elektrisches Ventil, válvula eléctrica

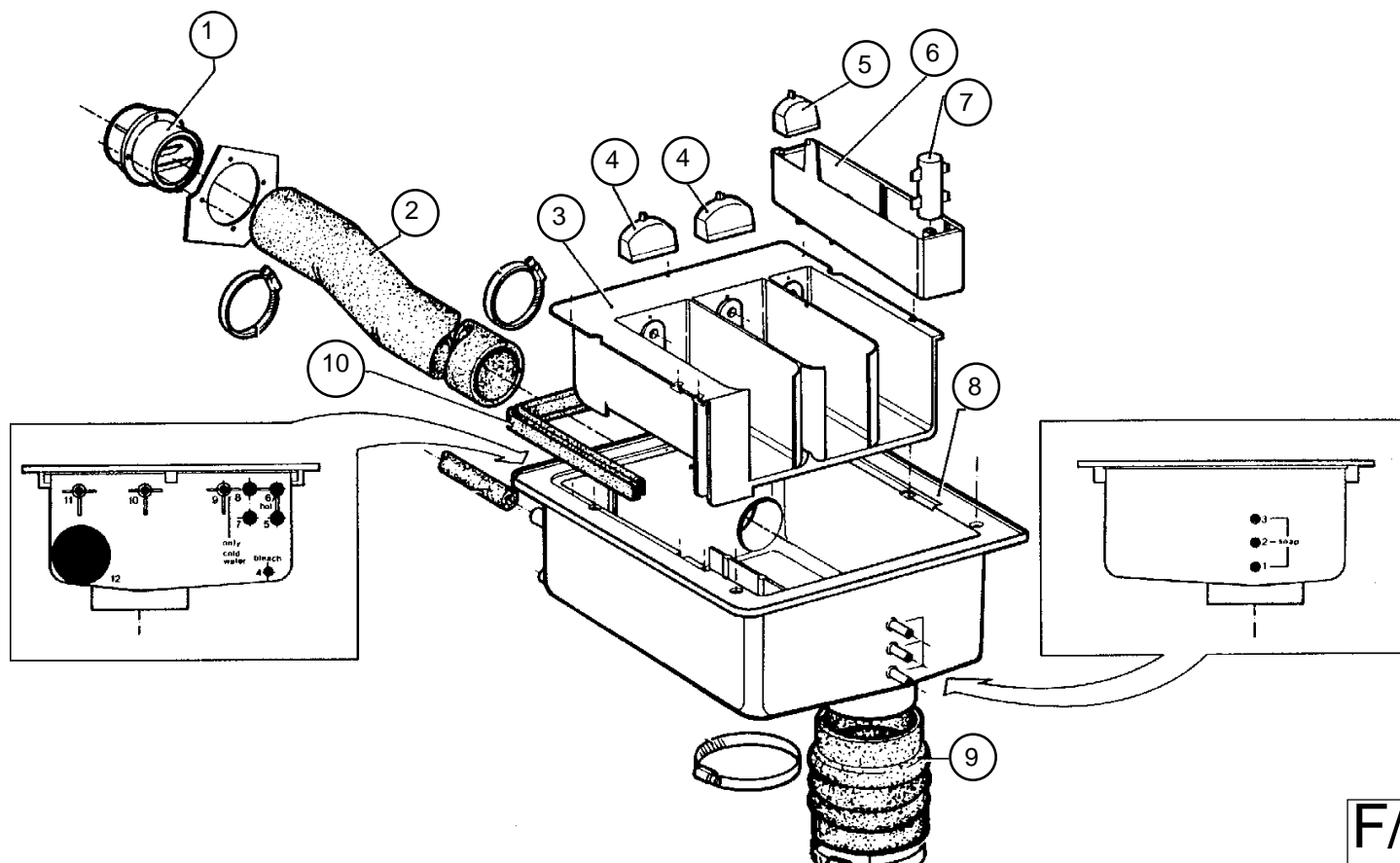

F/8-11-18-23-26-33/18

Pos	Mod.	8	11	18	23	26	33	Descrizione	Description	Déscription	Beschreibung	Descripción
1	422230010207	•	•	•	•	•	•	Griglia Air break system	Ventilating grille Air break system	Grille d'échappement air	Entlüftungsrost Air break system	Rejilla de ventilación
2	422230010703	•						Tubo Air break system	Ventilating hose Air break system	Tuyau d'échappement air	Entlüftungsrohr Air break system	Tubo de ventilación
2	422230010702		•					Tubo Air break system	Ventilating hose Air break system	Tuyau d'échappement air	Entlüftungsrohr Air break system	Tubo de ventilación
2	422230010700			•				Tubo Air break system	Ventilating hose Air break system	Tuyau d'échappement air	Entlüftungsrohr Air break system	Tubo de ventilación
2	422230010701				•	•		Tubo Air break system	Ventilating hose Air break system	Tuyau d'échappement air	Entlüftungsrohr Air break system	Tubo de ventilación
2	422230010704						•	Tubo Air break system	Ventilating hose Air break system	Tuyau d'échappement air	Entlüftungsrohr Air break system	Tubo de ventilación
3	422230010202	•	•	•	•	•	•	Vaschetta interna dispenser	Dispenser inner box	Bac interieur dispenser	Innenfach für Waschmittelbehälter	Recipiente interior
4	422230010206	•	•	•	•	•	•	Iniettore dispenser	Dispenser spray nozzle	Injecteur dispenser	Sprühdüse für Waschmittelbehälter	Inyector recipiente de jabón
5	422230010205	•	•	•	•	•	•	Iniettore dispenser (ammorbidente)	Spray nozzle for softener	Injecteur d'arrosage (aditif)	Sprühdüse für Einweichmittel	Inyector suavizante
6	422230010203	•	•	•	•	•	•	Vaschetta ammorbidente	Softener box PB3	Bac de rincage	Einweichmittelbehälter	Recipiente suavizante
7	422230010204	•	•	•	•	•	•	Sifone ammorbidente	U-trap for softener	Siphon aditif	Einweichmittelsiphon	Sifon suavizante
8	422230010201	•	•	•	•	•	•	Vasca dispenser esterna	Exterior dispenser box	Bac lessiviel extérieur	Äußerer Waschmittelbehälter	Recipiente exterior jabón
9	422230011500	•	•	•	•	•	•	Tubo dispenser vasca	Dispenser hose	Tuyau bac lessiviel, cuve	Rohr für Waschmittelbehälter	Tubo flexible recipiente de jabón
10	422230010900	•	•	•	•	•	•	Guarnizione dispenser	Dispenser gasket	Joint bac à lessive	Dichtung für Waschmittelbehälter	Junta recipiente jabón