

ISTRUZIONI PER L'INSTALLAZIONE E L'USO
INSTRUCTIONS FOR INSTALLATION AND USE
INSTRUCTIONS POUR L'INSTALLATION ET MODE D'EMPLOI
INSTALLATIONS- UND GEBRAUCHSANWEISUNG
INSTRUCCIONES PARA LA INSTALACIÓN Y PARA EL USO
INSTRUÇÕES PARA A INSTALAÇÃO E O USO

EM 10 - EM 15
EM 25 - EM 35
EM - 55

ESSICCATOIO ROTATIVO

GAS - ELETTRICO - VAPORE

TUMBLE-DRIER

GAS - ELECTRIC - STEAM

SÉCHOIR ROTATIF

GAZ - ÉLECTRIQUE- VAPEUR

WÄSCHETROCKNER

GAS, DAMPF, - BZW. ELEKTROBETRIEB

SECARROPAS ROTATIVO

GAS - ELECTRICO- VAPOR

MÁQUINA DE SECAR ROTATIVA

GÁS - ELÉCTRICA - VAPOR



grandimpianti[®]
Industrial Laundry Equipment

EM 10÷55.05

VIA MASIERE, 211/C
32037 - SOSPIROLO (BL)
ITALY

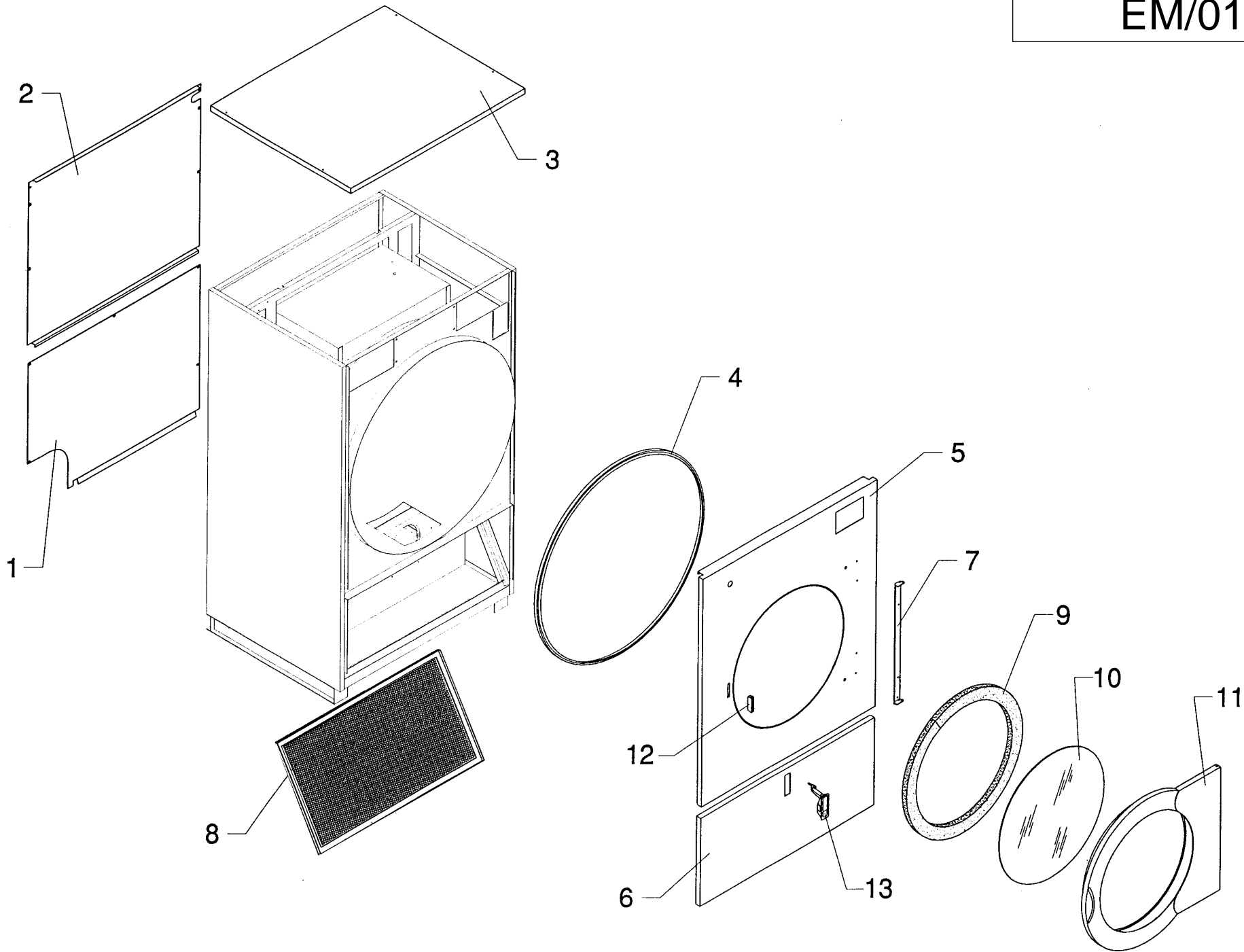

Pos.	Cod.	10	15	25	35	55	Descrizione	Description	Déscription	Beschreibung	Descripción
1	50 GI 901067	•					Pann. post. inf. mod. 10	Lower rear pannel mod. 10	Panneau post. inf. mod. 10	Untere Rückverkleidung Mod. 10	Panel post. inf. mod. 10
	50 GI 901077	•					Pann. post. inf. mod. 15	Lower rear pannel mod. 15	Panneau post. inf. mod. 15	Untere Rückverkleidung Mod. 15	Panel post. inf. mod. 15
	50 GI 901068		•	•			Pann. post. inf. mod. 25-35	Lower rear pannel mod. 25-35	Panneau post. inf. mod. 25-35	Untere Rückverkleidung Mod. 25-35	Panel post. inf. mod. 25-35
	50 GI 901069				•		Pann. post. inf. mod. 55	Lower rear pannel mod. 55	Panneau post. inf. mod. 55	Untere Rückverkleidung Mod. 55	Panel post. inf. mod. 55
2	50 GI 901070	•	•				Pann. post. super. elettrico	Upper rear panel elect. version	Panneau supér. arrière version élec.	Obere Rückverkleidung - elektr.	Panel superior trasero - ver. electr.
	50 GI 901071		•	•			Pann. post. super. elettrico	Upper rear panel elect. version	Panneau supér. arrière version élec.	Obere Rückverkleidung - elektr.	Panel superior trasero - ver. electr.
	50 GI 901072				•		Pann. post. super. elettrico	Upper rear panel elect. version	Panneau supér. arrière version élec.	Obere Rückverkleidung - elektr.	Panel superior trasero - ver. electr.
	50 GI 901073	•	•				Pann. post. super. gas	Upper rear panel gas version	Panneau supér. arrière version gaz	Obere Rückverkleidung - Gas	Panel superior trasero - ver. gas
	50 GI 901074		•	•			Pann. post. super. gas	Upper rear panel gas version	Panneau supér. arrière version gaz	Obere Rückverkleidung - Gas	Panel superior trasero - ver. gas
	50 GI 901075				•		Pann. post. super. gas	Upper rear panel gas version	Panneau supér. arrière version gaz	Obere Rückverkleidung - Gas	Panel superior trasero - ver. gas
	50 GI 901076	•	•				Pann. post. super. vapore	Upper rear panel steam version	Panneau supér. arrière version vapeur	Obere Rückverkleidung - Dampf	Panel superior trasero - ver. vapor
	50 GI 901078			•	•		Pann. post. super. vapore	Upper rear panel steam version	Panneau supér. arrière version vapeur	Obere Rückverkleidung - Dampf	Panel superior trasero - ver. vapor
	50 GI 901079				•		Pann. post. super. vapore	Upper rear panel steam version	Panneau supér. arrière version vapeur	Obere Rückverkleidung - Dampf	Panel superior trasero - ver. vapor
3	50 GI 901080	•					Coperchio superiore mod. 10	Top cover mod. 10	Couvercle supérieur mod. 10	Obere Abdeckung Mod. 10	Cubierta superior mod. 10
	50 GI 901081	•					Coperchio superiore mod. 15	Top cover mod. 15	Couvercle supérieur mod. 15	Obere Abdeckung Mod. 15	Cubierta superior mod. 15
	50 GI 901082		•				Coperchio superiore mod. 25	Top cover mod. 25	Couvercle supérieur mod. 25	Obere Abdeckung Mod. 25	Cubierta superior mod. 25
	50 GI 901083			•			Coperchio superiore mod. 35	Top cover mod. 35	Couvercle supérieur mod. 35	Obere Abdeckung Mod. 35	Cubierta superior mod. 35
	50 GI 901084				•		Coperchio superiore mod. 55	Top cover mod. 55	Couvercle supérieur mod. 55	Obere Abdeckung Mod. 55	Cubierta superior mod. 55
4	50 GI 901090	•	•				Guarnizione vasca mod. 10-15 250 cm	Basin gasket mod. 10-15 250 cm	Joint cuve mod. 10-15 250 cm	Wannendichtung Mod. 10-15 250 cm	Junta cuba mod. 10-15 250 cm
	50 GI 901091		•	•			Guarnizione vasca mod. 25-35 300 cm	Basin gasket mod.25-35 300 cm	Joint cuve mod. 25-35 300 cm	Wannendichtung Mod. 25-35 300 cm	Junta cuba mod. 25-35300
	50 GI 901092				•		Guarnizione vasca mod. 55 400 cm	Basin gasket mod. 55 400 cm	Joint cuve mod. 55 400 cm	Wannendichtung Mod. 55 400 cm	Junta cuba mod. 55 400 cm
5	50 GI 901085	•	•				Pann. front. sup. mod. 10-15	Upper front pannel mod. 10-15	Panneau frontal supér. mod. 10-15	Obere Frontverkleidung Mod. 10-15	Panel frontal sup. mod. 10-15
	50 GI 901086		•	•			Pann. front. sup. mod. 25-35	Upper front pannel mod. 25-35	Panneau frontal supér. mod. 25-35	Obere Frontverkleidung Mod. 25-35	Panel frontal sup. mod. 25-35
	50 GI 901087				•		Pann. front. sup. mod. 55	Upper front pannel mod. 55	Panneau frontal supér. mod. 55	Obere Frontverkleidung Mod. 55	Panel frontal sup. mod. 55
6	50 GI 901001	•					Sportello inf. mod. 10	Bottom lid mod. 10	Portillon infér. mod. 10	Untere Tür Mod. 10	Puerta inferior mod. 10
	50 GI 901002	•					Sportello inf. mod. 15	Bottom lid mod. 15	Portillon infér. mod. 15	Untere Tür Mod. 15	Puerta inferior mod. 15
	50 GI 901003		•	•			Sportello inf. mod. 25-35	Bottom lid mod. 25-35	Portillon infér. mod. 25-35	Untere Tür Mod. 25-35	Puerta inferior mod. 25-35
	50 GI 901004				•		Sportello inf. mod. 55	Bottom lid mod. 55	Portillon infér. mod. 55	Untere Tür Mod. 55	Puerta inferior mod. 55
7	50 GI 901043	•	•	•	•		Cerniera porta mod. 10-15-25-35	Door hinge mod. 10-15-25-35	Charnière portillon mod. 10-15-25-35	Türscharnier Mod. 10-15-25-35	Bisagra puerta mod. 10-15-25-35
	50 GI 901044				•		Cerniera porta mod. 55	Door hinge mod. 55	Charnière portillon mod. 55	Türscharnier Mod. 55	Bisagra puerta mod. 55
8	50 GI 901061	•					Filtro inox completo 810x435 mod. 10	S.steel Filter 810x435 mod. 10	Filtre inox complet 810x435 mod. 10	Inox Filter 810x435 Mod. 10	Filtro inox 810x435 mod. 1
	50 GI 901063		•				Filtro inox completo 670x810 mod. 15	S.steel Filter 670x810 mod. 15	Filtre inox complet 670x810 mod. 15	Inox Filter 670x810 Mod. 15	Filtro inox 670x810 mod. 15
	50 GI 901064			•			Filtro inox completo 740x1000 mod. 25	S.steel Filter 740x1000 mod. 25	Filtre inox complet 740x1000 mod. 25	Inox Filter 740x1000 Mod. 25	Filtro inox 740x1000 mod. 25
	50 GI 901065			•			Filtro inox completo 460x1000 mod. 35	S.steel Filter 460x1000 mod. 35	Filtre inox complet 460x1000 mod. 35	Inox Filter 460x1000 Mod. 35	Filtro inox 460x1000 mod. 35
	50 GI 901066				•		Filtro inox completo 840x700 mod. 55	S.steel Filter 840x700 mod. 55	Filtre inox complet 840x700 mod. 55	Inox Filter 840x700 Mod. 55	Filtro inox 840x700 mod. 55
9	50 GI 901038	•	•	•	•		Guarnizione spugna 2 mt.	Sponge gasket 2 mt.	Joint d'éponge 2 mt.	Schaumgummidichtung 2 m	Junta de esponja 2 mt.
	50 GI 901037				•		Guarnizione spugna 2 mt.	Sponge gasket 2 mt.	Joint d'éponge 2 mt.	Schaumgummidichtung 2 m	Junta de esponja 2 mt.
10	50 GI 901041	•	•	•	•		Vetro oblò diam. 497mm+H152	Door glass diam. 497mm+H152	Verre hublot diam. 497mm+H152	Türglas Durchm. 497mm+H152	Vidrio puerta diam. 497mm+H152
	50 GI 901043				•		Vetro oblò mod. 55	Door glass mod. 55	Verre hublot mod. 55	Türglas Mod. 55	Vidrio puerta mod. 55
11	50 GI 901045	•	•	•	•		Oblò completo mod. 10-15-25-35	Complete door mod. 10-15-25-35	Hublot complet mod. 10-15-25-35	Komplette Tür Mod. 10-15-25-35	Puerta completa mod. 10-15-25-35
	50 GI 901046				•		Oblò completo mod. 55	Complete door mod. 55	Hublot complet mod. 55	Komplette Tür Mod. 55	Puerta completa mod. 55
12	50 GI 901224	•	•	•	•	•	Calamita	Magnet	Aimant	Magnet	Imán
13	50 GI 901223	•	•	•	•	•	Maniglia sportello ispezione	Handle of Inspection lid	Poignée porte d'inspection	Griff Inspektionsklappe	Manija de la puerta de inspección

EM/02

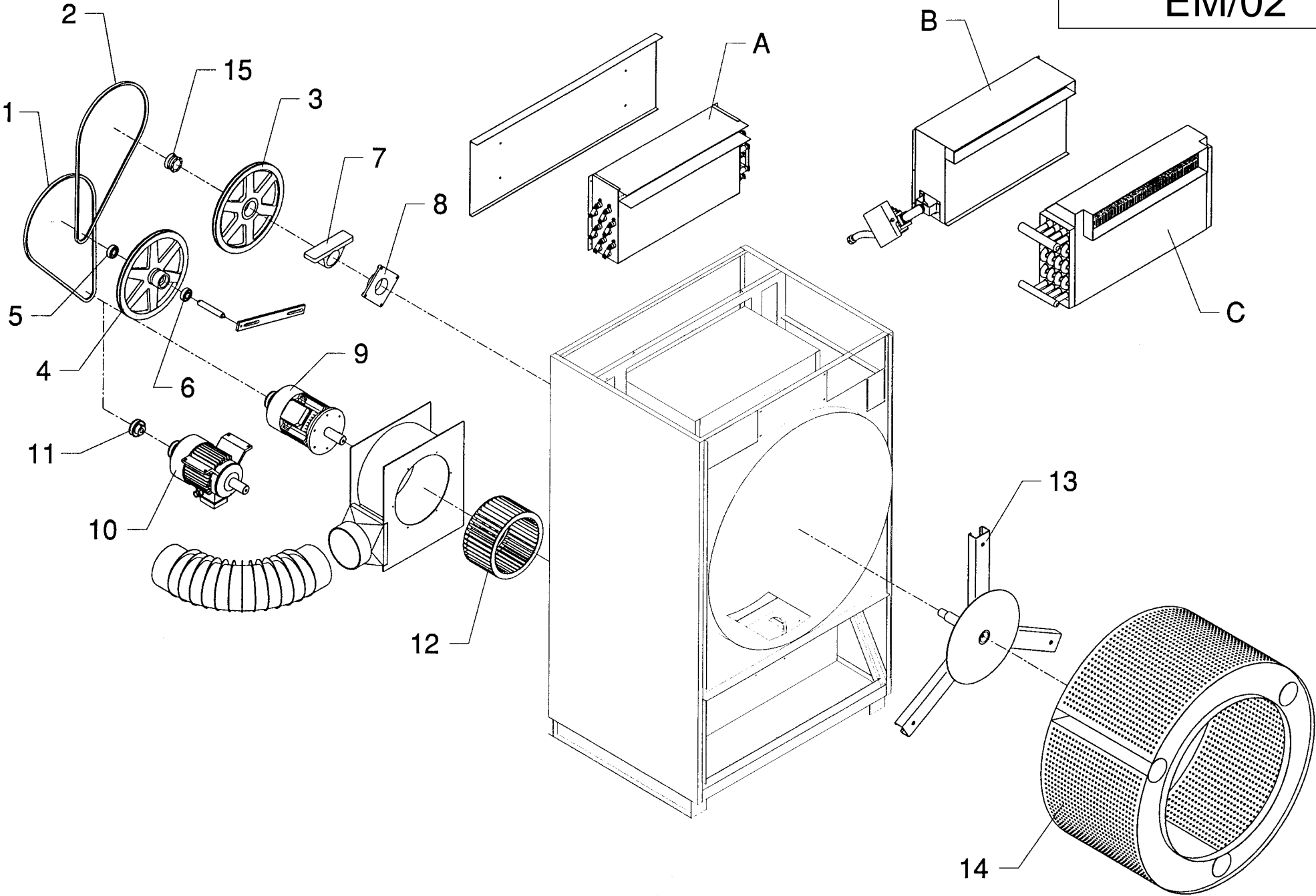

Pos.	Cod.	10	15	25	35	55	Descrizione	Description	Déscription	Beschreibung	Descripción
1	50 GI 901017	•					Cinghie SPZ 1287	Belts SPZ 128	Courroies SPZ 1287	Riemen SPZ 1287	Correas SPZ 1287
2	50 GI 901017	•					Cinghie SPZ 1287	Belts SPZ 1287	Courroies SPZ 1287	Riemen SPZ 1287	Correas SPZ 1287
1	50 GI 901027	•					Cinghie SPZ 1320	Belts SPZ 1320	Courroies SPZ 1320	Riemen SPZ 1320	Correas SPZ 1320
2	50 GI 901028	•					Cinghie SPZ 1362	Belts SPZ 1362	Courroies SPZ 1362	Riemen SPZ 1362	Correas SPZ 1362
1	50 GI 901028		•	•			Cinghie SPZ 1362 (NR 2 x EM 25-35)	Belts SPZ 1362 (NR 2 x EM 25-35)	Courroies SPZ 1362 (NR 2 x EM 25-35)	Riemen SPZ 1362 (NR 2 x EM 25-35)	Correas SPZ 1362 (NR 2x EM25-35)
2	50 GI 901029		•	•			Cinghie SPZ 1400 (NR 2 x EM 25-35)	Belts SPZ 1400 (NR 2 x EM 25-35)	Courroies SPZ 1400 (NR 2 x EM 25-35)	Riemen SPZ 1400 (NR 2 x EM 25-35)	Correas SPZ 1400 (NR 2x EM25-35)
	50 GI 901030					•	Cinghie SPA 1320 (NR 2 x EM 55)	Cinghie SPA 1320 (NR 2 x EM 55)	Courroies SPA 1320 (NR 2 x EM 55)	Riemen SPA 1320 (NR 2 x EM 55)	Correas SPA 1320 (NR 2 x EM55)
3	50 GI 901214	•	•				Puleggia cesto	Drum pulley	Poulie tambour	Riemenscheibe für Trommel	Polea tambor 50 Hz
	50 GI 901213		•	•			Puleggia cesto 50 Hz	Drum pulley 50 Hz	Poulie tambour 50 Hz	Riemenscheibe für Trommel 50 Hz	Polea tambor 50 Hz
	50 GI 902212		•	•			Puleggia cesto 60 Hz	Drum pulley 60 Hz	Pulie tambour 60 Hz	Riemenscheibe für Trommel 60 Hz	Polea tambor 60 Hz
	50 GI 901215					•	Puleggia cesto 50 Hz SPA355x3	Drum pulley 50 Hz SPA355x3	Poulie tambour 50 Hz SPA355x3	Riemensch. Trommel 50 Hz SPA355x3	Polea tambor 50 Hz SPA355x3
4	50 GI 901211	•	•				Puleggia rinvio 50 Hz	Driveback pulley 50 Hz	Poulie renvoi 50 Hz	Riemenscheibe 50 Hz	Polea de vuelta 50 Hz
	50 GI 902211	•	•				Puleggia rinvio 60 Hz	Driveback pulley 60 Hz	Poulie renvoi 60 Hz	Riemenscheibe 60 Hz	Polea de vuelta 60 Hz
	50 GI 901212		•	•			Puleggia rinvio	Driveback pulley	Poulie renvoi	Riemenscheibe	Polea de vuelta
5	50 GI 901116	•	•	•	•		Cuscinetto puleggia rinvio 6203 2RS	Driveback pulley bearing 6203 2RS	Palier poulie renvoi 6203 2RS	Kugellager für Riemensch.6203 2RS	Cojinete polea de vuelta 6203 2RS
6	50 GI 901116	•	•	•	•		Cuscinetto puleggia rinvio 6203 2RS	Driveback pulley bearing 6203 2RS	Palier poulie renvoi 6203 2RS	Kugellager für Riemensch.6203 2RS	Cojinete polea de vuelta 6203 2RS
7	50 GI 901110	•	•				Supp. cuscinetto ant. UCF 206	Fore bearing support UCF 206	Support roulement antér. UCF 206	Halter vorderes Kugellager UCF 206	Soporte cojinete delantero UCF 206
	50 GI 901112		•	•			Supp. cuscinetto ant. UCF 209	Fore bearing support UCF 209	Support roulement antér. UCF 209	Halter vorderes Kugellager UCF 209	Soporte cojinete delantero UCF 209
	50 GI 901114					•	Supp. cuscinetto ant. UCF	Fore bearing support UCF	Support roulement antér. UCF	Halter vorderes Kugellager UCF	Soporte cojinete delantero UCF
8	50 GI 901111	•	•				Supp. cuscinetto post. UCP 206	Rear bearing support UCF 206	Support roulement postér. UCF 206	Halter hinteres Kugellager UCF 206	Soporte cojinete trasero UCF 206
	50 GI 901113		•	•			Supp. cuscinetto post. UCP 207	Rear bearing support UCP 207	Support roulement postér. UCF 207	Halter hinteres Kugellager UCF 207	Soporte cojinete trasero UCF 207
	50 GI 901115					•	Supp. cuscinetto post. UCP	Rear bearing support UCP	Support roulement postér. UCF	Halter hinteres Kugellager UCF	Soporte cojinete trasero UCF
9	50 GI 951320	•	•				Motore cesto aspirazione	Extracting drum motor	Moteur tambour aspiration	Trommelsaugmotor	Motor tambor aspiración
	50 GI 951340			•	•		Motore aspirazione	Extracting drum	Moteur aspiration	Saugmotor	Motor aspiración
	50 GI 951350					•	Motore aspirazione	Extracting drum	Moteur aspiration	Saugmotor	Motor aspiración
10	50 GI 951330		•	•			Motore cesto	Drum motor	Moteur tambour	Trommelmotor	Motor tambor
	50 GI 951360					•	Motoriduttore cesto	Drum motor reduction gear	Motoréducteur tambour	Untersetzungsmotor Trommel	Motorreductor tambor
11	50 GI 901200	•					Puleggia motore 50 Hz	Motor pulley 50 Hz	Poulie moteur 50 Hz	Motorriemenscheibe 50 Hz	Polea motor 50 Hz
	50 GI 901201		•				Puleggia motore 50 Hz	Motor pulley 50 Hz	Poulie moteur 50 Hz	Motorriemenscheibe 50 Hz	Polea motor 50 Hz
	50 GI 901202			•	•		Puleggia motore	Motor pulley	Poulie moteur	Motorriemenscheibe	Polea motor
	50 GI 901203					•	Puleggia motore	Motor pulley	Poulie moteur	Motorriemenscheibe	Polea motor
12	50 GI 901204	•					Ventola aspirazione	Extraction fan	Ventilateur aspiration	Sauglüfter	Ventilador aspiración
	50 GI 901205		•				Ventola aspirazione	Extraction fan	Ventilateur aspiration	Sauglüfter	Ventilador aspiración
	50 GI 901207		•	•			Ventola aspirazione	Extraction fan	Ventilateur aspiration	Sauglüfter	Ventilador aspiración
	50 GI 901208					•	Ventola aspirazione (NR. 2xEM55)	Extraction fan (NR. 2xEM55)	Ventilateur aspiration (NR. 2xEM55)	Sauglüfter (NR. 2xEM55)	Ventilador aspiración (NR. 2xEM55)
13	50 GI 901161	•	•				Albero completo	Complete shaft	Arbre complet	Komplette Welle	Eje completo
	50 GI 901171		•	•			Albero completo	Complete shaft	Arbre complet	Komplette Welle	Eje completo
	50 GI 901172					•	Albero completo	Complete shaft	Arbre complet	Komplette Welle	Eje completo
14	50 GI 901150	•					Cesto senza albero	Drum without shaft	Tambour sans arbre	Trommel ohne Welle	Tambor sin eje
	50 GI 901160		•				Cesto senza albero	Drum without shaft	Tambour sans arbre	Trommel ohne Welle	Tambor sin eje
	50 GI 901170			•			Cesto senza albero	Drum without shaft	Tambour sans arbre	Trommel ohne Welle	Tambor sin eje
	50 GI 901179				•		Cesto senza albero	Drum without shaft	Tambour sans arbre	Trommel ohne Welle	Tambor sin eje
	50 GI 901189					•	Cesto senza albero	Drum without shaft	Tambour sans arbre	Trommel ohne Welle	Tambor sin eje
15	50 GI 901120	•	•	•	•		Calettatore	Spliner	Empatteur	Keilwellenverbindung	Acanalado
	50 GI 901121					•	Buss.conica pul. cesto BC2012 Foro 24	Drum pulley con.bush BC2012 ø 24	Anneau con. poulie tam.BC2012 Trou 24	Kon. Buchse Trommel BC2012 Loch 24	Casq.cón.polea tamb.BC2012 ø24
	50 GI 901122					•	Buss.conica pul. cesto BC3020 Foro 40	Drum pulley con.bush BC3020 ø 40	Anneau con. poulie tam.BC3020 Trou 40	Kon. Buchse Trommel BC3020 Loch 40	Casq.cón.polea tamb.BC3020 ø40

Pos.	Cod.	10	15	25	35	55	Descrizione	Description	Déscription	Beschreibung	Descripción
A	50 GI 901300	•					Cassetto elettrico completo	Complete electric box	Tiroir électrique complet	Kompletter Elektrokasten	Cajón eléctrico completo
	50 GI 901301		•				Cassetto elettrico completo	Complete electric box	Tiroir électrique complet	Kompletter Elektrokasten	Cajón eléctrico completo
	50 GI 901302			•	•		Cassetto elettrico completo	Complete electric box	Tiroir électrique complet	Kompletter Elektrokasten	Cajón eléctrico completo
	50 GI 901303					•	Cassetto elettrico completo	Complete electric box	Tiroir électrique complet	Kompletter Elektrokasten	Cajón eléctrico completo
	50 GI 901299						Cassetto elettrico completo 6KW	Complete electric box 6KW	Tiroir électrique complet 6KW	Kompletter Elektrokasten 6KW	Cajón eléctrico completo 6KW
	50 GI 901297						Cassetto elettrico completo 9KW	Complete electric box 9KW	Tiroir électrique complet 9KW	Kompletter Elektrokasten 9KW	Cajón eléctrico completo 9KW
	50 GI 901298						Cassetto elettrico completo 12KW	Complete electric box 12KW	Tiroir électrique complet 12KW	Kompletter Elektrokasten 12KW	Cajón eléctrico completo 12KW
B	50 GI 901175	•					Batteria gas completa	Complete gas battery	Batterie gaz complète	Kompletter Gas-Wärmetauscher	Bateria gas completa
	50 GI 901176		•				Batteria gas completa	Complete gas battery	Batterie gaz complète	Kompletter Gas-Wärmetauscher	Bateria gas completa
	50 GI 901177			•	•		Batteria gas completa	Complete gas battery	Batterie gaz complète	Kompletter Gas-Wärmetauscher	Bateria gas completa
	50 GI 901178					•	Batteria gas completa	Complete gas battery	Batterie gaz complète	Kompletter Gas-Wärmetauscher	Bateria vapor completa
C	50 GI 901180	•					Batteria vapore completa	Complete steam battery	Batterie vapeur complète	Kompletter Dampf- Wärmetauscher	Bateria vapor completa
	50 GI 901181		•				Batteria vapore completa	Complete steam battery	Batterie vapeur complète	Kompletter Dampf- Wärmetauscher	Bateria vapor completa
	50 GI 901182			•	•		Batteria vapore completa	Complete steam battery	Batterie vapeur complète	Kompletter Dampf- Wärmetauscher	Bateria vapor completa
	50 GI 901183					•	Batteria vapore completa	Complete steam battery	Batterie vapeur complète	Kompletter Dampf- Wärmetauscher	Bateria vapor completa

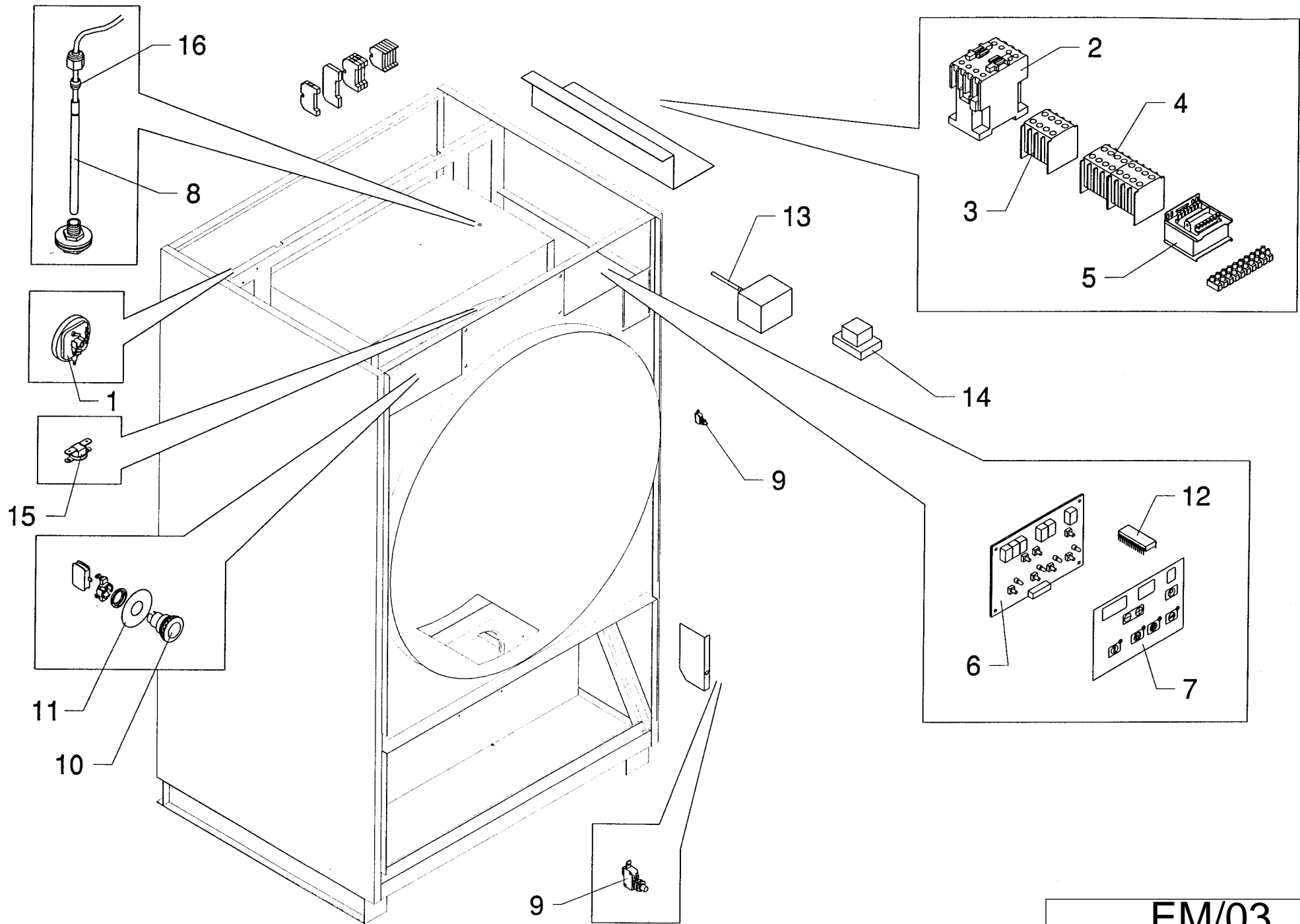

EM/03

Pos.	Cod.	10	15	25	35	55	Descrizione	Description	Déscription	Beschreibung	Descripción
1	50 GI 951022	•	•	•	•	•	Pressostato depressione	Pressure drop pressure switch	Pressostat dépression	Druckschalter Unterdruck	Presostato depresión
2	50 851000249	•					Contattore riscaldamento CLO2A301	Heating contactor CLO2A301	Contacteur chauffage CLO2A301	Kontaktgeber Heizung CLO2A301	Contactor calentamiento CLO2A301
	50 851000242	•					Contattore riscaldamento CLO2A300	Heating contactor CLO2A300	Contacteur chauffage CLO2A300	Kontaktgeber Heizung CLO2A300	Contactor calentamiento CLO2A300
	50 851000245			•	•		Contattore riscaldamento CLO2A310	Heating contactor CLO2A310	Contacteur chauffage CLO2A310	Kontaktgeber Heizung CLO2A310	Contactor calentamiento CLO2A310
	50 851000245					•	Contattore riscald.CLO2A310 Nr.2xEM55	Heat.contact.CLO2A310 Nr.2xEM55	Contact.chauff.CLO2A310 Nr.2xEM55	Kontaktg.Heizung CLO2A310 Nr.2xEM55	Cont. calent.CLO2A310 Nr.2xEM55
3	50 851000264	•	•				Contattore motore-aspirazione	Extracting motor contactor	Contacteur moteur aspiration	Kontaktgeber Saugmotor	Contactor motor-aspiración
	50 851000264			•	•	•	Contattore aspirazione	Extraction contactor	Contacteur aspiration	Kontaktgeber Sauglüfter	Contactor aspiración
4	50 851000262			•	•	•	Contattore motor (nr.2x25-35)	Motor contactor (nr.2x25-35)	Contacteur moteur (nr.2x25-35)	Kontaktgeber Motor(Nr.2x25-35)	Contactor motor (nr.2x25-35)
5	50 GI 951275	•	•	•	•	•	Trasformatore 220V/12V	Transformer 220V/12V	Transformateur 220V/12V	Transformator	Transformador 220V/12V
6	50 GI 951028	•	•	•	•	•	Microprocessore	Microprocessor	Microprocesseur	Mikroprozessor	Microprocesor
7	50 GI 951029	•	•	•	•	•	Tastiera per microprocessore	Microprocessor keypad	Clavier microprocesseur	Tastenfeld Mikroprozessor	Teclado microprocesor
8	50 GI 951033	•	•	•	•	•	Sonda temperatura PT100	Temperature probePT100	Sonde température PT100	Temperaturfühler PT100	Sonda temperatura PT100
9	50 GI 951020	•	•	•	•	•	Sensore porta ispezione	Inspection door sensor	Senseur porte inspection	Sensor Inspektionsklappe	Sensor puerta inspección
10	540751000025	•	•	•	•	•	Pulsante emergenza	Emergency push-button	Bouton d'urgence	Nottaste	Botón de emergencia
11	540751000026	•	•	•	•	•	Targa "Emergency stop"	"Emergency stop" plate	Plaquette "Emergency stop"	Schild "Emergency stop"	Placa "Emergency stop"
12	50 GI 951032	•	•	•	•	•	Eprom per LSD	LSD Eprom	Eprom LSD	Eprom LSD	Eprom para LSD
13	50 GI 951027	•	•	•	•	•	Sonda umidità relativa	Relative Humidity probe	Sonde humidité relative	Fühler relative Feuchtigkeit	Sonda humedad relativa
14	50 GI 951026	•	•	•	•	•	Alimentatore per sonda	Power supply for probe	Alimentation sonde	Fühlerstromversorgung	Alimentador para sonda
15	50 GI 951010	•	•	•	•	•	Termostato di sicurezza	Safety thermostat	Thermostat de sécurité	Sicherheitsthermostat	Termostato de seguridad
16	50 GI 951034	•	•	•	•	•	Porta sonda	Probe holder	Support sonde	Fühlerhalter	Soporte sonda

**BATTERIA ELETTRICA
ELECTRIC HEATERS
EME 10/15**

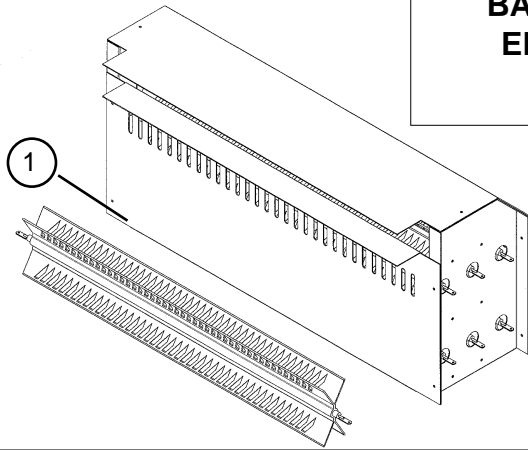

**BATTERIA ELETTRICA
ELECTRIC HEATERS
EME 25/35/55**

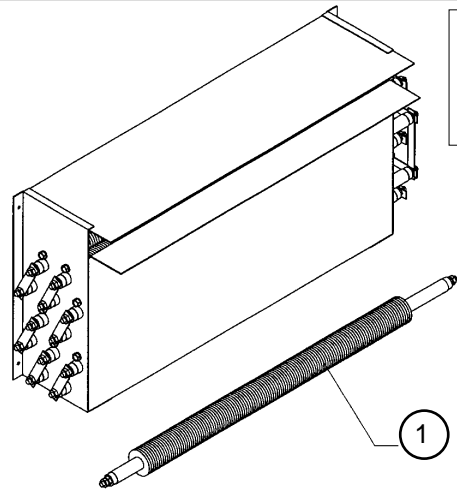

**BATTERIA VAPORE
STEAM HEATER**

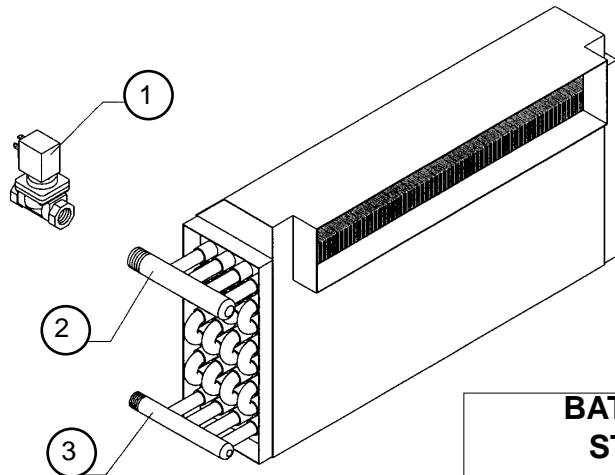

EM/04

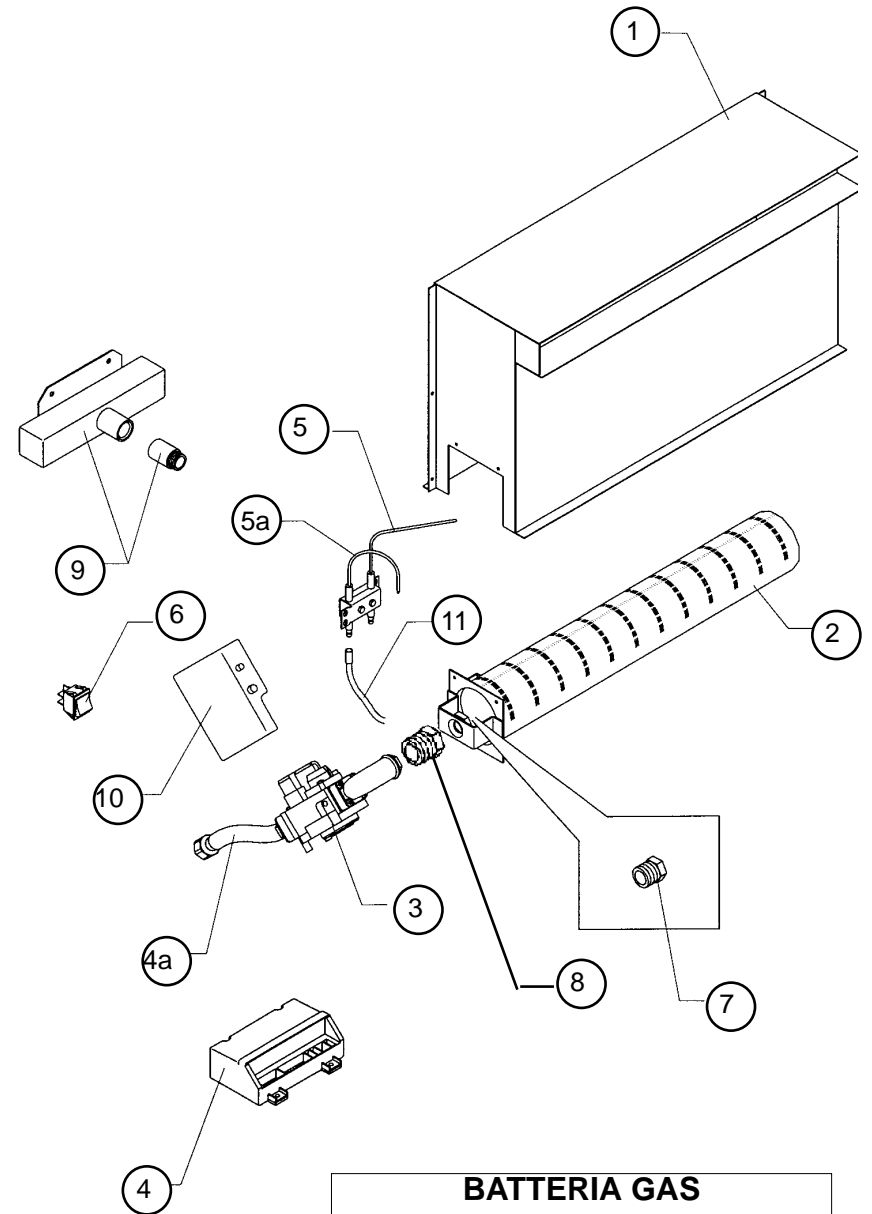

**BATTERIA GAS
HAS HEATER**

Cod.	10	15	25	35	55	Descrizione	Description	Déscription	Beschreibung	Descripción
						BATTERIA ELETTRICA	ELECTRIC BATTERY	BATTERIE ÉLECTRIQUE	ELEKTROWÄRMETAUSCHER	BATERIA ELÉCTRICA
1	50 GI 951042	•				Resistenza all.230V 1600W 50-60Hz	Fin.al. heat.el.230V 1600W 50-60Hz	Résist.al. 230V 1600W 50-60Hz	Alum. Heizwider. 230V 1600W 50-60Hz	Res. alum.230V 1600W 50-60Hz
	50 GI 951041		•			Resistenza all.220V 2000W 50-60Hz	Fin.al. heat.el.220V 2000W 50-60Hz	Résist.al. 220V 2000W 50-60Hz	Alum. Heizwider. 220V 2000W 50-60Hz	Res. alum.220V 2000W 50-60Hz
	50 GI 951031			•	•	Resistenza 110V 1200W 50-60Hz	Heating el.110V 1200W 50-60Hz	Résistance 110V 1200W 50-60Hz	Heizwiderstand 110V 1200W 50-60Hz	Resistencia 110V 1200W 50-60Hz
	50 GI 952031				•	Resistenza 130V 1200W 50-60Hz(440V)	Heat.el.130V 1200W 50-60Hz(440V)	Résist. 130V 1200W 50-60Hz(440V)	Heizwider. 130V 1200W 50-60Hz(440V)	Res.130V 1200W 50-60Hz(440V)
						BATTERIA GAS	GAS BATTERY	BATTERIE GAZ	GASWÄRMETAUSCHER	BATERIA GAS
1	50 GI 901174	•	•			Corpo cassetto bruc. gas	Gas burn. drawer	Corp tiroir brûleur gas	Brennergehäuse	Cuerpo cajón quemador gas
	50 GI 951186			•	•	Corpo cassetto bruc. gas	Gas burn. drawer	Corp tiroir brûleur gas	Brennergehäuse	Cuerpo cajón quemador gas
	50 GI 951187				•	Corpo cassetto bruc. gas	Gas burn. drawer	Corp tiroir brûleur gas	Brennergehäuse	Cuerpo cajón quemador gas
2	50 GI 901190	•	•		•	Bruciatore (nr.4 per EM55)	Burner (nr.4 per EM55)	Brûleur (nr.4 per EM55)	Brenner (Nr. 4 für EM55)	Quegador (nr.4 per EM55)
	50 GI 901191				•	Bruciatore	Burner	Brûleur	Brenner	Quegador
3	50 GI 901512	•	•	•	•	Elettrovalvola gas	Gas solenoid valve	Solenoide gaz	Gasmagnetventil	Solenoide gas
	50 GI 901513				•	Elettrovalvola gas	Gas solenoid valve	Solenoide gaz	Gasmagnetventil	Solenoide gas
4	50 GI 951508	•	•	•	•	Basetta elettronica Honeywell	Honeywell electronic board	Carte électronique Honeywell	Elektronische Karte Honeywell	Placa electrónica Honeywell
	50 GI 901507				•	Basetta elettronica Honeywell	Honeywell electronic board	Carte électronique Honeywell	Elektronische Karte Honeywell	Placa electrónica Honeywell
5	50 GI 951516	•	•	•	•	Elettrodi accensione	Ignition electrode	Électrode d'allumage	Zündelektrode	Electrodo de encendido
	50 GI 951517	•	•	•	•	Elettrodi accensione "Kantal"	Ignition electrode "Kantal"	Électrode d'allumage "Kantal"	Zündelektrode "Kantal"	Electrodo de encendido "Kantal"
6	50 GI 851145	•	•	•	•	Deviatore verde reset gas	Green deviator for gas reset	Déviateur vert reset gaz	Grüner Schalter für Wiedereinschaltung	Desviador verde reposición gas
7	50 GI 9011981	•			•	Ugello gas ø1,95 Bruc. Polidoro G30-31	Gas nozzle ø1,95 Polid.Burn.G30-31	Inj. gaz ø1,95 Brül. Polidoro G30-31	Gasdüse ø1,95 Bruc. Polidoro G30-31	Boquilla gas ø1,95 Bruc. Polid. G30-31
	50 GI 9011982		•			Ugello gas ø2,30 Bruc. Polidoro G30-31	Gas nozzle ø2,30 Polid.Burn.G30-31	Inj. gaz ø2,30 Brül. Polidoro G30-31	Gasdüse ø2,30 Bruc. Polidoro G30-31	Boquilla gas ø2,30 Bruc. Polid. G30-31
	50 GI 9011983		•	•		Ugello gas ø2,75 Bruc. Polidoro G30-31	Gas nozzle ø2,75 Polid.Burn.G30-31	Inj. gaz ø2,75 Brül. Polidoro G30-31	Gasdüse ø2,75 Bruc. Polidoro G30-31	Boquilla gas ø2,75 Bruc. Polid. G30-31
	50 GI 9011984	•			•	Ugello gas ø3,50 Bruc. Polidoro G20	Gas nozzle ø3,50 Polid.Burn.G20	Inj. gaz ø3,50 Brül. Polidoro G20	Gasdüse ø3,50 Bruc. Polidoro G20	Boquilla gas ø3,50 Bruc. Polid. G20
	50 GI 9011985		•			Ugello gas ø4,20 Bruc. Polidoro G20	Gas nozzle ø4,20 Polid.Burn.G20	Inj. gaz ø4,20 Brül. Polidoro G20	Gasdüse ø4,20 Bruc. Polidoro G20	Boquilla gas ø4,20 Bruc. Polid. G20
	50 GI 9011986		•	•		Ugello gas ø4,80 Bruc. Polidoro G20	Gas nozzle ø4,80 Polid.Burn.G20	Inj. gaz ø4,80 Brül. Polidoro G20	Gasdüse ø4,80 Bruc. Polidoro G20	Boquilla gas ø4,80 Bruc. Polid. G20
8	50 GI 901197	•	•	•	•	Portaugelli bruciatori Polidoro	Polidoro nozzle holder	Porte injecteur Polidoro	Polidoro Düsehalter	Porta boquilla Polidoro
9	50 GI 901196	•	•			Collettore gas	Gas manifold	Collecteur gaz	Gaskollektor	Colector gas
	50 GI 901195			•	•	Collettore gas	Gas manifold	Collecteur gaz	Gaskollektor	Colector gas
10	50 GI 953010	•	•	•	•	Tubo alimentazione gas acciaio	Gas steel feed pipe	Tuyau aliment. gas en acier	Gasrohr aus Stahl	Tubo alimentación gas en acero
11	50 GI 951515	•	•	•	•	Cavo alta tensione	High voltage cable	Câble haute tension	Hochspannungskabel	Cable alta tensión
						BATTERIA VAPORE	STEAM BATTERY	BATTERIE VAPEUR	DAMPF-WÄRMETAUSCHER	BATERIA VAPOR
1	50 GI 951219	•	•			Elettrovalvola vapore 3/4"Danfoss	Danfoss steam solenoid valve 3/4"	Solenoide vapeur Danfoss 3/4"	Dampfmagnetventil Danfoss 3/4"	Solenoide vapor Danfoss 3/4"
	50 GI 951220			•	•	Elettrovalvola vapore 1"Danfoss	Danfoss steam solenoid valve 1"	Solenoide vapeur Danfoss 1"	Dampfmagnetventil Danfoss 1"	Solenoide vapor Danfoss 1"
	50 GI 951222				•	Elettrovalvola vapore 1 1/2"Danfoss	Danfoss steam solenoid valve 1 1/2"	Solenoide vapeur Danfoss 1 1/2"	Dampfmagnetventil Danfoss 1 1/2"	Solenoide vapor Danfoss 1 1/2"
	50 GI 951221				•	Elettrovalvola vapore Pneumatica 1"	Danfoss pneum.steam solen.valve 1"	Solenoide vapeur pneum. Danfoss 1"	Pneumat. Dampfmagnetventil Danfoss 1"	Solen.vapor pneum.Danfoss 1"
2		•	•			Entrata vapore diam 3/4"	Steam inlet diam. 3/4"	Entrée vapeur diam. 3/4"	Dampfeingang Ø 3/4"	Entrada vapor diám. 3/4"
				•	•	Entrata vapore diam 1"	Steam inlet diam. 1"	Entrée vapeur diam. 1"	Dampfeingang Ø 1"	Entrada vapor diám. 1"
					•	Entrata vapore diam 1 1/2"	Steam inlet diam. 1 1/2"	Entrée vapeur diam. 1 1/2"	Dampfeingang Ø 1 1/2"	Entrada vapor diám. 1 1/2"
3		•	•			Uscita condensa diam. 1/2"	Condensate outlet diam. 1/2"	Sortie condensation diam. 1/2"	Kondenswasserausgang Ø 1/2"	Salida condens. diám. 1/2"
				•	•	Uscita condensa diam. 3/4"	Condensate outlet diam. 3/4"	Sortie condensation diam. 3/4"	Kondenswasserausgang Ø 3/4"	Salida condens. diám. 3/4"
					•	Uscita condensa diam. 1"	Condensate outlet diam. 1"	Sortie condensation diam. 1"	Kondenswasserausgang Ø 1"	Salida condens. diám. 1"