

SKT60G2

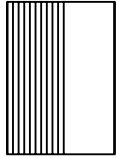

SKT60GLR

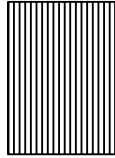

SKT60GR2

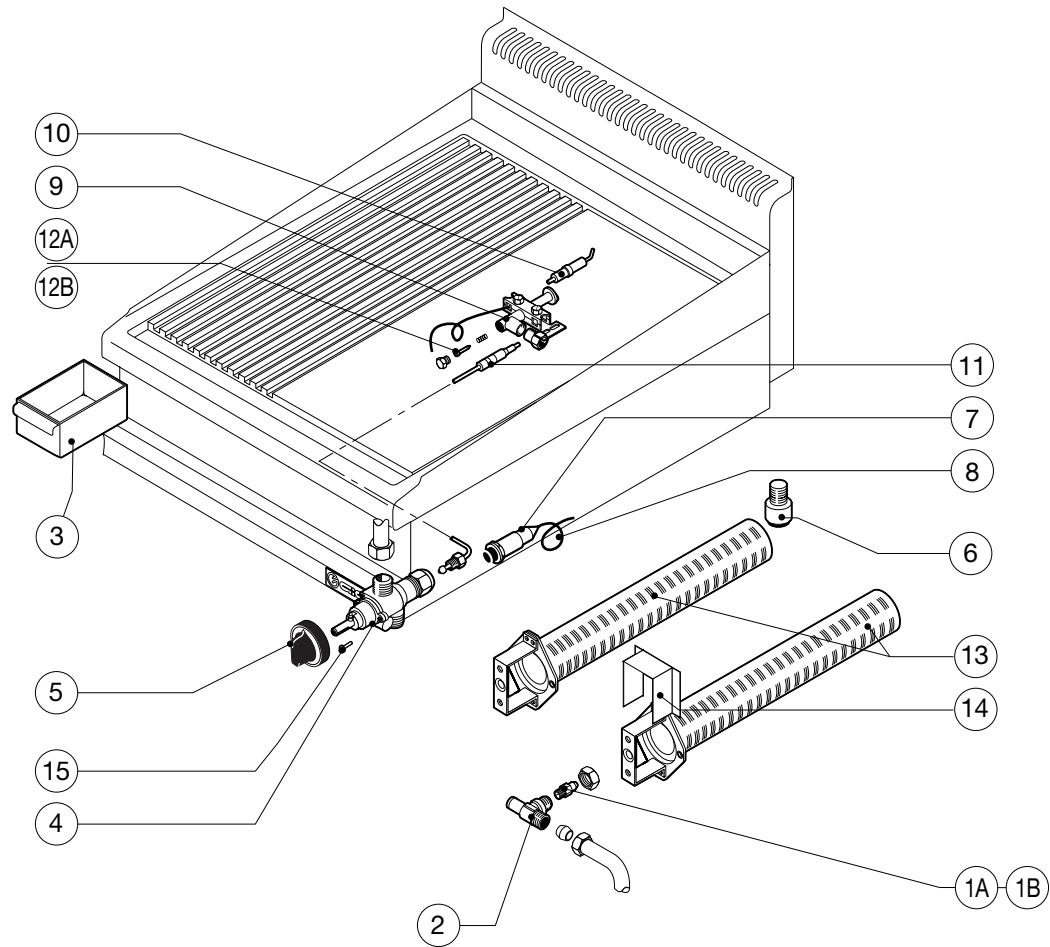

A = GPL / LP gas / Gaz liquide / Flüssiggas
 B = Gas metano / Natural gas / Gaz naturel / Erdgas

