



N plano C-1145	Firma 	Fecha 4-2002	Aparato ARMAZON Y MUEBLE LAVADORAS LF-7, 10, 14	Lamina 1	Fogor Industrial S.Coop. <b>FAOOR</b>  Orate
-------------------	--	-----------------	---	-------------	--

MOD.

LAVADORAS ALTAS REVOLUCIONES

ZONA

ARMAZON Y MUEBLE

PLANO

C-1145

ITEM	CODIGO	DENOMINACION	TEXTO	LF-7	LF-10	LF-14		NOTAS
1	P510312	Portamandos program. mecanico		1	1	-		
1	P520326	Portamandos program. mecanico		-	-	1		
1	P510313	Portamandos program. electronico		1	1	-		
1	P520327	Portamandos program. electronico		-	-	1		
2	P500310	Embellecedor portama. mecanico		1	1	1		
2	P500323	Embellecedor portama. ( MP )		1	1	1		
2	P500325	Embellecedor portama. ( MPP )		1	1	1		
3	P506510	Adhesivo modelo LF/E-7		1	-	-		
3	P506511	Adhesivo modelo LF/AC-7		1	-	-		
3	P506512	Adhesivo modelo LF/V-7		1	-	-		
3	P506513	Adhesivo modelo LF/E-7 A		1	-	-		
3	P506514	Adhesivo modelo LF/AC-7 A		1	-	-		
3	P506515	Adhesivo modelo LF/E-7 MP		1	-	-		
3	P506516	Adhesivo modelo LF/AC-7 MP		1	-	-		
3	P506517	Adhesivo modelo LF/V-7 MP		1	-	-		
3	P506518	Adhesivo modelo LF/E-7 MPP		1	-	-		
3	P506519	Adhesivo modelo LF/AC-7 MPP		1	-	-		
3	P506520	Adhesivo modelo LF/V-7 MPP		1	-	-		
3	P516504	Adhesivo modelo LF/E-10		-	1	-		
3	P516505	Adhesivo modelo LF/AC-10		-	1	-		
3	P516506	Adhesivo modelo LF/V-10		-	1	-		
3	P516507	Adhesivo modelo LF/E-10 A		-	1	-		
3	P516508	Adhesivo modelo LF/AC-10 A		-	1	-		
3	P516509	Adhesivo modelo LF/E-10 MP		-	1	-		
3	P516510	Adhesivo modelo LF/AC-10 MP		-	1	-		
3	P516511	Adhesivo modelo LF/V-10 MP		-	1	-		
3	P516512	Adhesivo modelo LF/E-10 MPP		-	1	-		
3	P516513	Adhesivo modelo LF/AC-10 MPP		-	1	-		
3	P516514	Adhesivo modelo LF/V-10 MPP		-	1	-		

MOD.

LAVADORAS ALTAS REVOLUCIONES

ZONA

ARMAZON Y MUEBLE

PLANO

C-1145

ITEM	CODIGO	DENOMINACION	TEXTO	LF-7	LF-10	LF-14		NOTAS
3	P526505	Adhesivo modelo LF/E-14		-	-	1		
3	P526506	Adhesivo modelo LF/AC-14		-	-	1		
3	P526507	Adhesivo modelo LF/V-14		-	-	1		
3	P526508	Adhesivo modelo LF/E-14 A		-	-	1		
3	P526509	Adhesivo modelo LF/AC-14 A		-	-	1		
3	P526510	Adhesivo modelo LF/E-14 MP		-	-	1		
3	P526511	Adhesivo modelo LF/AC-14 MP		-	-	1		
3	P526512	Adhesivo modelo LF/V-14 MP		-	-	1		
3	P526513	Adhesivo modelo LF/E-14 MPP		-	-	1		
3	P526514	Adhesivo modelo LF/AC-14 MPP		-	-	1		
3	P526515	Adhesivo modelo LF/V-14 MPP		-	-	1		
4	P510306	Panel frontal		1	1	-		
4	P520322	Panel frontal		-	-	1		
5	P510325	Cortina		1	1	1		
6	P510311	Suplemento panel frontal inferior		1	1	-		
6	P520325	Suplemento panel frontal inferior		-	-	1		
7	Q151323	Tornillo broca Ø4,8x16		2	2	2		
8	P500111	Armazon completo LF-7		1	-	-		
8	P510103	Armazon completo LF-10		-	1	-		
8	P520123	Armazon completo LF-14		-	-	1		
9	Q151323	Tornillo broca Ø4,8x16		6	6	6		
10	P500335	Panel lateral LF-7		2	-	-		
10	P510316	Panel lateral LF-10		-	2	-		
10	P520338	Panel lateral LF-14		-	-	2		
11	X010503	Muelle enganche piton		2	2	2		
12	Q419007	Remache tubular Ø3,2x6		4	4	4		
13	P450303	Piton de enganche		2	2	2		
14	Q232030	Arandela plana A-5		2	2	2		
15	Q221308	Tuerca exagonal autoseguro M-5		2	2	2		

MOD.

LAVADORAS ALTAS REVOLUCIONES

ZONA

ARMAZON Y MUEBLE



PLANO

C-1145

ITEM	CODIGO	DENOMINACION	TEXTO	LF-7	LF-10	LF-14	NOTAS
16	Q221342	Remache exagonal M-5		8	8	8	
17	Q302022	Arandela plana Ø16xØ6x1,2		8	8	8	
18	Q242030	Arandela abanico A-5		8	8	8	
19	Q012031	Tornillo exagonal M-5x10		8	8	8	
20	Q151323	Tornillo broca Ø4,8x16		3	3	3	
21	Q221342	Remache exagonal M-5		13	13	13	
22	Q302022	Arandela plana Ø16xØ6x1,2		13	13	13	
23	Q242030	Arandela abanico A-5		13	13	13	
24	Q012031	Tornillo exagonal M-5x10		13	13	13	
25	P510322	Sujecion panel posterior LF-7 y 10		1	1	-	
25	P520335	Sujecion panel posterior LF-14		-	-	1	
	Q221342	Remache exagonal M-5		4	4	4	
	Q302022	Arandela plana Ø16xØ6x1,2		4	4	4	
	Q242030	Arandela abanico A-5		4	4	4	
	Q012031	Tornillo exagonal M-5x10		4	4	4	
26	Q162030	Tuerca exagonal M-5		3	3	3	
27	Q232030	Arandela plana A-5		3	3	3	
28	3714500	Perfil esponj. adhesivo 20x2x3000		1	1	1	
29	P510307	Panel posterior LF-7 y 10		1	1	-	
29	P520331	Panel posterior LF-14		-	-	1	
30	Q042022	Tornillo avellanado M-4x15		2	2	2	
31	P440704	Tapa cubeta		1	1	1	
32	P440705	Soporte tapa cubeta		1	1	1	
33	Q012031	Tornillo exagonal M-5x10		2	2	2	
34	Q242030	Arandela abanico A-5		2	2	2	
35	Q302022	Arandela plana Ø16xØ6x1,2		2	2	2	
36	Q221342	Remache exagonal M-5		2	2	2	
37	P500338	Encimera LF-7		1	-	-	
37	P510309	Encimera LF-10		-	1	-	
37	P520339	Encimera LF-14		-	-	1	

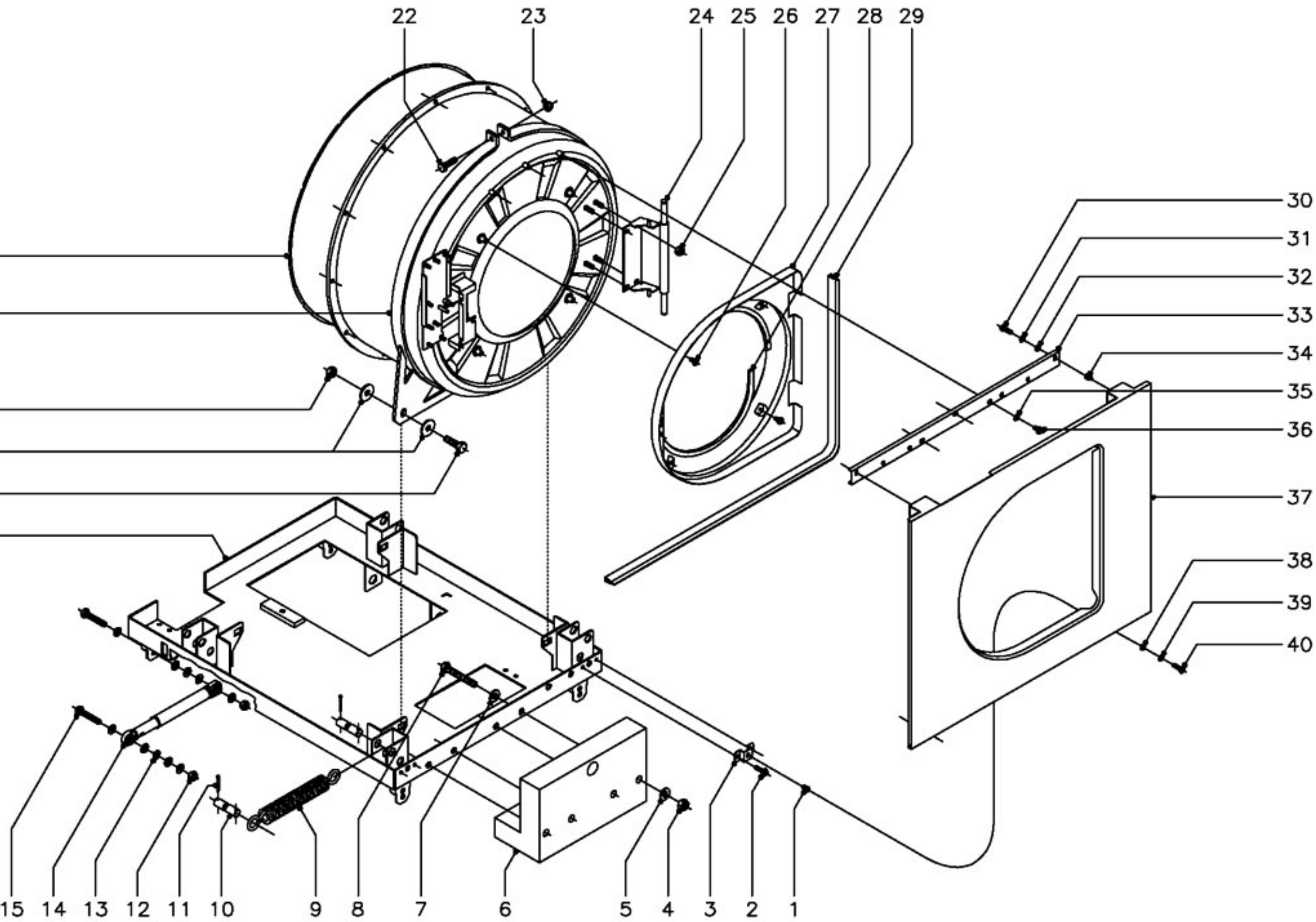



N.º plano: C-1146  
 Firma:   
 Fecha: 4-2002  
 Aparato: LAVADORAS LF-7, 10, 14  
 AMORTIGUACION Y FREINTE  
 Laminas: 2  
 Fabricante: Fagor Industrial S. Coop. **FAGOR** 

MOD.

LAVADORAS ALTAS REVOLUCIONES

ZONA

AMORTIGUACION Y FRENTE

PLANO

C-1146

ITEM	CODIGO	DENOMINACION	TEXTO	LF-7	LF-10	LF-14			NOTAS
1	Q221342	Remache exagonal M-5		2	2	2			
2	Q151323	Tornillo broca Ø4,8x16		4	4	-			
3	P510323	Soporte frontal inferior		2	2	-			
4	Q221307	Tuerca exagonal autoseguro M-12		4	4	5			
5	Q301010	Arandela plana Ø27xØ12,5x2,5		4	4	5			
6	P506111	Contrapeso		1	-	-			
6	P516111	Contrapeso		-	1	-			
6	P526117	Contrapeso		-	-	1			
7	Q301010	Arandela plana Ø27xØ12,5x2,5		4	4	5			
8	Q151357	Tornillo exagonal M-12x80		4	4	-			
8	Q011379	Tornillo exagonal M-12x70		-	-	3			
8	Q151355	Tornillo exagonal M-12x110		-	-	2			
9	P500201	Muelle sujecion cuna LF-7		4	-	-			
9	P510201	Muelle sujecion cuna LF-10		-	4	-			
9	P520201	Muelle sujecion cuna LF-14		-	-	4			
10	P530210	Pasador muelles		8	8	8			
11	Q352015	Pasador de aletas Ø3x30		16	16	16			
12	Q221306	Tuerca exagonal autoseguro M-10		8	8	8			
13	Q232060	Arandela plana A-10		40	40	40			
14	P530213	Amortiguador		4	4	4			
15	Q151326	Tornillo exagonal M-10x55		8	8	8			
16	P500202	Cuna LF-7		1	-	-			
16	P510202	Cuna LF-10		-	1	-			
16	P520202	Cuna LF-14		-	-	1			
17	Q151341	Tornillo exagonal M-12x35		4	4	-			
17	Q011387	Tornillo exagonal M-14x50		-	-	4			
18	Q301313	Arandela plana Ø38xØ12x3		8	8	-			
18	Q301380	Arandela plana A-15		-	-	8			
19	Q221307	Tuerca exagonal autoseguro M-12		4	4	-			

MOD.

LAVADORAS ALTAS REVOLUCIONES

ZONA

AMORTIGUACION Y FRENTE

PLANO

C-1146

ITEM	CODIGO	DENOMINACION	TEXTO	LF-7	LF-10	LF-14			NOTAS
19	Q221338	Tuerca exagonal autoseguro M-14		-	-	4			
20	P516103	Anillo anterior cuba LF-7 y 10		1	1	-			
20	P526108	Anillo anterior cuba LF-14		-	-	1			
21	P506106	Cuba LF-7		1	-	-			
21	P516105	Cuba LF-10		-	1	-			
21	P526105	Cuba LF-14		-	-	1			
22	Q012056	Tornillo exagonal M-8x40		1	1	1			
23	Q221309	Tuerca exagonal autoseguro M-8		1	1	1			
24	P500511	Soporte bisagra		1	1	1			
25	Q222012	Tuerca exagonal autoblocante M-6		4	4	4			
26	Q032031	Tornillo alomado M-5x10		4	4	4			
27	P520332	Fondo puerta		1	1	1			
28	3673700	Perfil goma gris en "U" 12x6x1350		1	1	1			
29	3703500	Perfil goma en "Y" 16x3x1300		1	1	1			
30	Q012031	Tornillo exagonal M-5x10		2	2	2			
31	Q242030	Arandela abanico A-5		2	2	2			
32	Q302022	Arandela plana Ø16x6x1,2		2	2	2			
33	P510324	Soporte frontal superior		1	1	-			
33	P520343	Soporte cubierta contrapeso		-	-	2			
34	Q221342	Remache exagonal M-5		2	2	2			
35	Q242030	Arandela abanico A-5		3	3	6			
36	Q032031	Tornillo alomado M-5x10		3	3	6			
37	P510321	Cubierta contrapeso LF-7 y 10		1	1	-			
37	P520323	Cubierta contrapeso LF-14		-	-	1			
38	Q302022	Arandela plana Ø16x6x1,2		2	2	2			
39	Q242030	Arandela abanico A-5		2	2	2			
40	Q012031	Tornillo exagonal M-5x10		2	2	2			

N. plano  
C-1147



Fecha  
4-2002

Aparato  
LAVADORAS LF-7, 10, 14

Laminio  
3

Frigor Industrial S. Coop. **FRIGOR**

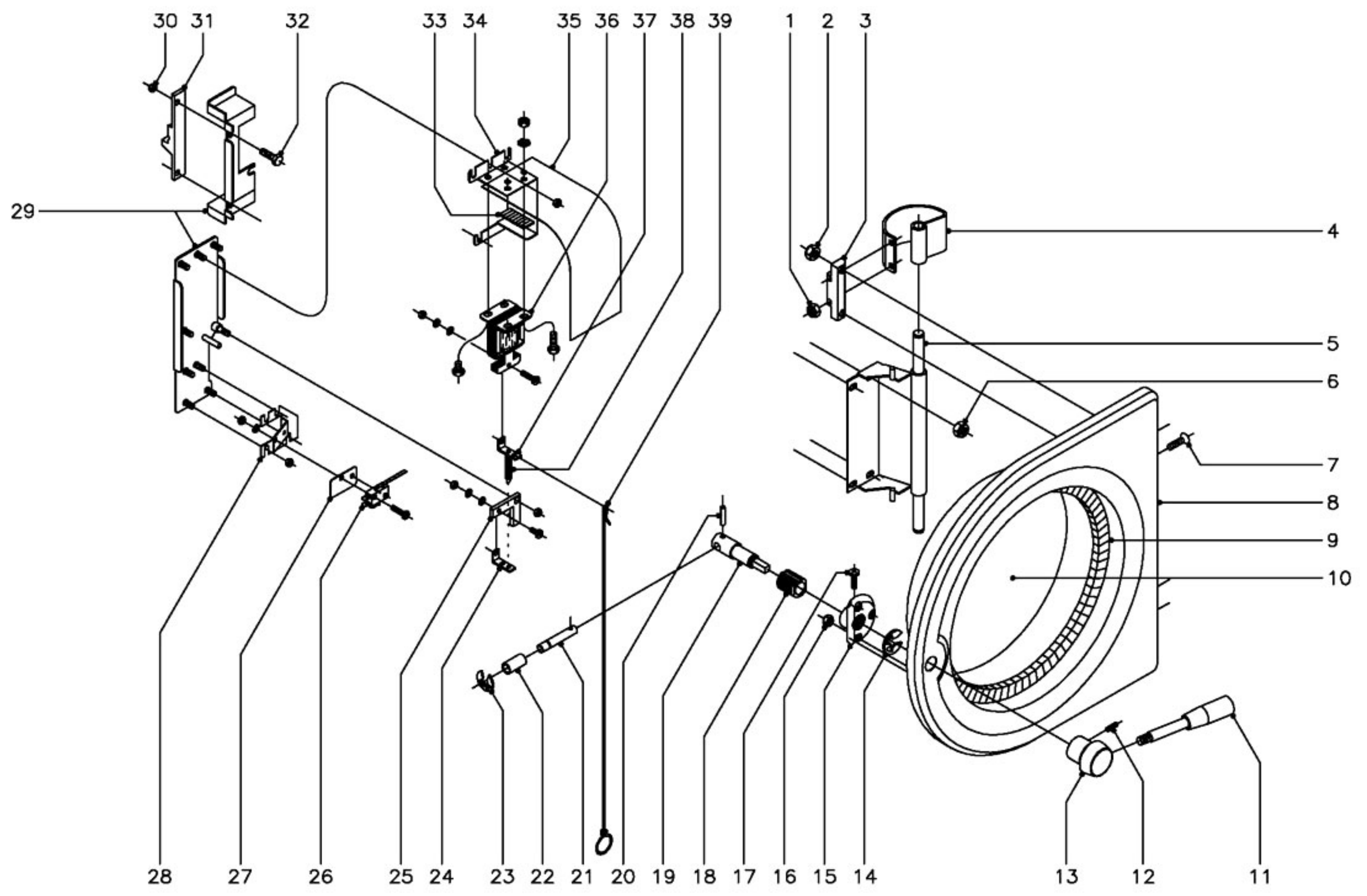



**MOD.****LAVADORAS ALTAS REVOLUCIONES****ZONA****PUERTA****PLANO****C-1147**

<b>ITEM</b>	<b>CODIGO</b>	<b>DENOMINACION</b>	<b>TEXTO</b>	<b>LF-7</b>	<b>LF-10</b>	<b>LF-14</b>	<b>NOTAS</b>
1	Q222030	Tuerca autoblocante M-5		4	4	4	
2	Q222012	Tuerca autoblocante M-6		4	4	4	
3	P500504	Sujecion bisagra		2	2	2	
4	P500502	Bisagra puerta		2	2	2	
5	P500511	Soporte bisagra		1	1	1	
6	Q222012	Tuerca autoblocante M-6		4	4	4	
7	Q062035	Tornillo allem 3 avellanado M-5x30		4	4	4	
8	P520508	Marco puerta		1	1	1	
9	P440502	Junta de puerta		1	1	1	
10	P440503	Mirilla puerta		1	1	1	
11	P520512	Palanca cierre puerta		1	1	1	
12	Q132042	Varilla roscada M-6x15		1	1	1	
13	P520513	Casquillo palanca cierre puerta		1	1	1	
14	Q271031	Anillo seguridad A-9		1	1	1	
15	P520515	Soporte cojinete guia		1	1	1	
16	Q222012	Tuerca autoblocante M-6		3	3	3	
17	Q152015	Tornillo alomado M-3x6		1	1	1	
18	P520503	Cojinete guia		1	1	1	
19	P520500	Eje palanca cierre		1	1	1	
20	Q371033	Manguito sujecion Ø3x12		1	1	1	
21	P530542	Eje tope		1	1	1	
22	P530544	Casquillo cierre		1	1	1	
23	Q301043	Anillo seguridad A-10		1	1	1	
24	P530559	Empalme muelle		1	1	1	
	Q032011	Tornillo alomado M-3x10		1	1	1	
	Q231310	Arandela plana A-3		1	1	1	
	Q242010	Arandela abanico A-3		1	1	1	
	Q161310	Tuerca exagonal M-3		1	1	1	
25	P530514	Tope cierre		1	1	1	

MOD.		LAVADORAS ALTAS REVOLUCIONES		ZONA	PUERTA		PLANO	C-1147
ITEM	CODIGO	DENOMINACION	TEXTO	LF-7	LF-10	LF-14	NOTAS	
	Q222012	Tuerca autoblocante M-6		1	1	1		
26	P530558	Microrruptor puerta		1	1	1		
	Q032013	Tornillo alomado M-3x20		2	2	2		
	Q242010	Arandela abanico A-3		2	2	2		
	Q161310	Tuerca exagonal M-3		2	2	2		
27	R010535	Placa separadora		1	1	1		
28	P530541	Soporte micro		1	1	1		
	Q222012	Tuerca autoblocante M-6		3	3	3		
29	-	Sujeciones del cierre		-	-	-	Soldados a cuba	
30	Q222012	Tuerca autoblocante M-6		2	2	2		
31	P530549	Pestillo		1	1	1		
32	Q012042	Tornillo exagonal M-6x15		2	2	2		
33	3714500	Perfil esponjoso adhesivo 20x2x40		1	1	1	Tope electroiman	
34	P510506	Sujecion electroiman		1	1	1		
	Q222012	Tuerca autoblocante M-6		4	4	4		
35	P530540	Cubierta electroiman		1	1	1		
36	P533046	Electroiman de puerta		1	1	1		
	Q012021	Tornillo exagonal M-4x10		4	4	4		
	Q242020	Arandela abanico A-4		4	4	4		
	Q162020	Tuerca exagonal M-4		4	4	4		
37	P530559	Empalme muelle		1	1	1		
	Q032011	Tornillo alomado M-3x20		1	1	1		
	Q231310	Arandela plana A-3		1	1	1		
	Q242010	Arandela abanico A-3		1	1	1		
	Q161310	Tuerca exagonal M-3		1	1	1		
38	P530531	Muelle electroiman		1	1	1		
39	P530507	Palanca apertura manual		1	1	1		

N.º plano C-1148  
 Firma   
 Fecha 4-2002  
 Aparato LAVADORAS LF-7, 10  
 PARTE FUNCIONAL MECANICA  
 Laminha 4  
 Fagor Industrial S. Coop.   
 Omitte

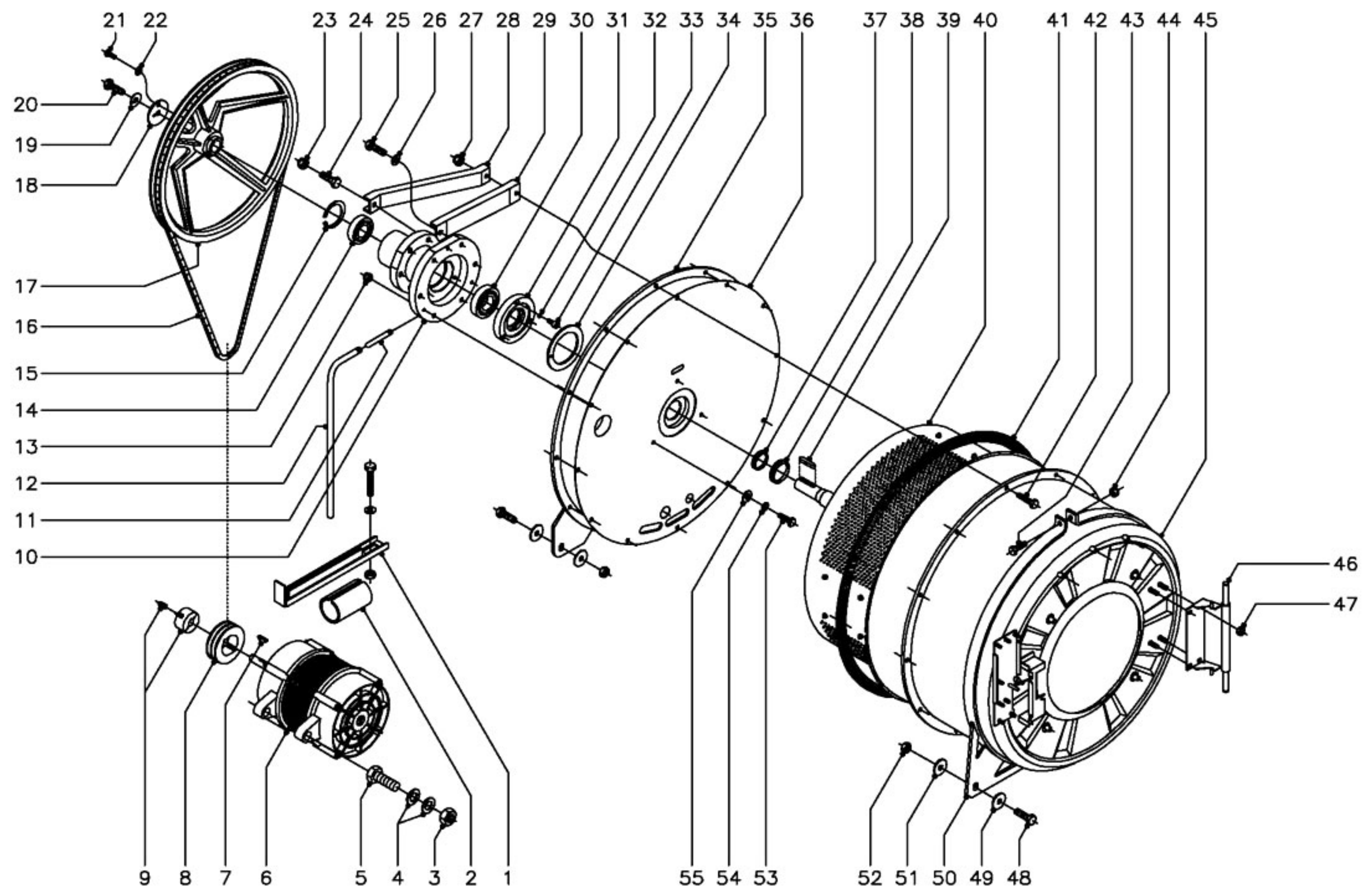

MOD.

LAVADORAS ALTAS REVOLUCIONES

ZONA

PARTE FUNCIONAL MECANICA

PLANO

C-1148

ITEM	CODIGO	DENOMINACION	TEXTO	LF-7	LF-10				NOTAS
1	P510207	Tensor de motor		1	1				
	Q151356	Tornillo exagonal M-10x110		1	1				
	Q232060	Arandela plana A-10		1	1				
	Q161360	Tuerca exagonal M-10		1	1				
2	P530218	Junta tensor motor		1	1				
3	Q221348	Tuerca exagon. autoblocante M-20		2	2				
4	Q231311	Arandela plana A-21		4	4				
5	Q151353	Tornillo exagonal M-20x70		2	2				
6	P505903	Motor 230/400 V. 50Hz.		1	-				
6	P515901	Motor 230/400 V. 50Hz.		-	1				
7	Q563005	Lengüeta parte redonda 5x9		1	1				
8	P505905	Polea motor		1	1				
9	P505904	Casquillo polea con tornillos		1	1				
10	P506001	Soporte rodamientos		1	-				
10	P516001	Soporte rodamientos		-	1				
11	P446019	Tubo Ø10xØ8x100		1	1				
12	3721900	Tubo transparente Ø12xØ10x400		1	1				
13	Q222012	Tuerca exagonal autoblocante M-6		3	3				
14	P446011	Rodamiento 6206-2ZC3		1	2				
15	Q301028	Anillo de seguridad Ø62x2		1	1				
16	P515903	Correa SPZ. LW-1700		2	2				
17	P506002	Polea tambor		1	1				
18	P446016	Arandela fijacion polea		1	1				
19	Q301329	Arandela de seguridad		1	1				
20	Q151341	Tornillo exagonal M-12x35		1	1				
21	Q032041	Tornillo alomado M-6x10		1	1				
22	Q242040	Arandela abanico A-6		1	1				
23	Q221306	Tuerca exagonal autoblocan. M-10		6	6				
24	Q151326	Tornillo exagonal M-10x55		6	6				
25	Q011364	Tornillo exagonal M-10x25		6	6				
26	Q232060	Arandela plana A-10		6	6				



MOD.

LAVADORAS ALTAS REVOLUCIONES

ZONA

PARTE FUNCIONAL MECANICA

PLANO

C-1148

ITEM	CODIGO	DENOMINACION	TEXTO	LF-7	LF-10				NOTAS
27	Q221309	Tuerca exagonal autoblocante M-8		12	12				
28	P446021	Refuerzo superior fondo cuba		6	6				
29	P446020	Refuerzo inferior fondo cuba		6	6				
30	P446010	Rodamiento 6207-2RSC3		1	2				
31	P516002	Casquillo retenes		1	1				
32	Q261030	Arandela muelle A-5		3	3				
33	Q122032	Tornillo allem M-5x15		3	3				
34	P456004	Junta retenes		1	1				
35	P516104	Anillo posterior soporte cuba		1	1				
36	P516004	Fondo de cuba		1	1				
37	P514922	Reten V-RING 40 A		1	1				
38	P514921	Reten V-RING 50 A		1	1				
39	P446017	Lengüeta de ajuste A8x7x45		1	1				
40	P504935	Tambor LF-7		1	-				
40	P514919	Tambor LF-10		-	1				
41	P506103	Junta de cuba		1	1				
42	Q012056	Tornillo exagonal M-8x40		12	12				
43	Q012056	Tornillo exagonal M-8x40		1	1				
44	Q221309	Tuerca exagonal autoblocante M-8		1	1				
45	P506106	Cuba LF-7		1	-				
45	P516105	Cuba LF-10		-	1				
46	P500511	Soporte bisagra		1	1				
47	Q222012	Tuerca exagonal autoblocante M-6		4	4				
48	Q151341	Tornillo exagonal M-12x35		4	4				
49	Q301313	Arandela plana Ø38xØ12x3		4	4				
50	P516103	Anillo anterior cuba LF-7 y 10		1	1				
51	Q301313	Arandela plana Ø38xØ12x3		4	4				
52	Q221307	Tuerca exagon. autoblocante M-12		4	4				
53	Q012046	Tornillo exagonal M-6x40		3	3				
54	Q232040	Arandela plana A-6		3	3				
55	Q304040	Arandela de estanq. Ø6,4xØ10,4x1		3	3				

N. plano  
C-1149



Fecha  
4-2002

Aparato

PARTE FUNCIONAL MECANICA  
LAVADORA LF-14

Laminha  
5

Opista

Fagor Industrial S. Coop. **FAGOR**

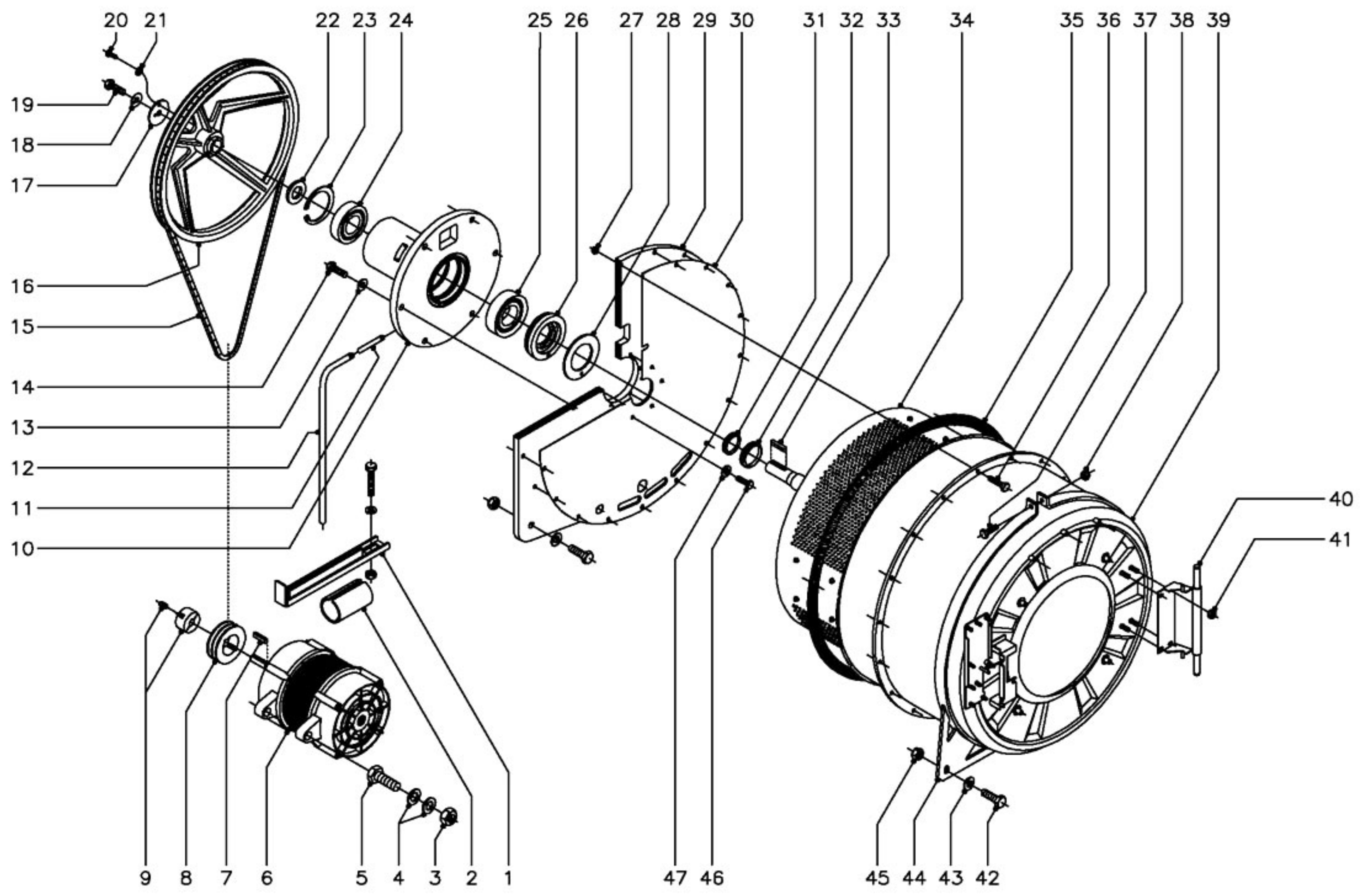

ITEM	CODIGO	DENOMINACION	TEXTO	LF-14					NOTAS
1	P520209	Tensor de motor		1					
	Q151326	Tornillo exagonal M-10x55		1					
	Q232060	Arandela plana A-10		1					
	Q161360	Tuerca exagonal M-10		1					
2	P530218	Junta tensor motor		1					
3	Q221348	Tuerca exagon. autoblocante M-20		2					
4	Q231311	Arandela plana A-21		4					
5	Q151353	Tornillo exagonal M-20x70		2					
6	P525907	Motor 230/400 V. 50Hz.		1					
7	P446017	Lengüeta A8x7x45 DIN-6885		1					
8	P505905	Polea motor		1					
9	P525904	Casquillo polea con tornillos		1					
10	P526001	Soporte rodamientos		1					
11	P446019	Tubo Ø10xØ8x100		1					
12	3721900	Tubo transparente Ø12xØ10x600		1					
13	Q301010	Arandela Ø27xØ12,5x2,5		6					
14	Q151341	Tornillo exagonal M-12x35		6					
15	P525906	Correa SPZ. LW-1900		2					
16	P506002	Polea tambor		1					
17	P446016	Arandela fijacion polea		1					
18	Q301329	Arandela de seguridad		1					
19	Q151341	Tornillo exagonal M-12x35		1					
20	Q032041	Tornillo alomado M-6x10		1					
21	Q242040	Arandela abanico A-6		1					
22	Q526005	Casquillo		1					
23	Q301030	Anillo de seguridad Ø90		1					
24	P305934	Rodamiento 6308 2Z		1					
25	P305933	Rodamiento 6309 2RS		1					
26	P526013	Casquillo soporte rodamientos		1					
27	Q221306	Tuerca exagon. Autoblocante M-10		18					
28	P456004	Junta retenes		1					
29	P526004	Plancha fondo cuba		1					
30	P526012	Fondo de cuba		1					
31	P524939	Reten V-RING 45A		1					
32	P524938	Reten V-RING 55A		1					
33	P446017	Lengüeta de ajuste A8x7x45		1					
34	P524940	Tambor LF-14		1					
35	P456105	Junta de cuba		1					
36	Q151326	Tornillo exagonal M-10x55		18					
37	Q012056	Tornillo exagonal M-8x40		1					
38	Q221309	Tuerca exagonal autoblocante M-8		1					
39	P526105	Cuba LF-14		1					
40	P500511	Soporte bisagra		1					
41	Q222012	Tuerca exagonal autoblocante M-6		4					
42	Q011387	Tornillo exagonal M-14x50		4					
43	Q301380	Arandela plana A-15		4					
44	P526108	Anillo anterior soporte cuba		1					
45	Q221338	Tuerca exagon. autoblocante M-14		4					
46	Q012042	Tornillo exagonal M-6x15		6					
47	Q304040	Arandela de cobre Ø10,4xØ6,4x1		6					



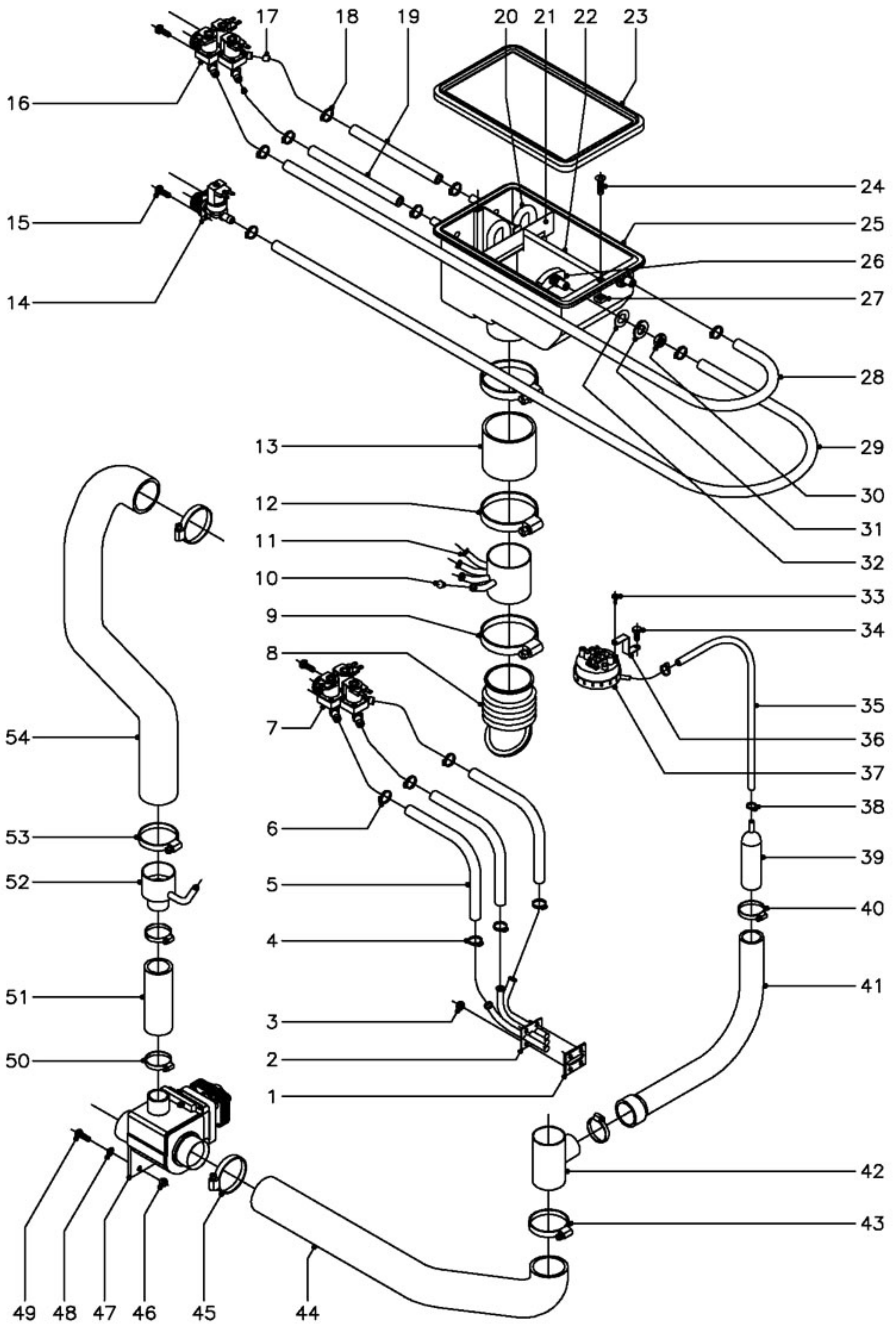

N plano  
C-1150

Firma

Fecha  
4-2002

Aparato  
LAVADORAS LF-7,10,14(Electromecanicas)

PARTE FUNCIONAL HIDRAULICA

Lamina  
6

Fagor Industrial S.Coop. **FAGOR**  
Ofete



MOD.

**LAVADORAS ALTAS REVOLUCIONES**  
 ( Electromecanicas )

ZONA

PARTE FUNCIONAL HIDRAULICA

PLANO

C-1150

ITEM	CODIGO	DENOMINACION	TEXTO	LF-7	LF-10	LF-14			NOTAS
1	P505003	Junta inyectoras		1	1	1			
2	P505006	Inyector completo		1	1	1			
3	Q222012	Tuerca exagonal autoblocante M-6		4	4	4			
4	Q881302	Abrazadera 12 - 20		3	3	3			
5	3676900	Tubo de goma Ø17xØ10x550		3	3	3			
6	Q881302	Abrazadera 12 - 20		3	3	3			
7	Z611123	Electrovalvula triple		1	1	1			
8	P440709	Conducto cubeta a cuba		1	1	1			
9	Q881335	Abrazadera 60 - 80		1	1	1			
10	P532116	Capucha dosificador		4	4	4			
11	P520700	Dosificador LF completo		1	1	1			
12	Q881326	Abrazadera 70 - 90		2	2	2			
13	P532108	Tubo de goma Ø86xØ76x90		1	1	1			
14	Z701135	Electrovalvula simple		1	1	1			
15	Q151320	Tornillo alomado M-4x6		6	6	6			
16	Z611123	Electrovalvula triple		1	1	1			
17	P443042	Regulador caudal (3l./m.)		2	2	2			
18	Q881302	Abrazadera 12 - 20		8	8	8			
19	3676900	Tubo de goma Ø17xØ10x550		2	2	2			
20	P440702	Tubo sifon		2	2	2			
21	P440715	Escuadra proteccion		1	1	1			
22	P440721	Perfil refuerzo		1	1	1			
23	P500702	Junta de cubeta		1	1	1			
24	Q152019	Tornillo avellanado M-4x15		2	2	2			
25	P440700	Cubeta de detergentes		1	1	1			
26	P440701	Difusor de detergentes		2	2	2			
27	Q222004	Tuerca cuadrada M-4		2	2	2			
28	3676900	Tubo de goma Ø17xØ10x700		1	-	-			
28	3676900	Tubo de goma Ø17xØ10x850		-	1	-			
28	3676900	Tubo de goma Ø17xØ10x900		-	-	1			

ITEM	CODIGO	DENOMINACION	TEXTO	LF-7	LF-10	LF-14			NOTAS
29	3676900	Tubo de goma Ø17xØ10x700		1	-	-			
29	3676900	Tubo de goma Ø17xØ10x850		-	1	-			
29	3676900	Tubo de goma Ø17xØ10x900		-	-	1			
30	Q223018	Tuerca exagonal M-16x1,5		2	2	2			
31	Q301302	Arandela plana A-17		2	2	2			
32	Q307002	Arandela junta		2	2	2			
33	Q082032	Tornillo alomado BZ-3,5x9,5		1	1	1			
34	Q032031	Tornillo alomado M-5x10		1	1	1			
35	3702400	Tubo goma negra Ø8xØ4x1000		1	1	1			
36	P503068	Soporte presostato		1	1	1			
37	P503008	Presostato de nivel		1	1	1			
38	Z704061	Brida cremallera		2	2	2			
39	P445002	Camara presostato		1	1	1			
40	Q881306	Abrazadera 32 - 50		2	2	2			
41	P445001	Codo de presostato		1	1	1			
42	-	Toma presion		1	1	1			Soldado a cuba
43	Q881324	Abrazadera 50 - 70		1	1	1			
44	P455000	Conducto desagüe		1	1	-			
44	P445005	Conducto rebosadero ( desagüe )		-	-	1			
45	Q881324	Abrazadera 50 - 70		1	1	1			
46	Q162030	Tuerca exagonal M-5		2	2	2			
47	P302120	Valvula vaciado		1	1	1			
48	Q302022	Arandela plana Ø16xØ6x1,2		2	2	2			
49	Q012032	Tornillo exagonal M-5x15		2	2	2			
50	Q881306	Abrazadera 32 - 50		2	2	2			
51	P502106	Tubo rebosadero		1	1	1			
52	P502101	Reduccion rebosadero		1	1	1			
53	Q881324	Abrazadera 50 - 70		2	2	2			
54	P445005	Conducto rebosadero		1	1	1			

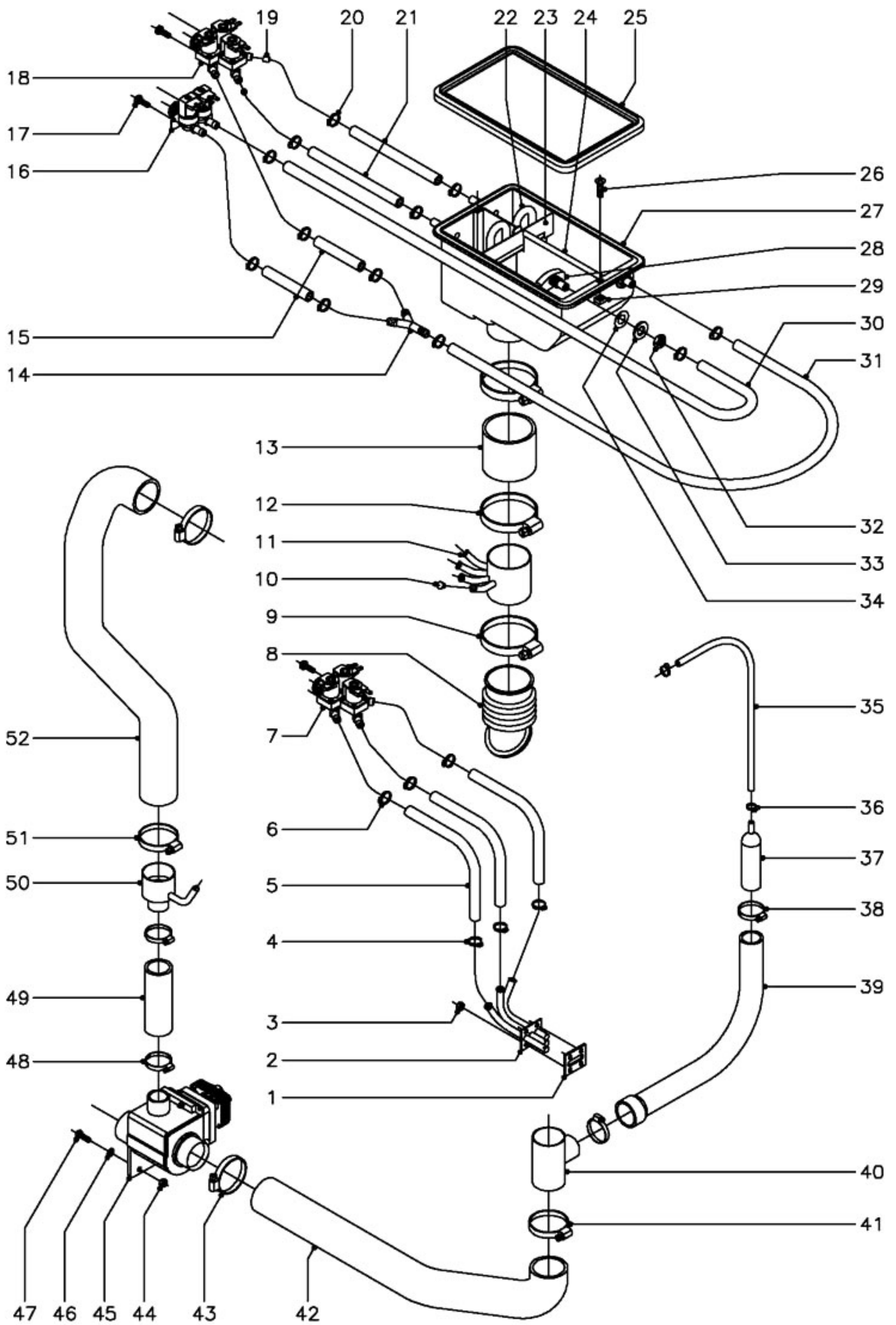

N plano  
C-1151

Firma

Fecha  
4-2002

Aparato  
PARTE FUNCIONAL HIDRAULICA  
LAVADORAS LF-7,10,14 (Electronicas)

Lamina  
7

Fagor Industrial S.Coop. **FAGOR**  
Ofeta

MOD.

**LAVADORAS ALTAS REVOLUCIONES  
( Electronicas )**

ZONA

PARTE FUNCIONAL HIDRAULICA

PLANO

C-1151

ITEM	CODIGO	DENOMINACION	TEXTO						NOTAS	
				LF-7 MP	LF-7 MPP	LF-10 MP	LF-10 MPP	LF-14 MP		LF-14 MPP
1	P505003	Junta inyectoros		1		1		1		
2	P505006	Inyector completo		1		1		1		
3	Q222012	Tuerca exagonal autoblocante M-6		4		4		4		
4	Q881302	Abrazadera 12 - 20		3		3		3		
5	3676900	Tubo de goma Ø17xØ10x550		3		3		3		
6	Q881302	Abrazadera 12 - 20		3		3		3		
7	Z611123	Electrovalvula triple		1		1		1		
8	P440709	Conducto cubeta a cuba		1		1		1		
9	Q881335	Abrazadera 60 - 80		1		1		1		
10	P532116	Capucha dosificador		4		4		4		
11	P520700	Dosificador LF completo		1		1		1		
12	Q881326	Abrazadera 70 - 90		2		2		2		
13	P532108	Tubo de goma Ø86xØ76x90		1		1		1		
14	Z201106	Racord en "Y"		1		1		1		
15	3676900	Tubo de goma Ø17xØ10x200		2		2		2		
16	P255001	Electrovalvula doble		1		1		1		
17	Q151320	Tornillo alomado M-4x6		6		6		6		
18	Z611123	Electrovalvula triple		1		1		1		
19	P443042	Regulador caudal (3l./m.)		2		2		2		
20	Q881302	Abrazadera 12 - 20		8		8		8		
21	3676900	Tubo de goma Ø17xØ10x550		2		2		2		
22	P440702	Tubo sifon		2		2		2		
23	P440715	Escuadra proteccion		1		1		1		
24	P440721	Perfil refuerzo		1		1		1		
25	P500702	Junta de cubeta		1		1		1		
26	Q152019	Tornillo avellanado M-4x15		2		2		2		
27	P440700	Cubeta de detergentes		1		1		1		
28	P440701	Difusor de detergentes		2		2		2		
29	Q222004	Tuerca cuadrada M-4		2		2		2		



MOD.

**LAVADORAS ALTAS REVOLUCIONES**  
**( Electronicas )**

ZONA

**PARTE FUNCIONAL HIDRAULICA**

PLANO

C-1151

ITEM	CODIGO	DENOMINACION	TEXTO	LF-7 MP	LF-7 MPP	LF-10 MP	LF-10 MPP	LF-14 MP	LF-14 MPP			NOTAS
30	3676900	Tubo de goma Ø17xØ10x700		1	-	-						
30	3676900	Tubo de goma Ø17xØ10x850		-	1	-						
30	3676900	Tubo de goma Ø17xØ10x900		-	-	1						
31	3676900	Tubo de goma Ø17xØ10x700		1	-	-						
31	3676900	Tubo de goma Ø17xØ10x850		-	1	-						
31	3676900	Tubo de goma Ø17xØ10x900		-	-	1						
32	Q223018	Tuerca exagonal M-16x1,5		2	2	2						
33	Q301302	Arandela plana A-17		2	2	2						
34	Q307002	Arandela junta		2	2	2						
35	3702400	Tubo goma negra Ø8xØ4x1000		1	1	1						
36	Z704061	Brida cremallera		2	2	2						
37	P445002	Camara presostato		1	1	1						
38	Q881306	Abrazadera 32 - 50		2	2	2						
39	P445001	Codo de presostato		1	1	1						
40	-	Toma presion		1	1	1						Soldado a cuba
41	Q881324	Abrazadera 50 - 70		1	1	1						
42	P455000	Conducto desagüe		1	1	-						
42	P445005	Conducto rebosadero ( desagüe )		-	-	1						
43	Q881324	Abrazadera 50 - 70		1	1	1						
44	Q162030	Tuerca exagonal M-5		2	2	2						
45	P302120	Valvula vaciado		1	1	1						
46	Q302022	Arandela plana Ø16xØ6x1,2		2	2	2						
47	Q012032	Tornillo exagonal M-5x15		2	2	2						
48	Q881306	Abrazadera 32 - 50		2	2	2						
49	P502106	Tubo rebosadero		1	1	1						
50	P502101	Reduccion rebosadero		1	1	1						
51	Q881324	Abrazadera 50 - 70		2	2	2						
52	P445005	Conducto rebosadero		1	1	1						

N.º plano  
C-1152



Ficha  
4-2002

Apartado  
LAVADORAS LF-7,10,14 (Electromecánicas)

Laminas  
8

Faber Industrial S. Coop. **FAOR**

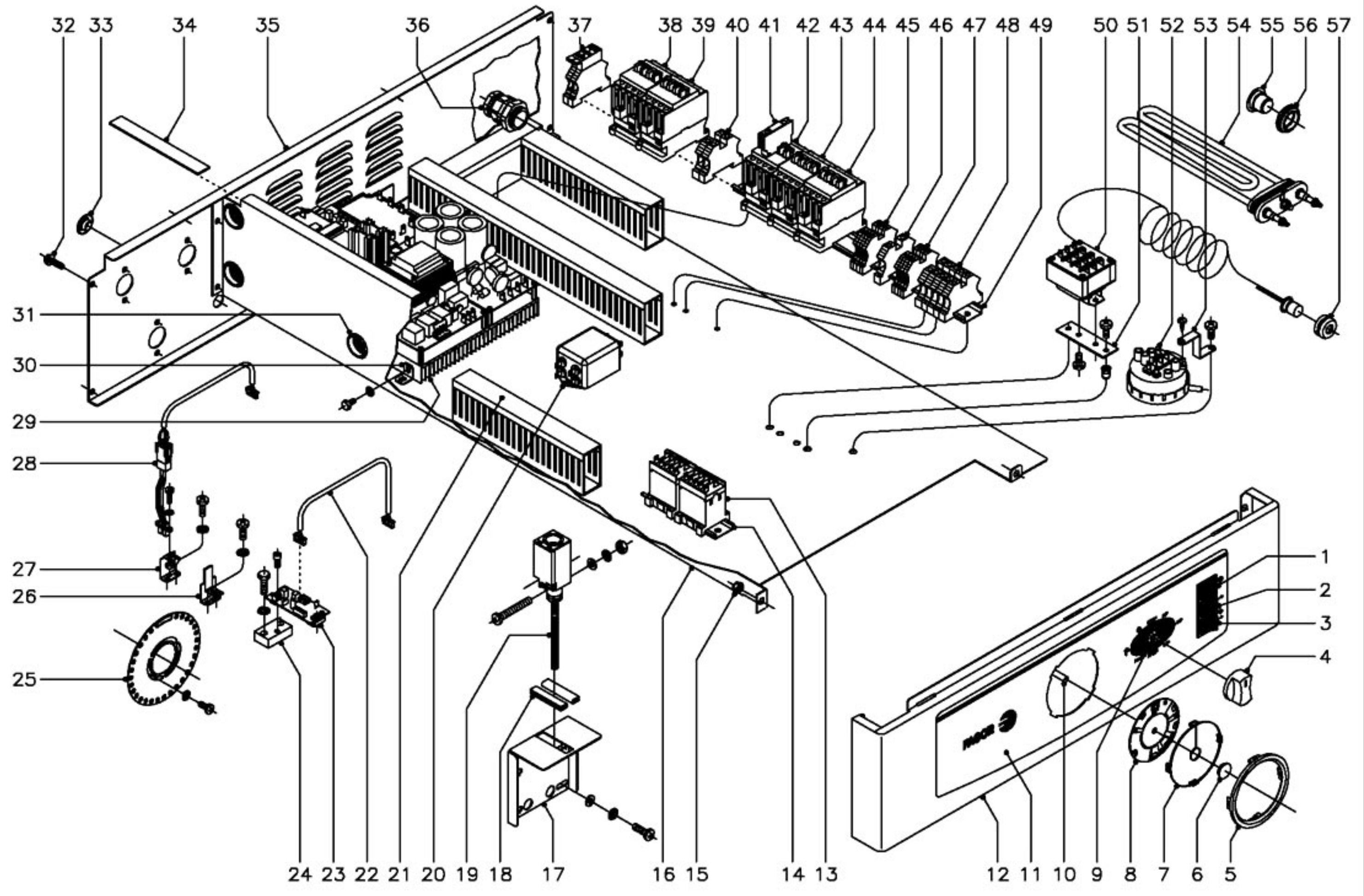

MOD.

**LAVADORAS ALTAS REVOLUCIONES**  
 ( Electromecanicas )

ZONA

PARTE FUNCIONAL ELECTRICA

PLANO

C-1152

ITEM	CODIGO	DENOMINACION	TEXTO	LF-7	LF-10	LF-14			NOTAS
1	P503004	Piloto rojo		1	1	1			
2	P503005	Pulsador verde (puerta)		1	1	1			
3	P503006	Pulsador blanco (avance)		1	1	1			
4	R663062	Boton de mando completo		1	1	1			
5	P440336	Marco mirilla		1	1	1			
6	P302882	Embellecedor disco programador		1	1	1			
7	P500315	Mirilla de disco		1	1	1			
8	P500314	Disco programador		1	1	1			
9	P433023	Conmutador 8 posiciones		1	1	1			
	Z602906	Casquillo distanciador		2	2	2			Amarre conmutador
	Q041324	Tornillo avellanado M-4x25		2	2	2			Amarre conmutador
10	P433004	Programador rotativo		1	1	1			
	Q151320	Tornillo alomado M-4x6		2	2	2			Amarre programador
	Q242020	Arandela abanico A-4		2	2	2			Amarre programador
11	P500310	Embellecedor portamandos		1	1	1			
12	P510312	Portamandos program. Mecanico		1	1	-			
12	P520326	Portamandos program. Mecanico		-	-	1			
13	Z683087	Contactador 230 V.		2	2	2			
14	Z103084	Guia contactor L=138		1	1	1			
15	Q222012	Tuerca exagonal autoblocante M-6		3	3	3			
16	P503067	Soporte cuadro electrico LF-7		1	-	-			
16	P513003	Soporte cuadro electrico LF-10		-	1	-			
16	P523004	Soporte cuadro electrico LF-14		-	-	1			
17	P523005	Tope micro de seguridad		1	1	1			
	Q302022	Arandela plana Ø16xØ6x1,2		2	2	2			
	Q242030	Arandela abanico A-5		2	2	2			
	Q032031	Tornillo alomado M-5x10		2	2	2			
18	3673700	Perfil goma gris en "U" 12x6x50		2	2	2			
19	Z273016	Micro de seguridad		1	1	1			



MOD.

**LAVADORAS ALTAS REVOLUCIONES**  
 ( Electromecanicas )

ZONA

PARTE FUNCIONAL ELECTRICA

PLANO

C-1152

ITEM	CODIGO	DENOMINACION	TEXTO	LF-7	LF-10	LF-14			NOTAS
	Q031326	Tornillo alomado M-4x40		2	2	2			
	Q232030	Arandela plana A-5		2	2	2			
	Q242020	Arandela abanico A-4		2	2	2			
	Q221305	Tuerca exagonal autoblocante M-4		2	2	2			
20	P523018	Filtro interferencias		1	1	1			
	Q151323	Tornillo broca Ø4,8x16		2	2	2			
21	3715520	Canaleta unex 60x30xlongitud		8	8	8			
	Q419005	Remache tubular Ø4x8		14	14	14			
22	P503028	Cableado sensor		2	2	2			
23	P533016	Sensor galga liar		2	2	2			
	Q122032	Tornillo allem M-5x15		4	4	4			
24	P526006	Calzo sensor		-	-	2			
	Q242040	Arandela abanico A-6		-	-	4			
	Q012043	Tornillo exagonal M-6x20		-	-	4			
25	P506006	Disco detector		1	1	1			
	Q242020	Arandela abanico A-4		3	3	3			
	Q153021	Tornillo alomado M-4x10		3	3	3			
26	P526010	Soporte detector 14 Kg.		-	-	1			
	Q242020	Arandela abanico A-4		-	-	2			
	Q151320	Tornillo alomado M-4x6		-	-	2			
27	P506009	Soporte detector 7 y 10 Kg.		1	1	-			
	Q242020	Arandela abanico A-4		2	2	-			
	Q151320	Tornillo alomado M-4x6		2	2	-			
28	P503027	Cableado detector		1	1	1			
	Q032011	Tornillo alomado M-3x10		1	1	1			
	Q242010	Arandela abanico A-3		2	2	2			
	Q162010	Tuerca exagonal M-3		1	1	1			
29	P503009	Convertidor V/F Liar		1	1	1			
30	P503012	Amarre convertidor		4	4	4			



MOD.

**LAVADORAS ALTAS REVOLUCIONES**  
 ( Electromecanicas )

ZONA

PARTE FUNCIONAL ELECTRICA

PLANO

C-1152

ITEM	CODIGO	DENOMINACION	TEXTO	LF-7	LF-10	LF-14			NOTAS
	Q242030	Arandela abanico A-5		8	8	8			
	Q152051	Tornillo exagonal M-5x6		8	8	8			
31	X723014	Pasamuros Ø 30		4	4	4			
32	Q151323	Tornillo broca Ø4,8x16		9	9	9			
33	P530335	Tapon soporte electrovalvulas		4	4	4			
34	3714500	Perfil esponjoso adhe. 20x2x1000		1	1	1			
35	P510320	Soporte electrovalvulas LF-7 y 10		1	1	-			
35	P520336	Soporte electrovalvulas LF-14		-	-	1			
36	R023013	Prensaestopas		1	1	1			
37	R073005	Borna portafusibles		2	2	2			
	P184011	Cartucho fusible 4 A.		2	2	2			
38	P433030	Contactador 3TF3001-OAL2 (230V.)		1	1	1			
39	P433030	Contactador 3TF3001-OAL2 (230V.)		1	1	1			
40	P453025	Borne paso 10 (gris)		2	2	2			
41	Z316328	Contacto auxiliar 1NC 3TX4001-2A		1	1	1			
42	P433030	Contactador 3TF3001-OAL2 (230V.)		1	1	1			
43	P433030	Contactador 3TF3001-OAL2 (230V.)		1	1	1			
44	P433030	Contactador 3TF3001-OAL2 (230V.)		1	1	1			
45	Z103029	Borne paso 2,5 (gris)		4	4	4			
46	P453026	Borne tierra 10 (amarillo-verde)		1	1	1			
47	Z103029	Borne paso 2,5 (gris)		4	4	4			
48	P453025	Borne paso 10 (gris)		3	3	3			
	Z263302	Borne neutro 10 (azul)		1	1	1			
	P453026	Borne tierra 10 (amarillo-verde)		1	1	1			
49	Z103083	Guia contactor L= 73		1	1	1			
	R663054	Guia contactor L= 320		1	1	1			
50	P433018	Termostato 4 tempera. Preselecci.		1	1	1			
	Q032021	Tornillo alomado M-4x10		2	2	2			
51	P453020	Sujecion termostato		1	1	1			

MOD.	LAVADORAS ALTAS REVOLUCIONES ( Electromecanicas )		ZONA	PARTE FUNCIONAL ELECTRICA			PLANO	C-1152
ITEM	CODIGO	DENOMINACION	TEXTO	LF-7	LF-10	LF-14		NOTAS
	Q032031	Tornillo alomado M-5x10		2	2	2		
	Q221342	Remache exagonal M-5		2	2	2		
52	P503008	Presostato de nivel		1	1	-		
52	P523002	Presostato de nivel		-	-	1		
	Q082032	Tornillo alomado BZ-3,5x9,5		1	1	1		
53	P503068	Soporte presostato		1	1	1		
	Q032031	Tornillo alomado M-5x10		1	1	1		
54	P103012	Resistencia 2000 W. 230 V.		3	-	-		
54	P143002	Resistencia 3000 W. 230 V.		-	3	-		
54	P183002	Resistencia 4000 W. 230 V.		-	-	3		
55	P443060	Tapon		1	1	1		
56	N503017	Soporte termostato		1	1	1		
57	Z703048	Pasamuros bulbo		1	1	1		

Pág. 30.

MOD.	LAVADORAS ALTAS REVOLUCIONES ( Electromecanicas )		ZONA	VARIOS	PLANO		
ITEM	CODIGO	DENOMINACION	TEXTO	LF-7	LF-10	LF-14	NOTAS
	P536528	Folleto de instrucciones		1	1	1	
	Z602121	Manguera entrada de agua		3	3	3	
	R189915	Taco Fisher de 10		4	4	4	Fijacion maquina
	Q151352	Tornillo 8x60		4	4	4	Fijacion maquina
	Q232050	Arandela A-8		4	4	4	Fijacion maquina
	P533053	Esquema electrico adhesivo		1	1	1	Plano HC-30860
	P533067	Leyenda esquema electrico		1	1	1	Plano HC-30886
	P523012	Instalacion electrica base		1	1	1	
	P523013	Instalacion altas revoluciones		1	1	1	
	P523007	Cableado a resistencias		1	1	1	
	P523008	Cableado a motor		1	1	1	
	P523009	Cableado regletas a contactores		2	2	2	
	P533061	Cableado a micro de seguridad		1	1	1	
	P513004	Cubierta cuadro electrico transpar.		1	1	-	
	P523017	Cubierta cuadro electrico transpar.		-	-	1	

Pág. 31.

N plano  
C-1153



Fecha  
4-2002

Aparato  
LAVADORAS LF-7,10,14 (Electrónicas)

Laminas  
9

Fagor Industrial S.Coop.  
DIRETA  
**FAGOR**

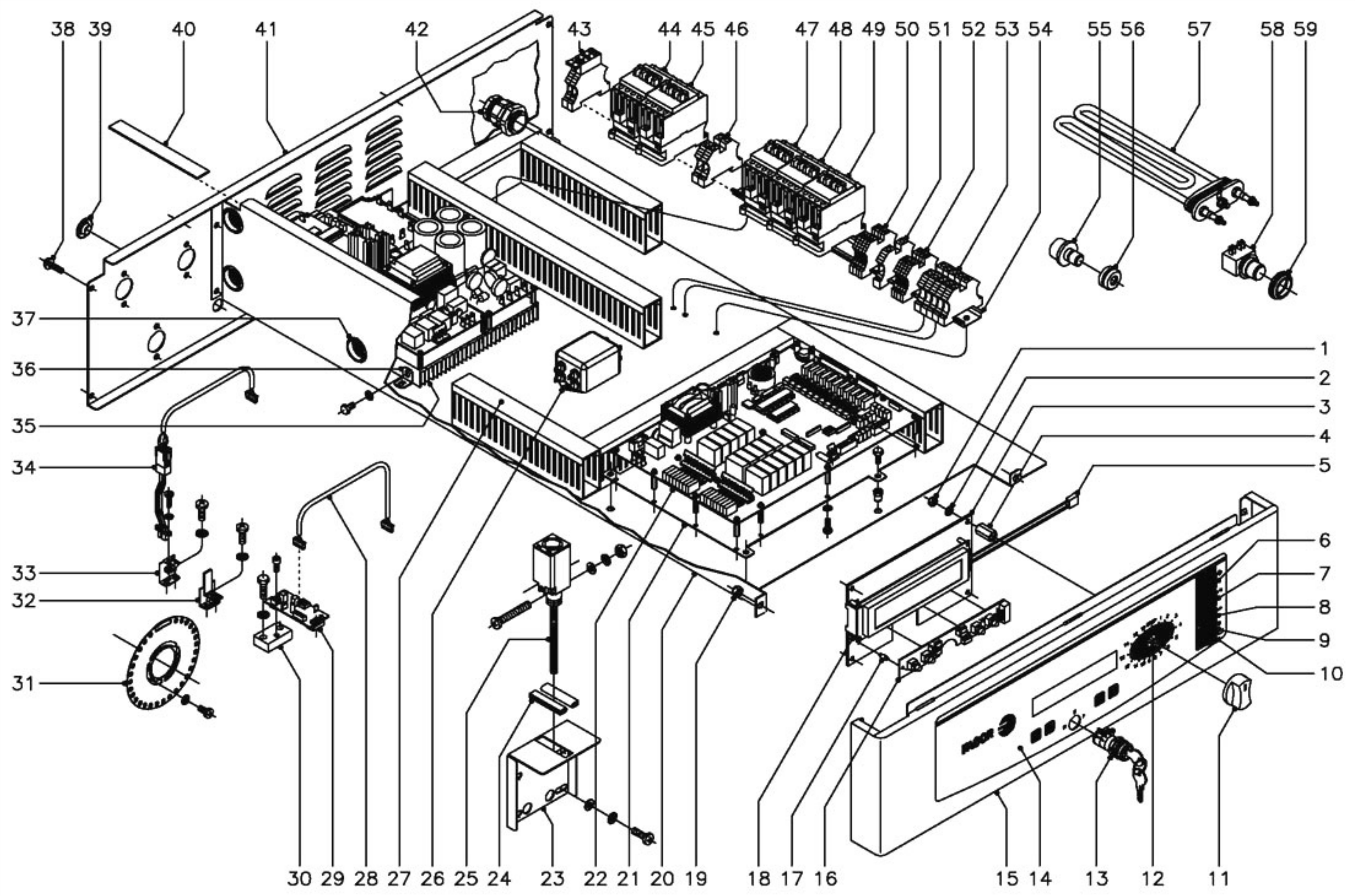



<b>MOD.</b>	<b>LAVADORAS ALTAS REVOLUCIONES ( Electronicas )</b>	<b>ZONA</b>	<b>PARTE FUNCIONAL ELECTRICA</b>	<b>PLANO</b>	<b>C-1153</b>
-------------	--	-------------	----------------------------------	--------------	---------------

<b>ITEM</b>	<b>CODIGO</b>	<b>DENOMINACION</b>	<b>TEXTO</b>	<b>LF-7 MP</b>	<b>LF-10 MP</b>	<b>LF-14 MP</b>	<b>LF-7 MPP</b>	<b>LF-10 MPP</b>	<b>LF-14 MPP</b>	<b>NOTAS</b>
1	Q162020	Tuerca exagonal M-4		4	4	4	4	4	4	
2	Q242020	Arandela abanico A-4		4	4	4	4	4	4	
3	P503052	Soporte display y teclado		1	1	1	1	1	1	
4	P503034	Casquillo distanciador		4	4	4	4	4	4	
5	P503050	Display completo		1	1	1	1	1	1	
6	Z213033	Pulsador marcha		1	1	1	1	1	1	
7	P503005	Pulsador verde (puerta)		1	1	1	1	1	1	
8	P503006	Pulsador blanco (avance)		1	1	1	1	1	1	
9	P503026	Interruptor ambar (sin centrifugado)		1	1	1	1	1	1	
10	P503026	Interruptor ambar (flot)		1	1	1	1	1	1	
11	R663062	Boton de mando completo		1	1	1	1	1	1	
12	P503029	Selector de programa		1	1	1	1	1	1	
	Q151320	Tornillo alomado M-4x6		2	2	2	2	2	2	
	Q242020	Arandela abanico A-4		2	2	2	2	2	2	
	P503037	Sujecion selector de programa		1	1	1	1	1	1	
	Q222012	Tuerca exagonal autoblocante M-6		2	2	2	2	2	2	
13	P503032	Interruptor a llave		-	-	-	1	1	1	
14	P500323	Embellecedor portamandos		1	1	1	-	-	-	
14	P500325	Embellecedor portamandos		-	-	-	1	1	1	
15	P510313	Portamandos program. Electronico		1	1	-	1	1	-	
15	P520327	Portamandos program. Electronico		-	-	1	-	-	1	
16	P503011	Teclado programador		-	-	-	1	1	1	
17	P503045	Separador teclado		-	-	-	4	4	4	
18	P503043	Separador display		4	4	4	4	4	4	
19	Q222012	Tuerca exagonal autoblocante M-6		3	3	3	3	3	3	
20	P503067	Soporte cuadro electrico LF-7		1	-	-	1	-	-	
20	P513003	Soporte cuadro electrico LF-10		-	1	-	-	1	-	
20	P523004	Soporte cuadro electrico LF-14		-	-	1	-	-	1	
21	P503051	Suplemento cuadro electrico		1	1	1	1	1	1	



ITEM	CODIGO	DENOMINACION	TEXTO	LF-7 MP	LF-10 MP	LF-14 MP	LF-7 MPP	LF-10 MPP	LF-14 MPP	NOTAS
	Q012031	Tornillo exagonal M-5x10		4	4	4	4	4	4	
	Q221342	Remache exagonal M-5		4	4	4	4	4	4	
22	P503010	Programador electronico		1	1	1	1	1	1	
	Q152015	Tornillo alomado M-3x6		14	14	14	14	14	14	
	Q242010	Arandela abanico A-3		14	14	14	14	14	14	
23	P523005	Tope micro de seguridad		1	1	1	1	1	1	
	Q302022	Arandela plana Ø16xØ6x1,2		2	2	2	2	2	2	
	Q242030	Arandela abanico A-5		2	2	2	2	2	2	
	Q032031	Tornillo alomado M-5x10		2	2	2	2	2	2	
24	3673700	Perfil goma gris en "U" 12x6x50		2	2	2	2	2	2	
25	Z273016	Micro de seguridad		1	1	1	1	1	1	
	Q031326	Tornillo alomado M-4x40		2	2	2	2	2	2	
	Q232030	Arandela plana A-5		2	2	2	2	2	2	
	Q242020	Arandela abanico A-4		2	2	2	2	2	2	
	Q221305	Tuerca exagonal autoblocante M-4		2	2	2	2	2	2	
26	P523018	Filtro interferencias		1	1	1	1	1	1	
	Q151323	Tornillo broca Ø4,8x16		2	2	2	2	2	2	
27	3715520	Canaleta unex 60x30xlongitud		8	8	8	8	8	8	
	Q419005	Remache tubular Ø4x8		14	14	14	14	14	14	
28	P503028	Cableado sensor		2	2	2	2	2	2	
29	P533016	Sensor galga liar		2	2	2	2	2	2	
	Q122032	Tornillo allem M-5x15		4	4	4	4	4	4	
30	P526006	Calzo sensor		-	-	2	-	-	2	
	Q242040	Arandela abanico A-6		-	-	4	-	-	4	
	Q012043	Tornillo exagonal M-6x20		-	-	4	-	-	4	
31	P506006	Disco detector		1	1	1	1	1	1	
	Q242020	Arandela abanico A-4		3	3	3	3	3	3	
	Q153021	Tornillo alomado M-4x10		3	3	3	3	3	3	
32	P526010	Soporte detector 14 Kg.		-	-	1	-	-	1	

ITEM	CODIGO	DENOMINACION	TEXTO	LF-7 MP	LF-10 MP	LF-14 MP	LF-7 MPP	LF-10 MPP	LF-14 MPP	NOTAS
	Q242020	Arandela abanico A-4		-	-	2	-	-	2	
	Q151320	Tornillo alomado M-4x6		-	-	2	-	-	2	
33	P506009	Soporte detector 7 y 10 Kg.		1	1	-	1	1	-	
	Q242020	Arandela abanico A-4		2	2	-	2	2	-	
	Q151320	Tornillo alomado M-4x6		2	2	-	2	2	-	
34	P503027	Cableado detector		1	1	1	1	1	1	
	Q032011	Tornillo alomado M-3x10		1	1	1	1	1	1	
	Q242010	Arandela abanico A-3		2	2	2	2	2	2	
	Q162010	Tuerca exagonal M-3		1	1	1	1	1	1	
35	P503009	Convertidor V/F Liar		1	1	1	1	1	1	
36	P503012	Amarre convertidor		4	4	4	4	4	4	
	Q242030	Arandela abanico A-5		8	8	8	8	8	8	
	Q152051	Tornillo exagonal M-5x6		8	8	8	8	8	8	
37	X723014	Pasamuros Ø 30		4	4	4	4	4	4	
38	Q151323	Tornillo broca Ø4,8x16		9	9	9	9	9	9	
39	P530335	Tapon soporte electrovalvulas		4	4	4	4	4	4	
40	3714500	Perfil esponjoso adhe. 20x2x1000		1	1	1	1	1	1	
41	P510320	Soporte electrovalvulas LF-7 y 10		1	1	-	1	1	-	
41	P520336	Soporte electrovalvulas LF-14		-	-	1	-	-	1	
42	R023013	Prensaestopas		1	1	1	1	1	1	
43	R073005	Borna portafusibles		2	2	2	2	2	2	
	P184011	Cartucho fusible 4 A.		2	2	2	2	2	2	
44	P433030	Contactador 3TF3001-OAL2 (230V.)		1	1	1	1	1	1	
45	P433030	Contactador 3TF3001-OAL2 (230V.)		1	1	1	1	1	1	
46	P453025	Borne paso 10 (gris)		2	2	2	2	2	2	
47	P433030	Contactador 3TF3001-OAL2 (230V.)		1	1	1	1	1	1	
48	P433030	Contactador 3TF3001-OAL2 (230V.)		1	1	1	1	1	1	
49	P433030	Contactador 3TF3001-OAL2 (230V.)		1	1	1	1	1	1	
50	Z103029	Borne paso 2,5 (gris)		4	4	4	4	4	4	

MOD.		LAVADORAS ALTAS REVOLUCIONES ( Electronicas )		ZONA	PARTE FUNCIONAL ELECTRICA					PLANO	C-1153
ITEM	CODIGO	DENOMINACION	TEXTO	LF-7 MP	LF-10 MP	LF-14 MP	LF-7 MPP	LF-10 MPP	LF-14 MPP	NOTAS	
51	P453026	Borne tierra 10 (amarillo-verde)		1	1	1	1	1	1		
52	Z103029	Borne paso 2,5 (gris)		4	4	4	4	4	4		
53	P453025	Borne paso 10 (gris)		3	3	3	3	3	3		
	Z263302	Borne neutro 10 (azul)		1	1	1	1	1	1		
	P453026	Borne tierra 10 (amarillo-verde)		1	1	1	1	1	1		
54	Z103083	Guia contactor L= 73		1	1	1	1	1	1		
	R663054	Guia contactor L= 320		1	1	1	1	1	1		
55	P503024	Tapon		1	1	1	1	1	1		
56	Z703048	Pasamuros bulbo termostato		1	1	1	1	1	1		
57	P103012	Resistencia 2000 W. 230 V.		3	-	-	3	-	-		
57	P143002	Resistencia 3000 W. 230 V.		-	3	-	-	3	-		
57	P183002	Resistencia 4000 W. 230 V.		-	-	3	-	-	3		
58	P503025	Sonda temperatura cuba		1	1	1	1	1	1		
59	N503017	Soporte termostato		1	1	1	1	1	1		

Pág. 36.

MOD.		LAVADORAS ALTAS REVOLUCIONES ( Electronicas )		ZONA	VARIOS					PLANO	
ITEM	CODIGO	DENOMINACION	TEXTO	LF-7 MP	LF-10 MP	LF-14 MP	LF-7 MPP	LF-10 MPP	LF-14 MPP	NOTAS	
	P536527	Folleto de instrucciones		1	1	1	1	1	1		
	Z602121	Manguera entrada de agua		3	3	3	3	3	3		
	R189915	Taco Fisher de 10		4	4	4	4	4	4	Fijacion maquina	
	Q151352	Tornillo 8x60		4	4	4	4	4	4	Fijacion maquina	
	Q232050	Arandela A-8		4	4	4	4	4	4	Fijacion maquina	
	P533056	Esquema electrico adhesivo		1	1	1	1	1	1	Plano HC-30861	
	P533067	Leyenda esquema electrico		1	1	1	1	1	1	Plano HC-30886	
	P523007	Cableado a resistencias		1	1	1	1	1	1		
	P523008	Cableado a motor		1	1	1	1	1	1		
	P523009	Cableado regletas a contactores		2	2	2	2	2	2		
	P533061	Cableado a micro de seguridad		1	1	1	1	1	1		
	P523006	Instalacion electronica		1	1	1	1	1	1		
	P503046	Cableado conmutador electronico		1	1	1	1	1	1		
	P523011	Cableado programador electronico		1	1	1	1	1	1		
	P503048	Cableado conexión display		1	1	1	1	1	1		
	P523010	Cableado NTC		1	1	1	1	1	1		
	P503039	Cableado llave		-	-	-	1	1	1		
	P503040	Cable conexión tarjeta programad.		-	-	-	1	1	1		
	P513004	Cubierta cuadro electrico transpar.		1	1	-	1	1	-		
	P523017	Cubierta cuadro electrico transpar.		-	-	1	-	-	1		

Pág. 37.

N.º plano  
C-1154



Fecha  
4-2002

Aparato  
LAVADORAS  
VERSION VAPOR  
LF/V-7,10,14

Laminas  
10

Faber Industrial S. Coop.  
Oñate  
**FABER**

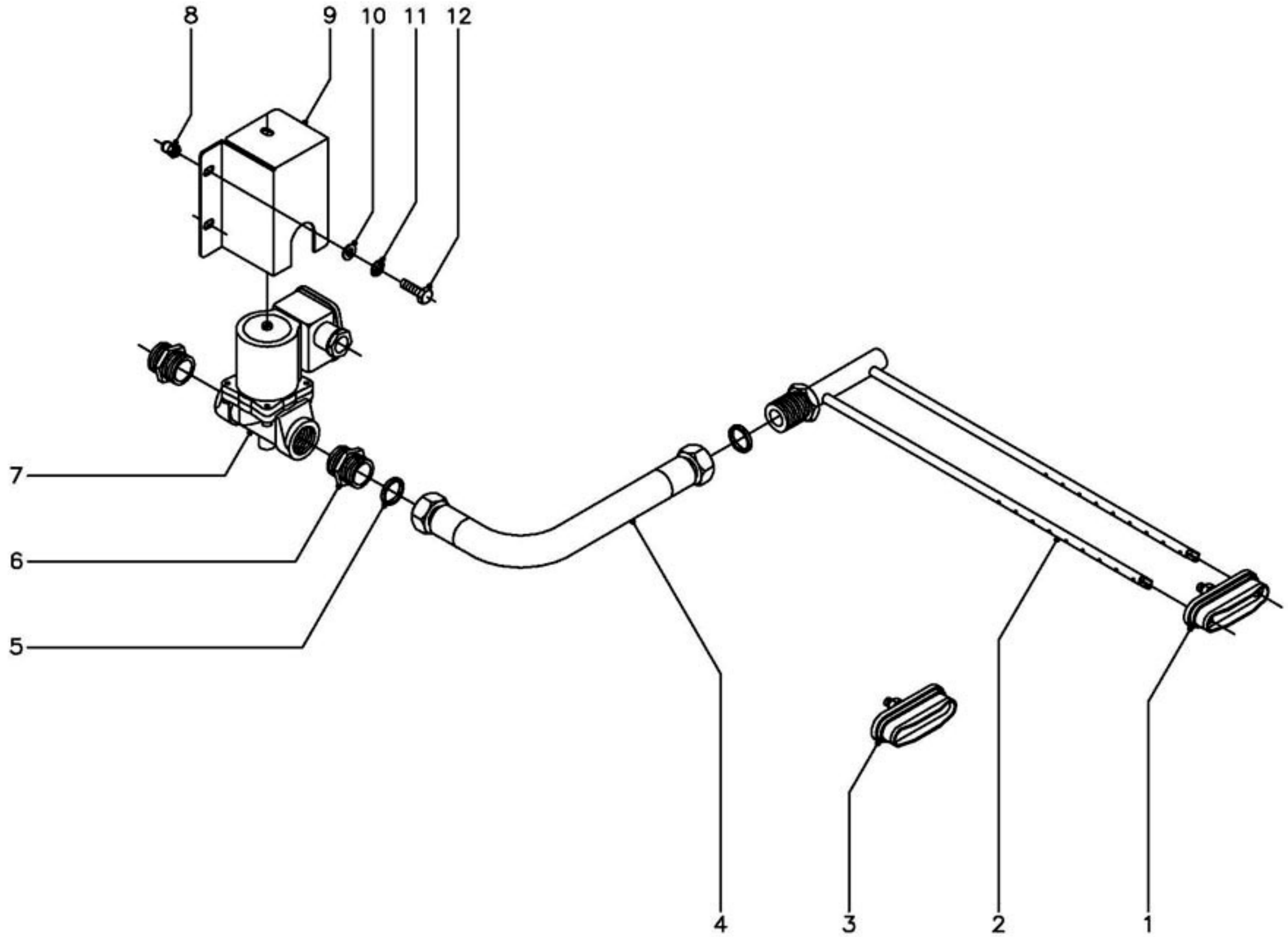



MOD.	LAVADORAS ALTAS REVOLUCIONES	ZONA	VERSION VAPOR	PLANO	C-1154
------	------------------------------	------	---------------	-------	--------

ITEM	CODIGO	DENOMINACION	TEXTO	LF/ E-7	LF/ E-10	LF/ E-14	LF/ V-7	LF/ V-10	LF/ V-14	NOTAS
		<b>SE ELIMINAN</b>								
	P103012	Resistencia 2000 W., 230V.		3	-	-	-	-	-	
	P143002	Resistencia 3000 W., 230V.		-	3	-	-	-	-	
	P183002	Resistencia 4000 W., 230V.		-	-	3	-	-	-	
	P433030	Contacto 3TF3001-OAL2 (230V.)		2	2	2	-	-	-	
	P523007	Cableado resistencias		1	1	1	-	-	-	
	P523009	Cableado regletas a contactores		2	2	2	-	-	-	
		<b>SE INTRODUCEN</b>								
1	P445011	Cierre completo		-	-	-	1	1	1	
2	P525000	Inyector de vapor completo		-	-	-	1	1	1	
3	P505008	Tapon cierre completo		-	-	-	2	2	2	
4	P525005	Latiguillo de vapor		-	-	-	1	1	1	
5	-	Arandela junta (con latiguillo)		-	-	-	2	2	2	
6	Z962205	Manguito doble 1/2"		-	-	-	2	2	2	
7	P525006	Electrovalvula vapor 1/2" ( 50 Hz.)		-	-	-	1	1	1	
8	Q221342	Remache exagonal M-5		-	-	-	2	2	2	
9	P505009	Soporte electrovalvula vapor		-	-	-	1	1	-	
9	P525002	Soporte electrovalvula vapor		-	-	-	-	-	1	
10	Q302022	Arandela plana Ø16xØ6x1,2		-	-	-	2	2	2	
11	Q242030	Arandela abanico A-5		-	-	-	2	2	2	
12	Q012032	Tornillo exagonal M-5x15		-	-	-	2	2	2	
s/n	P525007	Manguera de vapor L=1500		-	-	-	1	1	1	Maquina a red
s/n	P533054	Cableado electrovalvula vapor		-	-	-	1	1	1	

MOD.		LAVADORAS ALTAS REVOLUCIONES		ZONA	VERSION AGUA CALIENTE					PLANO	
ITEM	CODIGO	DENOMINACION	TEXTO	LF/E-7	LF/E-10	LF/E-14	LF/AC-7	LF/AC-10	LF/AC-14	NOTAS	
		<b>SE ELIMINAN</b>									
	P103012	Resistencia 2000 W., 230V.		2	-	-	-	-	-		
	P143002	Resistencia 3000 W., 230V.		-	2	-	-	-	-		
	P183002	Resistencia 4000 W., 230V.		-	-	2	-	-	-		
	P433030	Contactor 3TF3001-OAL2 (230V.)		1	1	1	-	-	-		
	P523007	Cableado resistencias		1	1	1	-	-	-		
	P523009	Cableado regletas a contactores		1	1	1	-	-	-		
		<b>SE INTRODUCEN</b>									
	P503055	Cableado resistencia (agua calie.)		-	-	-	1	1	1		
	P505008	Tapon cierre completo		-	-	-	2	2	2		

Pág. 40.

MOD.		LAVADORAS ALTAS REVOLUCIONES ( Electromecanicas de autoservicio )		ZONA	VERSION AUTOSERVICIO					PLANO	
ITEM	CODIGO	DENOMINACION	TEXTO	LF-7	LF-10	LF-14	LF-7 A	LF-10 A	LF-14 A	NOTAS	
		<b>SE ELIMINAN</b>									
	P500335	Panel lateral LF-7		1	-	-	-	-	-		
	P510316	Panel lateral LF-10		-	1	-	-	-	-		
	P520338	Panel lateral LF-14		-	-	1	-	-	-		
		<b>SE INTRODUCEN</b>									
	P500336	Panel lateral LF-7 A		-	-	-	1	-	-		
	P510318	Panel lateral LF-10 A		-	-	-	-	1	-		
	P520341	Panel lateral LF-14 A		-	-	-	-	-	1		
	P503053	Monedero		-	-	-	1	1	1		
	P503057	Instalacion electrica monedero		-	-	-	1	1	1		

Pág. 41.

MOD.		LAVADORAS ALTAS REVOLUCIONES ( Electromecanicas de autoservicio )		ZONA	VERSION ( 440 V., 50 Y 60Hz. SIN NEUTRO )					PLANO	
ITEM	CODIGO	DENOMINACION	TEXTO	LF/E-7	LF/E-10	LF/E-14				NOTAS	
		<b>SE INTRODUCEN</b>									
	P503059	Transformador 440 V. sin neutro		1	1	1					
	P503054	Instalacion electric. 440 V. s/neutro		1	1	1					

Pág. 42.