

**Lavadoras de centrifugado estándar
Laveuses à essorage standard
Washing machines
Washmaschinen
Lavatrici**



LAVANDERIA

Modelos:

**LC/E-7 // LC/AC-7 // LC/V-7
LC/E-10 // LC/AC-10 // LC/V-10
LC/E-14 // LC/AC-14 // LC/V-14**

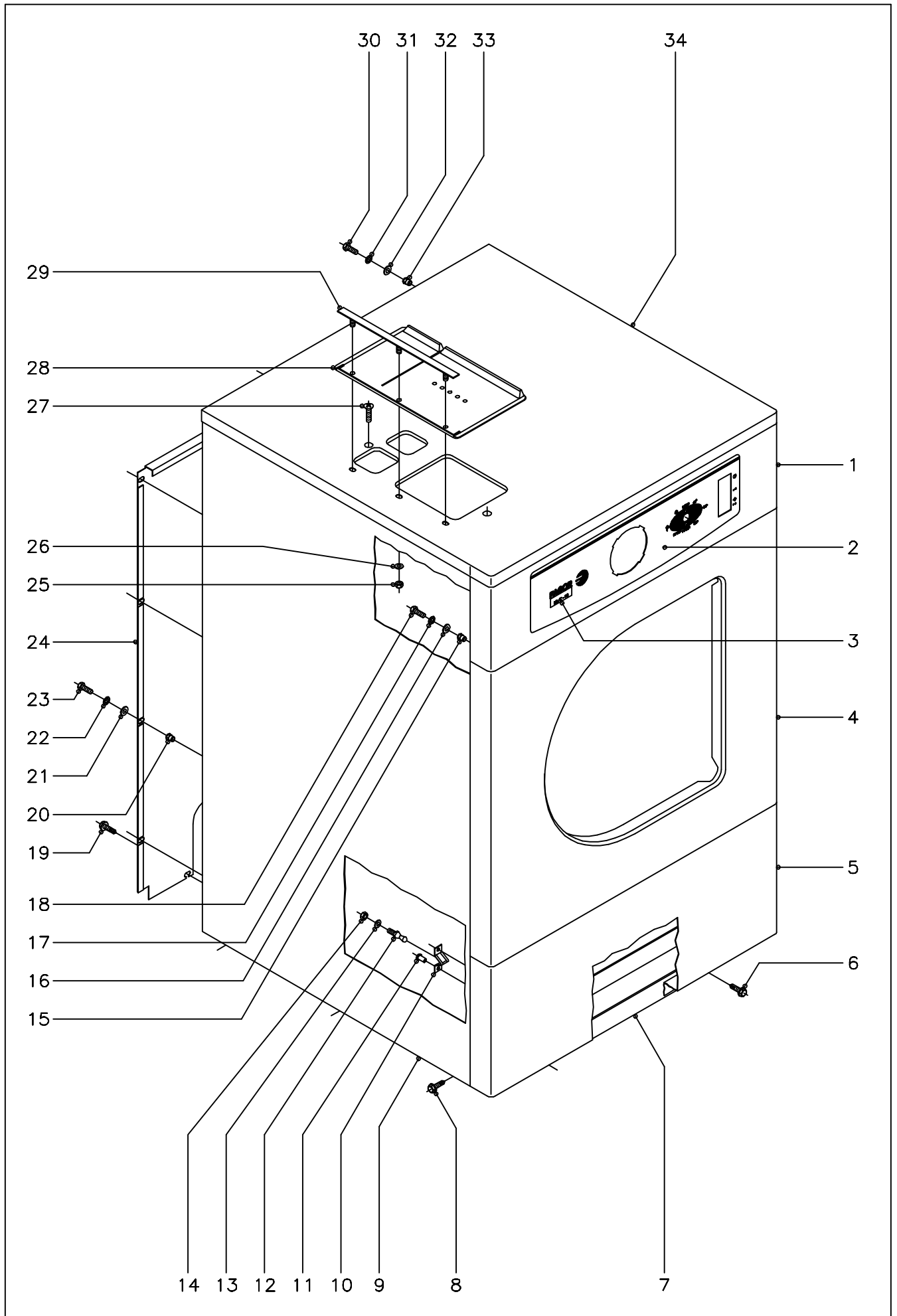
Abril 2002 April



N plano C-1155	Firma 	Fecha 5-2002	Aparato ARMAZON Y MUEBLE LAVADORAS LC-7,10,14	Lamina 1	Fagor Industrial S.Coop. FAGOR  Onote
-------------------	--	-----------------	---	-------------	--

MOD.	LAVADORAS LC	ZONA	ARMAZON Y MUEBLE	PLANO	C-1155
------	--------------	------	------------------	-------	--------

ITEM	CODIGO	DENOMINACION	TEXTO	LC-7	LC-10	LC-14							NOTAS
1	P500316	Portamandos		1	1	-							
1	P520310	Portamandos		-	-	1							
2	P500310	Embellecedor portama. mecanico		1	1	1							
3	P436510	Adhesivo modelo LC/E-7		1	-	-							
3	P436511	Adhesivo modelo LC/AC-7		1	-	-							
3	P436512	Adhesivo modelo LC/V-7		1	-	-							
3	P436513	Adhesivo modelo LC/E-7 A		1	-	-							
3	P436514	Adhesivo modelo LC/AC-7 A		1	-	-							
3	P436515	Adhesivo modelo LC/E-7(S.N.)		1	-	-							
3	P436516	Adhesivo modelo LC/E-7(60 Hz.)		1	-	-							
3	P436518	Adhesivo mod. LC/E-7(60 Hz.,S.N.)		1	-	-							
3	P446515	Adhesivo modelo LC/E-10		-	1	-							
3	P446516	Adhesivo modelo LC/AC-10		-	1	-							
3	P446517	Adhesivo modelo LC/V-10		-	1	-							
3	P446518	Adhesivo modelo LC/E-10 A		-	1	-							
3	P446519	Adhesivo modelo LC/AC-10 A		-	1	-							
3	P446520	Adhesivo modelo LC/E-10(S.N.)		-	1	-							
3	P446521	Adhesivo modelo LC/E-10(60 Hz.)		-	1	-							
3	P446522	Adhesivo mo. LC/E-10(60 Hz.,S.N.)		-	1	-							
3	P456510	Adhesivo modelo LC/E-14		-	-	1							
3	P456511	Adhesivo modelo LC/AC-14		-	-	1							
3	P456512	Adhesivo modelo LC/V-14		-	-	1							
3	P456513	Adhesivo modelo LC/E-14 A		-	-	1							
3	P456514	Adhesivo modelo LC/AC-14 A		-	-	1							
3	P456515	Adhesivo modelo LC/E-14(S.N.)		-	-	1							
3	P456516	Adhesivo modelo LC/E-14(60 Hz.)		-	-	1							
3	P456517	Adhesivo mo. LC/E-14(60 Hz.,S.N.)		-	-	1							
4	P500326	Panel frontal		1	1	-							
4	P520317	Panel frontal		-	-	1							

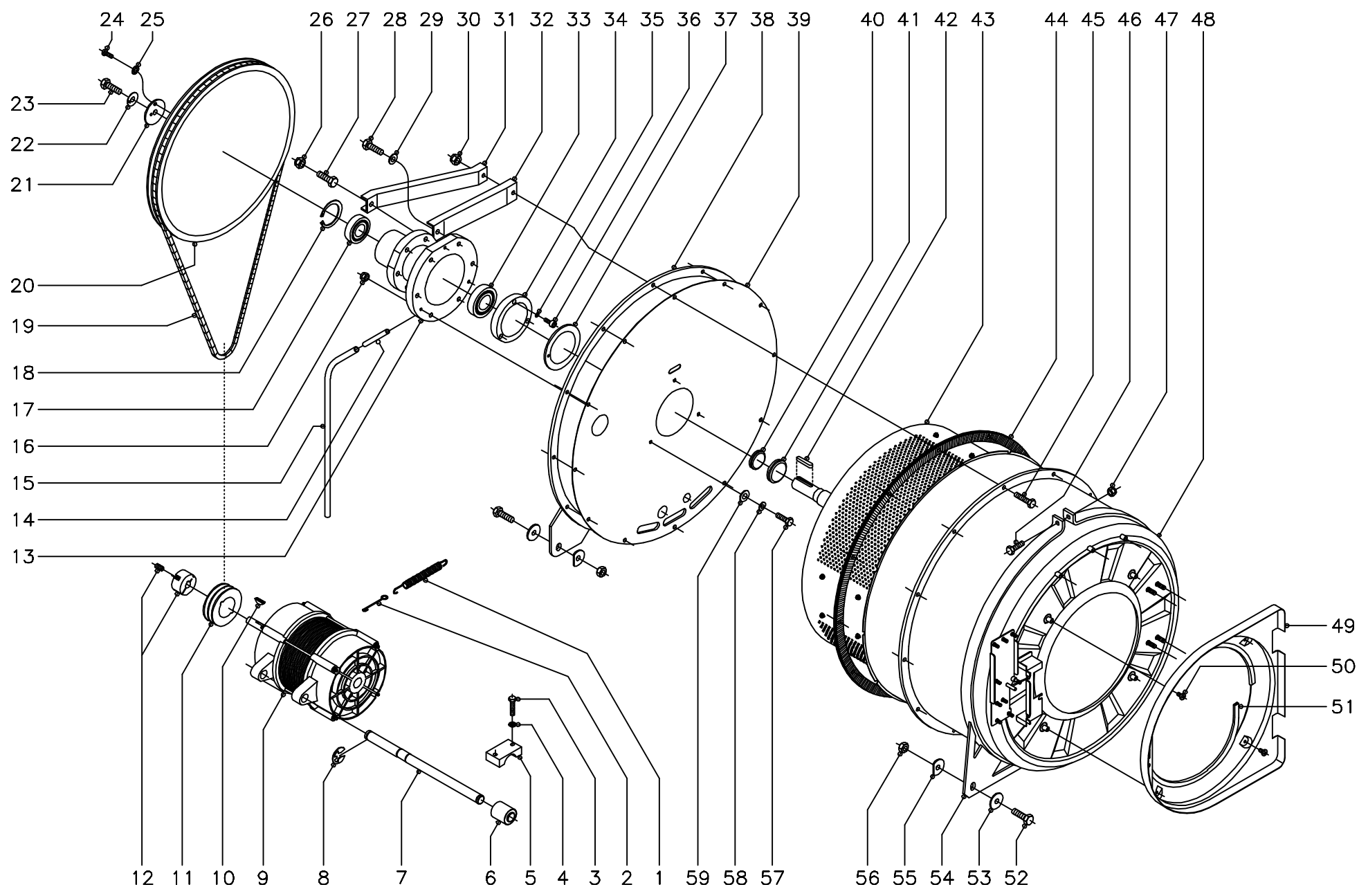

MOD.		LAVADORAS LC		ZONA	ARMAZON Y MUEBLE							PLANO	C-1155
ITEM	CODIGO	DENOMINACION	TEXTO	LC-7	LC-10	LC-14							NOTAS
5	P500309	Suplemento panel frontal		1	1	-							
5	P520314	Suplemento panel frontal		-	-	1							
6	Q151323	Tornillo broca Ø4,8x16		2	2	2							
7	P500101	Armazon completo		1	-	-							
7	P510101	Armazon completo		-	1	-							
7	P520101	Armazon completo		-	-	1							
8	Q151323	Tornillo broca Ø4,8x16		6	6	6							
9	P500300	Panel lateral completo		2	-	-							
9	P510300	Panel lateral completo		-	2	-							
9	P520300	Panel lateral completo		-	-	2							
10	X010503	Muelle enganche piton		2	2	2							
11	Q419007	Remache tubular Ø3,2x6		4	4	4							
12	P450303	Piton enganche		2	2	2							
13	Q232030	Arandela plana A-5		2	2	2							
14	Q221308	Tuerca exagonal autoblocante M-5		2	2	2							
15	Q221342	Remache exagonal M-5		6	6	6							
16	Q302022	Arandela plana Ø16xØ6x1,2		6	6	6							
17	Q242030	Arandela abanico A-5		6	6	6							
18	Q012031	Tornillo exagonal M-5x10		6	6	6							
19	Q151323	Tornillo broca Ø4,8x16		3	3	3							
20	Q221342	Remache exagonal M-5		8	8	8							
21	Q302022	Arandela plana Ø16xØ6x1,2		8	8	8							
22	Q242030	Arandela abanico A-5		8	8	8							
23	Q012031	Tornillo exagonal M-5x10		8	8	8							
24	P500324	Panel posterior		1	1	-							
24	P520315	Panel posterior		-	-	1							
25	Q162030	Tuerca exagonal M-5		3	3	3							
26	Q232030	Arandela plana A-5		3	3	3							
27	Q152019	Tornillo avellanado M-4x15		2	2	2							

N plano C-1156
 Fírmalo
 Fecha 5-2002
 Aparato LAVADORAS LC-7,10
 PARTE FUNCIONAL MECANICA
 Laminio 2
 Fagor Industrial S. Coop. Fagor
 Omite



MOD.		LAVADORAS LC		ZONA	PARTE FUNCIONAL MECANICA							PLANO	C-1156
ITEM	CODIGO	DENOMINACION	TEXTO	LC-7	LC-10								NOTAS
1	P445912	Resorte tensor de motor		1	1								
2	P445915	Alargadera resorte tensor		1	1								
3	Q012056	Tornillo exagonal M-8x40		4	4								
4	Q242050	Arandela abanico A-8		4	4								
5	P535909	Amarre superior amortiguacion		2	2								
6	P535910	Amortiguador motor		2	2								
7	P505902	Eje soporte motor		1	-								
7	P515902	Eje soporte motor		-	1								
8	Q271027	Arandela de seguridad Ø15		4	4								
9	P505903	Motor 230/400 V. 50Hz.		1	-								
9	P515901	Motor 230/400 V. 50Hz.		-	1								
10	Q563005	Lengüeta parte redonda 5x9		1	1								
11	P435903	Polea motor		1	1								
12	P435904	Casquillo polea con tornillos		1	1								
13	P506001	Soporte rodamientos		1	-								
13	P516001	Soporte rodamientos		-	1								
14	P446019	Tubo Ø10xØ8x100		1	1								
15	3721900	Tubo transparente Ø12xØ10x400		1	1								
16	Q222012	Tuerca exagonal autoblocante M-6		3	3								
17	P446011	Rodamiento 6206-2ZC3		1	2								
18	Q301028	Anillo de seguridad Ø62x2		1	1								
19	P445914	Correa SPZ. LW-1800		2	2								
20	P506002	Polea tambor		1	1								
21	P446016	Arandela fijacion polea		1	1								
22	Q301329	Arandela de seguridad		1	1								
23	Q151341	Tornillo exagonal M-12x35		1	1								
24	Q032041	Tornillo alomado M-6x10		1	1								
25	Q242040	Arandela abanico A-6		1	1								
26	Q221306	Tuerca exagonal autoblocan. M-10		6	6								

MOD.		LAVADORAS LC		ZONA	PARTE FUNCIONAL MECANICA							PLANO	C-1156
ITEM	CODIGO	DENOMINACION	TEXTO	LC-7	LC-10								NOTAS
27	Q151326	Tornillo exagonal M-10x55		6	6								
28	Q011364	Tornillo exagonal M-10x25		6	6								
29	Q232060	Arandela plana A-10		6	6								
30	Q221309	Tuerca exagonal autoblocante M-8		12	12								
31	P446021	Refuerzo superior fondo cuba		6	6								
32	P446020	Refuerzo inferior fondo cuba		6	6								
33	P446010	Rodamiento 6207-2RSC3		1	2								
34	P516002	Casquillo retenes		1	1								
35	Q261030	Arandela muelle A-5		3	3								
36	Q122032	Tornillo allem M-5x15		3	3								
37	P456004	Junta retenes		1	1								
38	P446003	Anillo posterior soporte cuba		1	1								
39	P516004	Fondo de cuba		1	1								
40	P514922	Reten V-RING 40 A		1	1								
41	P514921	Reten V-RING 50 A		1	1								
42	P446017	Lengüeta de ajuste A8x7x45		1	1								
43	P434916	Tambor LC-7		1	-								
43	P444920	Tambor LC-10		-	1								
44	P506103	Junta de cuba		1	1								
45	Q012056	Tornillo exagonal M-8x40		12	12								
46	Q012056	Tornillo exagonal M-8x40		1	1								
47	Q221309	Tuerca exagonal autoblocante M-8		1	1								
48	P506106	Cuba L-7		1	-								
48	P516105	Cuba L-10		-	1								
49	P520332	Fondo puerta		1	1								
50	Q032031	Tornillo alomado M-5x10		4	4								
51	3673700	Perfil goma gris en "U" 12x6x1350		1	1								
52	Q151341	Tornillo exagonal M-12x35		4	4								
53	Q301313	Arandela plana Ø38xØ12x3		6	6								

N plano C-1157
 Firma 
 Fecha 5-2002
 Aparato LAVADORA LC-14
 PARTE FUNCIONAL MECANICA
 Laminas 3
 Ofite Fagor Industrial S. Coop. 

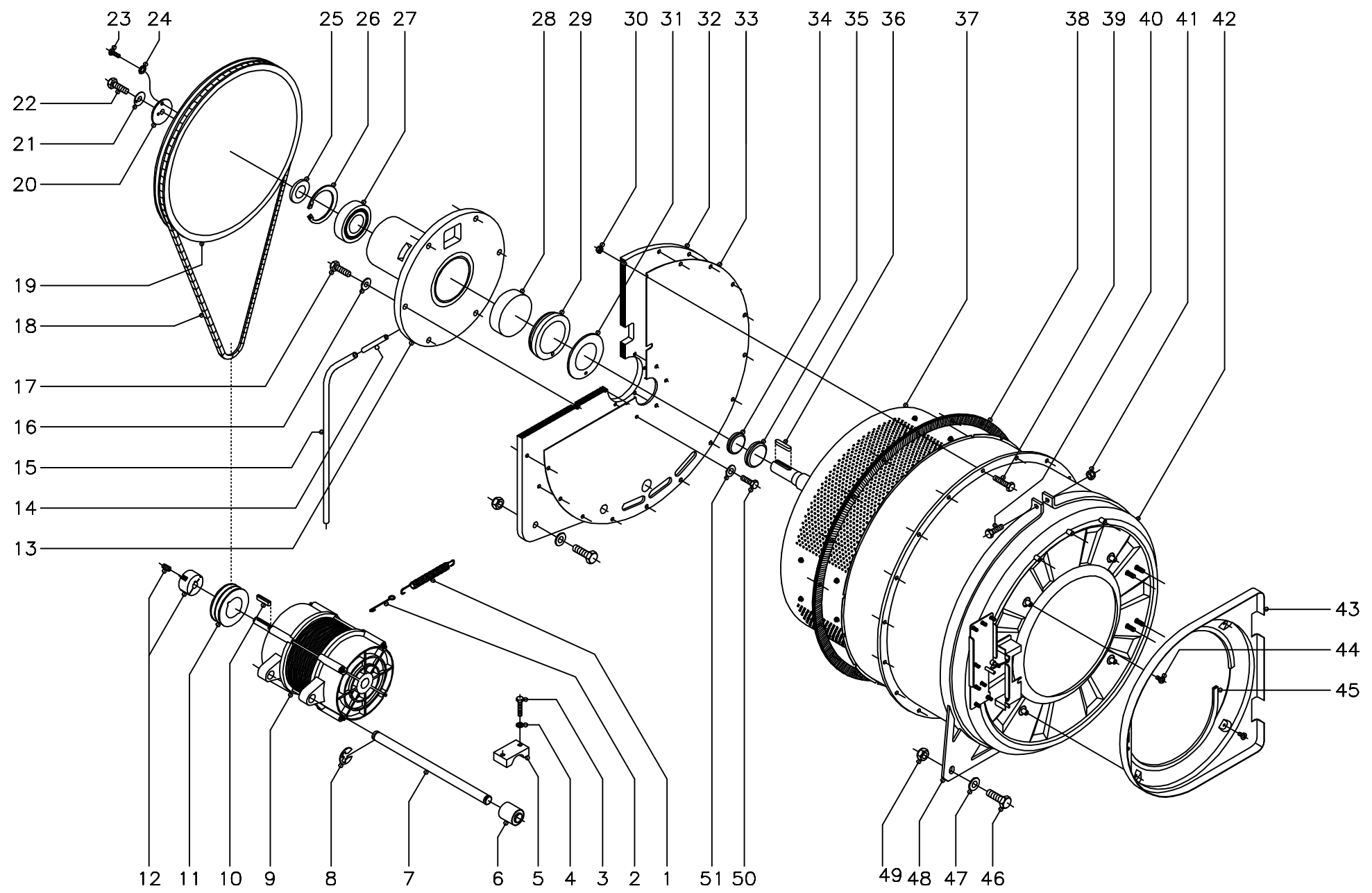

MOD.	LAVADORAS LC	ZONA	PARTE FUNCIONAL MECANICA	PLANO	C-1157
------	--------------	------	--------------------------	-------	--------

ITEM	CODIGO	DENOMINACION	TEXTO	LC-14										NOTAS
1	P445912	Resorte tensor de motor		1										
2	P445915	Alargadera resorte tensor		1										
3	Q012056	Tornillo exagonal M-8x40		4										
4	Q242050	Arandela abanico A-8		4										
5	P535909	Amarre superior amortiguacion		2										
6	P535910	Amortiguador motor		2										
7	P525905	Eje soporte motor		1										
8	Q271027	Arandela de seguridad Ø15		2										
9	P525902	Motor 230/400 V. 50Hz.		1										
10	P446017	Lengüeta de ajuste A8x7x45		1										
11	P435903	Polea motor		1										
12	P455904	Casquillo polea con tornillos		1										
13	P526001	Soporte rodamientos		1										
14	P446019	Tubo Ø10xØ8x100		1										
15	3721900	Tubo transparente Ø12xØ10x400		1										
16	Q301010	Arandela Ø27xØ12,5x2,5		6										
17	Q151341	Tornillo exagonal M-12x35		6										
18	P525906	Correa SPZ. LW-1900		2										
19	P506002	Polea tambor		1										
20	P446016	Arandela fijacion polea		1										
21	Q301329	Arandela de seguridad		1										
22	Q151341	Tornillo exagonal M-12x35		1										
23	Q032041	Tornillo alomado M-6x10		1										
24	Q242040	Arandela abanico A-6		1										
25	P526005	Casquillo		1										
26	Q301030	Anillo de seguridad Ø90		1										
27	P305934	Rodamiento 6308 2Z		1										
28	P305933	Rodamiento 6309 2RS		1										
29	P526013	Casquillo soporte rodamientos		1										

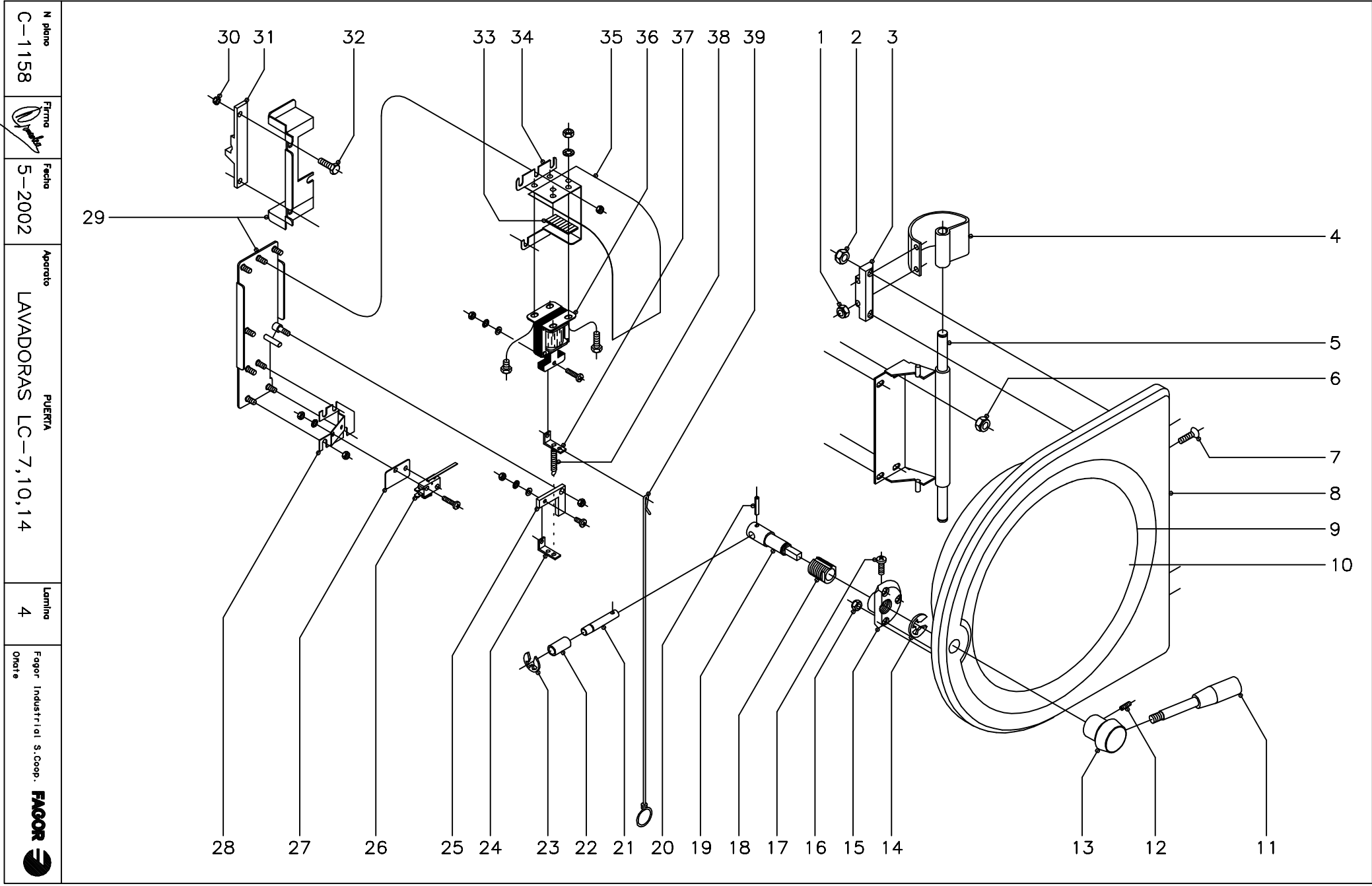

N plano
C-1158

Firma

Fecha
5-2002

Aparato
LAVADORAS LC-7,10,14

Laminas
4

Fagor Industrial S.Coop.
Omate

MOD.	LAVADORAS LC	ZONA	PUERTA	PLANO	C-1158
------	--------------	------	--------	-------	--------

ITEM	CODIGO	DENOMINACION	TEXTO	LC-7	LC-10	LC-14							NOTAS
1	Q222030	Tuerca autoblocante M-5		4	4	4							
2	Q222012	Tuerca autoblocante M-6		4	4	4							
3	P500504	Sujecion bisagra		2	2	2							
4	P500502	Bisagra puerta		2	2	2							
5	P500511	Soporte bisagra		1	1	1							
6	Q222012	Tuerca autoblocante M-6		4	4	4							
7	Q062035	Tornillo allem 3 avellanado M-5x30		4	4	4							
8	P520508	Marco puerta		1	1	1							
9	P440502	Junta de puerta		1	1	1							
10	P440503	Mirilla puerta		1	1	1							
11	P520512	Palanca cierre puerta		1	1	1							
12	Q132042	Varilla roscada M-6x15		1	1	1							
13	P520513	Casquillo palanca cierre puerta		1	1	1							
14	Q271031	Anillo seguridad A-9		1	1	1							
15	P520515	Soporte cojinete guia		1	1	1							
16	Q222012	Tuerca autoblocante M-6		3	3	3							
17	Q152015	Tornillo alomado M-3x6		1	1	1							
18	P520503	Cojinete guia		1	1	1							
19	P520500	Eje palanca cierre		1	1	1							
20	Q371033	Manguito sujecion Ø3x12		1	1	1							
21	P530542	Eje tope		1	1	1							
22	P530544	Casquillo cierre		1	1	1							
23	Q301043	Anillo seguridad A-10		1	1	1							
24	P530559	Empalme muelle		1	1	1							
	Q032011	Tornillo alomado M-3x10		1	1	1							
	Q231310	Arandela plana A-3		1	1	1							
	Q242010	Arandela abanico A-3		1	1	1							
	Q161310	Tuerca exagonal M-3		1	1	1							
25	P530514	Tope cierre		1	1	1							

MOD.		LAVADORAS LC		ZONA	PUERTA						PLANO	C-1158
ITEM	CODIGO	DENOMINACION	TEXTO	LC-7	LC-10	LC-14						NOTAS
	Q222012	Tuerca autoblocante M-6		1	1	1						
26	P530558	Microrruptor puerta		1	1	1						
	Q032013	Tornillo alomado M-3x20		2	2	2						
	Q242010	Arandela abanico A-3		2	2	2						
	Q161310	Tuerca exagonal M-3		2	2	2						
27	R010535	Placa separadora		1	1	1						
28	P530541	Soporte micro		1	1	1						
	Q222012	Tuerca autoblocante M-6		3	3	3						
29	-	Sujeciones del cierre		-	-	-						Soldados a cuba
30	Q222012	Tuerca autoblocante M-6		2	2	2						
31	P530549	Pestillo		1	1	1						
32	Q012042	Tornillo exagonal M-6x15		2	2	2						
33	3714500	Perfil esponjoso adhesivo 20x2x40		1	1	1						Tope electroiman
34	P510506	Sujecion electroiman		1	1	1						
	Q222012	Tuerca autoblocante M-6		4	4	4						
35	P530540	Cubierta electroiman		1	1	1						
36	P533046	Electroiman de puerta		1	1	1						
	Q012021	Tornillo exagonal M-4x10		4	4	4						
	Q242020	Arandela abanico A-4		4	4	4						
	Q162020	Tuerca exagonal M-4		4	4	4						
37	P530559	Empalme muelle		1	1	1						
	Q032011	Tornillo alomado M-3x20		1	1	1						
	Q231310	Arandela plana A-3		1	1	1						
	Q242010	Arandela abanico A-3		1	1	1						
	Q161310	Tuerca exagonal M-3		1	1	1						
38	P530531	Muelle electroiman		1	1	1						
39	P530507	Palanca apertura manual		1	1	1						

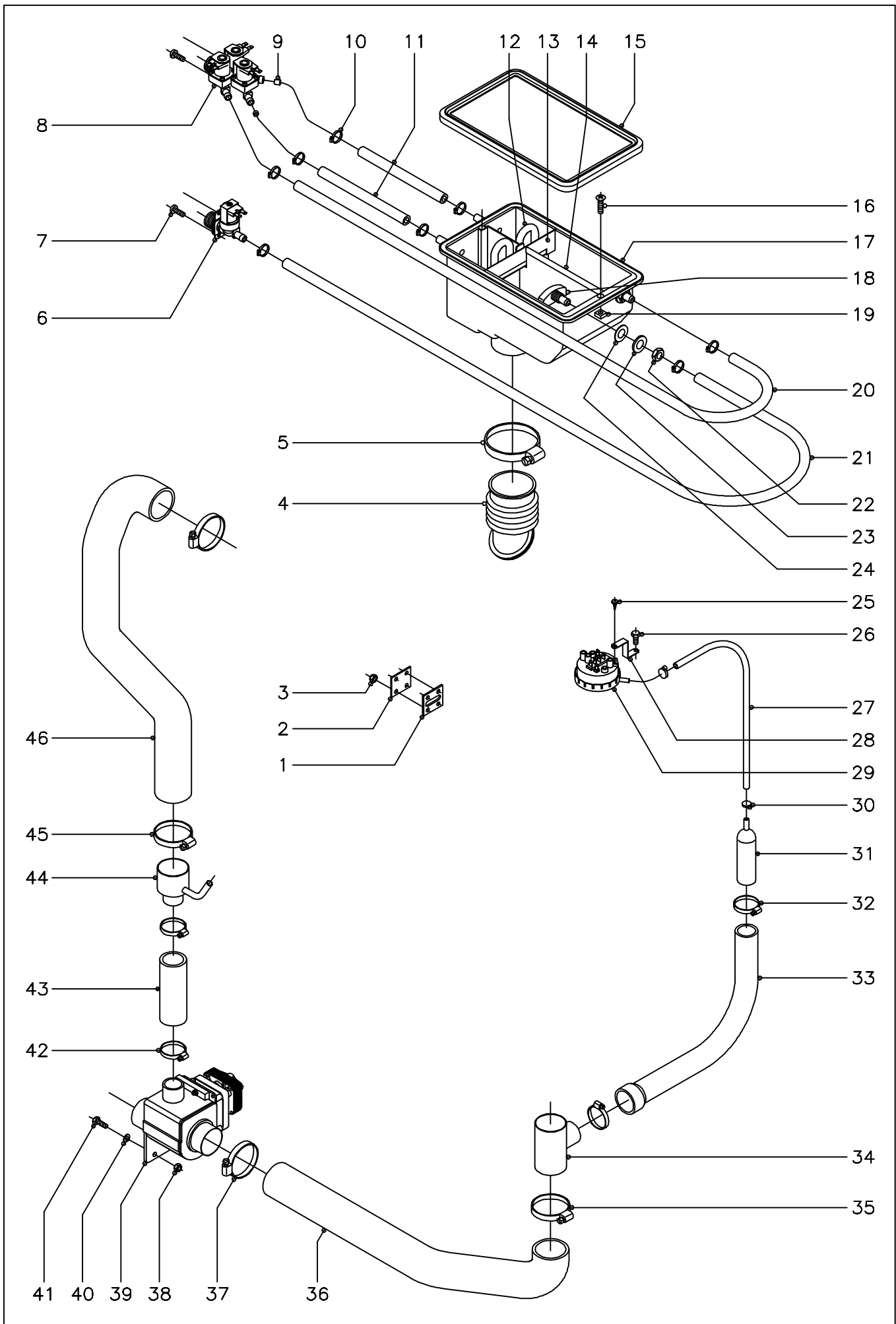



N plano C-1159	Firma 	Fecha 5-2002	Aparato PARTE FUNCIONAL HIDRAULICA LAVADORAS LC-7,10,14	Lamina 5	Fagor Industrial S.Coop. FAGOR
-------------------	-----------	-----------------	---	-------------	---------------------------------------

MOD.	LAVADORAS LC	ZONA	PARTE FUNCIONAL HIDRAULICA	PLANO	C-1159
------	--------------	------	----------------------------	-------	--------

ITEM	CODIGO	DENOMINACION	TEXTO	LC-7	LC-10	LC-14							NOTAS
1	P505003	Junta inyectoros		1	1	1							
2	P435001	Tapa junta		1	1	1							
3	Q222012	Tuerca exagonal autoblocante M-6		4	4	4							
4	P440709	Conducto cubeta a cuba		1	1	1							
5	Q881335	Abrazadera 60 - 80		1	1	1							
6	Z701135	Electrovalvula simple		1	1	1							
7	Q151320	Tornillo alomado M-4x6		4	4	4							
8	Z611123	Electrovalvula triple		1	1	1							
9	P443042	Regulador caudal (3l./m.)		2	2	2							
10	Q881302	Abrazadera 12 - 20		8	8	8							
11	3676900	Tubo de goma Ø17xØ10x550		2	2	2							
12	P440702	Tubo sifon		2	2	2							
13	P440715	Escuadra proteccion		1	1	1							
14	P440721	Perfil refuerzo		1	1	1							
15	P500702	Junta de cubeta		1	1	1							
16	Q152019	Tornillo avellanado M-4x15		2	2	2							
17	P440700	Cubeta de detergentes		1	1	1							
18	P440701	Difusor de detergentes		2	2	2							
19	Q222004	Tuerca cuadrada M-4		2	2	2							
20	3676900	Tubo de goma Ø17xØ10x700		1	-	-							
20	3676900	Tubo de goma Ø17xØ10x850		-	1	-							
20	3676900	Tubo de goma Ø17xØ10x900		-	-	1							
21	3676900	Tubo de goma Ø17xØ10x700		1	-	-							
21	3676900	Tubo de goma Ø17xØ10x850		-	1	-							
21	3676900	Tubo de goma Ø17xØ10x900		-	-	1							
22	Q223018	Tuerca exagonal M-16x1,5		2	2	2							
23	Q301302	Arandela plana A-17		2	2	2							
24	Q307002	Arandela junta		2	2	2							
25	Q082032	Tornillo alomado BZ-3,5x9,5		1	1	1							

MOD.		LAVADORAS LC		ZONA	PARTE FUNCIONAL HIDRAULICA							PLANO	C-1159
ITEM	CODIGO	DENOMINACION	TEXTO	LC-7	LC-10	LC-14							NOTAS
26	Q032031	Tornillo alomado M-5x10		1	1	1							
27	3702400	Tubo goma negra Ø8xØ4x1000		1	1	1							
28	P503068	Soporte presostato		1	1	1							
29	P503008	Presostato de nivel		1	1	-							
29	P523002	Presostato de nivel		-	-	1							
30	Z704061	Brida cremallera		2	2	2							
31	P445002	Camara presostato		1	1	1							
32	Q881306	Abrazadera 32 - 50		2	2	2							
33	P445001	Codo de presostato		1	1	1							
34	-	Toma presion		1	1	1							Soldado a cuba
35	Q881324	Abrazadera 50 - 70		1	1	1							
36	P445003	Conducto desagüe		1	-	-							
36	P455000	Conducto desagüe		-	1	-							
36	P445005	Conducto rebosadero (desagüe)		-	-	1							
37	Q881324	Abrazadera 50 - 70		1	1	1							
38	Q162030	Tuerca exagonal M-5		2	2	2							
39	P302120	Valvula vaciado		1	1	1							
40	Q302022	Arandela plana Ø16xØ6x1,2		2	2	2							
41	Q012032	Tornillo exagonal M-5x15		2	2	2							
42	Q881306	Abrazadera 32 - 50		2	2	2							
43	P502106	Tubo rebosadero		1	1	1							
44	P502101	Reduccion rebosadero		1	1	1							
45	Q881324	Abrazadera 50 - 70		2	2	2							
46	P445005	Conducto rebosadero		1	1	1							

N plano C-1160
 Firma 
 Fecha 5-2002
 Aprobado LAVADORAS LC-7,10,14
 PARTE FUNCIONAL ELECTRICA
 Laminado 6
 Fagor Industrial S.Coop. Onate

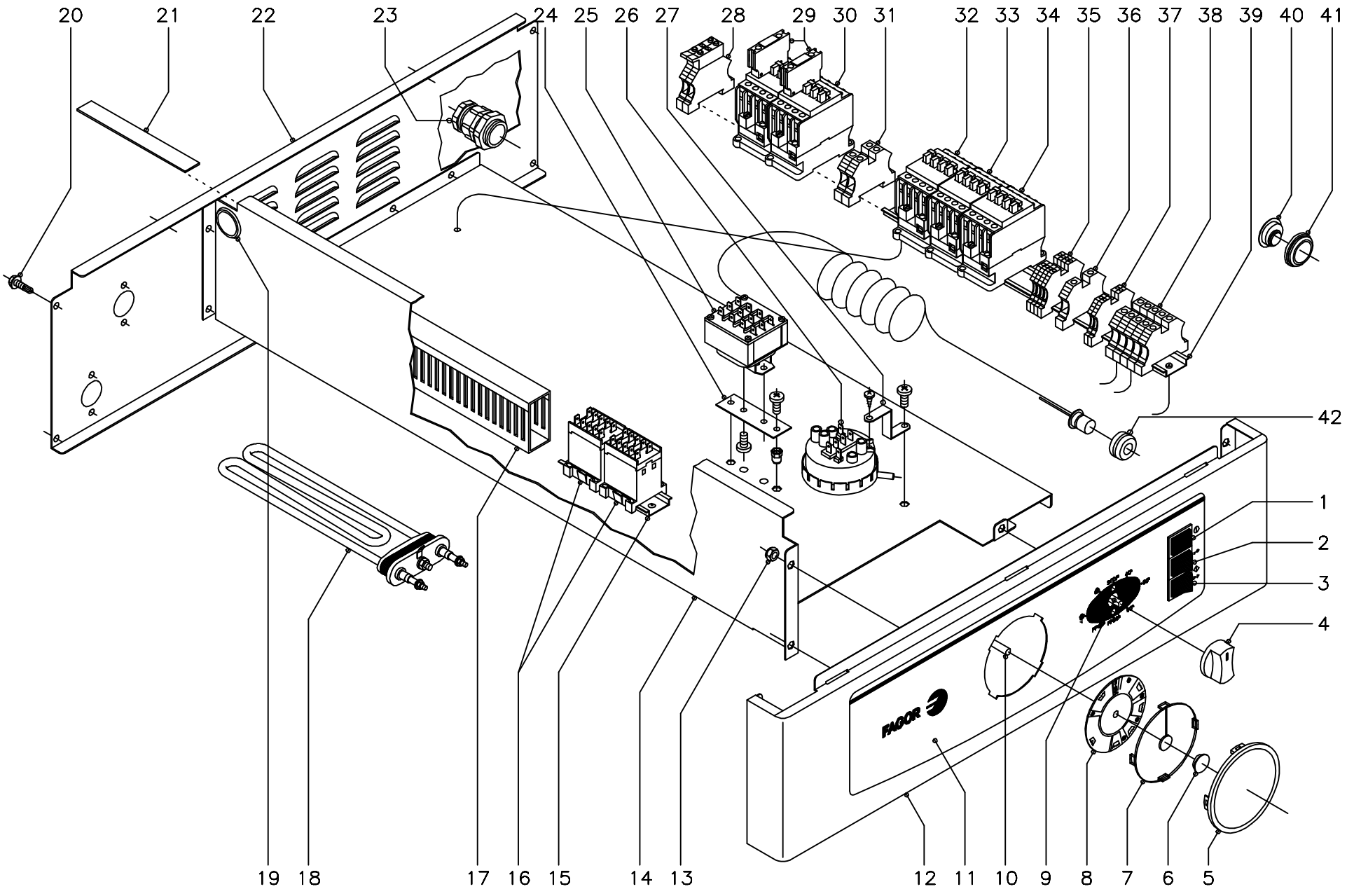



MOD.		LAVADORAS LC		ZONA	PARTE FUNCIONAL ELECTRICA						PLANO	C-1160
ITEM	CODIGO	DENOMINACION	TEXTO	LC-7	LC-10	LC-14						NOTAS
1	P503004	Piloto rojo		1	1	1						
2	P503005	Pulsador verde (puerta)		1	1	1						
3	P503006	Pulsador blanco (avance)		1	1	1						
4	R663062	Boton de mando completo		1	1	1						
5	P440336	Marco mirilla		1	1	1						
6	P302882	Embelledor disco programador		1	1	1						
7	P500315	Mirilla de disco		1	1	1						
8	P500314	Disco programador		1	1	1						
9	P433023	Conmutador 8 posiciones		1	1	1						
	Z602906	Casquillo distanciador		2	2	2						Amarre conmutador
	Q041324	Tornillo avellanado M-4x25		2	2	2						Amarre conmutador
10	P433004	Programador rotativo		1	1	1						
	Q151320	Tornillo alomado M-4x6		2	2	2						Amarre programador
	Q242020	Arandela abanico A-4		2	2	2						Amarre programador
11	P500310	Embelledor portamandos		1	1	1						
12	P500316	Portamandos		1	1	-						
12	P520310	Portamandos		-	-	1						
13	Q222012	Tuerca exagonal autoblocante M-6		3	3	3						
14	P433033	Soporte cuadro electrico LC-7		1	-	-						
14	P443082	Soporte cuadro electrico LC-10		-	1	-						
14	P453033	Soporte cuadro electrico LC-14		-	-	1						
15	Z103084	Guia contactor L=138		1	1	1						
16	Z683087	Contacto 230 V.		2	2	2						
17	3715520	Canaleta unex 60x30xlongitud		6	6	6						
	Q419005	Remache tubular Ø4x8		12	12	12						
18	P103012	Resistencia 2000 W. 230 V.		3	-	-						
18	P143002	Resistencia 3000 W. 230 V.		-	3	-						
18	P183002	Resistencia 4000 W. 230 V.		-	-	3						
19	X723014	Pasamuros Ø30		2	2	2						

MOD.	LAVADORAS LC	ZONA	PARTE FUNCIONAL ELECTRICA	PLANO	C-1160
------	--------------	------	---------------------------	-------	--------

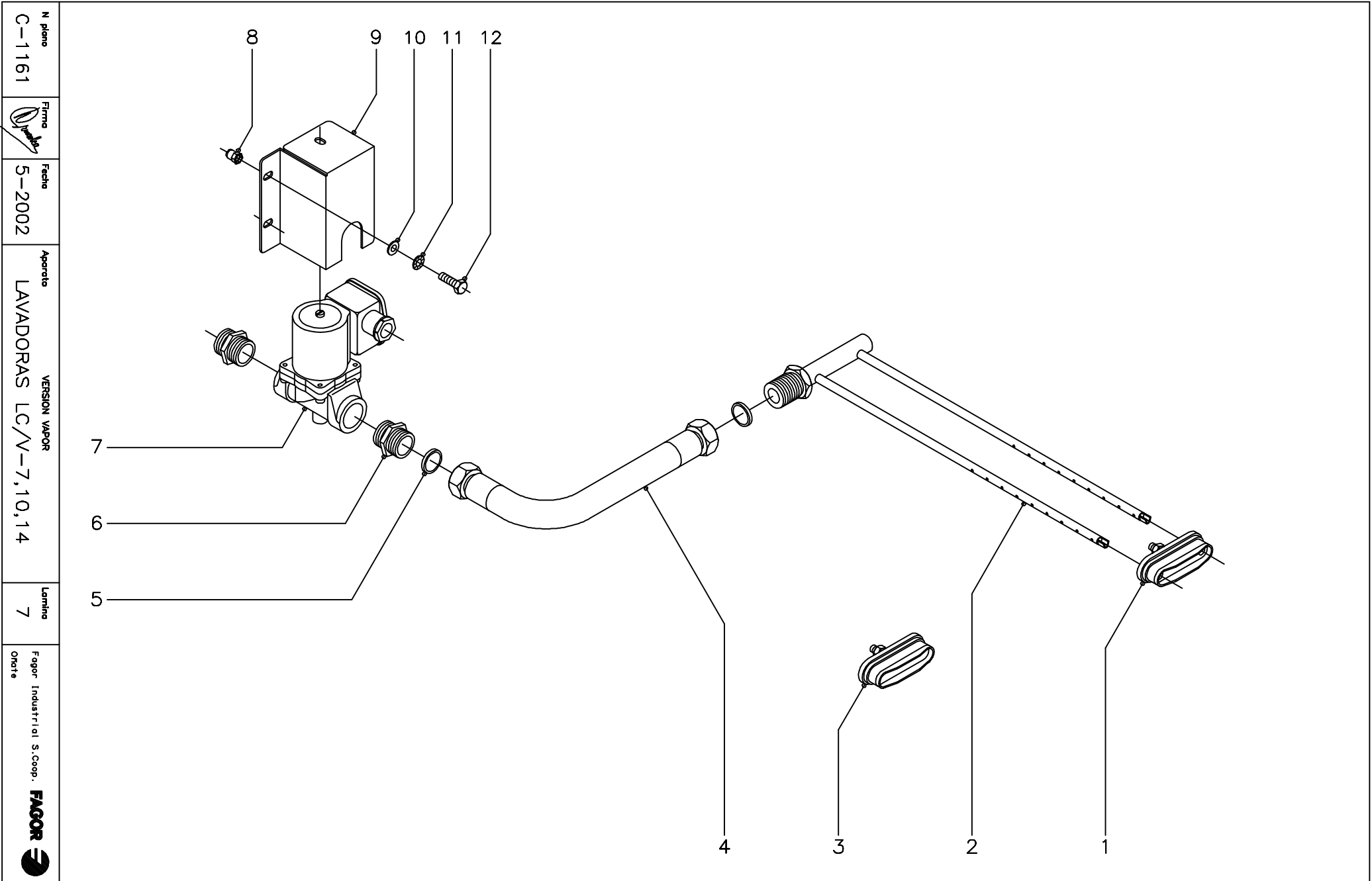
ITEM	CODIGO	DENOMINACION	TEXTO	LC-7	LC-10	LC-14								NOTAS
20	Q151323	Tornillo broca Ø4,8x16		9	9	9								
21	3714500	Perfil esponjoso adhe. 20x2x1000		1	1	1								
22	P500304	Soporte electrovalvulas LC-7 y 10		1	1	-								
22	P520304	Soporte electrovalvulas LC-14		-	-	1								
23	R023013	Prensaestopas		1	1	1								
24	P453020	Sujecion termostato		1	1	1								
	Q032031	Tornillo alomado M-5x10		2	2	2								
	Q221342	Remache exagonal M-5		2	2	2								
25	P433018	Termostato 4 tempera. Preselecci.		1	1	1								
	Q032021	Tornillo alomado M-4x10		2	2	2								
26	P503008	Presostato de nivel		1	1	-								
26	P523002	Presostato de nivel		-	-	1								
	Q082032	Tornillo alomado BZ-3,5x9,5		1	1	1								
27	P503068	Soporte presostato		1	1	1								
	Q032031	Tornillo alomado M-5x10		1	1	1								
28	R073005	Borna portafusibles		2	2	2								
	P184011	Cartucho fusible 4 A.		2	2	2								
29	Z316328	Contacto auxiliar 1NC 3TX4001-2A		2	2	2								
30	P433030	Contactador 3TF3001-OAL2 (230V.)		2	2	2								
31	P453025	Borne paso 10 (gris)		2	2	2								
32	P433030	Contactador 3TF3001-OAL2 (230V.)		1	1	1								
33	P433030	Contactador 3TF3001-OAL2 (230V.)		1	1	1								
34	P433030	Contactador 3TF3001-OAL2 (230V.)		1	1	1								
35	Z103029	Borne paso 2,5 (gris)		4	4	4								
36	P453026	Borne tierra 10 (amarillo-verde)		1	1	1								
37	Z103029	Borne paso 2,5 (gris)		2	2	2								
38	P453025	Borne paso 10 (gris)		3	3	3								
	Z263302	Borne neutro 10 (azul)		1	1	1								
	P453026	Borne tierra 10 (amarillo-verde)		1	1	1								



N plano C-1161	Firma 	Fecha 5-2002	Aparato LAVADORAS LC/V-7,10,14	Laminas 7	Fagor Industrial S. Coop. Onate
-------------------	--	-----------------	-----------------------------------	--------------	------------------------------------

VERSION VAPOR



MOD.		LAVADORAS LC		ZONA	VERSION VAPOR						PLANO	C-1161	
ITEM	CODIGO	DENOMINACION	TEXTO	LC/ E-7	LC/ E-10	LC/ E-14	LC/ V-7	LC/ V-10	LC/ V-14				NOTAS
		SE ELIMINAN											
	P103012	Resistencia 2000 W., 230V.		3	-	-	-	-	-				
	P143002	Resistencia 3000 W., 230V.		-	3	-	-	-	-				
	P183002	Resistencia 4000 W., 230V.		-	-	3	-	-	-				
	P433030	Contactador 3TF3001-OAL2 (230V.)		2	2	2	-	-	-				
	P523007	Cableado resistencias		1	1	1	-	-	-				
	P523009	Cableado regletas a contactores		2	2	2	-	-	-				
		SE INTRODUCEN											
1	P445011	Cierre completo		-	-	-	1	1	1				
2	P525000	Inyector de vapor completo		-	-	-	1	1	1				
3	P505008	Tapon cierre completo		-	-	-	2	2	2				
4	P525005	Latiguillo de vapor		-	-	-	1	1	1				
5	-	Arandela junta (con latiguillo)		-	-	-	2	2	2				
6	Z962205	Manguito doble 1/2"		-	-	-	2	2	2				
7	P525006	Electrovalvula vapor 1/2" (50 Hz.)		-	-	-	1	1	1				
8	Q221342	Remache exagonal M-5		-	-	-	2	2	2				
9	P435002	Soporte electrovalvula vapor		-	-	-	1	1	1				
10	Q302022	Arandela plana Ø16xØ6x1,2		-	-	-	2	2	2				
11	Q242030	Arandela abanico A-5		-	-	-	2	2	2				
12	Q012032	Tornillo exagonal M-5x15		-	-	-	2	2	2				
s/n	P525007	Manguera de vapor L=1500		-	-	-	1	1	1				Maquina a red
s/n	P533054	Cableado electrovalvula vapor		-	-	-	1	1	1				

LC-7, LC-10, LC-14

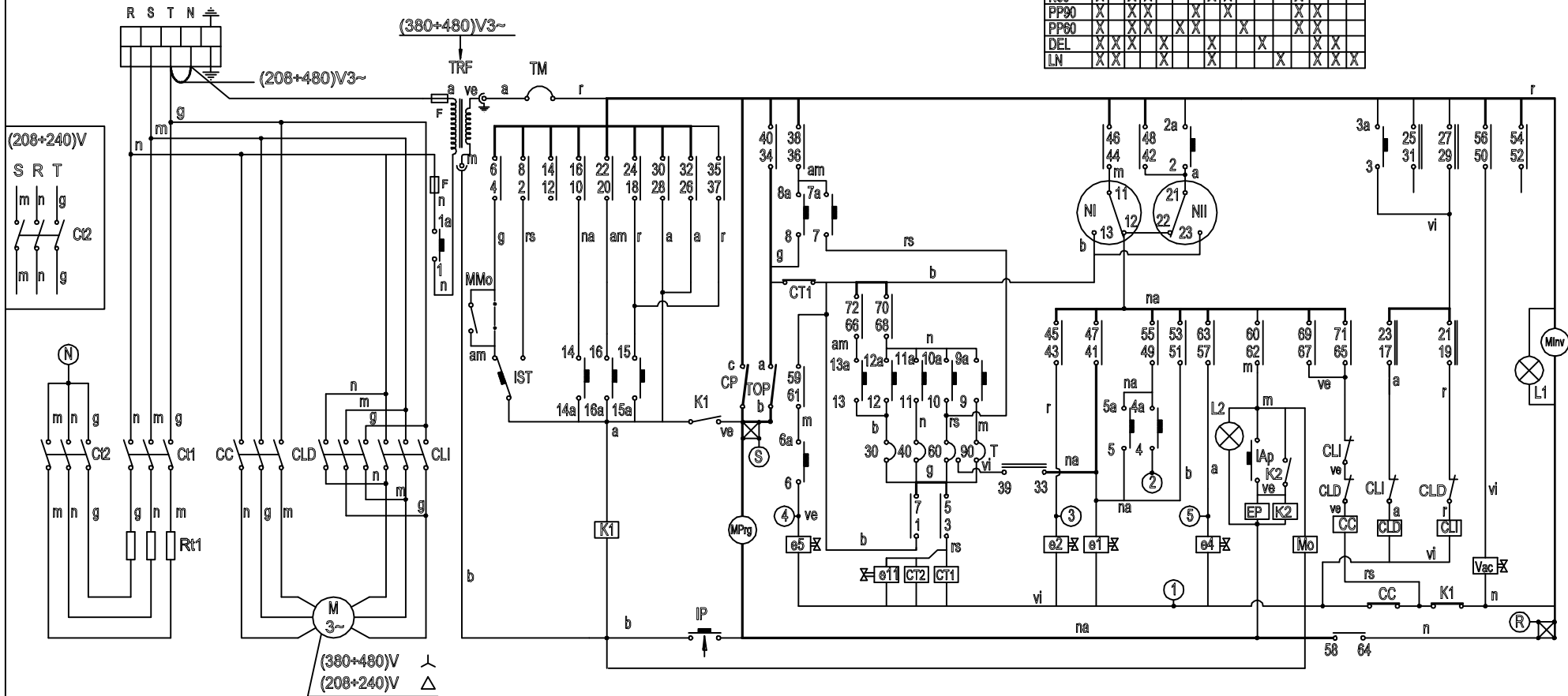

	1	2	3	4	5	6	7	8	9	10	11	12	13	14	15	16
STOP			X	X	X	X	X					X	X			
N40	X	X	X	X	X	X	X				X	X				
N60	X	X	X	X	X	X	X				X	X				
N90	X	X	X	X	X	X	X				X	X				
PP90	X	X	X	X	X	X	X				X	X				
PP90	X	X	X	X	X	X	X				X	X				
DEL	X	X	X	X	X	X	X				X	X				
LN	X	X	X	X	X	X	X				X	X				



Esquema teorico adhesivo 400V 3N (Bajas revoluciones) 7-10-14Kg.			P-453031	
Pieza		N° Clasificación		Acabado
N°	Modificación	Propuesta de	Fecha	Tolerancias generales
1	Introducir conexión transformador	Maillo	12-9-01	< 5± : 50-100± : 5-25± : > 100± : 25-50± : < X±
Dibujado		Firma	Fecha	Mecanizado superficial
Proyectado		S. N.	14-12-00	
Comprobado		 Fagor Industrial, Koop. Elk. Mugstua		
Escala				
LAVADORAS				Plano numero HC-31002 -1
Plano hau ez delako erabili ez beritza gure balmentik gabe				Sustituye al N°
				Sustituido por

ESPAÑOL

CONTACTOS PROGRAMADOR

 Leva principal
 Inversores
 Conmutador

CODIGO DE COLORES:



r = rojo
a = azul
m = marrón
g = gris
n = negro
b = blanco
vi = violeta
am = amarillo
na = naranja
rs = rosa
ve = verde
am/ve = amarillo verde

COMPONENTES:

CC- Contactor Centrifugado (7,10,14,25)
CCL- Contactor Motor (55 Kg)
CL- Contactor Lavado
CLD- Contactor Lavado doha.
CLI- Contactor Lavado Izda.
CT1,CT2- Contactor Calentamiento
CVF- Contactor convertidor
DP- Detector de posición
e1- Electrov. Prelav. y aclarados
e2- Electroválvula Lavado
e3- Electrov. Prelav. y aclar. (25,55)
e4- Electroválvula Suavizante
e5- Electroválvula Lajía
e6,7,8- Electrov. de equilibrio
e9- Electrov. Jabón líquido (electronicas)
e10- Electrov. Jabón líquido (55)
e11- Electrov. Vapor (solo versión)
EP- Electroiman de puerta
F- Fusible
FI- Filtro Interferencias
G1, G2- Sensor galga
IAP- Pulsador Apert. puerta
Iar- Avance rapido
IE- Pula. Parada de emergen. (25,55Kg.)
If- Interruptor de Flot
IG- Interruptor general (selector)
Im- Pulsador Start-Stop
IP- Micro puerta
IS- Interruptor de seguridad
Iso- Interruptor sin centrif.
IST- Puls. Marcha/Avan. rapido
KB- Teclado programador
K1- Rele avance rapido
K2- Rele apertura puerta
L1- Piloto Marcha
L2- Piloto Apertura puerta
L3- Piloto Sin centrifugado
L4- Piloto Flot
M- Motor
MInv- Levas inversión
MMo- Micro monedero
Mo- Monedero
MPrg- Levas principales
NTC - Sensor de temperatura
NI- Presostato Nivel bajo
NIH- Presostato Nivel alto
PI25- Circuito seguridad (25Kg.)
RT1- Resistencia calentamiento
RT2- Resist. calentam. (solo 55)
T- Termostato 30, 40, 60, 90°C
TM- Termico motor
TRF- Transformador (versión 400V.3~)
Vac- Válvula de Vacío
VE- Ventilador de VF (solo 25,55)
VF- Convertidor tensión/frecuencia
VM- Ventilador de Motor (solo 55 Kg)
①...⑨- Puntos de conexión dosificadores

FRANÇAIS

CONTACTS PROGRAMMATEUR

 Came principale
 Renverseurs
 Commutateur

CODES DE COULEURS:



r = rouge
a = bleu
m = marron
g = gris
n = noir
b = blanc
vi = violet
am = jaune
na = orange
rs = rose
ve = vert
am/ve = jaune/vert

COMPOSANTS:

Contacteur centrifugé
Contacteur moteur (55Kg)
Contacteur lavage
Contacteur lavage droit
Contacteur lavage gauche
Contacteur chauffage
Contacteur convertisseur
Déctecteur de position
Electrovalve de prélavage et rinçage
Electrovalve de lavage
(25,55)valve adouceseur
Electrovalve javel
Electrovalve d'équilibrage
Electrovalve lessive liquide (electronique)
Electrovalve lessive liquide (55)
Electrovalve vapeur version seule-ent
Electroaimant de porte
Fusible
Filtre interférences
Senseur bride, jauge
Commande d'ouverture des portes
Avance rapide
Interrupteur arret urgence (25,55Kg.)
Interrupteur de flotteur
Interrupteur général (selector)
Bouton marche arret
Micro porte
Interrupteur de sécurité
Interrupteur sans centrif.
Commande d'avance rapide
Clavier programmeur
Relais avance rapide
Relais ouverture de porte
Pilote de mise en route
Pilote d'ouverture de porte
Pilote sans centrifugage
Pilote de flotteur
Moteur
Cames renversement
Micro monnseyur
Monnseyur
Cames principales
Senseur de température
Pressostat niveau bas
Pressostat niveau haut
Circuit de sécurité (25 Kg.)
Résistance chauffage
Résistance chauffage (seulement 55)
Thermostat 30, 40, 60, 90°C
Moteur thermique
Transformateur (version 400V.3~)
Valve de vidange
Ventilateur de VF (seulement 25,55)
Transformateur de tension/fréquence
Ventilateur de moteur (seulement 55Kg)
Points de branchements de dosificateurs

ENGLISH

PROGRAMMER CONTACTS

 Main levy
 Reverser
 Commutator

COLOUR CODE



r = red
a = blue
m = brown
g = grey
n = black
b = white
vi = violet
am = yellow
na = orange
rs = pink
ve = green
am/ve = yellow-green

COMPONENTS:

Spin relay (7,10,14,25)
Motor relay (55Kg)
Washing relay
Right washing relay
Left washing relay
Heating relay
Inverser relay
Detector of position
Prewashing and dairfied solenoid valve
Washing solenoid valve
Prewashing and dairfied solenoid valve (only 25, 55Kg)
Softener solenoid valve
Bleach solenoid valve
Balanced solenoid valve
Liquid soap solenoid valve (electronic)
Liquid soap solenoid valve (only 55Kg)
Steam solenoid valve (only version)
Door electromagnet
Fuse
Interference filter
Sensor
Door opening switch
Fast advance
Emergency swich (25,55Kg.)
Flot switch
Main swich (selector)
Start-Stop swich
Door swich
Security swich
No spin swich
Star/Fast advance swich
Programmer keyboard
Fast advance relay
Door opening relay
Start lamp
Door opening lamp
No spin lamp
Flot lamp
Motor
Reverser levy
Coin meter swich
Coin meter
Main levy
Temperature sensor
Low level presostat
High level presostat
Security circuit (25Kg.)
Heating element
Heating element (only 55Kg)
Thermostat 30, 40, 60, 90°C
Motor thermal protector
Transformer (400V.3~version)
Drain valve
VF fan (only 25, 55Kg)
Inverser
Motor fan (only 55Kg)
Doser connecting points

DEUTSCH

PROGRAMMIERKONTAKTE

 Hauptnocken
 Umschalter
 Kommutator

FARBENCODE



r = rot
a = blau
m = braun
g = grau
n = schwarz
b = weiss
vi = violett
am = gelb
na = orangens
rs = rosa
ve = grün
am/ve = gelb/grün

KOMPONENTEN:

Schleuderkontakt (7,10,14,25)
Motorkontakt (55Kg)
Waschkontakt
Waschkontakt rechts
Waschkontakt links
Aufheizkontakt
Umfomkontakt
Positionsdetektor
Elektroventil für Vorwaschen und Spülen
Elektroventil für den Waschvorgang
Elektroventil für Vorwaschen und Spülen
Elektroventil für den Weichspülen
Elektroventil für Laugen
Ausgleich-Elektroventil
Elektroventil für Flüssigwaschmittel
Elektroventil für Flüssigwaschmittel
Elektroventil (nur Version)
Tür-Elektromagnet
Sicherung
Interferenzfilter
Galga-Sensor
Tür-Öffnungsknopf
Schnellwaschgang
Notsschalter (25,55Kg.)
Flot-Schalter
Hauptschalter (Selector)
Ein-und Ausschalter
Türbedätigung
Sicherheitsschalter
Schalter-ohne Schleudem
Schalter f.Schnellwaschvorgang
Programmschalter
Relais f.d.Schnellwaschvorgang
Türöffnungsrelais
Startlichtanzeige
Lichtanzeige f.d.Türöffnung
Lichtanzeige-Ohne Schleudem
Flot-Lichtanzeige
Motor
Umkehrnocken
Münzeinwurfeschalter
Münzeinwurf
Hauptnocken
Temperatursensor
Niedrigdruckpresostat
Hochdruckpresostat
Sicherheitschaltung (25Kg.)
Heizsystem
Heizsystemerwärmung (nur 55Kg)
Thermostat, 30,40,60,90°C
Wärmeschutzschaltermotor
Transformator (400V.3~Version)
Ablaufventil
Ventilator (nur 25,55Kg)
Druck-Frequenz umwandler
Motorventilator (nur 55Kg)
Kontaktionspunkte f.Dosierer

ITALIANO

CONTATTI PROGRAMMATORE

 Leva principale
 Invertitori
 Commutatore

CODICE DEI COLORI:

r = rosso
a = azzurro
m = marrone
g = grigio
n = nero
b = bianco
vi = viola
am = giallo
na = arancione
rs = rosa
ve = verde
am/ve = giallo/verde

COMPONENTI:

Contattore centrifuga (7,10,14,25)
Contattore motore (55 Kg)
Contattore lavaggio
Contattore lavaggio destro
Contattore lavaggio sinistro
Contattore riscaldamento
Contattore convertitore
Dettettore di posizione
Electrovalvola prelavaggio e risciaquo
Electrovalvola lavaggio
Electrovalvola prelavaggio e risciaquo (25,55Kg)
Electrovalvola ammorbidente
Electrovalvola candeggina
Electrovalvola di bilanciamento
Electrovalvola detersivo liquido (electronico)
Electrovalvola detersivo liquido (55)
Electrovalvola vapore (solo versione)
Elettrocalamita oblió
F- Fusibile
Filtro interferenze
Sensore callibro
Pulsante apertura porta
Avanzamento rapido
Pulsante arresto d'emergenza (25,55Kg.)
Interruttore del galleggiante
Interruttore generale
Pulsante avvio/stop
Micro porta
Interruttore di sicurezza
Interruttore senza centrifuga
Pulsante funzionamento/avanzamento rapido
Pulsantiera programmi
Relais avanzamento rapido
Relais apertura porta
Spia funzionamento
Spia apertura porta
Spia esclusione centrifuga
Spia galleggiante
Motore
Leve inversione
Micro gettoniera
Gettoniera
Leve principali
Sensore temperatura
Pressostato livello basso
Pressostato livello alto
Circuito di sicurezza (25Kg.)
Resistenza riscaldamento
Resistenza riscaldamento (solo 55Kg)
Termostato 30, 40, 60, 90°C
Interruttore termico motore
Transformatore (versione 400V.3~)
Valvola di Svuotamento
Ventilatore di VF (solo 25,55)
Convertitore tensione/frequenza
Ventilatore del motore (solo 55 Kg)
Punti di connessione dosificatori