

**Lavadoras de centrifugado estándar  
Laveuses à essorage standard  
Washing machines  
Washmaschinen  
Lavatrici**

**LAVANDERIA**

**Modelos:**

**LC/E-25 // LC/AC-25 // LC/V-25**

*Mayo 2002 May*

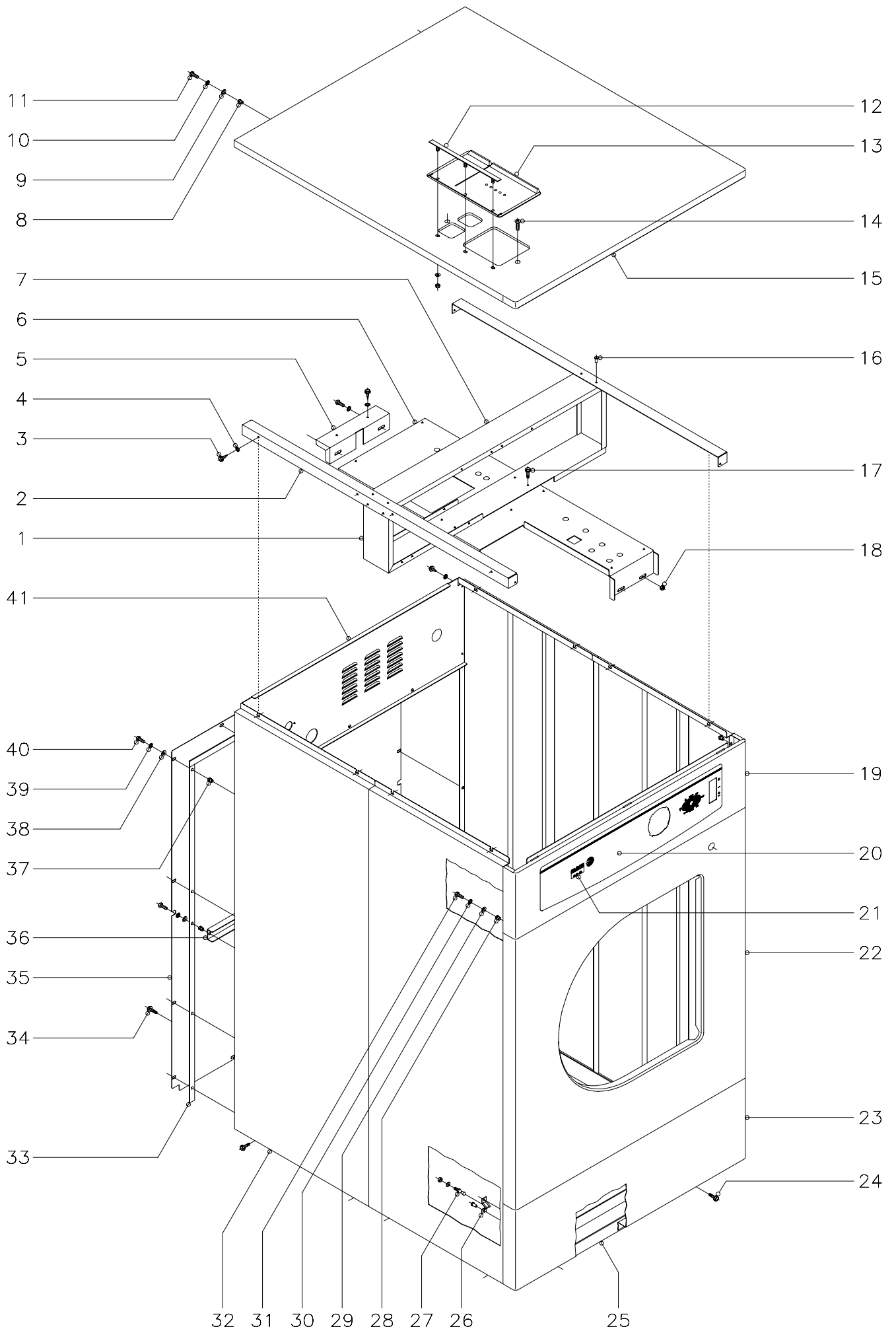

N plano C-1162	Firma <i>[Signature]</i>	Fecha 5-2002	Aparato ARMAZON Y MUEBLE LAVADORAS LC-25	Lamina 1	Fagor Industrial S.Coop. <b>FAGOR</b> Onate
-------------------	-----------------------------	-----------------	--	-------------	--

MOD.		LAVADORAS LC			ZONA	ARMAZON Y MUEBLE						PLANO	C-1162
ITEM	CODIGO	DENOMINACION	TEXTO	LC-25									NOTAS
1	P460301	Sujecion cuadro electrico		1									
2	P530319	Sujecion panel lateral		2									
3	Q151335	Tornillo c/arandela A-5,6x13		10									
4	Q242040	Arandela abanico A-6		10									
5	P533005	Soporte base cuadros		1									
	Q012031	Tornillo exagonal M-5x10		2									Amarre soporte a soporte fondo cuba
	Q242030	Arandela abanico A-5		2									Amarre soporte a soporte fondo cuba
	Q151335	Tornillo c/arandela A-5,6x13		2									Amarre base cuadro a soporte
	Q242040	Arandela abanico A-6		2									Amarre base cuadro a soporte
6	P533004	Base de cuadro electrico		1									
7	P530312	Liston superior		1									
8	Q221342	Remache exagonal M-5		2									
9	Q302022	Arandela plana Ø16xØ6x1,2		2									
10	Q242030	Arandela abanico A-5		2									
11	Q012031	Tornillo exagonal M-5x10		2									
12	P440705	Soporte tapa cubeta		1									
	Q232030	Arandela plana A-5		3									
	Q162030	Tuerca exagonal M-5		3									
13	P440704	Tapa cubeta		1									
14	Q042022	Tornillo avellanado M-5x15		2									
15	P530318	Encimera		1									
16	Q419005	Remache tubular Ø4x8		12									
17	Q151323	Tornillo broca Ø4,8x16		4									
18	Q222012	Tuerca exagonal autoblocante M-6		2									
19	P530303	Portamandos		1									
20	P530304	Embellecedor portamandos		1									
21	P466501	Adhesivo modelo LC/E-25		1									
21	P466502	Adhesivo modelo LC/AC-25		1									
21	P466503	Adhesivo modelo LC/ V-25		1									

MOD.		LAVADORAS LC			ZONA	ARMAZON Y MUEBLE						PLANO	C-1162
ITEM	CODIGO	DENOMINACION	TEXTO	LC-25									NOTAS
21	P466504	Adhesivo modelo LC/E-25, 60 Hz.		1									
21	P466505	Adhesivo mod. LC/E-25,60 Hz.S./N.		1									
21	P466506	Adhesivo modelo LC/E-25, S.N.		1									
22	P530325	Panel frontal		1									
23	P530310	Suplemento panel frontal		1									
24	Q151323	Tornillo broca Ø4,8x16		10									Amarre inferior paneles
25	P530101	Armazon completo		1									
26	X010503	Muelle enganche piton		2									
	Q419007	Remache tubular Ø3,2x6		4									
27	P450303	Piton enganche		2									
	Q232030	Arandela plana A-5		2									
	Q221308	Tuerca exagonal autoblocante M-5		2									
28	Q221342	Remache exagonal M-5		8									
29	Q302022	Arandela plana Ø16xØ6x1,2		8									
30	Q242030	Arandela abanico A-5		8									
31	Q012031	Tornillo exagonal M-5x10		8									
32	P530329	Panel lateral completo		4									
33	3714500	Perfil esponj. adhesivo 20x2x5000		1									
34	Q151323	Tornillo broca Ø4,8x16		2									
35	P530316	Panel posterior		1									
36	P530333	Sujecion panel posterior		1									
37	Q221342	Remache exagonal M-5		15									
38	Q302022	Arandela plana Ø16xØ6x1,2		15									
39	Q242030	Arandela abanico A-5		15									
40	Q012031	Tornillo exagonal M-5x10		15									
41	P530315	Soporte electrovalvulas		1									
	Q242040	Arandela abanico A-6		14									
	Q151335	Tornillo c/arandela A-5,6x13		14									

N plano  
C-1163

Firma  



Fecha  
5-2002

Aparato

PARTE FUNCIONAL MECANICA  
LAVADORAS LC-25

Laminio  
2

Orate

Fagor Industrial S. Coop.  
**FAGOR**  

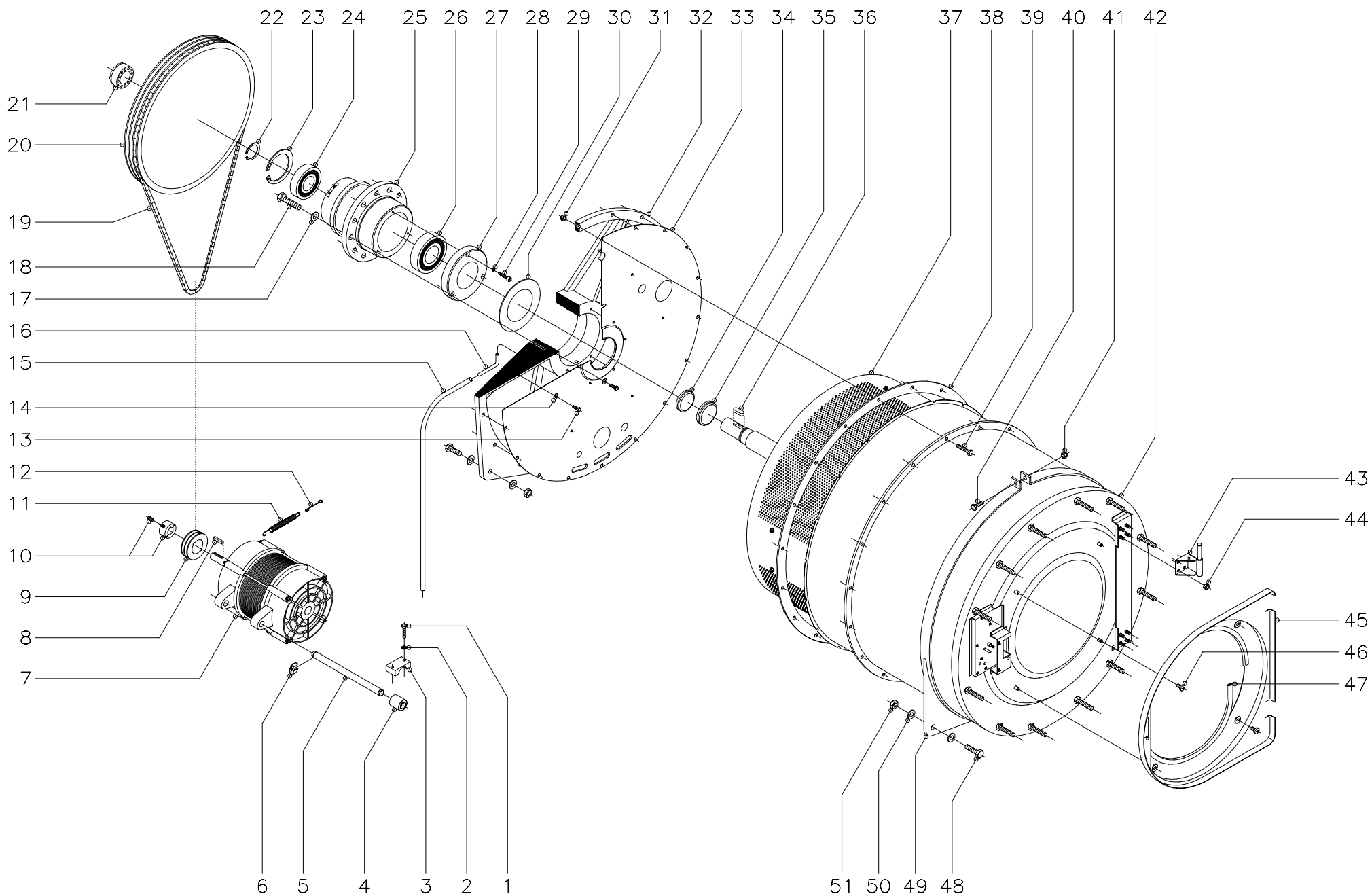

MOD.		LAVADORAS LC			ZONA	PARTE FUNCIONAL MECANICA							PLANO	C-1163
ITEM	CODIGO	DENOMINACION	TEXTO	LC-25									NOTAS	
1	Q012056	Tornillo exagonal M-8x40		4										
2	Q242050	Arandela abanico A-8		4										
3	P535909	Amarre superior amortiguacion		2										
4	P535910	Amortiguador motor		2										
5	P535901	Eje soporte motor		1										
6	Q271027	Arandela de seguridad Ø 15		2										
7	P535904	Motor 230/400 V. 50 Hz.		1										
8	P535912	Lengüeta motor 8x7x40		1										
9	P435903	Polea motor 50 Hz.		1										
10	P455904	Casquillo polea con tornillos		1										
11	P445912	Resorte tensor de motor		2										
12	P445915	Alargadera resorte tensor		2										
13	Q012042	Tornillo exagonal M-6x15		12										
14	Q304040	Arandela estanquei. Ø10,4xØ6,4x1		12										
15	3721900	Tubo transparente Ø14xØ10x800		1										
16	P536016	Tubo evacuacion		1										
17	Q301302	Arandela plana A-17		6										
18	Q011399	Tornillo exagonal M-16x70		6										
19	P535903	Correa SPZ LW 2360		2										
20	P536003	Polea tambor		1										
21	P536017	Buje amarre polea tambor		1										
22	Q301041	Anillo de seguridad en eje Ø50		1										
23	Q301036	Anillo de seguridad J-110x4		1										
24	P536005	Rodamiento 6310-2Z		1										
25	P536002	Soporte rodamientos		1										
26	P536004	Rodamiento 6312-2RS		1										
27	P536008	Contrareten		1										
28	Q262040	Arandela grower A-6		3										
29	Q052046	Tornillo allem M-6x40		3										



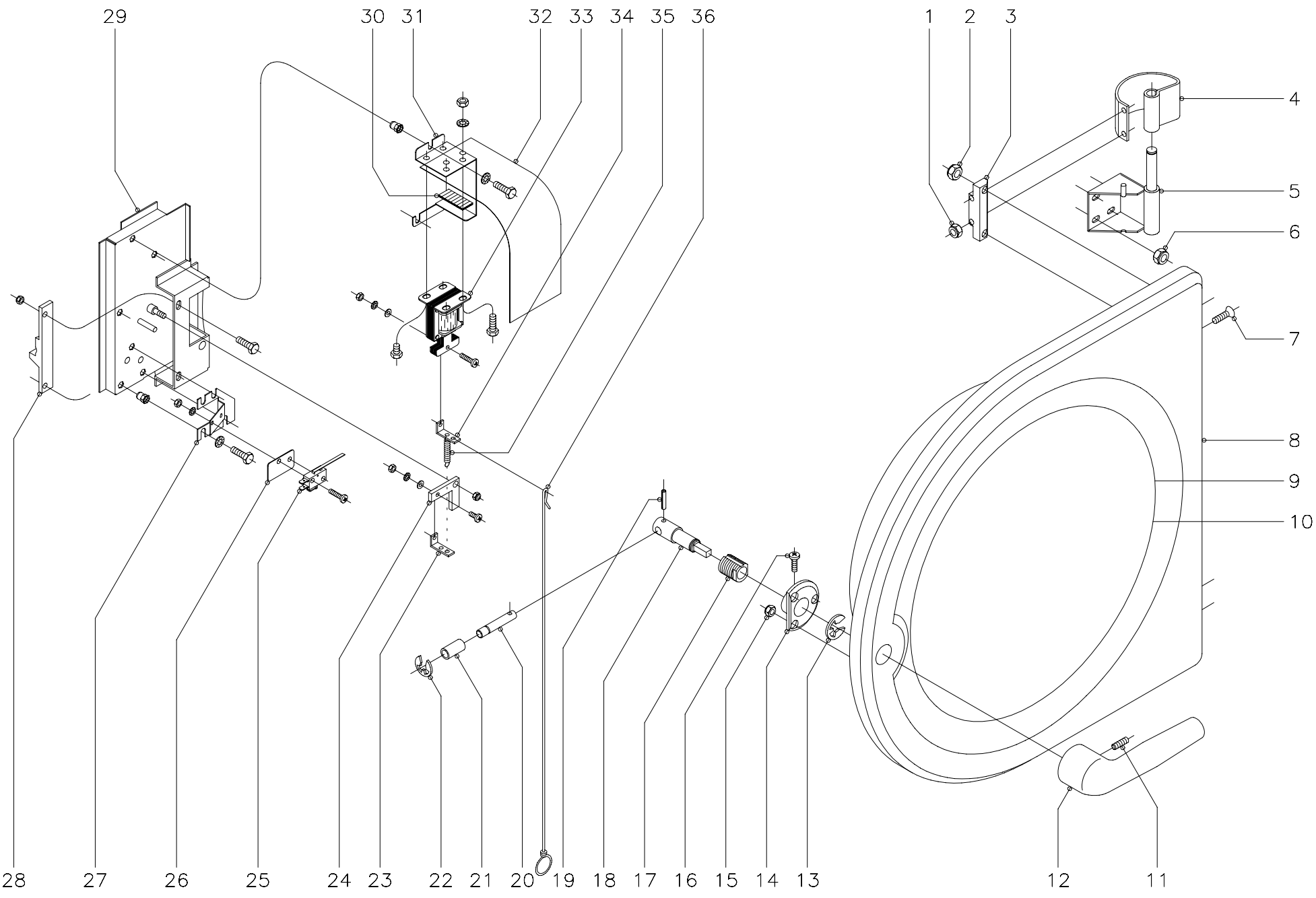

N plano  
C-1164

Firma  
*[Signature]*

Fecha  
5-2002

Aparato

PUERTA  
LAVADORAS LC-25

Lamina  
3

Fagor Industrial S. Coop.  
Onate





MOD.		LAVADORAS LC			ZONA	PUERTA						PLANO	C-1164
ITEM	CODIGO	DENOMINACION	TEXTO	LC-25									NOTAS
1	Q222030	Tuerca autoblocante M-5		4									
2	Q222012	Tuerca autoblocante M-6		4									
3	P500504	Sujecion bisagra		2									
4	P500502	Bisagra puerta		2									
5	P530505	Soporte bisagra		2									
6	Q222012	Tuerca autoblocante M-6		8									
7	Q062035	Tornillo allem 3 avellanado M-5x30		4									
8	P530550	Marco puerta		1									
9	P530502	Junta de puerta		1									
10	P530503	Mirilla puerta		1									
11	Q132042	Varilla roscada M-6x15		1									
12	P530538	Manilla puerta		1									
13	Q271034	Anillo seguridad A-12		1									
14	P530557	Soporte cojinete		1									
15	Q222012	Tuerca autoblocante M-6		3									
16	Q152015	Tornillo alomado M-3x6		1									
17	P530545	Cojinete guia		1									
18	P530543	Eje manilla		1									
19	Q371031	Manguito sujecion Ø3x20		1									
20	P530542	Eje tope		1									
21	P530544	Casquillo cierre		1									
22	Q301043	Anillo seguridad A-10		1									
23	P530559	Empalme muelle		1									
	Q032011	Tornillo alomado M-3x10		1									
	Q231310	Arandela plana A-3		1									
	Q242010	Arandela abanico A-3		1									
	Q161310	Tuerca exagonal M-3		1									
24	P530514	Tope cierre		1									
	Q222012	Tuerca autoblocante M-6		1									

MOD.		LAVADORAS LC			ZONA	PUERTA						PLANO	C-1164
ITEM	CODIGO	DENOMINACION	TEXTO	LC-25									NOTAS
25	P530558	Microrruptor puerta		1									
	Q032013	Tornillo alomado M-3x20		2									
	Q242010	Arandela abanico A-3		2									
	Q161310	Tuerca exagonal M-3		2									
26	R010535	Placa separadora		1									
27	P530541	Soporte micro		1									
	Q012033	Tornillo exagonal M-5x20		3									
	Q242030	Arandela abanico A-5		3									
28	P530549	Pestillo		1									
	Q012042	Tornillo exagonal M-6x15		2									
	Q222012	Tuerca autoblocante M-6		2									
29	-	Sujecion cierre (Soldado a cuba)		-									
30	3714500	Perfil esponjoso adhesivo 20x2x40		1									Tope electroiman
31	P530525	Sujecion electroiman		1									
	Q012033	Tornillo exagonal M-5x20		3									
	Q242030	Arandela abanico A-5		3									
32	P530540	Cubierta electroiman		1									
33	P533046	Electroiman de puerta		1									
	Q012021	Tornillo exagonal M-4x10		4									
	Q242020	Arandela abanico A-4		4									
	Q162020	Tuerca exagonal M-4		4									
34	P530559	Empalme muelle		1									
	Q032011	Tornillo alomado M-3x20		1									
	Q231310	Arandela plana A-3		1									
	Q242010	Arandela abanico A-3		1									
	Q161310	Tuerca exagonal M-3		1									
35	P530531	Muelle electroiman		1									
36	P530507	Palanca apertura manual		1									

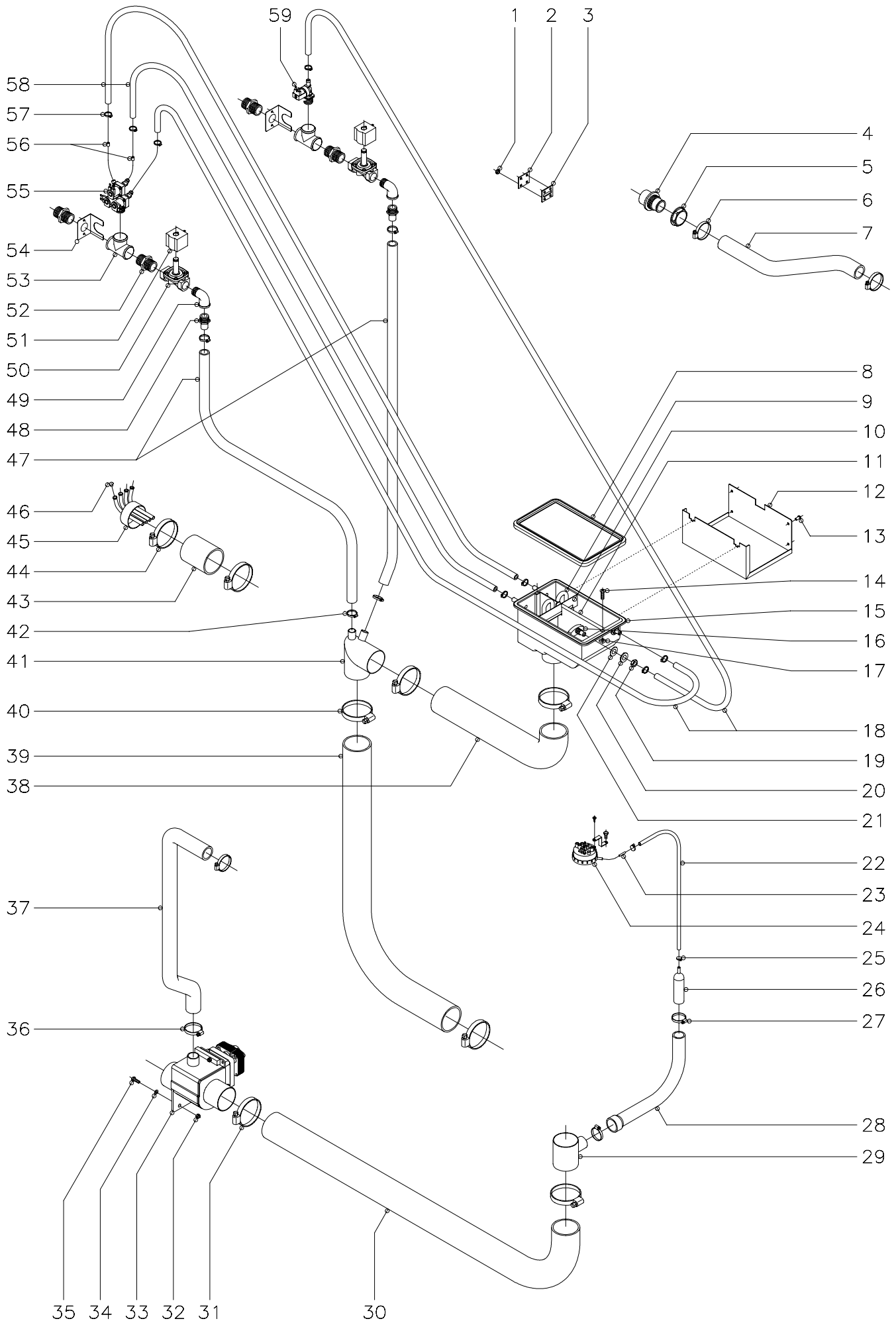

N plano C-1165	Firma <i>[Signature]</i>	Fecha 5-2002	Aparato PARTE FUNCIONAL HIDRAULICA LAVADORAS LC-25	Lamina 4	Fagor Industrial S.Coop. <b>FAGOR</b> Onate
-------------------	-----------------------------	-----------------	--	-------------	--

MOD.		LAVADORAS LC		ZONA	PARTE FUNCIONAL HIDRAULICA							PLANO	C-1165
ITEM	CODIGO	DENOMINACION	TEXTO	LC-25									NOTAS
1	Q222012	Tuerca exagonal autoblocante M-6		4									
2	P435001	Tapa junta		1									
3	P505003	Junta inyector		1									
4	Z740701	Pasamuros		1									
5	Z710708	Tuerca pasamuros		1									
6	Q881306	Abrazadera 32-50		2									
7	P532102	Conducto salida vapores		1									
8	P500702	Junta de cubeta		1									
9	P440702	Tubo sifon		2									
10	P440715	Escuadra proteccion		1									
11	P440721	Perfil refuerzo		1									
12	P460701	Sujecion cubetera		1									
13	Q419000	Remache tubular Ø4x8		4									
14	Q042022	Tornillo avellanado M-4x15		2									
15	P440700	Cubeta de detergentes		1									
16	P440701	Difusor de detergentes		2									
17	Q222004	Tuerca cuadrada M-4		2									
18	3676900	Tubo goma negra Ø17xØ10x1300		2									
19	Q223018	Tuerca exagonal M-16x1,5		2									
20	Q301302	Arandela plana A-17		2									
21	Q307002	Arandela junta Ø28xØ15x1		2									
22	3702400	Tubo goma negra Ø8xØ4x2000		1									
23	P533034	Amortiguador presostato		1									
24	P533002	Presostato de nivel		1									
	Q082032	Tornillo alomado BZ-3,5x9,5		1									
	P503068	Soporte presostato		1									
	Q032031	Tornillo alomado M-5x10		1									
25	Z704061	Brida cremallera		2									
26	P445002	Camara presostato		1									

MOD.		LAVADORAS LC			ZONA	PARTE FUNCIONAL HIDRAULICA							PLANO	C-1165
ITEM	CODIGO	DENOMINACION	TEXTO	LC-25									NOTAS	
27	Q881306	Abrazadera 32-50		2										
28	P445001	Codo de presostato		1										
29	-	Toma presion		1									Soldado a cuba	
30	P532101	Conducto a valvula vaciado		1										
31	Q881326	Abrazadera 70-90		2										
32	Q162030	Tuerca exagonal M-5		2										
33	P532103	Valvula de vaciado		1										
34	Q242040	Arandela abanico A-6		2										
35	Q012032	Tornillo exagonal M-5x15		2										
36	Q881306	Abrazadera 32-50		2										
37	P532102	Conducto rebosadero		1										
38	P540701	Conducto cubeta a codo		1										
39	P532109	Conducto de llenado codo a cuba		1										
40	Q881326	Abrazadera 70-90		4										
41	P530799	Codo entrada agua		1										
42	Q881304	Abrazadera 20-32		4										
43	P532108	Tubo tapon empalme dosificadores		1										
44	Q881326	Abrazadera 70-90		2										
45	P532111	Empalme dosificadores		1										
46	P532116	Tapon empalme dosificadores		4										
47	3714800	Tubo goma negra Ø26xØ19x200		2										
48	P533009	Empalme 3/4"		2										
49	Z718421	Codo M-H 3/4"		2										
50	Z102305	Electrovalvula 3/4"		2										
51	Z102323	Bobina de electrovalvula 240 V.		2										
52	Z102301	Manguito 3/4"		4										
53	Z102303	Te a 90° de 3/4"		2										
54	P535003	Tope electrovalvula		2										
55	Z611123	Electrovalvula triple		1										



N plano  
C-1166

Firma  
*Fagor*

Fecha  
5-2002

Apartido  
PARTE FUNCIONAL ELECTRICA  
LAVADORAS LC-25

Lamina  
5

Oforte  
Fagor Industrial S.Coop. **FAGOR**

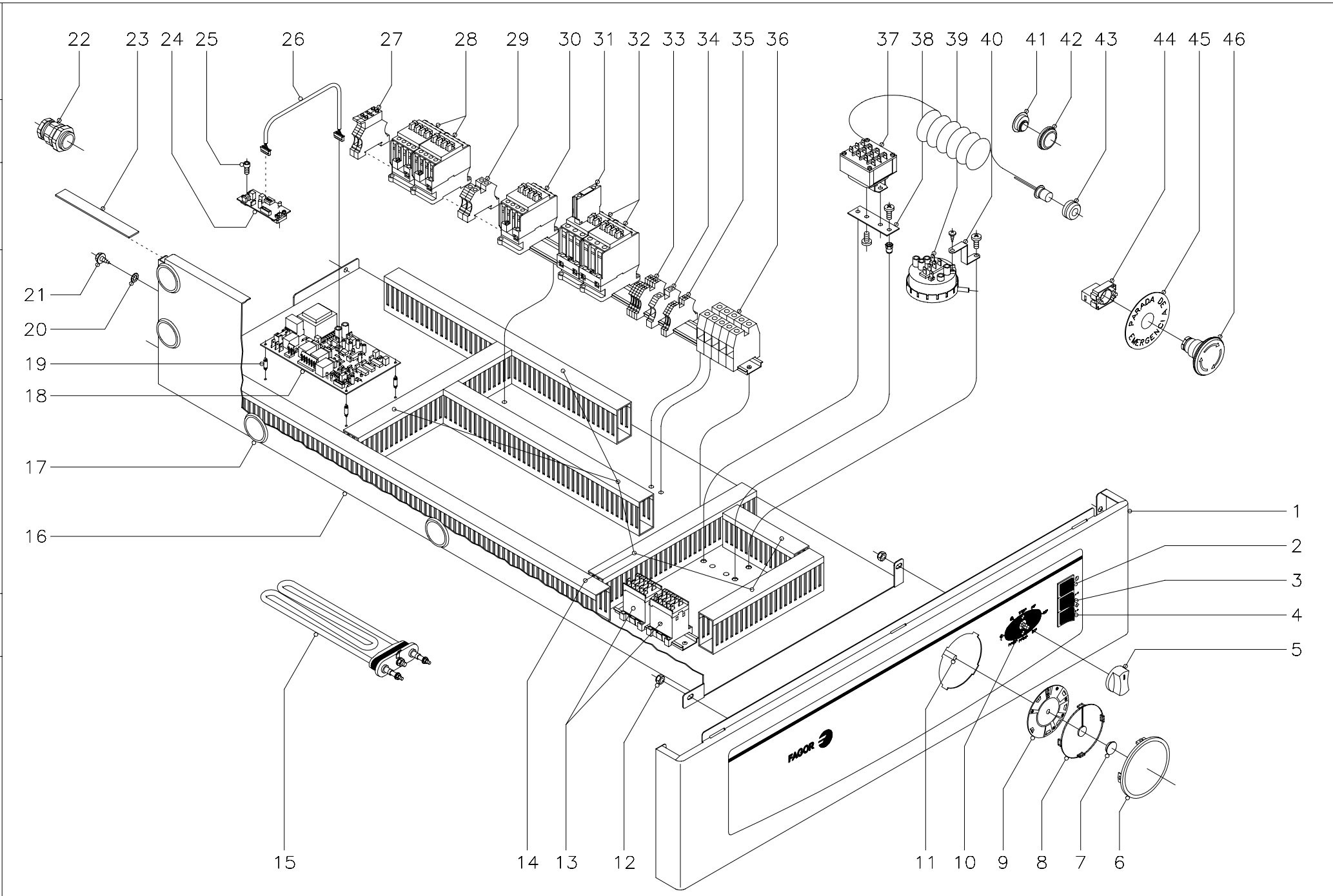

MOD.		LAVADORAS LC		ZONA	PARTE FUNCIONAL ELECTRICA							PLANO	C-1166
ITEM	CODIGO	DENOMINACION	TEXTO	LC-25								NOTAS	
1	P530303	Portamandos		1									
2	P503004	Piloto rojo		1									
3	P503005	Pulsador verde (puerta)		1									
4	P503006	Pulsador blanco (avance)		1									
5	R663062	Boton de mando completo		1									
6	P440336	Marco mirilla		1									
7	P302882	Embellecedor disco programador		1									
8	P500315	Mirilla de disco		1									
9	P500314	Disco programador		1									
10	P433023	Conmutador 8 posiciones		1									
	Z602906	Casquillo distanciador		2								Amarre conmutador	
	Q041324	Tornillo avellanado M-4x25		2								Amarre conmutador	
11	P433004	Programador rotativo		1									
	Q151320	Tornillo alomado M-4x6		2								Amarre programador	
	Q242020	Arandela abanico A-4		2								Amarre programador	
12	Q222012	Tuerca exagonal autoblocante M-6		3									
13	Z683087	Contactador 230 V.		2									
	Z103084	Guia contactor L=138		1									
14	3715520	Canaleta unex 60x30xlongitud		7									
	Q419005	Remache tubular Ø4x8		20									
15	P533001	Resistencia 6000 W. 230 V.		3									
16	P463006	Cuadro electrico		1									
17	X723014	Pasamuros Ø30		4									
18	P463001	Circuito seguridad bajas revolucio.		1									
19	P503043	Separador		4									
20	Q242040	Arandela abanico A-6		4									
21	Q151335	Tornillo c/arandela A-5,6x13		4									
22	R033002	Prensaestopas		1									
23	3714500	Perfil esponjoso adhe.20x2x1000		1									



MOD.		LAVADORAS LC			ZONA	PARTE FUNCIONAL ELECTRICA						PLANO	C-1166
ITEM	CODIGO	DENOMINACION	TEXTO	LC-25									NOTAS
24	P533016	Sensor galga liar		1									
25	Q122032	Tornillo allem M-5x15		2									
26	P503028	Cableado sensor		1									
27	R073005	Borna portafusibles		2									
	P184011	Cartucho fusible 4 A.		2									
28	P433030	Contactador 3TF3001-OAL2 (230V.)		2									
29	P453025	Borne paso 10 (gris)		2									
30	P433030	Contactador 3TF3001-OAL2 (230V.)		1									
31	P443080	Contacto auxiliar 3RH1921-1CAO1		1									
32	X183011	Contactador 3RT1024-1AN20 (230V.)		2									
33	Z103029	Borne paso 2,5 (gris)		4									
34	P453026	Borne tierra 10 (amarillo-verde)		1									
35	Z103029	Borne paso 2,5 (gris)		2									
36	R263003	Borne paso 35 (gris)		3									
	R673010	Borne neutro 35 (azul)		1									
	Z103035	Borne tierra 35 (amarillo-verde)		1									
	Z103083	Guia contactor L= 73		1									
	R663054	Guia contactor L= 320		1									
37	P433018	Termostato 4 tempera. Preselecci.		1									
	Q032021	Tornillo alomado M-4x10		2									
38	P453020	Sujecion termostato		1									
	Q032031	Tornillo alomado M-5x10		2									
	Q221342	Remache exagonal M-5		2									
39	P533002	Presostato de nivel		1									
	Q082032	Tornillo alomado BZ-3,5x9,5		1									
40	P503068	Soporte presostato		1									
	Q032031	Tornillo alomado M-5x10		1									
41	P443060	Tapon		1									
42	N503017	Soporte termostato		1									





N plano  
C-1167

Firma  



Fecha  
5-2002

Aparato  
LAVADORAS LC/V-25

VERSION VAPOR

Lamina  
6

Fagor Industrial S.Coop.  
Onate

**FAGOR**  

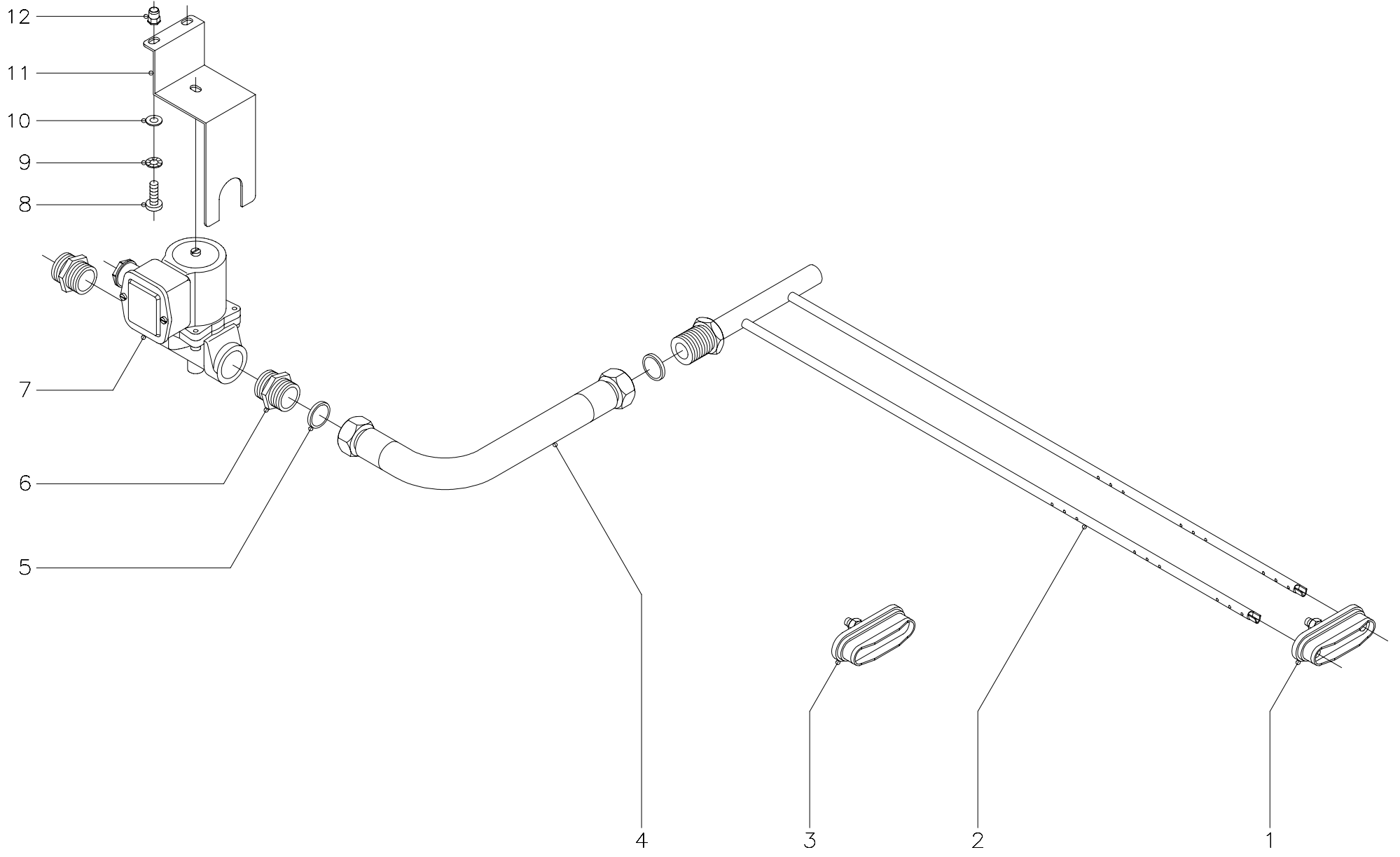

MOD.		LAVADORAS LC			ZONA	VERSION VAPOR						PLANO	C-1167
ITEM	CODIGO	DENOMINACION	TEXTO	LC/ E-25	LC/ V-25								NOTAS
		<b>SE ELIMINAN</b>											
	P533001	Resistencia 6000 W., 230 V.		3	-								
	P533059	Cableado a resistencias		1	-								
	X183011	Contactador 3RT1024-1AN20, 230 V.		1	-								
	P533026	Cableado regletas a contactores		1	-								
		<b>SE INTRODUCEN</b>											
1	P445011	Cierre completo		-	1								
2	P535013	Inyector de vapor		-	1								
3	P505008	Tapon cierre completo		-	2								
4	P545011	Latiguillo de vapor L=600		-	1								
5	-	Arandela junta (con latiguillo)		-	2								
6	Z102301	Manguito doble 3/4"		-	2								
7	P535011	Electrovalvula vapor 3/4" ( 50 Hz.)		-	1								
7	P535021	Electrovalvula vapor 3/4" ( 60 Hz.)		-	1								
8	Q032031	Tornillo alomado M-5x10		-	2								
9	Q242030	Arandela abanico A-5		-	2								
10	Q302022	Arandela plana Ø16xØ6x1,2		-	2								
11	P535004	Soporte electrovalvula vapor		-	1								
12	Q221342	Remache exagonal M-5		-	2								
s/n	P535019	Manguera de vapor L=1500mm.		-	1								Maquina a red
s/n	U307031	Arandela junta Ø24xØ15x3		-	2								Maquina a red
s/n	P533054	Cableado electrovalvula vapor		-	1								











# LC-25

	1	2	3	4	5	6	7	8	9	10	11	12	13	14	15	16
STOP			X	X	X	X	X					X	X			
N40	X	X		X	X	X	X			X		X				
N60	X	X	X		X	X	X		X			X				
N90	X	X	X					X	X			X				
PP90	X	X	X		X	X	X		X			X	X			
PP60	X	X	X		X	X	X		X			X	X			
DEL	X	X	X		X			X		X		X	X			
LN	X	X		X				X				X	X	X		

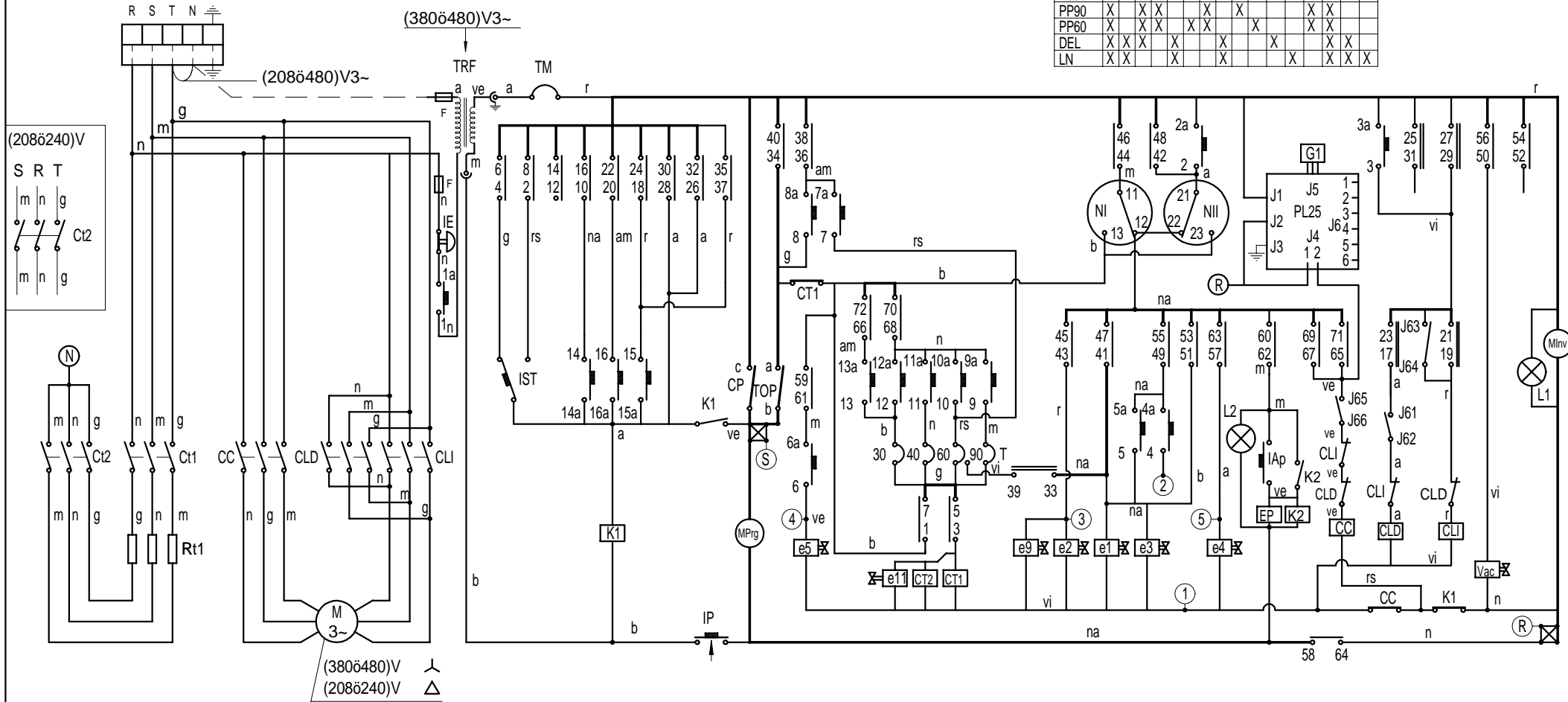



Esquema teorico adhesivo 400V 3N (Bajas revoluciones) 25Kg.		P-463007	
Pieza		Nº Clasificación	
Nº		Acabado	
Modificación		Propuesta de	
Modificación		Fecha	
Tolerancias generales			
① Modificar TRF		Maillio 23-7-01	
② Introducir conexion transformador		Maillio 12-9-01	
		$5 \pm$ : $50-100 \pm$ $5-25 \pm$ : $> 100 \pm$ $25-50 \pm$ : $\infty \pm$	
Firma		Fecha	
Dibujado S. N.		14-12-00	
Proyectado			
Comprobado			
Escala		Fagor Industrial, Koop. Elk. Mugatua	
		Mecanizado superficial	
		Plano numero	
		HC-30882 -2	
		Sustituye al Nº	
		Sustituido por	

LAVADORAS

ESPAÑOL

CONTACTOS PROGRAMADOR

-  Leva principal
-  Inversores
-  Conmutador

CODIGO DE COLORES:



- r = rojo
- a = azul
- m = marrón
- g = gris
- n = negro
- b = blanco
- vi = violeta
- am = amarillo
- na = naranja
- rs = rosa
- ve = verde
- am/ve = amarillo verde

COMPONENTES:

- CC- Contactor Centrifugado (7,10,14,25)
- CCL- Contactor Motor (55 Kg)
- CL- Contactor Lavado
- CLD- Contactor Lavado doha.
- CLJ- Contactor Lavado Izda.
- CT1,CT2- Contactor Calentamiento
- CVF- Contactor convertidor
- DP- Detector de posición
- e1- Electrov. Prelav. y aclarados
- e2- Electroválvula Lavado
- e3- Electrov. Prelav. y aclar. (25,55)
- e4- Electroválvula Suavizante
- e5- Electroválvula Lajía
- e6,7,8- Electrov. de equilibrio
- e9- Electrov. Jabón líquido (electronicas)
- e10- Electrov. Jabón líquido (55)
- e11- Electrov. Vapor (solo versión)
- EP- Electroiman de puerta
- F- Fusible
- FI- Filtro Interferencias
- G1, G2- Sensor galga
- IAP- Pulsador Apert. puerta
- IAR- Avance rapido
- IE- Pula. Parada de emergen. (25,55Kg.)
- IF- Interruptor de Flot
- IG- Interruptor general (selector)
- Im- Pulsador Start-Stop
- IP- Micro puerta
- IS- Interruptor de seguridad
- ISO- Interruptor sin centrif.
- IST- Puls. Marcha/Avan. rapido
- KB- Teclado programador
- K1- Rele avance rapido
- K2- Rele apertura puerta
- L1- Piloto Marcha
- L2- Piloto Apertura puerta
- L3- Piloto Sin centrifugado
- L4- Piloto Flot
- M- Motor
- MInv- Levas inversión
- MMO- Micro monedero
- Mo- Monedero
- MPrg- Levas principales
- NTC - Sensor de temperatura
- NI- Presostato Nivel bajo
- NIH- Presostato Nivel alto
- PI25- Circuito seguridad (25Kg.)
- RT1- Resistencia calentamiento
- RT2- Resist. calentam. (solo 55)
- T- Termostato 30, 40, 60, 90°C
- TM- Termico motor
- TRF- Transformador (versión 400V.3~)
- Vac- Válvula de Vacío
- VE- Ventilador de VF (solo 25,55)
- VF- Convertidor tensión/frecuencia
- VM- Ventilador de Motor (solo 55 Kg)
- ①...⑨- Puntos de conexión dosificadores

FRANÇAIS

CONTACTS PROGRAMMATEUR

-  Came principale
-  Renverseurs
-  Commutateur

CODES DE COULEURS:



- r = rouge
- a = bleu
- m = marron
- g = gris
- n = noir
- b = blanc
- vi = violet
- am = jaune
- na = orange
- rs = rose
- ve = vert
- am/ve = jaune/vert

COMPOSANTS:

- Contacteur centrifugé
- Contacteur moteur (55Kg)
- Contacteur lavage
- Contacteur lavage droit
- Contacteur lavage gauche
- Contacteur chauffage
- Contacteur convertisseur
- Détecteur de position
- Electrovalve de prélavage et rinçage
- Electrovalve de lavage
- Electrovalve de prélavage et rinçage (25,55)
- valve adouceseur
- Electrovalve javel
- Electrovalve d'équilibrage
- Electrovalve lessive liquide (electronique)
- Electrovalve lessive liquide (55)
- Electrovalve vapeur version seule-ent
- Electroaimant de porte
- Fusible
- Filtre interférences
- Senseur bride, jauge
- Commande d'ouverture des portes
- Avance rapide
- Interrupteur arrêt urgence (25,55Kg.)
- Interrupteur de flotteur
- Interrupteur général (selector)
- Bouton marche arrêt
- Micro porte
- Interrupteur de sécurité
- Interrupteur sans centrif.
- Commande d'avance rapide
- Clavier programmeur
- Relais avance rapide
- Relais ouverture de porte
- Pilote de mise en route
- Pilote d'ouverture de porte
- Pilote sans centrifugage
- Pilote de flotteur
- Moteur
- Cames renversement
- Micro monnseyur
- Monnseyur
- Monnseyur
- Cames principales
- Senseur de température
- Pressostat niveau bas
- Pressostat niveau haut
- Circuit de sécurité (25 Kg.)
- Résistance chauffage
- Résistance chauffage (seulement 55)
- Thermostat 30, 40, 60, 90°C
- Moteur thermique
- Transformateur (version 400V.3~)
- Valve de vidange
- Ventilateur de VF (seulement 25,55)
- Transformateur de tension/fréquence
- Ventilateur de moteur (seulement 55Kg)
- Points de branchements de dosificateurs

ENGLISH

PROGRAMMER CONTACTS

-  Main levy
-  Reverser
-  Commutator

COLOUR CODE



- r = red
- a = blue
- m = brown
- g = grey
- n = black
- b = white
- vi = violet
- am = yellow
- na = orange
- rs = pink
- ve = green
- am/ve = yellow-green

COMPONENTS:

- Spin relay (7,10,14,25)
- Motor relay (55Kg)
- Washing relay
- Right washing relay
- Left washing relay
- Heating relay
- Inverser relay
- Detector of position
- Prewashing and dardled solenoid valve
- Washing solenoid valve
- Prewashing and dardled solenoid valve (only 25, 55Kg)
- Softener solenoid valve
- Bleach solenoid valve
- Balanced solenoid valve
- Liquid soap solenoid valve (electronic)
- Liquid soap solenoid valve (only 55Kg)
- Steam solenoid valve (only version)
- Door electromagnet
- Fuse
- Interference filter
- Sensor
- Door opening switch
- Fast advance
- Emergency swich (25,55Kg.)
- Flot switch
- Main swich (selector)
- Start-Stop swich
- Door swich
- Security swich
- No spin swich
- Star/Fast advance swich
- Programmer keyboard
- Fast advance relay
- Door opening relay
- Start lamp
- Door opening lamp
- No spin lamp
- Flot lamp
- Motor
- Reverser levy
- Coin meter swich
- Coin meter
- Main levy
- Temperature sensor
- Low level presostat
- High level presostat
- Security circuit (25Kg.)
- Heating element
- Heating element (only 55Kg)
- Thermostat 30, 40, 60, 90°C
- Motor thermal protector
- Transformer (400V.3~version)
- Drain valve
- VF fan (only 25, 55Kg)
- Inverser
- Motor fan (only 55Kg)
- Doser connecting points

DEUTSCH

PROGRAMMIERKONTAKTE

-  Hauptnocken
-  Umschalter
-  Kommutator

FARBENCODE



- r = rot
- a = blau
- m = braun
- g = grau
- n = schwarz
- b = weiss
- vi = violett
- am = gelb
- na = oranger
- rs = rosa
- ve = grün
- am/ve = gelb/grün

KOMPONENTEN:

- Schleuderkontakt (7,10,14,25)
- Motorkontakt (55Kg)
- Waschkontakt
- Waschkontakt rechts
- Waschkontakt links
- Aufheizkontakt
- Umfomkontakt
- Positionsdetektor
- Elektroventil für Vorwaschen und Spülen
- Elektroventil für den Waschvorgang
- Elektroventil für Vorwaschen und Spülen
- Elektroventil für den Weichspülen
- Elektroventil für Laugen
- Ausgleich-Elektroventil
- Elektroventil für Flüssigwaschmittel
- Elektroventil für Flüssigwaschmittel
- Elektroventil (nur Version)
- Tür-Elektromagnet
- Sicherung
- Interferenzfilter
- Galga-Sensor
- Tür-Öffnungsknopf
- Schnellwaschg
- Notsschalter (25,55Kg.)
- Flot-Schalter
- Hauptschalter (Selector)
- Ein-und Ausschalter
- Türbedtätigung
- Sicherheitsschalter
- Schalter-ohne Schleudem
- Schalter f.Schnellwaschvorgang
- Programmschalter
- Relais f.d.Schnellwaschvorgang
- Türöffnungsrelais
- Startlichtanzeige
- Lichtanzeige f.d.Türöffnung
- Lichtanzeige-Ohne Schleudem
- Flot-Lichtanzeige
- Motor
- Umkehrnocken
- Münzeinwurfeschalter
- Münzeinwurf
- Hauptnocken
- Temperatursensor
- Niedrigdruckpresostat
- Hochdruckpresostat
- Sicherheitsschaltung (25Kg.)
- Heizsystem
- Heizsystemerwärmung (nur 55Kg)
- Thermostat 30, 40, 60, 90°C
- Wärmeschutzschaltermotor
- Transformator (400V.3~Version)
- Ablaufventil
- Ventilator (nur 25,55Kg)
- Druck-Frequenz umwandler
- Motorventilator (nur 55Kg)
- Konktionspunkte f.Dosierer

ITALIANO

CONTATTI PROGRAMMATORE

-  Leva principale
-  Invertitori
-  Commutatore

CODICE DEI COLORI:

- r = rosso
- a = azzurro
- m = marrone
- g = grigio
- n = nero
- b = bianco
- vi = viola
- am = giallo
- na = arancione
- rs = rosa
- ve = verde
- am/ve = giallo/verde

COMPONENTI:

- Contattore centrifuga (7,10,14,25)
- Contattore motore (55 Kg)
- Contattore lavaggio
- Contattore lavaggio destro
- Contattore lavaggio sinistro
- Contattore riscaldamento
- Contattore convertitore
- Detettore di posizione
- Electrovalvola prelavaggio e risciacquo
- Electrovalvola lavaggio
- Electrovalvola prelavaggio e risciacquo (25,55Kg)
- Electrovalvola ammorbidente
- Electrovalvola candeggina
- Electrovalvola di bilanciamento
- Electrovalvola detersivo liquido (electronico)
- Electrovalvola detersivo liquido (55)
- Electrovalvola vapore (solo versione)
- Elettrocalamita oblió
- F- Fusibile
- Filtro interferenze
- Sensore callibro
- Pulsante apertura porta
- Avanzamento rapido
- Pulsante arresto d'emergenza (25,55Kg.)
- Interruttore del galleggiante
- Interruttore generale
- Pulsante avvio/stop
- Micro porta
- Interruttore di sicurezza
- Interruttore senza centrifuga
- Pulsante funzionamento/avanzamento rapido
- Pulsantiera programmi
- Relais avanzamento rapido
- Relais apertura porta
- Spia funzionamento
- Spia apertura porta
- Spia esclusione centrifuga
- Spia galleggiante
- Motore
- Leve inversione
- Micro gettoniera
- Gettoniera
- Leve principali
- Sensore temperatura
- Pressostato livello basso
- Pressostato livello alto
- Circuito di sicurezza (25Kg.)
- Resistenza riscaldamento
- Resistenza riscaldamento (solo 55Kg)
- Termostato 30, 40, 60, 90°C
- Interruttore termico motore
- Transformatore (versione 400V.3~)
- Válvula di Svuotamento
- Ventilatore di VF (solo 25,55)
- Convertitore tensione/frequenza
- Ventilatore del motore (solo 55 Kg)
- Punti di connessione dosificatori