

Lavadoras - Washing machines - Lave linges

LC-7 ; LC-10 ; LC-14
LAC-7 ; LAC-10 ; LAC-14

OCTUBRE, 1999



Fagor Industrial, S. Coop.

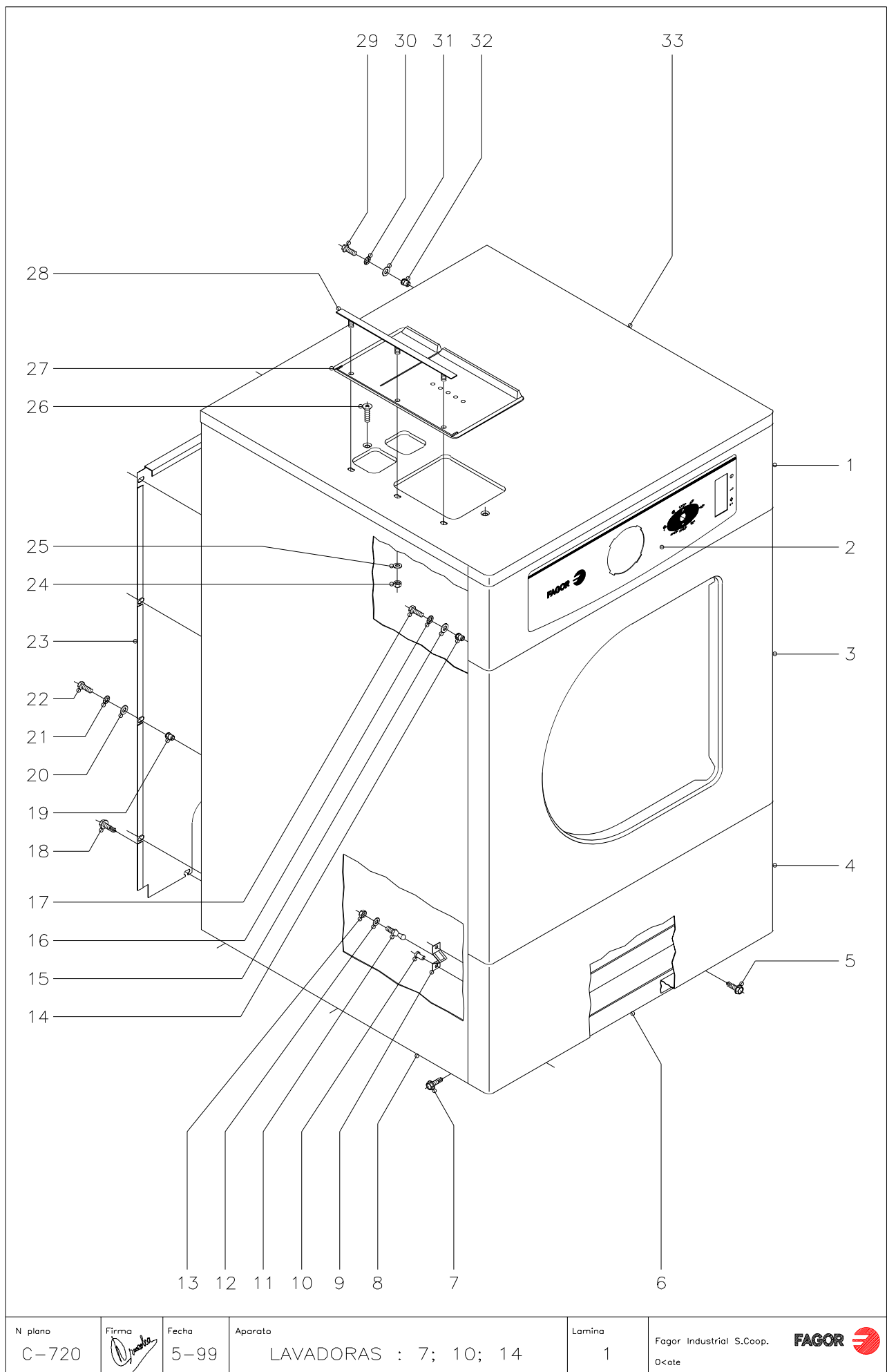

N plano C-720	Firma 	Fecha 5-99	Aparato LAVADORAS : 7; 10; 14	Lamina 1	Fagor Industrial S.Coop. FAGOR Ocate
------------------	-----------	---------------	----------------------------------	-------------	--

MOD.	LAVADORAS		ZONA	MUEBLE								PLANO		C-720
ITEM	CODIGO	DENOMINACION	TEXTO	LC-7 LAC-7	LAC-7 MP	LAC-7 MPP	LC-10 LAC-10	LAC-10 MP	LAC-10 MPP	LC-14 LAC-14	LAC-14 MP	LAC-14 MPP	NOTAS	
1	P500316	Portamandos		1	-	-	1	-	-	-	-	-		
1	P500320	Portamandos		-	1	1	-	1	1	-	-	-		
1	P520310	Portamandos		-	-	-	-	-	-	1	-	-		
1	P520311	Portamandos		-	-	-	-	-	-	-	1	1		
2	P500310	Embellecedor portamandos		1	-	-	1	-	-	1	-	-		
2	P500323	Embellecedor portamandos		-	1	-	-	1	-	-	1	-		
2	P500325	Embellecedor portamandos		-	-	1	-	-	1	-	-	1		
3	P500326	Panel frontal		1	1	1	1	1	1	-	-	-		
3	P520317	Panel frontal		-	-	-	-	-	-	1	1	1		
4	P500309	Suplemento panel frontal		1	1	1	1	1	1	-	-	-		
4	P520314	Suplemento panel frontal		-	-	-	-	-	-	1	1	1		
5	Q151323	Tornillo broca Ø4,8x16		2	2	2	2	2	2	2	2	2		
6	P500101	Armazón completo		1	1	1	-	-	-	-	-	-		
6	P510101	Armazón completo		-	-	-	1	1	1	-	-	-		
6	P520101	Armazón completo		-	-	-	-	-	-	1	1	1		
7	Q151323	Tornillo broca Ø4,8x16		6	6	6	6	6	6	6	6	6		
8	P500300	Panel lateral completo		2	2	2	-	-	-	-	-	-		
8	P510300	Panel lateral completo		-	-	-	2	2	2	-	-	-		
8	P520300	Panel lateral completo		-	-	-	-	-	-	2	2	2		
9	X010503	Muelle enganche pitón		2	2	2	2	2	2	2	2	2		
10	Q419007	Remache tubular Ø3,2x6		4	4	4	4	4	4	4	4	4		
11	P450303	Pitón enganche		2	2	2	2	2	2	2	2	2		
12	Q232030	Arandela plana A.5		2	2	2	2	2	2	2	2	2		
13	Q221308	Tuerca exag. autoseguro M.5		2	2	2	2	2	2	2	2	2		
14	Q221342	Remache exagonal M.5		6	6	6	6	6	6	6	6	6		
15	Q302022	Arandela plana Ø16xØ6x1,2		6	6	6	6	6	6	6	6	6		
16	Q242030	Arandela abanico A.5		6	6	6	6	6	6	6	6	6		
17	Q012031	Tornillo exagonal M.5x10		6	6	6	6	6	6	6	6	6		
18	Q151323	Tornillo broca Ø4,8x16		3	3	3	3	3	3	3	3	3		

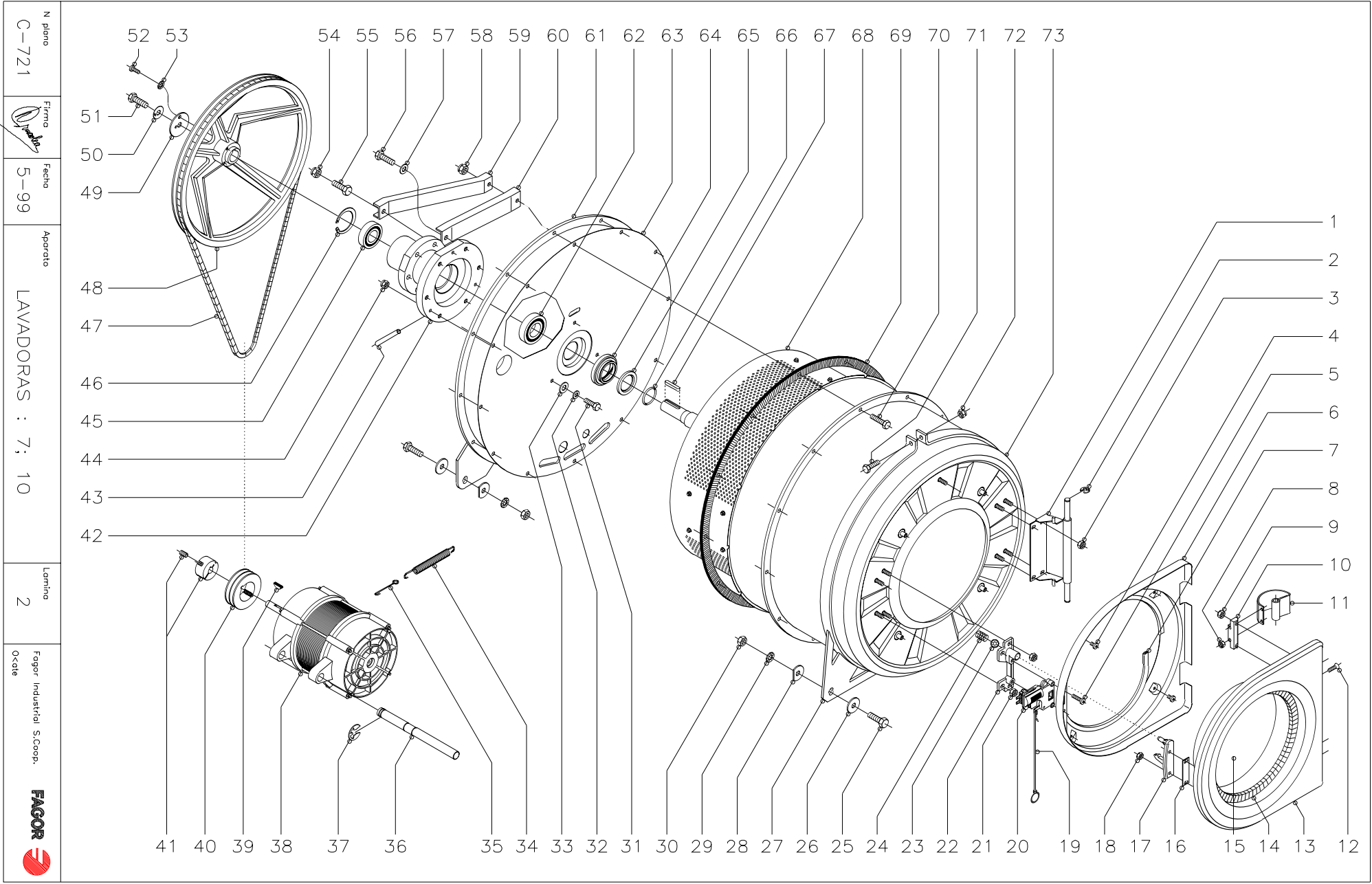

N plano	C-721
Firma	
Fecha	5-99
Apartado	LAVADORAS : 7; 10
Laminado	2
Fecha Industrial S.Coop.	Ocala

MOD.		LAVADORAS	ZONA	PARTE FUNCIONAL MECANICA				PLANO	C-721					
ITEM	CODIGO	DENOMINACION	TEXTO	LC-7	LC-10	LAC-7	LAC-10							NOTAS
1	P500511	Soporte bisagra		1	1	1	1							
2	Q271006	Arandela de seguridad Ø8		2	2	2	2							
3	Q222012	Tuerca autoblocante M.6		4	4	4	4							
4	Q032031	Tornillo alomado M.5x10		4	4	4	4							
5	Q032035	Tornillo alomado M.5x30		2	2	2	2							
6	P500327	Fondo puerta		1	1	1	1							
7	3673700	Perfil goma gris en "U" 12x6x1030		1	1	1	1							
8	Q222030	Tuerca autoblocante M.5		4	4	4	4							
9	Q222012	Tuerca autoblocante M.6		4	4	4	4							
10	P500504	Sujeción bisagra		2	2	2	2							
11	P500502	Bisagra puerta		2	2	2	2							
12	Q062035	Tornillo allen. 3 avellanado M.5x30		4	4	4	4							
13	P500500	Marco de puerta		1	1	1	1							
14	P440502	Junta de puerta		1	1	1	1							
15	P440503	Mirilla de puerta		1	1	1	1							
16	P500512	Calzo pestillo		1	1	1	1							
17	P500513	Pestillo de puerta		1	1	1	1							
18	Q222012	Tuerca autoblocante M.6		2	2	2	2							
19	P446116	Palanca apertura manual puerta		1	1	1	1							
20	P443006	Cierre de puerta		1	1	1	1							
s/n	P443057	Protector de cierre (plástico)		1	1	1	1							
21	Q222012	Tuerca autoblocante M.6		4	4	4	4							
22	P446113	Soporte cierre		1	1	1	1							
23	Z700613	Bola Ø12		1	1	1	1							
24	Z700603	Muelle		1	1	1	1							
25	Q011376	Tornillo exagonal M.12x40		4	4	4	4							
26	Q301313	Arandela plana Ø38xØ12x3		6	6	6	6							
27	P446110	Anillo anterior soporte cuba		1	1	1	1							
28	P446119	Arandela con muesca		2	2	2	2							

MOD.		LAVADORAS	ZONA	PARTE FUNCIONAL MECANICA				PLANO	C-721					
ITEM	CODIGO	DENOMINACION	TEXTO	LC-7	LC-10	LAC-7	LAC-10							NOTAS
29	Q301025	Arandela abanico A.12		4	4	4	4							
30	Q162070	Tuerca exagonal M.12		4	4	4	4							
31	Q012046	Tornillo exagonal M.6x40		3	3	3	3							
32	Q232040	Arandela plana A.6		3	3	3	3							
33	Q304040	Arandela de estanq. Ø6,4x10,4x1		3	3	3	3							
34	P445912	Resorte tensor de motor		1	1	1	1							
35	P445915	Alargadera resorte tensor		1	1	1	1							
36	P505902	Eje soporte motor		1	1	1	1							
37	Q271027	Arandela de seguridad Ø15		4	4	4	4							
38	P505903	Motor 230/400 V50 Hz.		1	-	1	-							
38	P515901	Motor 230/400 V50 Hz.		-	1	-	1							
39	Q563005	Lengüeta redondo 5x9		1	1	1	1							
40	P435903	Polea motor 50Hz.		1	1	-	-							
40	P435905	Polea motor 60Hz.		1	1	-	-							
40	P505905	Polea motor		-	-	1	1							
41	P435904	Casquillo polea con tornillos		1	1	-	-							
41	P505904	Casquillo polea con tornillos		-	-	1	1							
42	P506001	Soporte rodamientos		1	-	1	-							
42	P516001	Soporte rodamientos		-	1	-	1							
43	P446019	Tubo Ø10xØ8x100		1	1	1	1							
44	Q221301	Tuerca autoseguro M.6		3	3	3	3							
45	P446011	Rodamiento 6206-2ZC3		1	2	1	2							
46	Q301028	Anillo de seguridad Ø62x2		1	1	1	1							
47	P445914	Correa SPZ LW-1800		1	1	1	1							
48	P506002	Polea tambor		1	1	1	1							
49	P446016	Arandela fijación polea		1	1	1	1							
50	Q301329	Arandela de seguridad		1	1	1	1							
51	Q151341	Tornillo exagonal M.12x35		1	1	1	1							
52	Q032041	Tornillo alomado M.6x10		1	1	1	1							

MOD.		LAVADORAS	ZONA	PARTE FUNCIONAL MECANICA				PLANO	C-721					
ITEM	CODIGO	DENOMINACION	TEXTO	LC-7	LC-10	LAC-7	LAC-10							NOTAS
53	Q242040	Arandela abanico A.6		1	1	1	1							
54	Q221306	Tuerca autoseguro M.10		6	6	6	6							
55	Q011366	Tornillo exagonal M.10x40		6	6	6	6							
56	Q011364	Tornillo exagonal M.10x25		6	6	6	6							
57	Q232060	Arandela A.10		6	6	6	6							
58	Q221309	Tuerca autoseguro M.8		12	12	12	12							
59	P446021	Refuerzo superior fondo cuba		6	6	6	6							
60	P446020	Refuerzo inferior fondo cuba		6	6	6	6							
61	P446003	Anillo posterior soporte cuba		1	1	1	1							
62	P446010	Rodamiento 6207-2RSC3		1	2	1	2							
63	P506007	Fondo de cuba		1	1	1	1							
64	P446005	Reten simrax Ax5 47-75-13		1	1	1	1							
65	P444911	Disco apoyo reten		1	1	1	1							
66	P444912	Junta tórica 40x1,5		1	1	1	1							
67	P446017	Lengüeta de ajuste A8x7x45		1	1	1	1							
68	P434907	Tambor completo		1	-	-	-							
68	P444913	Tambor completo		-	1	-	-							
68	P504902	Tambor completo		-	-	1	-							
68	P514906	Tambor completo		-	-	-	1							
69	P506103	Junta de cuba		1	1	1	1							
70	Q012056	Tornillo exagonal M.8x40		12	12	12	12							
71	Q012056	Tornillo exagonal M.8x40		1	1	1	1							
72	Q221309	Tuerca autoseguro M.8		1	1	1	1							
73	P506102	Cuba completa		1	-	1	-							
	P516102	Cuba completa		-	1	-	1							

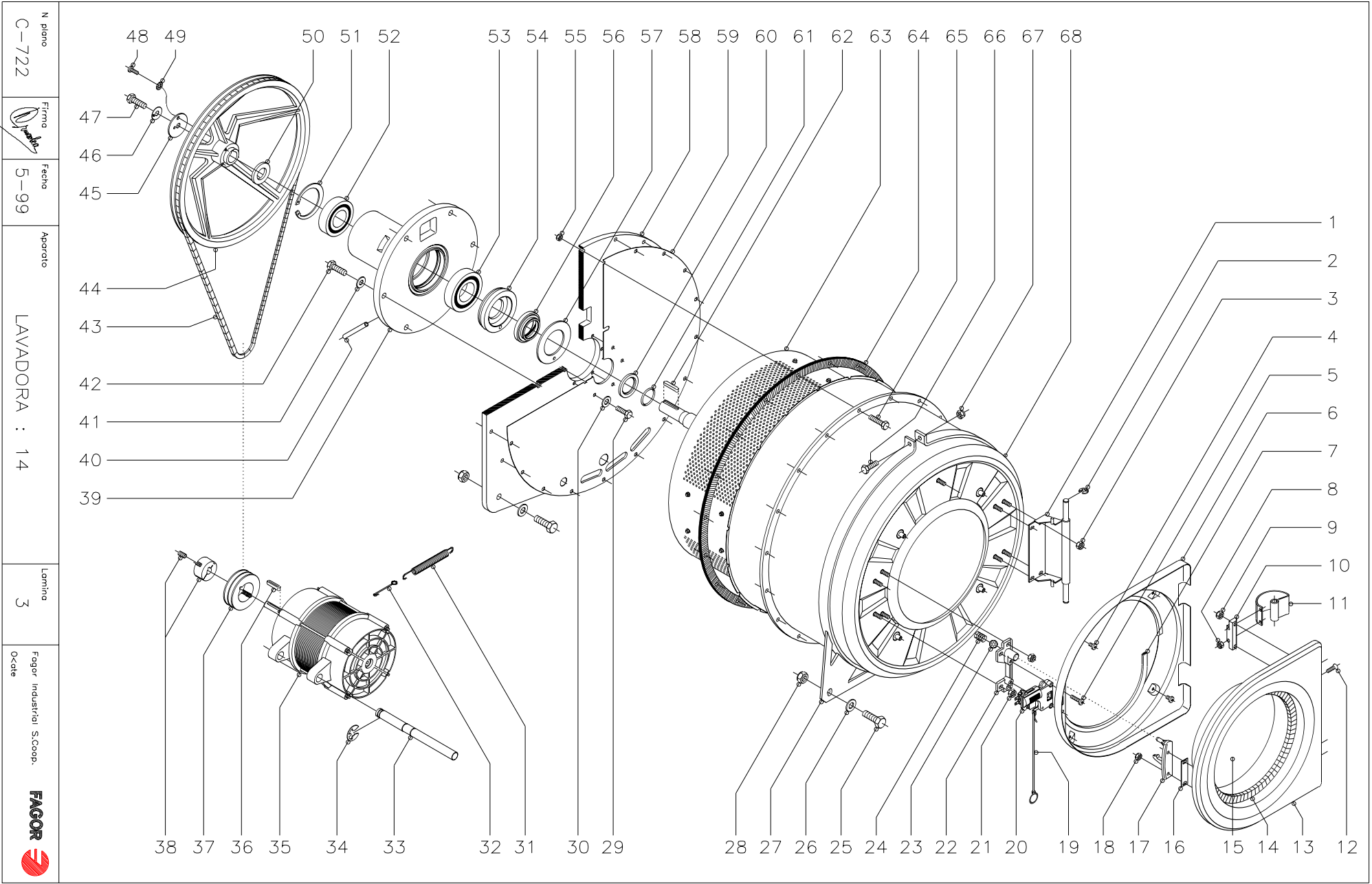

N. plano
C-722

Firma
Fagor

Fecha
5-99

Aparato
LAVADORA : 14

Laminio
3

Fagor Industrial S.Coop.
O.cite

FAGOR

MOD.		LAVADORAS	ZONA	PARTE FUNCIONAL MECANICA				PLANO	C-722
ITEM	CODIGO	DENOMINACION	TEXTO	LC-14	LAC-14				NOTAS
1	P500511	Soporte bisagra		1	1				
2	Q271006	Arandela de seguridad Ø8		2	2				
3	Q222012	Tuerca autoblocante M.6		4	4				
4	Q032031	Tornillo alomado M.5x10		4	4				
5	Q032035	Tornillo alomado M.5x30		2	2				
6	P500327	Fondo puerta		1	1				
7	3673700	Perfil goma gris en "U" 12x6x1030		1	1				
8	Q222030	Tuerca autoblocante M.5		4	4				
9	Q222012	Tuerca autoblocante M.6		4	4				
10	P500504	Sujeción bisagra		2	2				
11	P500502	Bisagra puerta		2	2				
12	Q062035	Tornillo allen 3 avellanado M.5x30		4	4				
13	P500500	Marco de puerta		1	1				
14	P440502	Junta de puerta		1	1				
15	P440503	Mirilla de puerta		1	1				
16	P500512	Calzo pestillo		1	1				
17	P500513	Pestillo de puerta		1	1				
18	Q222012	Tuerca autoblocante M.6		2	2				
19	P446116	Palanca apertura manual puerta		1	1				
20	P443006	Cierre de puerta		1	1				
s/n	P443057	Protector de cierre (plástico)		1	1				
21	Q222012	Tuerca autoblocante M.6		4	4				
22	P446113	Soporte cierre		1	1				
23	Z700613	Bola Ø12		1	1				
24	Z700603	Muelle		1	1				
25	Q011387	Tornillo exagonal M.14x50		4	4				
26	Q301380	Arandela plana A.15		4	4				
27	P456106	Anillo anterior soporte cuba		1	1				
28	Q221338	Tuerca autoseguro M.14		2	2				

MOD.		LAVADORAS	ZONA	PARTE FUNCIONAL MECANICA				PLANO	C-722	
ITEM	CODIGO	DENOMINACION	TEXTO	LC-14	LAC-14					NOTAS
29	Q012042	Tornillo exagonal M.6x15		6	6					
30	Q304040	Arandela de estanq. Ø4,5x10,4x1		6	6					
31	P445912	Resorte tensor de motor		1	1					
32	P445915	Alargadera resorte tensor		1	1					
33	P525905	Eje soporte motor		1	1					
34	Q271027	Arandela de seguridad Ø15		4	4					
35	P525902	Motor 230/400V. 50 HZ.		1	1					
36	P455960	Lengüeta A-8x7x40 DIN 6885		1	1					
37	P435903	Polea motor 50HZ		1	-					
37	P435905	Polea motor 60 HZ		1	-					
37	P505905	Polea motor 50 HZ		-	1					
38	P455904	Casquillo polea con tornillos		1	-					
38	P525904	Casquillo polea con tornillos		-	1					
39	P526001	Soporte rodamientos		1	1					
40	P446019	Tubo Ø10xØ8x100		1	1					
41	Q301010	Arandela Ø27xØ12,5x2,5		6	6					
42	Q151341	Tornillo exagonal M.12x35		6	6					
43	P455914	Correa SP2 1887 LW		2	2					
44	P506002	Polea tambor		1	1					
45	P446016	Arandela fijación polea		1	1					
46	Q301329	Arandela de seguridad		1	1					
47	Q151341	Tornillo exagonal M.12x35		1	1					
48	Q032041	Tornillo alomado M.6x10		1	1					
49	Q242040	Arandela abanico A.6		1	1					
50	P526005	Casquillo		1	1					
51	Q301030	Anillo de seguridad Ø90		1	1					
52	P305934	Rodamiento 6308 2Z		1	1					
53	P305933	Rodamiento 6309 2RS		1	1					

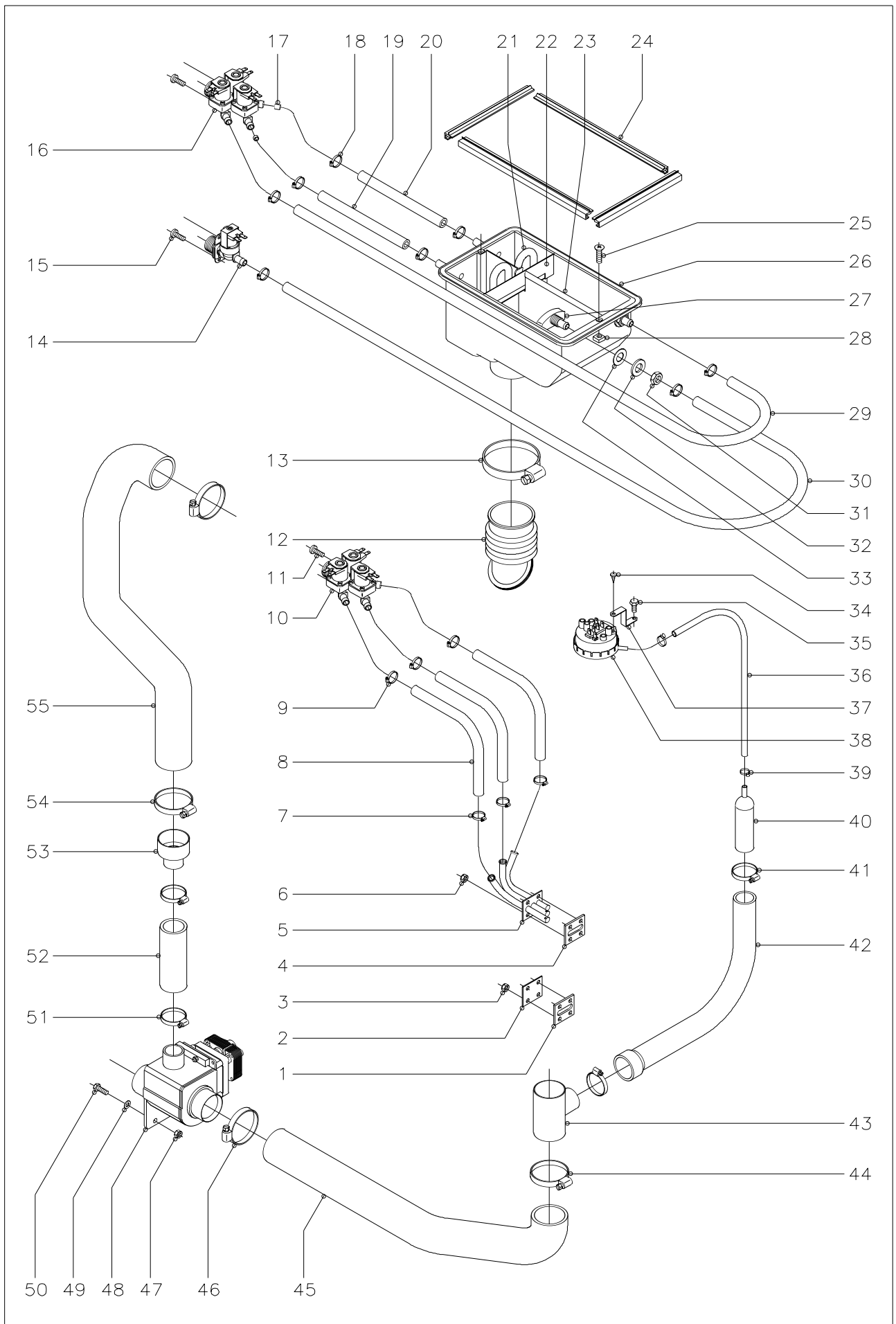

N plano C-723	Firma <i>D. J. J. J.</i>	Fecha 5-99	Aparato LAVADORAS : 7, 10, 14	Lamina 4	Fagor Industrial S.Coop. FAGOR 0cate
------------------	-----------------------------	---------------	----------------------------------	-------------	--

MOD.		LAVADORAS		ZONA		PARTE FUNCIONAL HIDRAULICA						PLANO		C-723		
ITEM	CODIGO	DENOMINACION	TEXTO	LC-7	LAC-7	LAC-7 MP	LAC-7 MPP	LC-10	LAC-10	LAC-10 MP	LAC-10 MPP	LC-14	LAC-14	LAC-14 MP	LAC-14 MPP	NOTAS
1	P505003	Junta inyectores		1	-	-		1	-	-		1	-	-		
2	P435001	Tapa junta		1	-	-		1	-	-		1	-	-		
3	Q222012	Tuerca autoblocante M.6		4	-	-		4	-	-		4	-	-		
4	P505003	Junta inyectores		-	1	1		-	1	1		-	1	1		
5	P505004	Inyector completo		-	1	1		-	1	1		-	1	1		
6	Q222012	Tuerca autoblocante M.6		-	4	4		-	4	4		-	4	4		
7	Q881302	Abrazadera 12-20		-	3	3		-	3	3		-	3	3		
8	3676900	Tubo de goma Ø17xØ10x380		-	3	3		-	3	3		-	-	-		
8	3676900	Tubo de goma Ø17xØ10x500		-	-	-		-	-	-		-	3	3		
9	Q881302	Abrazadera 12-20		-	3	3		-	3	3		-	3	3		
10	Z611123	Electroválvula triple		-	1	1		-	1	1		-	1	1		
11	Q151320	Tornillo alomado M.4x6		-	2	2		-	2	2		-	2	2		
12	P440709	Conducto cubeta a cuba		1	1	1		1	1	1		1	1	1		
13	Q881335	Abrazadera 60-80		1	1	1		1	1	1		1	1	1		
14	Z701135	Electroválvula simple		1	1	1		1	1	1		1	1	1		
15	Q151320	Tornillo alomado M.4x6		4	4	4		4	4	4		4	4	4		
16	Z611123	Electroválvula triple		1	1	1		1	1	1		1	1	1		
17	P443042	Regulador caudal (3l/min.)		2	2	2		2	2	2		2	2	2		
18	Q881302	Abrazadera 12-20		8	8	8		8	8	8		8	8	8		
19	3676900	Tubo de goma Ø17xØ10x230		1	1	1		-	-	-		-	-	-		Cubeta lejía.
19	3676900	Tubo de goma Ø17xØ10x380		-	-	-		1	1	1		-	-	-		Cubeta lejía.
19	3676900	Tubo de goma Ø17xØ10x450		-	-	-		-	-	-		1	1	1		Cubeta lejía.
20	3676900	Tubo de goma Ø17xØ10x230		1	1	1		-	-	-		-	-	-		Suavizante.
20	3676900	Tubo de goma Ø17xØ10x380		-	-	-		1	1	1		-	-	-		Suavizante.
20	3676900	Tubo de goma Ø17xØ10x450		-	-	-		-	-	-		1	1	1		Suavizante.
21	P440702	Tubo sifón		2	2	2		2	2	2		2	2	2		
22	P440715	Escuadra protección		1	1	1		1	1	1		1	1	1		
23	P440721	Perfil refuerzo		1	1	1		1	1	1		1	1	1		
24	3715000	Perfil cierre cubeta L=1m.		1	1	1		1	1	1		1	1	1		

MOD.		LAVADORAS		ZONA		PARTE FUNCIONAL HIDRAULICA						PLANO		C-723		
ITEM	CODIGO	DENOMINACION	TEXTO	LC-7	LAC-7	LAC-7 MP	LAC-7 MPP	LC-10	LAC-10	LAC-10 MP	LAC-10 MPP	LC-14	LAC-14	LAC-14 MP	LAC-14 MPP	NOTAS
25	Q152019	Tornillo avellanado M.4x15		2	2	2	2	2	2	2	2	2	2	2	2	
26	P440700	Cubeta de detergentes		1	1	1	1	1	1	1	1	1	1	1	1	
27	P440701	Difusor de detergentes		2	2	2	2	2	2	2	2	2	2	2	2	
28	Q222004	Tuerca cuadrada M.4		2	2	2	2	2	2	2	2	2	2	2	2	
29	3676900	Tubo de goma Ø17xØ10x700		1	1	1	-	-	-	-	-	-	-	-	-	Cubeta prelavado.
29	3676900	Tubo de goma Ø17xØ10x850		-	-	-	1	1	1	-	-	-	-	-	-	Cubeta prelavado.
29	3676900	Tubo de goma Ø17xØ10x900		-	-	-	-	-	-	-	1	1	1	1	1	Cubeta prelavado.
30	3676900	Tubo de goma Ø17xØ10x700		1	1	1	-	-	-	-	-	-	-	-	-	Cubeta lavado.
30	3676900	Tubo de goma Ø17xØ10x850		-	-	-	1	1	1	-	-	-	-	-	-	Cubeta lavado.
30	3676900	Tubo de goma Ø17xØ10x900		-	-	-	-	-	-	-	1	1	1	1	1	Cubeta lavado.
31	Q223018	Tuerca exagonal M.16x1,5		2	2	2	2	2	2	2	2	2	2	2	2	
32	Q301302	Arandela plana A.17		2	2	2	2	2	2	2	2	2	2	2	2	
33	Q307002	Arandela junta		2	2	2	2	2	2	2	2	2	2	2	2	
34	Q082032	Tornillo alomado BZ-3,5x9,5		1	1	-	1	1	-	1	1	1	1	-	-	
35	Q012031	Tornillo exagonal M.5x10		1	1	-	1	1	-	1	1	1	1	1	-	
36	3702400	Tubo goma negra Ø8xØ4x1000		1	1	1	1	1	1	1	1	1	1	1	1	
37	Z602923	Soporte presostato		1	1	-	1	1	-	1	1	1	1	-	-	
38	P503008	Presostato		1	1	-	1	1	-	1	1	1	1	-	-	
39	Z704061	Brida cremallera		2	2	2	2	2	2	2	2	2	2	2	2	
40	P445002	Camara presostato		1	1	1	1	1	1	1	1	1	1	1	1	
41	Q881306	Abrazadera 32-50		2	2	2	2	2	2	2	2	2	2	2	2	
42	P445001	Codo de presostato		1	1	1	1	1	1	1	1	1	1	1	1	
43	-	Toma presión		1	1	1	1	1	1	1	1	1	1	1	1	Soldado a cuba.
44	Q881324	Abrazadera 50-70		1	1	1	1	1	1	1	1	1	1	1	1	
45	P455000	Conducto desagüe		1	1	1	1	1	1	1	-	-	-	-	-	
45	P455001	Conducto rebosadero		-	-	-	-	-	-	-	1	1	1	1	1	
46	Q881324	Abrazadera 50-70		1	1	1	1	1	1	1	1	1	1	1	1	
47	Q221308	Tuerca autoseguro M.5		2	2	2	2	2	2	2	2	2	2	2	2	
48	P302120	Válvula vaciado		1	1	1	1	1	1	1	1	1	1	1	1	

N plano
 C-724
 Firma
 Fecha
 5-99
 Aparato
 LAVADORAS LC-7, 10, 14
 Laminas
 5
 Fagor Industrial S.Coop.
 O-ate
FAGOR

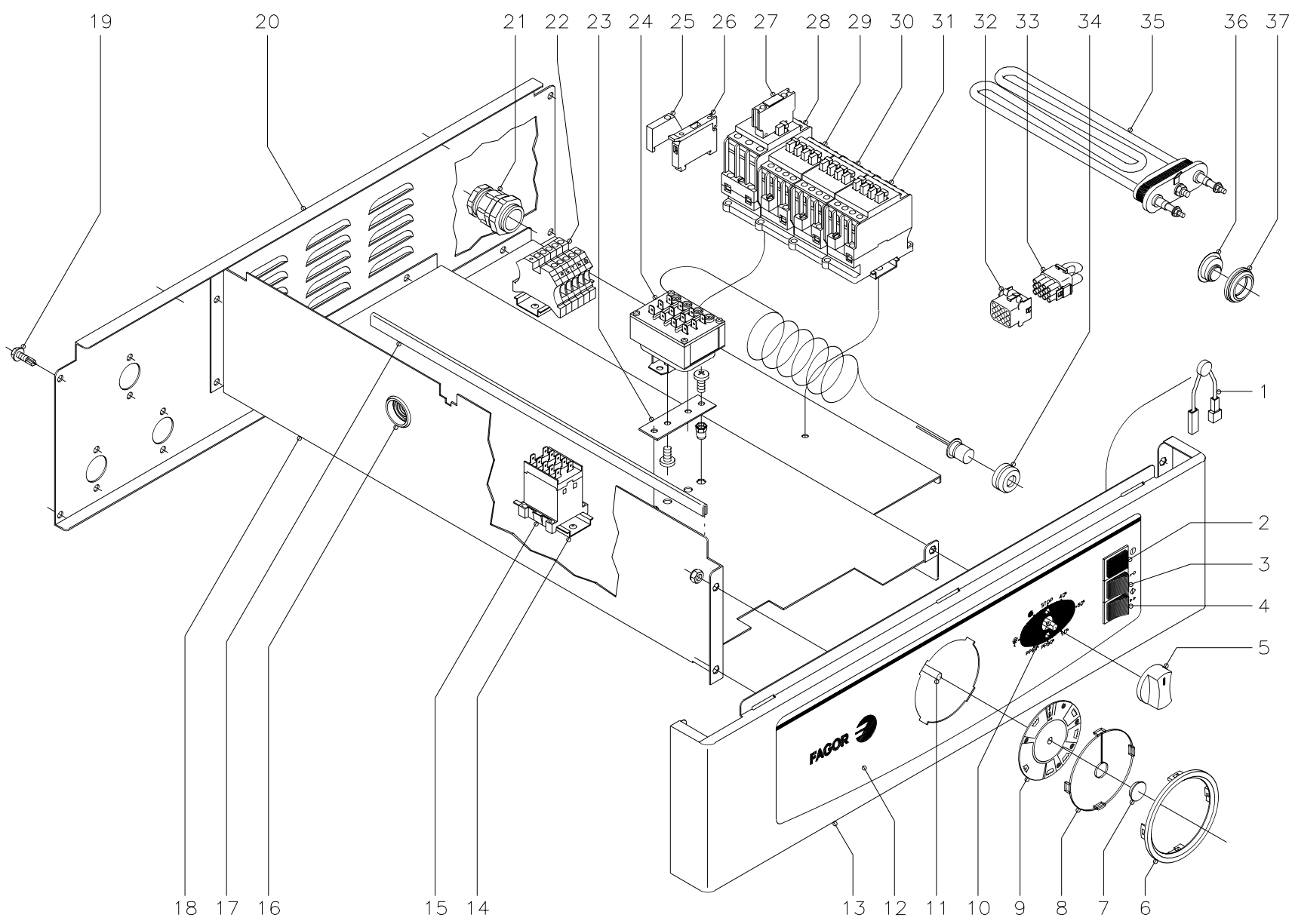

MOD.		LAVADORAS		ZONA		PARTE FUNCIONAL ELECTRICA				PLANO		C-724	
ITEM	CODIGO	DENOMINACION	TEXTO	LC-7	LC-10	LC-14							NOTAS
1	P503019	Cableado PTC		1	1	1							
2	P503004	Piloto rojo		1	1	1							
3	P503005	Pulsador verde (puerta)		1	1	1							
4	P503006	Pulsador blanco (start)		1	1	1							
5	R663062	Botón de mando completo		1	1	1							
6	P440336	Marco mirilla		1	1	1							
7	P302882	Embellecedor disco programador		1	1	1							
8	P500315	Mirilla de disco		1	1	1							
9	P500314	Disco programador		1	1	1							
10	P433023	Conmutador 8 posiciones		1	1	1							
	Z602906	Casquillo		2	2	2							Amarre conmutad.
	Q041324	Tornillo avellanado M.4x25		2	2	2							Amarre conmutad.
11	P433004	Programador rotativo		1	1	1							
	Q151320	Tornillo alomado M.4x6		4	4	4							
	Q242020	Arandela abanico A.4		4	4	4							
12	P500310	Embellecedor portamandos		1	1	1							
13	P500316	Portamandos		1	1	-							
13	P520310	Portamandos		-	-	1							
14	Z103083	Guía contactor L=73		1	1	1							
15	Z683087	Contacto 230V.		1	1	1							
16	X723014	Pasamuros Ø30		1	1	1							
17	3673700	Perfil goma gris en "U" 12x6x700		1	1	1							
18	P503003	Soporte cuadro eléctrico		1	-	-							
18	P513001	Soporte cuadro eléctrico		-	1	-							
18	P523001	Soporte cuadro eléctrico		-	-	1							
19	Q151323	Tornillo broca Ø4,8x16		9	9	9							
20	P500304	Soporte electroválvulas		1	1	-							
20	P520304	Soporte electroválvulas		-	-	1							
21	R023013	Prensaestopas		1	1	1							

MOD.		LAVADORAS		ZONA		PARTE FUNCIONAL ELECTRICA					PLANO		C-724
ITEM	CODIGO	DENOMINACION	TEXTO	LC-7	LC-10	LC-14							NOTAS
22	P453025	Borne fases (gris)		3	3	3							
	Z263302	Borna neutro (azul)		1	1	1							
	P453026	Borna tierra (verde-amarillo)		1	1	1							
	Z263303	Tope final		1	1	1							
	Z103083	Guía contactor L=73		1	1	1							
23	P453020	Sujección termostato		1	1	1							
	Q021331	Tornillo alomado M.5x10		2	2	2							
	Q221342	Remache exagonal M.5		2	2	2							
24	P433018	Termostato		1	1	1							
	Q032021	Tornillo alomado M.4x10		2	2	2							
25	Z263303	Tope final		1	1	1							
26	R073005	Borna portafusible		1	1	1							
s/n	P184011	Cartucho fusible 4A		1	1	1							
27	P443080	Bloque contacto auxiliar		1	1	1							Amarre conmutad.
28	X183011	Contacto calentamiento		1	1	1							Amarre conmutad.
29	P433030	Contacto centrifugado		1	1	1							
30	P433030	Contacto lavado derecha		1	1	1							
31	P433030	Contacto lavado izquierda		1	1	1							
s/n	Z123019	Guía contactor L=175		1	1	1							
32	R243010	Conector hembra 12 vías		1	1	1							
33	R433013	Selección estándar		1	1	1							
34	Z703048	Pasamuros bulbo termostato		1	1	1							
35	P103012	Resistencia 2000W 230V.		3	-	-							
35	P143002	Resistencia 3000W 230V.		-	3	-							
35	P183002	Resistencia 4000W 230V.		-	-	3							
36	P443060	Tapón		1	1	1							
37	N503017	Soporte termostato		1	1	1							

MOD.	LAVADORAS		ZONA	VARIOS			PLANO						
ITEM	CODIGO	DENOMINACION	TEXTO	LC-7	LC-10	LC-14							NOTAS
	Z206121	Placa matricula		1	1	1							
	P506501	Folleto de instrucciones		1	1	1							
	Z602121	Manguera entrada de agua		2	2	2							
	P506502	Plantilla de anclaje de 7		1	-	-							
	P516501	Plantilla de anclaje de 10		-	1	-							
	P526501	Plantilla de anclaje de 14		-	-	1							
	P503016	Plano de montaje eléctrico		1	1	1							HD-30.370-1
	P433031	Esquema eléctrico adhesivo		1	1	1							HC-30.690
	P503014	Instalación base		1	1	1							
	P463002	Instalación bajo centrifugado		1	1	1							
	P503018	Cableado a resistencias		1	1	1							
	P503035	Cableado motor		1	1	1							
	X323005	Cableado regleta-contactores		1	-	-							
	P533026	Cableado regleta-contactores		-	1	1							

N plano
C-725

Firma
Fagor

Fecha
5-99

Aparato
LAVADORAS LAC-7, 10, 14

Laminas
6

Fagor Industrial S.Coop.
O<die

FAGOR

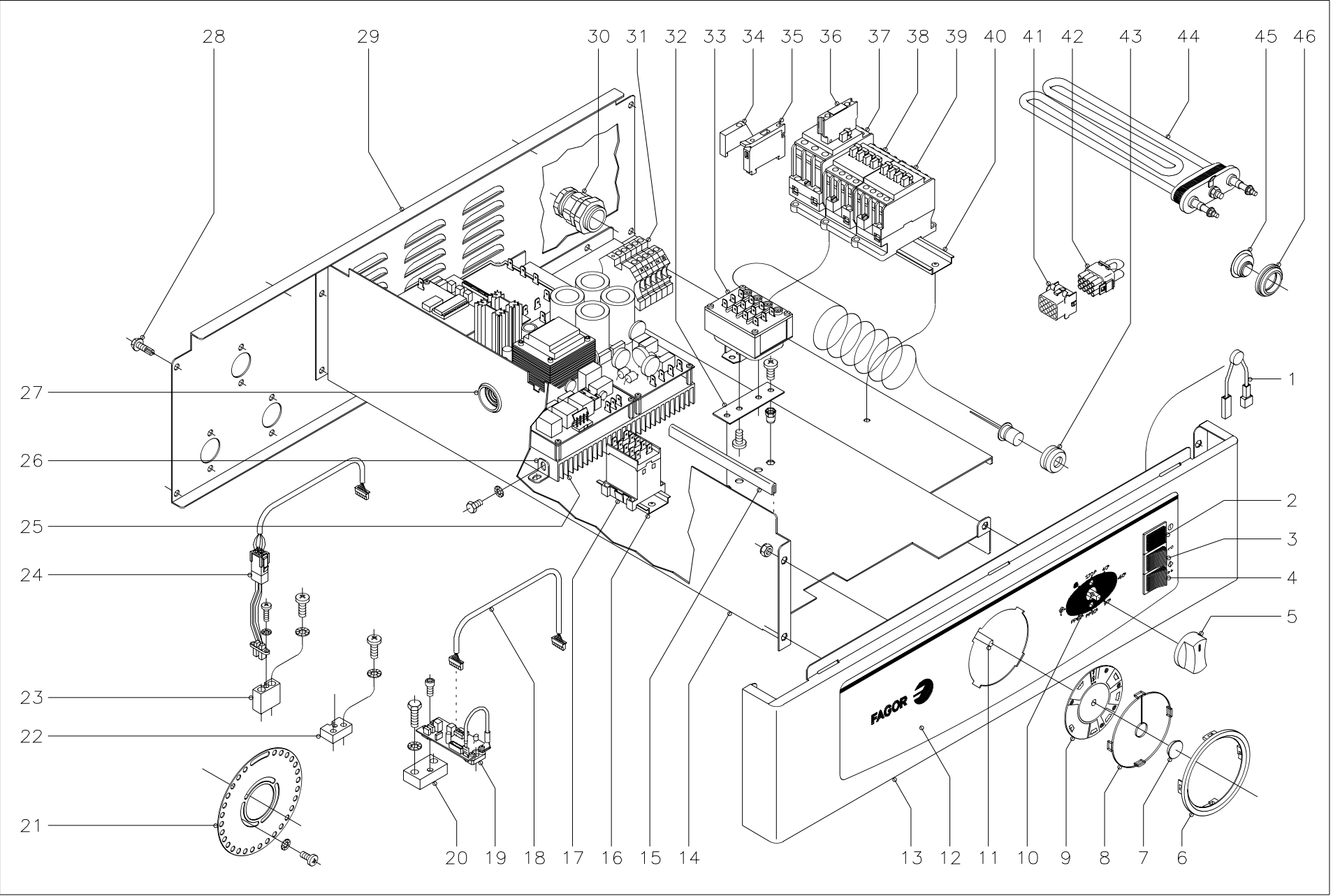

28

29

30

31

32

33

34

35

36

37

38

39

40

41

42

43

44

45

46

27

26

25

24

23

22

21

20

19

18

17

16

15

14

13

12

11

10

9

8

7

6

1

2

3

4

5

MOD.		LAVADORAS		ZONA		PARTE FUNCIONAL ELECTRICA				PLANO		C-725	
ITEM	CODIGO	DENOMINACION	TEXTO	LAC-7	LAC-10	LAC-14							NOTAS
1	P503019	Cableado PTC		1	1	1							
2	P503004	Piloto rojo		1	1	1							
3	P503005	Pulsador verde (puerta)		1	1	1							
4	P503006	Pulsador blanco (avance)		1	1	1							
5	R663062	Botón de mando completo		1	1	1							
6	P440336	Marco mirilla		1	1	1							
7	P302882	Embellecedor disco programador		1	1	1							
8	P500315	Mirilla de disco		1	1	1							
9	P500314	Disco programador		1	1	1							
10	P433023	Conmutador 8 posiciones		1	1	1							
	Z602906	Casquillo		2	2	2							Amarre conmut.
	Q041324	Tornillo avellanado M.4x25		2	2	2							Amarre conmut.
11	P433004	Programador rotativo		1	1	1							
	Q151320	Tornillo alomado M.4x6		4	4	4							Amarre program.
	Q242020	Arandela abanico A.4		4	4	4							Amarre program.
12	P500310	Embellecedor portamandos		1	1	1							
13	P500316	Portamandos		1	1	-							
13	P520310	Portamandos		-	-	1							
14	P503003	Soporte cuadro eléctrico		1	-	-							
14	P513001	Soporte cuadro eléctrico		-	1	-							
14	P523001	Soporte cuadro eléctrico		-	-	1							
15	3673700	Perfil goma gris en "U" 12x6x700		1	1	1							
16	Z103083	Guía contactor L=73		1	1	1							
17	Z683087	Contactador 230 V.		1	1	1							
18	P503028	Cableado sensor		2	2	2							
19	P533016	Sensor galga liar		2	2	2							
	Q122031	Tornillo allen M.5x10		4	4	4							Amarre sensor.
20	P526006	Calzo sensor		-	-	1							
	Q242040	Arandela abanico A.6		-	-	2							Amarre calzo a portarrodamientos.

MOD.		LAVADORAS		ZONA		PARTE FUNCIONAL ELECTRICA				PLANO		C-725	
ITEM	CODIGO	DENOMINACION	TEXTO	LAC-7	LAC-10	LAC-14							NOTAS
	Q012043	Tornillo exagonal M.6x20		-	-	2							Amarre calzo a portarrodamientos
21	P506006	Disco detector		1	1	1							
	Q242020	Arandela abanico A.4		3	3	3							
	Q153021	Tornillo alomado M.4x10		3	3	3							
22	P526007	Soporte detector		-	-	1							
	Q242020	Arandela abanico A.4		-	-	2							
	Q021423	Tornillo alomado M.4x20		-	-	2							
23	P506004	Soporte detector		1	1	-							
	Q242020	Arandela abanico A.4		2	2	-							
	Q021423	Tornillo alomado M.4x20		2	2	-							
24	P503027	Cableado detector		1	1	1							
	Q242010	Arandela abanico A.3		1	1	1							
	Q032011	Tornillo alomado M.3x10		1	1	1							
25	P503009	Convertidor V/F Liar		1	1	1							
26	P503012	Amarre convertidor		4	4	4							
	Q242030	Arandela abanico A.5		8	8	8							
	Q152051	Tornillo exagonal M.5x6		8	8	8							
27	X723014	Pasamuros Ø30		1	1	1							
28	Q151323	Tornillo broca Ø4,8x16		9	9	9							
29	P500304	Soporte electroválvulas		1	1	-							
29	P520304	Soporte electroválvulas		-	-	1							
30	R023013	Prensaestopas		1	1	1							
31	P453025	Borna fases (gris)		3	3	3							
	Z263302	Borna neutro (azul)		1	1	1							
	P453026	Borna tierra (verde-amarillo)		1	1	1							
	Z263303	Tope final		1	1	1							
	Z103083	Guía contactor L=73		1	1	1							
32	P453020	Sujeción termostato		1	1	1							
	Q021331	Tornillo alomado M.5x10		2	2	2							

MOD.		LAVADORAS		ZONA		PARTE FUNCIONAL ELECTRICA					PLANO		C-725
ITEM	CODIGO	DENOMINACION	TEXTO	LAC-7	LAC-10	LAC-14							NOTAS
	Q221342	Remache exagonal M.5		2	2	2							
33	P433018	Termostato		1	1	1							
	Q032021	Tornillo alomado M.4x10		2	2	2							
34	Z263303	Tope final		1	1	1							
35	R073005	Borna portafusible		1	1	1							
s/n	P184011	Cartucho fusible 4A.		1	1	1							
36	P443080	Bloque contacto auxiliar		1	1	1							
37	X183011	Contactador calentamiento		1	1	1							
38	P433030	Contactador centrifugado		1	1	1							
39	P433030	Contactador lavado		1	1	1							
40	Z123019	Guía contactor L=175		1	1	1							
41	R243010	Conector hembra 12 vías		1	1	1							
42	R433013	Selección estándar		1	1	1							
43	Z703048	Pasamuros bulbo termostato		1	1	1							
44	P103012	Resistencia 2000W., 230V.		3	-	-							
44	P143002	Resistencia 3000W., 230V.		-	3	-							
44	P183002	Resistencia 4000W., 230V.		-	-	3							
45	P443060	Tapón		1	1	1							
46	N503017	Soporte termostato		1	1	1							

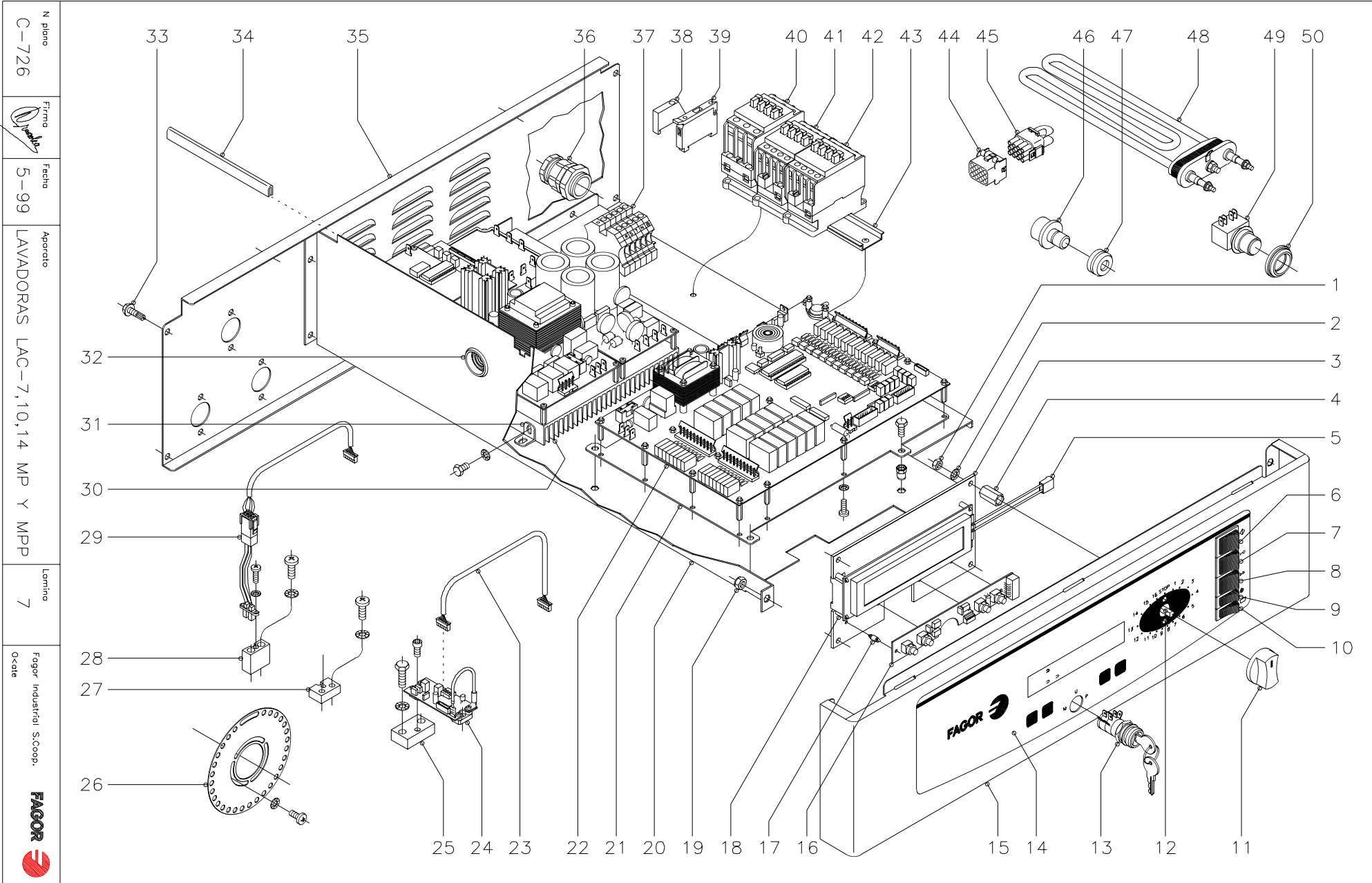



N plano
 C-726
 Firma
 Fecha
 5-99
 Aparato
 LAVADORAS LAC-7,10,14 MP Y MPP
 Laminado
 7
 Fagor Industrial S.Coop.
 Ocala
FAGOR

MOD.		LAVADORAS		ZONA		PARTE FUNCIONAL ELECTRICA				PLANO		C-726	
ITEM	CODIGO	DENOMINACION	TEXTO	LAC-7 MP	LAC-10 MP	LAC-14 MP	LAC-7 MPP	LAC-10 MPP	LAC-14 MPP				NOTAS
1	Q162020	Tuerca exagonal M.4		4	4	4	4	4	4				
2	Q242020	Arandela abanico A.4		4	4	4	4	4	4				
3	P503052	Soporte display y teclado		1	1	1	1	1	1				
4	P503034	Casquillo		4	4	4	4	4	4				
5	P503050	Display completo		1	1	1	1	1	1				
6	Z213033	Pulsador marcha		1	1	1	1	1	1				
7	P503005	Pulsador verde puerta		1	1	1	1	1	1				
8	P503006	Pulsador blanco avance		1	1	1	1	1	1				
9	P503026	Interruptor ambar sin centrifugado		1	1	1	1	1	1				
10	P503026	Interruptor ambar (flot)		1	1	1	1	1	1				
11	R663062	Botón de mando completo		1	1	1	1	1	1				
12	P503029	Selector de programa		1	1	1	1	1	1				
	Q151320	Tornillo alomado M.4x6		2	2	2	2	2	2				
	Q242020	Arandela abanico A.4		2	2	2	2	2	2				
	P503037	Sujeción selector de programa		1	1	1	1	1	1				
	Q222012	Tuerca exagonal autobloq. M.5		2	2	2	2	2	2				
13	P503032	Interruptor a llave		-	-	-	1	1	1				
14	P500323	Embellecedor portamandos		1	1	1	-	-	-				
14	P500325	Embellecedor portamandos		-	-	-	1	1	1				
15	P500320	Portamandos		1	1	-	1	1	-				
15	P520311	Portamandos		-	-	1	-	-	1				
16	P503011	Teclado programador		-	-	-	1	1	1				
17	P503045	Separador teclado		-	-	-	4	4	4				
18	P503043	Separador display		4	4	4	4	4	4				
19	Q222012	Tuerca exagonal autobloq. M.6		3	3	3	3	3	3				
20	P503003	Soporte cuadro eléctrico		1	-	-	1	-	-				
20	P513001	Soporte cuadro eléctrico		-	1	-	-	1	-				
20	P523001	Soporte cuadro eléctrico		-	-	1	-	-	1				
21	P503051	Suplemento cuadro eléctrico		1	1	1	1	1	1				

MOD.		LAVADORAS		ZONA		PARTE FUNCIONAL ELECTRICA				PLANO		C-726	
ITEM	CODIGO	DENOMINACION	TEXTO	LAC-7 MP	LAC-10 MP	LAC-14 MP	LAC-7 MPP	LAC-10 MPP	LAC-14 MPP				NOTAS
	Q012031	Tornillo exagonal M.5x10		4	4	4	4	4	4				
	Q221342	Remache exagonal M.5		4	4	4	4	4	4				
22	P503010	Programador electrónico		1	1	1	1	1	1				
	Q152015	Tornillo alomado M.3x6		12	12	12	12	12	12				
	Q242010	Arandela abanico A.3		12	12	12	12	12	12				
23	P503028	Cableado sensor		2	2	2	2	2	2				
24	P533016	Sensor galga liar		2	2	2	2	2	2				
	Q122031	Tornillo allen M.5x10		4	4	4	4	4	4				
25	P526006	Calzo sensor		-	-	1	-	-	1				
	Q242040	Arandela abanico A.6		-	-	2	-	-	2				
	Q012043	Tornillo exagonal M.6x20		-	-	2	-	-	2				
26	P506006	Disco detector		1	1	1	1	1	1				
	Q242020	Arandela abanico A.4		3	3	3	3	3	3				
	Q153021	Tornillo alomado M.4x10		3	3	3	3	3	3				
27	P526007	Soporte detector		-	-	1	-	-	1				
	Q242020	Arandela abanico A.4		-	-	2	-	-	2				
	Q021423	Tornillo alomado M.4x20		-	-	2	-	-	2				
28	P506004	Soporte detector		1	1	-	1	1	-				
	Q242020	Arandela abanico A.4		2	2	-	2	2	-				
	Q021423	Tornillo alomado M.4x20		2	2	-	2	2	-				
29	P503027	Cableado detector		1	1	1	1	1	1				
	Q242010	Arandela abanico A.3		1	1	1	1	1	1				
	Q032011	Tornillo alomado M.3x10		1	1	1	1	1	1				
30	P503009	Convertidor V/F Liar		1	1	1	1	1	1				
31	P503012	Amarre convertidor		4	4	4	4	4	4				
	Q242030	Arandela abanico A.5		8	8	8	8	8	8				
	Q152051	Tornillo exagonal M.5x6		8	8	8	8	8	8				
32	X723014	Pasamuros Ø30		1	1	1	1	1	1				
33	Q151323	Tornillo broca Ø4,8x16		9	9	9	9	9	9				

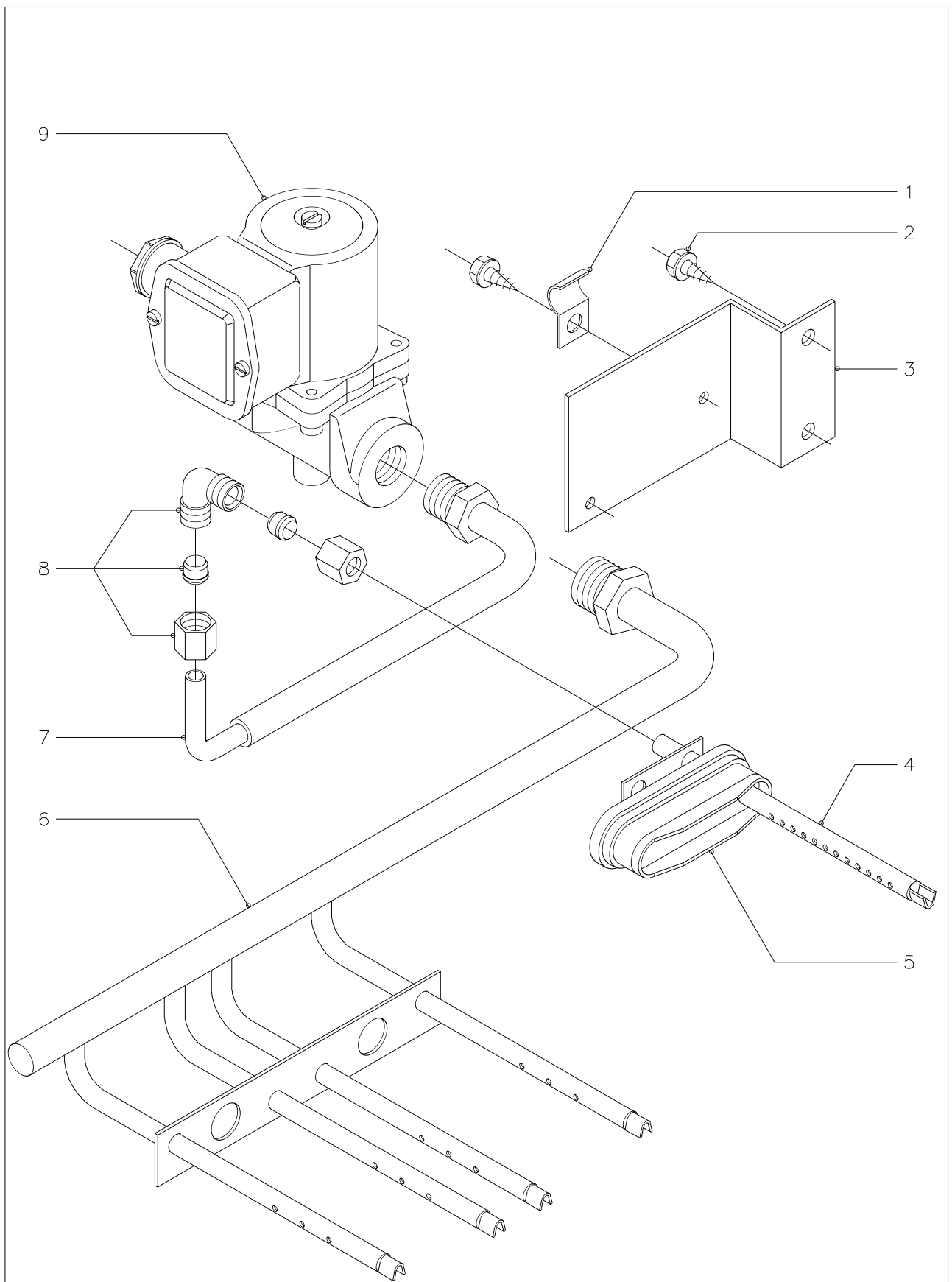
MOD.		LAVADORAS		ZONA		PARTE FUNCIONAL ELECTRICA				PLANO		C-726	
ITEM	CODIGO	DENOMINACION	TEXTO	LAC-7 MP	LAC-10 MP	LAC-14 MP	LAC-7 MPP	LAC-10 MPP	LAC-14 MPP				NOTAS
34	3673700	Perfil goma gris en "U" 12x6x700		1	1	1	1	1	1				
35	P500304	Soporte electroválvulas		1	1	-	1	1	-				
35	P520304	Soporte electroválvulas		-	-	1	-	-	1				
36	R023013	Prensaestopas		1	1	1	1	1	1				
37	P453025	Borne fase gris		3	3	3	3	3	3				
	Z263302	Borne neutro azul		1	1	1	1	1	1				
	P453026	Borne tierra verde amarillo		1	1	1	1	1	1				
	Z263303	Tope final		1	1	1	1	1	1				
	Z103083	Guía contactor L=73		1	1	1	1	1	1				
38	Z263303	Tope final		1	1	1	1	1	1				
39	R073005	Borna portafusible		1	1	1	1	1	1				
s/n	P184011	Cartucho fusible 4A.		1	1	1	1	1	1				
40	X183011	Contacto calentamiento		1	1	1	1	1	1				
41	P433030	Contacto centrifugado		1	1	1	1	1	1				
42	P433030	Contacto lavado		1	1	1	1	1	1				
43	Z123019	Guía contactor L=175		1	1	1	1	1	1				
44	R243010	Conector hembra 12 vías		1	1	1	1	1	1				
45	R433013	Selector estándar		1	1	1	1	1	1				
46	P503024	Tapón		1	1	1	1	1	1				
47	Z703048	Pasamuros bulbo termostato		1	1	1	1	1	1				
48	P103012	Resistencia 2000W., 230V.		3	-	-	3	-	-				
48	P143002	Resistencia 3000W., 230V.		-	3	-	-	3	-				
48	P183002	Resistencia 4000W., 230V.		-	-	3	-	-	3				
49	P503025	Sonda temperatura cuba		1	1	1	1	1	1				
50	N503017	Soporte termostato		1	1	1	1	1	1				



N plano C-727	Firma 	Fecha 5-99	Aparato LAVADORAS : 7, 10, 14	Lamina 8	Fagor Industrial S.Coop. FAGOR  0<ate
------------------	--	---------------	----------------------------------	-------------	--

MOD.		LAVADORAS	ZONA	VERSION VAPOR			PLANO	C-727					
ITEM	CODIGO	DENOMINACION	TEXTO	L-7	L-10	L-14							NOTAS
		SE ELIMINA											
	P503018	Cableado a resistencias		1	1	1							
	P103012	Resistencia 2000W., 230V.		3	-	-							
	P143002	Resistencia 3000W., 230V.		-	3	-							
	P183002	Resistencia 4000W. 230V.		-	-	3							
		SE INTRODUCE											
1	Q901305	Grapa spit para Ø12		1	1	-							
1	Q901400	Grapa spit para Ø14		-	-	1							
2	Q151337	Tornillo taptite M.5x10		3	3	3							
3	P445022	Soporte conducto vapor		1	1	-							
3	P455017	Soporte conducto vapor		-	-	1							
4	P445023	Inyector de vapor completo		1	1	-							
5	P445011	Cierre completo		3	3	3							
6	P455004	Inyector de vapor completo		-	-	1							
7	P445014	Conducto entrada vapor completo		1	1	-							
8	P445013	Racord en codo biconos y tuercas		1	1	-							
9	P266125	Electrovalvula vapor 3/8"		1	1	-							
9	P455003	Electroválvula vapor 1/2"		-	-	1							
s/n	P503056	Cableado electroválvula vapor		1	1	1							

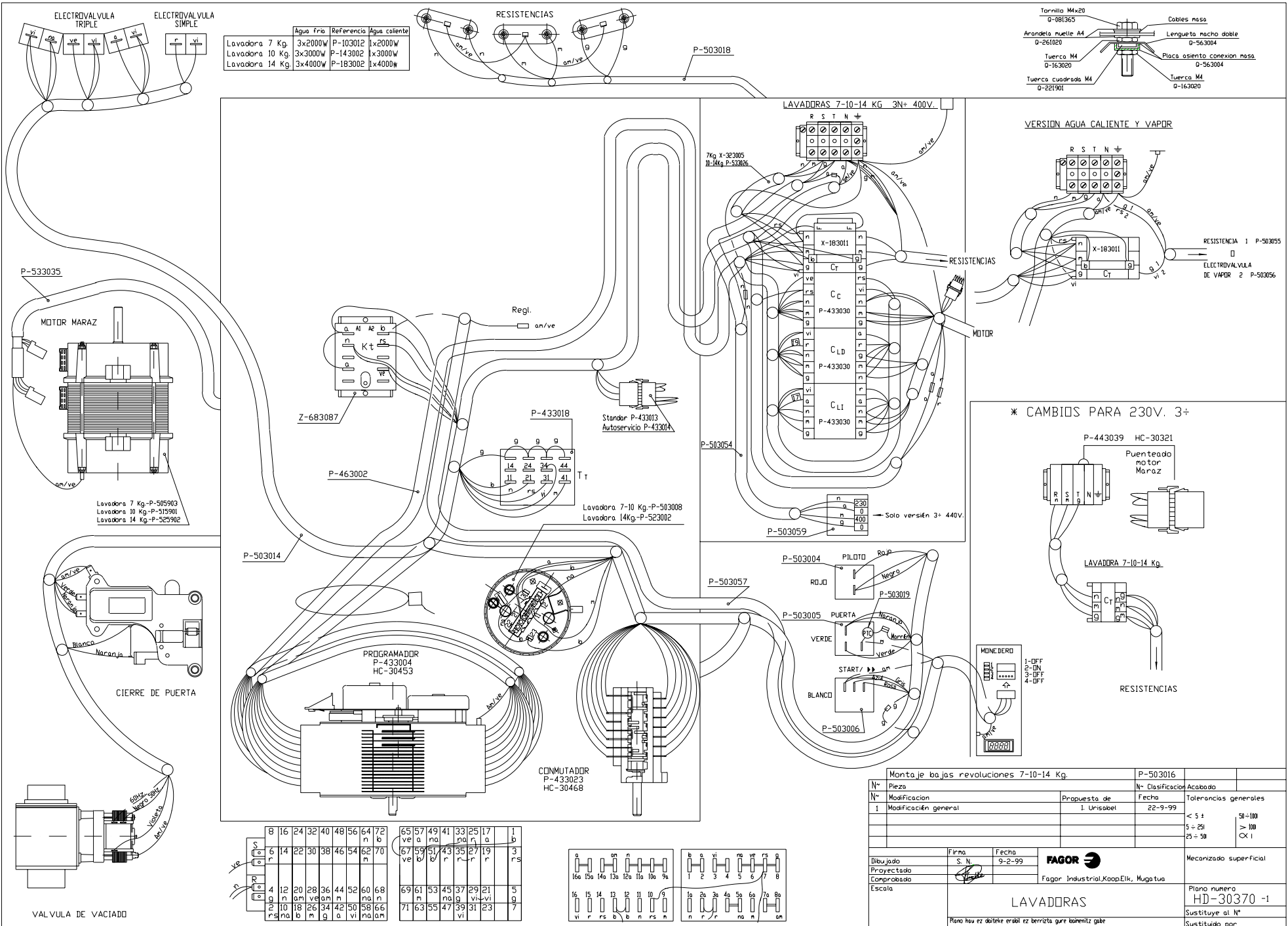

Montaje bajas revoluciones 7-10-14 Kg.		P-503016		
Nº Pieza	Clasificación	Fecha	Acabado	
1	Modificación general	1. Unisabel	22-9-99	Tolerancias generales
				< 5 ±
				5 - 25
				25 - 50
				> 100
				∞ I
Dibujado	Firma	Fecha	 Fagor Industrial, Koop, Elk, Mugatu	Mecanizado superficial
Proyectado	S. N.	9-2-99		
Comprobado				
Escala				Plano número
				HD-30370 -1
				Sustituye al Nº
				Sustituido por

Plano hau ez daiteke erabili ez berrieta gure baimeniz gabe

COMUTADOR SELECTOR DE PROGRAMAS

	1	2	3	4	5	6	7	8	9	10	11	12	13	14	15	16	
STOP	X	X	X	X	X	X	X	X	X	X	X	X	X	X	X	X	X
N40	X	X	X	X	X	X	X	X	X	X	X	X	X	X	X	X	X
N60	X	X	X	X	X	X	X	X	X	X	X	X	X	X	X	X	X
N90	X	X	X	X	X	X	X	X	X	X	X	X	X	X	X	X	X
PP90	X	X	X	X	X	X	X	X	X	X	X	X	X	X	X	X	X
PP60	X	X	X	X	X	X	X	X	X	X	X	X	X	X	X	X	X
DEL	X	X	X	X	X	X	X	X	X	X	X	X	X	X	X	X	X
LN	X	X	X	X	X	X	X	X	X	X	X	X	X	X	X	X	X

LC-7. LC-10. LC-14

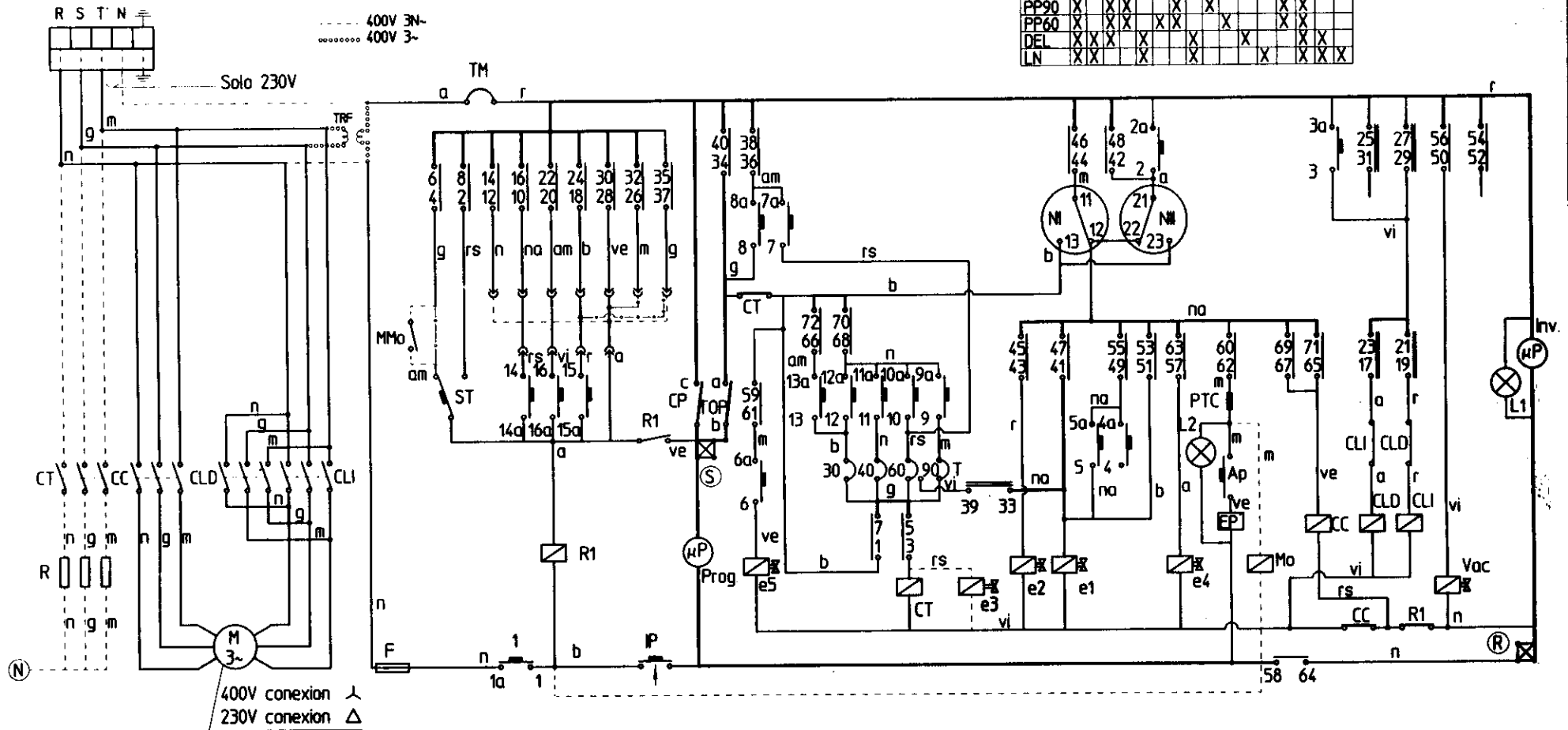

CONEXIONES

- STANDARD
- AUTOSERVICIO

CONTACTOS PROGRAMADOR

- Leva principal
- Inversores

CODIGO DE COLORES:

- r - rojo
- m - marron
- g - gris
- n - negro
- b - blanco
- vi - violeta
- am - amarillo
- na - naranja
- rs - rosa
- ve - verde
- am/ve - amarillo verde

PILOTOS

- L1- Marcha
- L2- Parada/Apertura

PULSADORES

- ST- Marcha/Avan rapido
- Ap- Apertura puerta

CONTACTORES

- CT- Contactor Calentamiento
- CLD- Contactor Lavado dcha
- CLI- Contactor Lavado izda
- CC- Contactor Centrifugado
- R1- Rele avance rapido
- Mo- Monedero
- MMA- Micro monedero

MOTOR PROGRAMADOR

- μP- Levas principales
- μP- Levas inversion

PRESOSTATOS

- NI- Nivel bajo
- NI- Nivel alto

ELECTROVALVULAS

- e1- Prelavado y aclarados
- e2- Lavado
- e3- Vapor (Solo esa version)
- e4- Suavizante
- e5- Leja

VARIOS

- T- Termostato 30, 40, 60, 90°C
- Ip- Micro puerta
- Tm- Termico motor
- F- Fusible
- Ep- Electroiman de puerta
- Vac- Valvula de Vaciado
- M- Motor
- R- Resistencia calentamiento
- TRF- Transformador (solo version 400V 3~)

Esquema teorico adhesivo (Bajas revoluciones)

Nº	Pieza	P-433031	
Nº	Modificacion	Nº Clasificacion	Acabado
	Propuesta de	Fecha	Tolerancias generales
			< 5 :
			5-25 :
			> 25-50 :
			50-100 :
			> 100 :
			∞ :
Dibujado	Firma	Fecha	Mecanizado superficial
Proyectado	S. N.	13-1-99	
Comprobado			
Escala			
FAGOR			
Fagor Industrial, Koop Elk, Mugatua			
LAVADORAS			Plano numero
Plano hau ez daiteke erabili ez berrizta gure baimen zigabete.			HC-30690
Sustituye a N°			
Sustituido por			

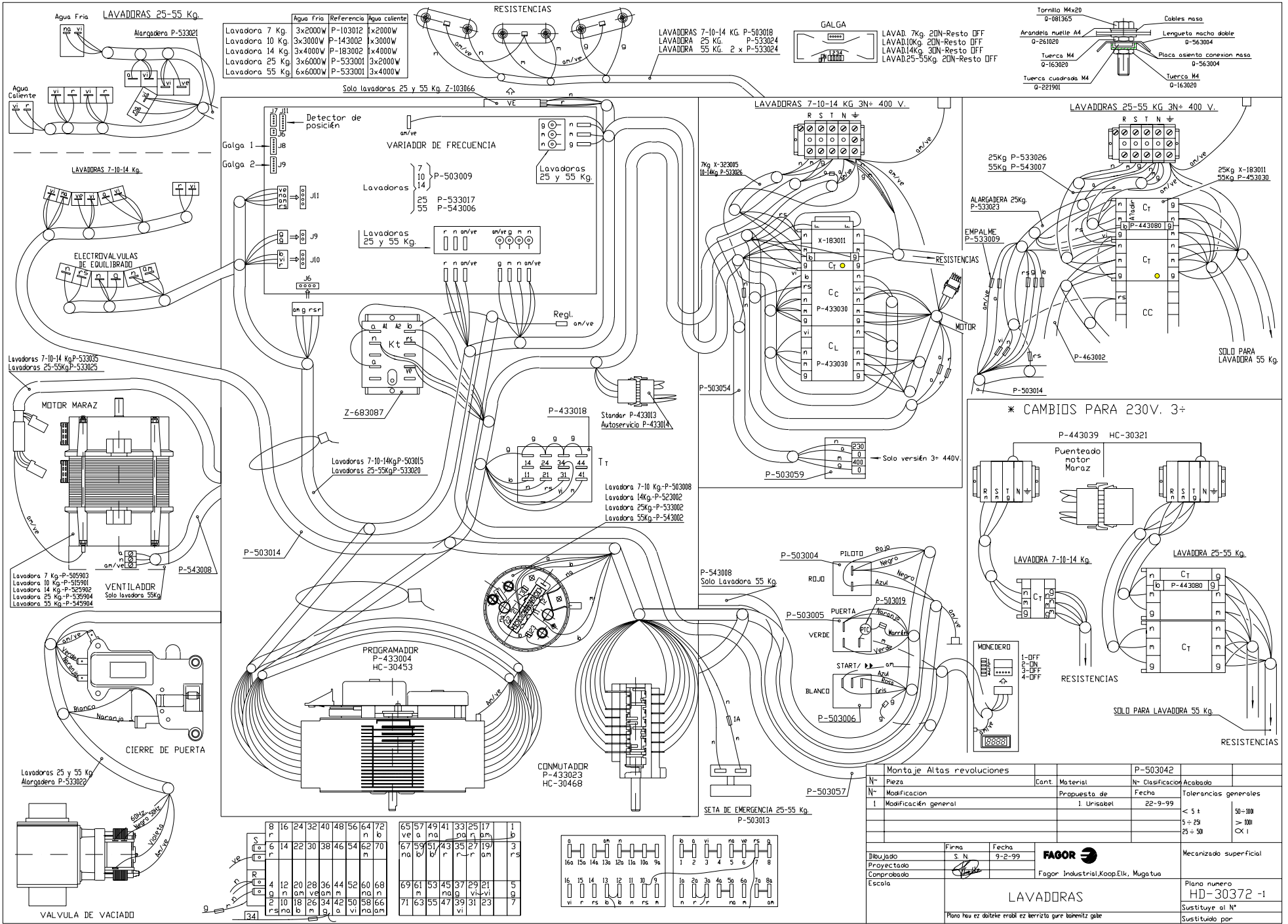

Agua Fria	Referencia	Agua caliente
Lavadora 7 Kg.	3x200W P-103012	1x200W
Lavadora 10 Kg.	3x3000W P-143002	1x3000W
Lavadora 14 Kg.	3x4000W P-183002	1x4000W
Lavadora 25 Kg.	3x6000W P-533002	3x200W
Lavadora 55 Kg.	6x6000W P-533001	3x4000W

LAVADORAS 7-10-14 KG P-503018
 LAVADORAS 25 KG P-533024
 LAVADORA 55 KG. 2 x P-533024



LAVAD. 7kg. 20N-Resto OFF
 LAVAB. 10kg. 20N-Resto OFF
 LAVAB. 14kg. 30N-Resto OFF
 LAVAB. 25-55kg. 20N-Resto OFF

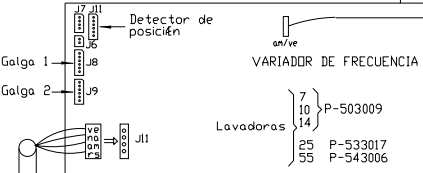
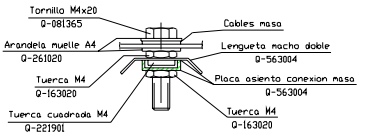

LAVADORAS 7-10-14 KG 3N+ 400 V.

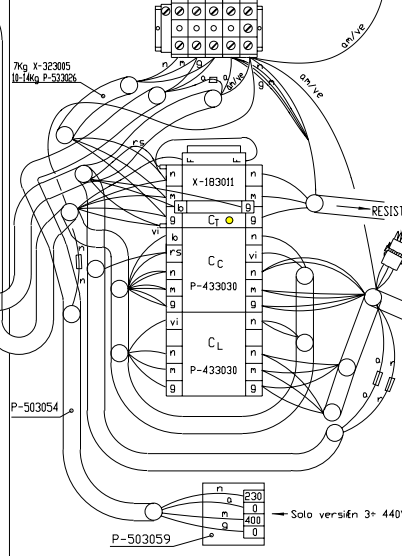

LAVADORAS 25-55 KG 3N+ 400 V.

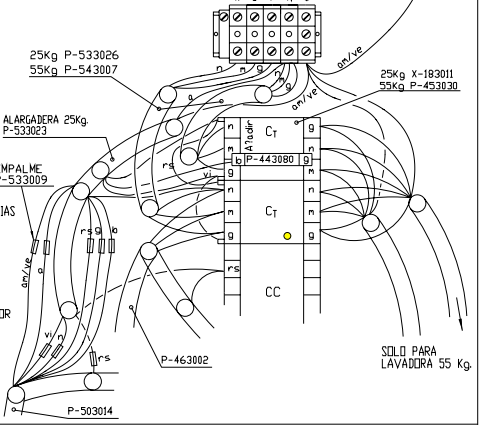

* CAMBIOS PARA 230V. 3+

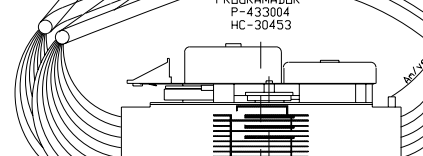
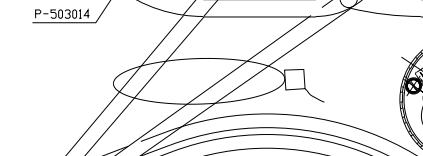
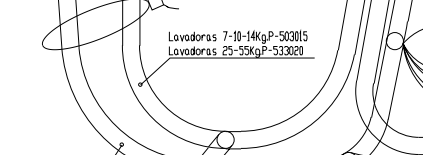
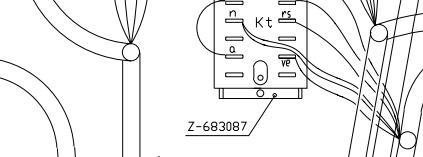
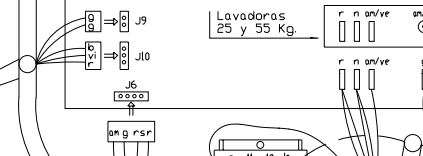
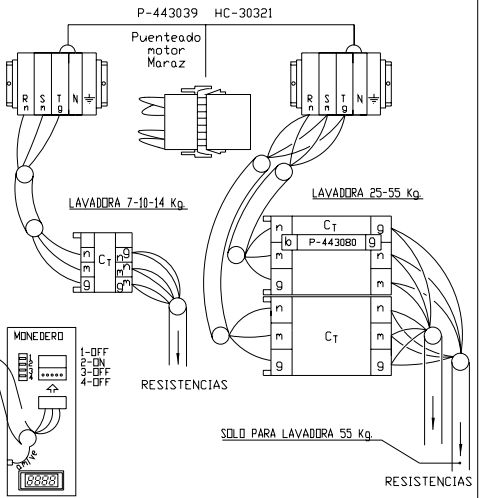

8	16	24	32	40	48	56	64	72	65	57	49	41	33	25	17	1
n	n	n	n	n	n	n	n	n	ve	o	no	la	o	no	la	o
6	14	22	30	38	46	54	62	70	67	59	51	43	35	27	19	3
n	n	n	n	n	n	n	n	n	no	la	o	no	la	o	no	la
4	12	20	28	36	44	52	60	68	69	61	53	45	37	29	21	5
g	g	g	g	g	g	g	g	g	no	g	no	g	no	g	no	g
2	10	18	26	34	42	50	58	66	71	63	55	47	39	31	23	7
n	n	n	n	n	n	n	n	n	no	la	o	no	la	o	no	la

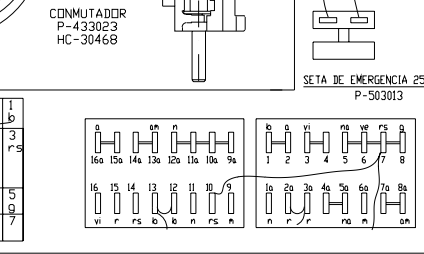

Montaje Altas revoluciones			P-503042	
N°	Pieza	Cont.	Material	N° Clasificación
N°	Modificación		Propuesta de	Fecha
I	Modificación general		1 Unisabel	22-9-99
				Tolerancias generales
				< 5 ±
				5 - 25
				25 - 50
				50 - 100
				> 100
				OX 1
Dibujado				Mecanizado superficial
Proyectado				
Comprobado				
Escala				
Firma				
Fecha				
9-2-99				
FAGOR				
Fagor Industrial, Koop Elk, Muga-tua				
LAVADORAS				Plano numero
				HD-30372-1
				Sustituye al N°
				Sustituido por

LAC-7, LAC-10, LAC-14, LAC-25, LAC-55

COMUTADOR SELECTOR DE PROGRAMAS

	1	2	3	4	5	6	7	8	9	10	11	12	13	14	15	16
STOP		X	X	X	X	X	X	X			X	X	X			
N40	X								X	X	X					
N60	X	X	X	X	X	X	X	X	X							
N90	X	X	X	X	X	X	X	X	X	X	X	X	X	X	X	X
PP90	X	X	X	X	X	X	X	X	X	X	X	X	X	X	X	X
PF60	X	X	X	X	X	X	X	X	X	X	X	X	X	X	X	X
DEL	X	X	X	X	X	X	X	X	X	X	X	X	X	X	X	X
LN	X	X	X	X	X	X	X	X	X	X	X	X	X	X	X	X

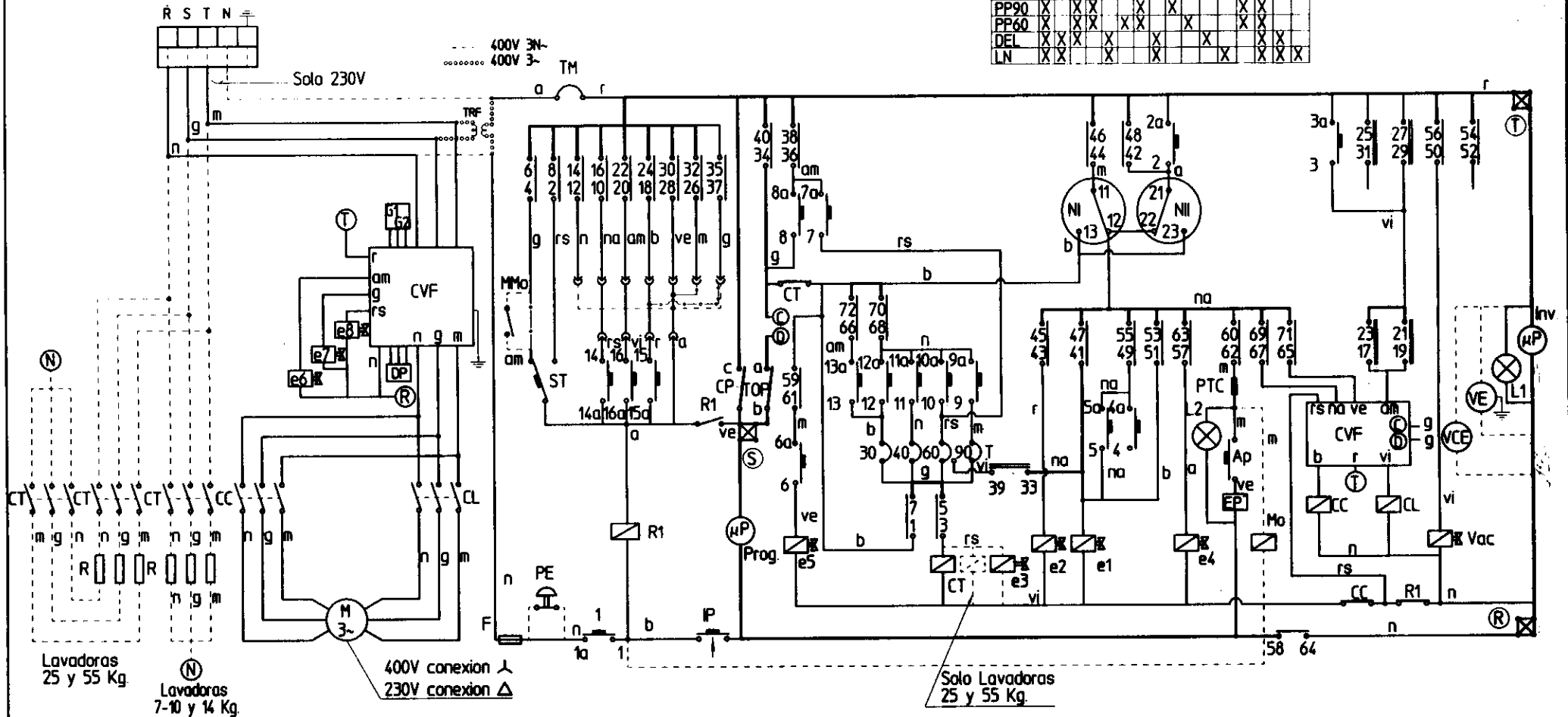

CONEXIONES

- STANDARD
- AUTOSERVICIO
- CONTACTOS PROGRAMADOR
- Leva principal
- Inversores

CODIGO DE COLORES

- r = rojo
- m = marron
- g = gris
- n = negro
- b = blanco
- vi = violeta
- am = amarillo
- na = naranja
- rs = rosa
- ve = verde
- am/ve = amarillo verde

PILOTOS

- L1- Marcha
- L2- Parada/Apertura

PULSADORES

- ST- Marcha/Avan rapido
- Ap- Apertura puerta
- PE- Parada de emergencia (solo lavadoras 25 y 55 Kg)

CONTACTORES

- CT- Contactor Calentamiento
- CL- Contactor Lavado
- CC- Contactor Centrifugado
- R1- Rele avance rapido
- Mo- Monedero
- MMo- Micro monedero

MOTOR PROGRAMADOR

- μ P- Levas principales
- μ P- Levas inversión

PRESOSTATOS

- N- Nivel bajo
- NI- Nivel alto

ELECTROVALVULAS

- e1- Prelavado y aclarados
- e2- Lavado
- e3- Vapor (Solo esa versión)
- e4- Suavizante
- e5- Lejía
- e6, e7, e8- Electrovalvulas de equilibrado

VARIOS

- T- Termostato 30, 40, 60, 90°C
- lp- Micro puerta
- Tm- Térmico motor
- F- Fusible
- Ep- Electroión de puerta
- Vac- Válvula de Vacío
- M- Motor
- VE- Ventilador motor (solo lavadoras 55 Kg)
- R- Resistencia calentamiento
- TRF- Transformador (solo versión 400V.3~)
- CVF- Convertidor tensión/frecuencia
- G1 G2- Sensores galga
- DP- Detector de posición
- VCE- Ventilador de CVF (solo lavad. 25 y 55 Kg)

Esquema teorico adhesivo (Altas revoluciones)

Nº	Pieza	P-503017	
Nº	Modificación	Nº Clasificación	Acabado
	Propuesta de	Fecha	Tolerancias generales
			< 5 : 50-100: 5-25: > 100: 25-50: X!
			Mecanizada superficial
			Plano numero
			HC-30635
			Sustituye al Nº
			Sustituido por

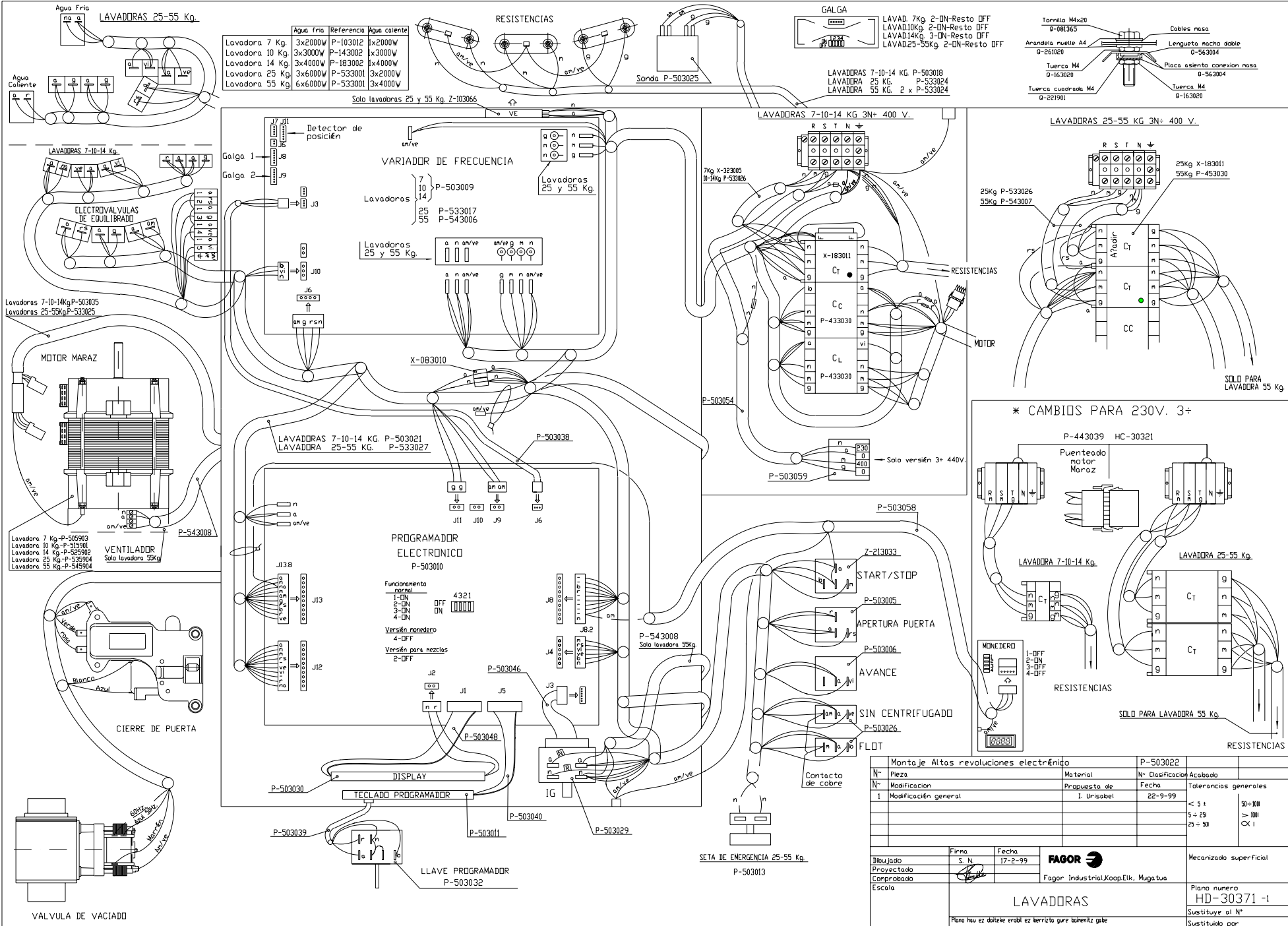

LAC-7MP, LAC-10MP, LAC-14MP, LAC-25MP, LAC-55MP
 LAC-7MPP, LAC-10MPP, LAC-14MPP, LAC-25MPP, LAC-55MPP

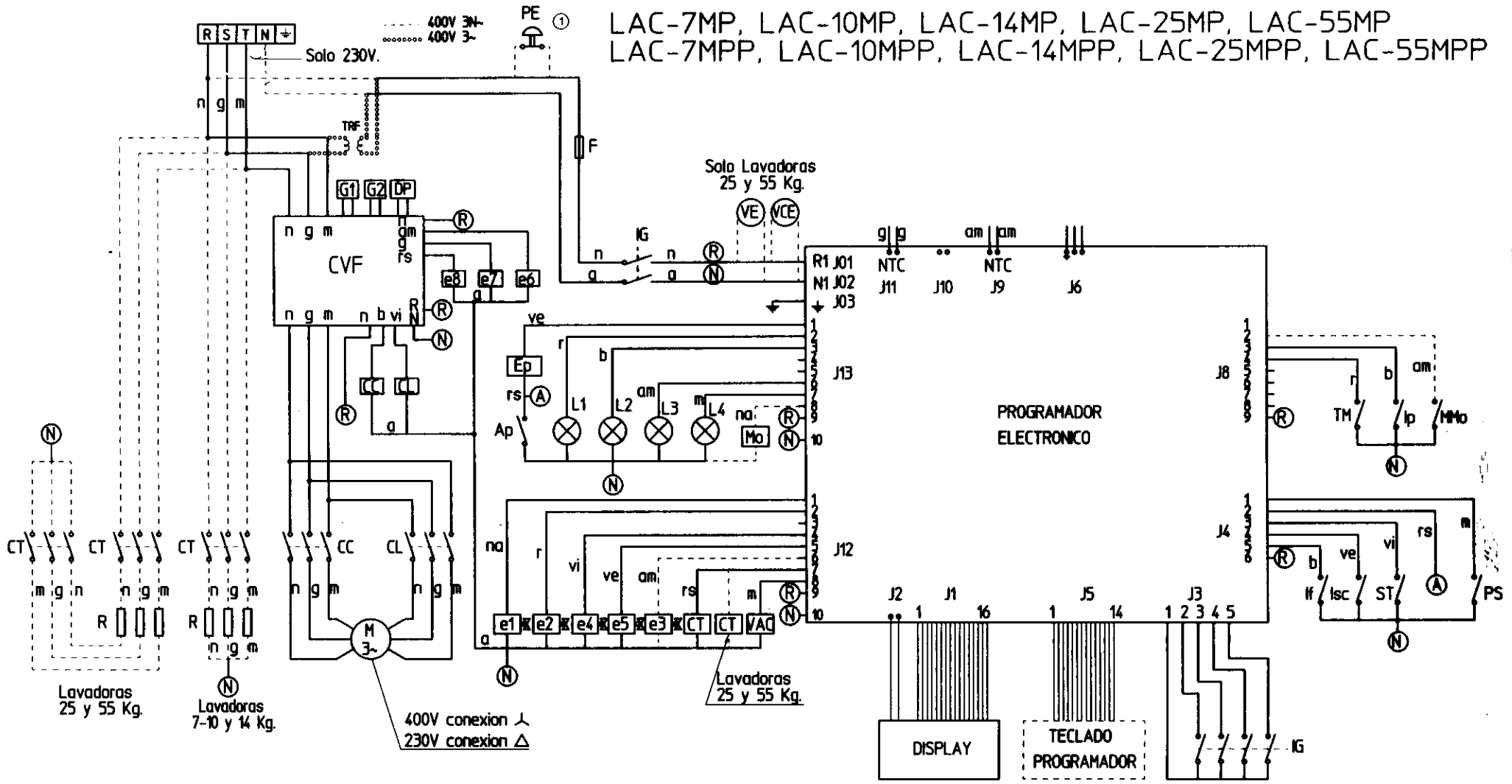

CODIGO DE COLORES:

- r = rojo
- m = marron
- g = gris
- n = negro
- b = blanco
- vi = violeta
- am = amarillo
- na = naranja
- rs = rosa
- ve = verde
- am/ve = amarillo verde

PULSADORES

- ST- Avance rapido
- Ap- Apertura puerta
- PS- Pulsador start-stop
- PE- Parada de emergencia (solo lavadoras 25 y 55 Kg)
- If- interruptor de flot
- lsc- interruptor sin centrif.
- MMa- Micro monedero (autoservicio)

CONTACTORES

- CT- Contactor Calentamiento
 - CL- Contactor Lavado
 - CC- Contactor Centrifugado
 - Ma- Monedero (autoservicio)
- ELECTROVALVULAS**
- e1- Prelavado y aclarados
 - e2- Lavado
 - e3- Vapor (solo esa versión)
 - e4- Suavizante
 - e5- Leja
 - e6, e7, e8- Electroválvulas de equilibrio
- PILOTOS**
- L1- Apertura puerta
 - L2- Start-Stop
 - L3- Sin centrifugado
 - L4- Flot

VARIOS

- IG- Interruptor general (selector)
- lp- Micro puerta
- Tm- Termico motor
- F- Fusible
- Ep- Electroiman de puerta
- Vac- Valvula de Vaciado
- M- Motor
- VE- Ventilador motor (solo lavadoras 55 Kg.)
- R- Resistencia calentamiento
- CVF- Convertidor tensión/frecuencia
- G1 G2- Sensores galga
- DP- Detector de posición
- TRF- Transformador (solo versión 400V.3-)
- VCE- Ventilador de CVF (solo lavadoras 25 y 55 Kg)

Esquema teorico adhesivo			P-503031		
Nº	Pieza	Cant.	Material	Nº Clasificación	Acabado
Nº	Modificación		Propuesta de	Fecha	Tolerancias generales
①	Modificar de lugar PE		L. Uribeal	7-5-99	< 5% 5-25% 25-50%
Firma			Fecha	Mecanizado superficial	
Dibujado		S. N.	9-2-99	Plano numero	
Proyectado				HC-30659 -1	
Comprobado				Sustituye al Nº	
Escala				Sustituido por	
LAVADORAS					
Plano hau ez daiteke erabili ez berizko gure baimenaz...					