

---

DESPIECE TECNICO

---

**Lavadoras**

**Washing machines**

**SERIE "EVOLUTION TECHNOLOGY"**

**Modelos:**

**LA-10 MPP**

*Abril 2007 April*



**Fagor Industrial**



Fagor Industrial

**LAVADORA MODELO LA-10 MPP**



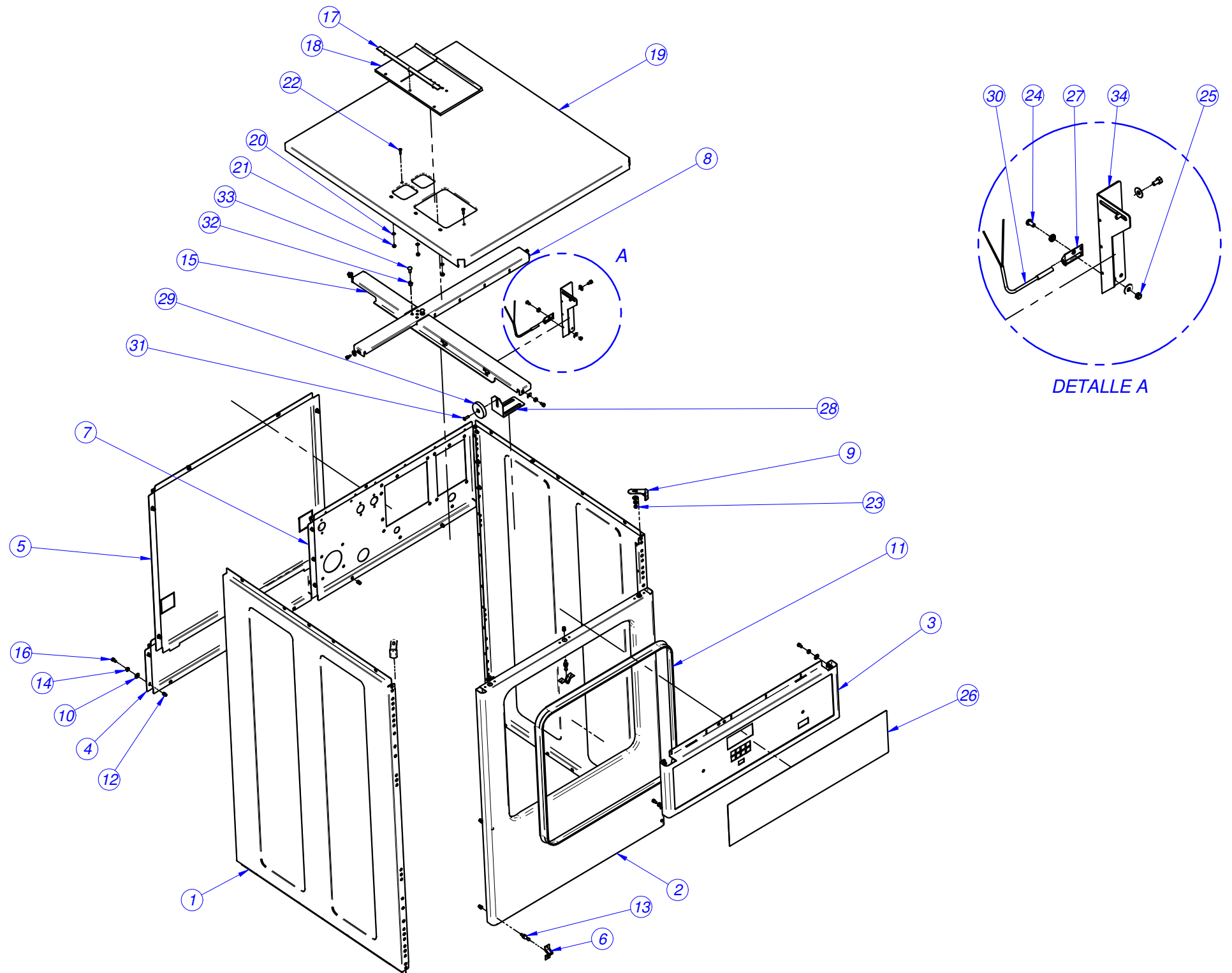

MOD.	LAVADORA LA-10 MPP		ZONA	MUEBLE	
Nº	CODIGO	DENOMINACION	Cant.		
1	P610339000	PANEL LATERAL 10	2		
2	P610302000	PANEL FRONTAL 8	1		
3	P610318000	PORTA MANDOS COMP. 8 MPP	1		
4	P610306000	PANEL POSTERIOR DESAGUE 8	1		
5	P610326000	PANEL POSTERIOR 8 V2	1		
6	X010503000	CIERRE MUELLE FREI.700	7		
7	P610325000	PANEL POSTERIOR TOMAS 8 V2	1		
8	P610335000	TRAVESANO PARALELO 8 V2	1		
9	P620316000	CANTONERA ENCIMERA	2		
10	Q302022000	ARANDELA 16X6X1.2 A.304	31		
11	P610314000	CORTINA LF-8	1		
12	Q221342000	REMACHE EXAGONAL M5	32		
13	X012612000	PITON CIERRE	7		
14	Q242030000	ARAND.ABAN. A5 A.304	26		
15	P610340000	TRAVESANO LONGITUDINAL 10	1		
16	Q012031000	TORN.EXA. M5X10 A.304	28		
17	P440705000	SOPOR.TAPA CUB. COMPLETA	1		
18	P440704000	TAPA CUBETA 1002436	1		
19	P610341000	ENCIMERA COMPLETA 10	1		
20	Q232030000	ARANDELA A5	3		
21	Q162030000	TUER.EXA. M5	3		
22	Q042022000	TORN.AVE.M4X15	2		
23	Q221308000	TUE.EX.AUT.M5 H.ZINCADA	2		
24	Q032031000	TORN.ALOM.M5X10	1		
25	Q222030000	TUER.AUTOB.M5	1		
26	P610310000	ADHESIVO PORTAMANDOS 8 MPP	1		
27	Z203010000	AMARRE INTERRUPTOR MAGNETICO	1		
28	P620219000	SOPORTE IMANES	1		
29	P620337000	IMAN DESEQUILIBRIO DIAM. 50	1		
30	Z203009000	INTERRUPTOR MAGNETICO	1		
31	Q042032000	TOR.AVELL.M5X15 A304	1		
32	Q411310000	COLLAR MAXLOK 6.4	2		
33	Q411309000	REMACHE MAXLOK 6.4	2		
34	P610316000	PORTA MICRO DE SEGURIDAD 8	1		

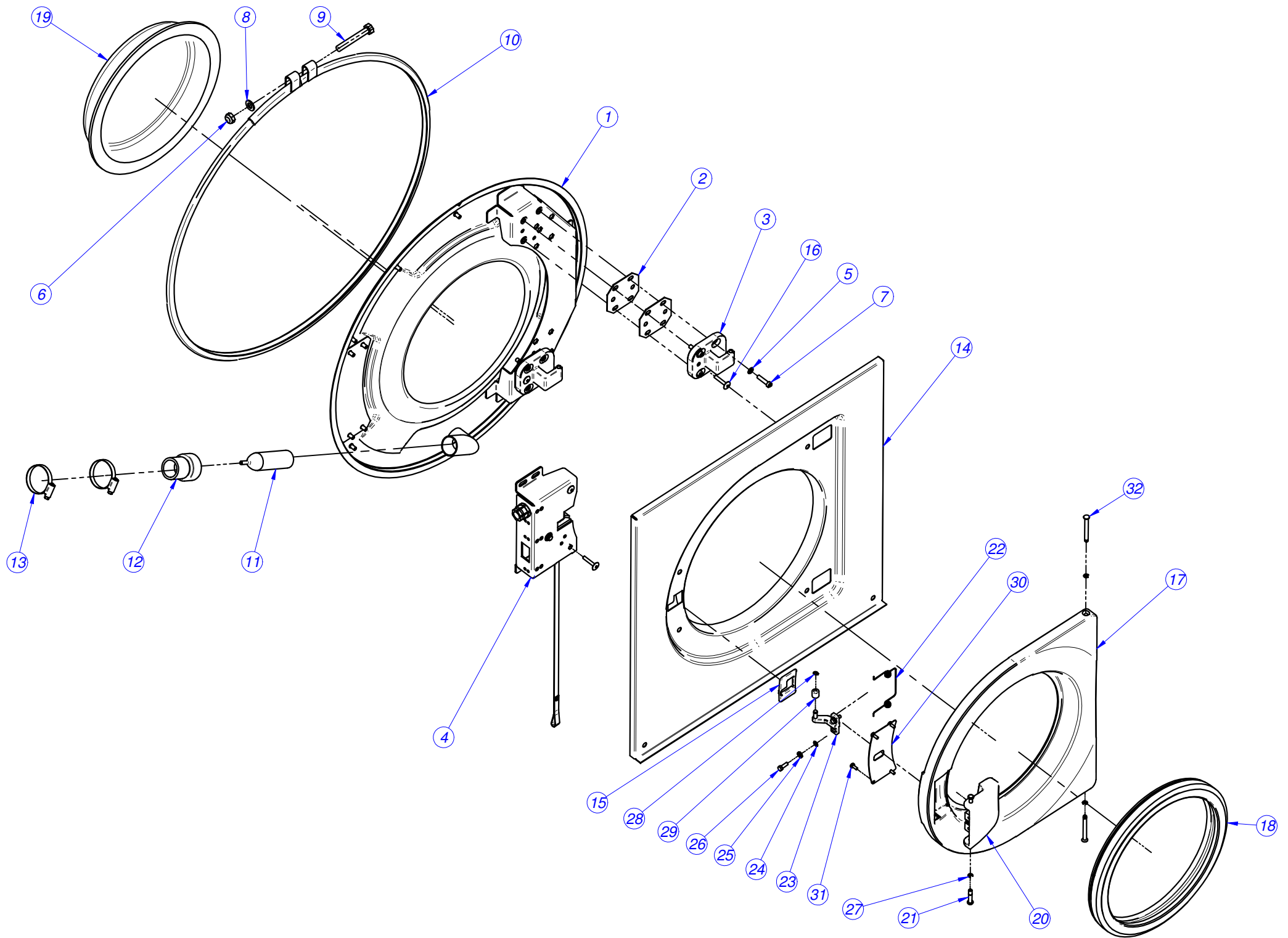

<b>MOD.</b>	<b>LAVADORA LA-10 M</b>		<b>ZONA</b>	<b>FRENTE CUBA</b>	
<b>Nº</b>	<b>CODIGO</b>	<b>DENOMINACION</b>	<b>Cant.</b>		
1	P616112000	FRENTE CUBA COMPLETO 8	1		
2	P620521000	CALZO BISAGRA	4		
3	P620502000	BISAGRA PUERTA	2		
4	P620516000	CIERRE COMPLETO	1		
5	Q232040000	ARANDELA A6	8		
6	Q221306000	TUE.EX.AUT.M10 8.8 ZIN	1		
7	Q122044000	TORN. ALLEN M6x25	8		
8	Q232060000	ARANDELA A10	1		
9	Q011369000	TORN.EX.M10X70 H.ZINCADO	1		
10	P616102000	CIERRE CUBA 8 COMPL.	1		
11	P445002000	CAMARA PRESOSTATO	1		
12	P620711000	CONDUCTO PRESOSTATO	1		
13	Q881306000	ABRAZADERA 32-50L	2		
14	P610501000	FONDO PUERTA 8	1		
15	P620515000	EMBELLECEDOR CIERRE	1		
16	Q152038000	TORN.AMAR.M5X30	4		
17	P610502000	PUERTA 8	1		
18	P440502000	JUNTA PUERTA 1002315	1		
19	P440503000	MIRILLA DE PUERTA	1		
20	P620504000	MANETA PUERTA 8,13,18	1		
21	P620511000	PASADOR CIERRE	2		
22	P620510000	MUELLE CIERRE	1		
23	P620505000	GANCHO REGULABLE CIERRE	1		
24	Q232030000	ARANDELA A5	2		
25	Q242030000	ARAND.ABAN. A5 A.304	2		
26	Q012032000	TORN.EXA. M5X15 A.304	2		
27	Q272020000	ARANDELA SEGURIDAD 4	4		
28	Q302061000	ANILLO SEG. A6 DIN471	1		
29	P610506000	CASQUILLO PUERTA	1		
30	P610504000	TAPA CIERRE 8	1		
31	Q032021000	TORN.ALOM.M4X10	4		
32	P620514000	PASADOR PUERTA	2		

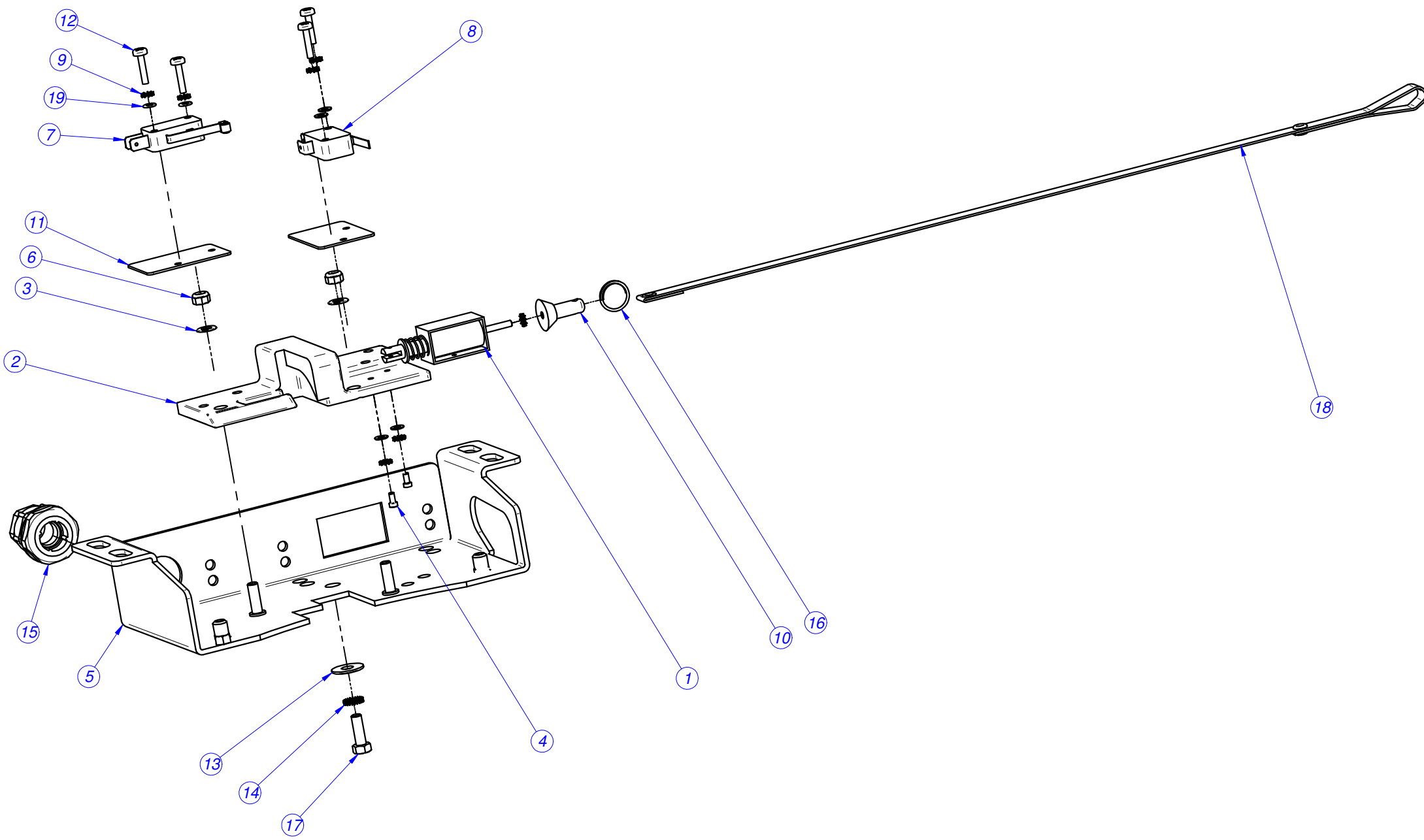

<b>MOD.</b>	<b>LAVADORA LA-10 M</b>		<b>ZONA</b>	<b>CIERRE</b>	
<b>Nº</b>	<b>CODIGO</b>	<b>DENOMINACION</b>	<b>Cant.</b>		
	P620516000	CIERRE COMPLETO	1		
1	P613002000	ELECTROIMAN PUERTA	1		
2	P620522000	BASE CIERRE V2	1		
3	Q232030000	ARANDELA A5	2		
4	Q151396000	TORN. ALLEN M2.5x5	2		
5	P626123000	CALZO CIERRE COMPLETO	1		
6	Q222030000	TUER.AUTOB.M5	2		
7	R010534000	INTERRUPTOR PUERTA	1		
8	P620526000	INTERRUPTOR PUERTA PLANO	1		
9	Q242010000	ARAND.ABAN. A.3 A304	8		
10	P620529000	DESBLOQUEO	1		
11	R010535000	PLACA SEPARADORA	2		
12	Q032012000	TORNILLO ALOMADO M3X15	4		
13	Q302022000	ARANDELA 16X6X1.2 A.304	1		
14	Q242030000	ARAND.ABAN. A5 A.304	1		
15	R073004000	PRENSA ESTOPAS	1		
16	P620525000	ANILLO ELECTROIMAN	1		
17	Q012032000	TORN.EXA. M5X15 A.304	1		
18	P620520000	TIRADOR PUERTA	1		
19	Q232010000	ARANDELA PLANA A3,DIN125	6		
20	P623010000	CABLEADO PUERTA	1		



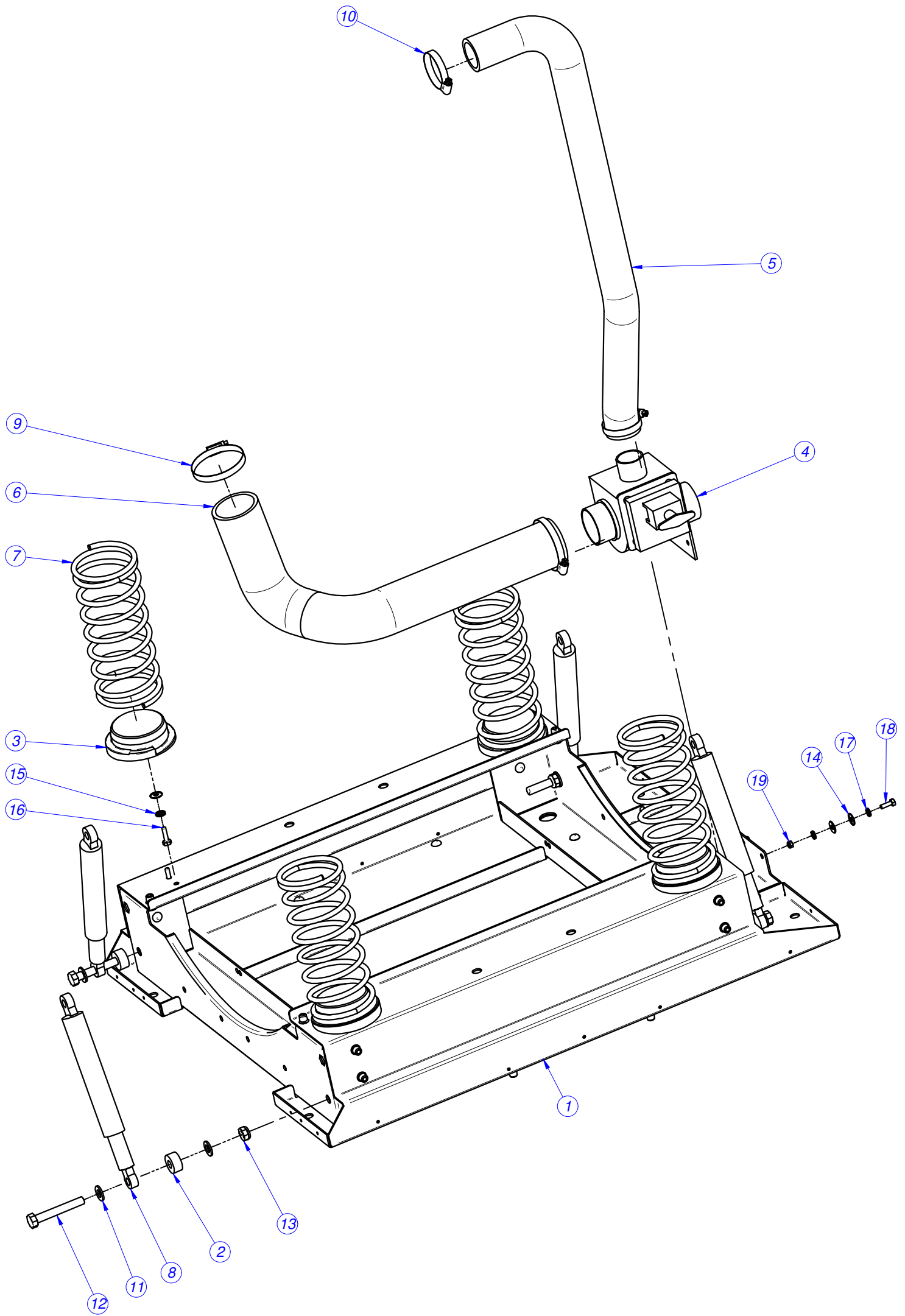

MOD.	LAVADORA LA-10 M		ZONA	ARMAZON	
Nº	CODIGO	DENOMINACION	Cant.		
1	P610114000	ARMAZON COMPLETO 10	1		
2	P620107000	CASQUILLO AMORTIGUADORES	4		
3	P620106000	BASE MUELLE	4		
4	P302120000	VALVULA	1		
5	P610702000	CONDUCTO REBOSADERO 8	1		
6	P610703000	CONDUCTO DESAGUE 8	1		
7	P610105000	MUELLE 8	4		
8	P620115000	AMORTIGUADOR 120N SUSPA	4		
9	Q881324000	ABRAZADERA 50-70L	2		
10	Q881306000	ABRAZADERA 32-50L	2		
11	Q232060000	ARANDELA A10	8		
12	Q011369000	TORN.EX.M10X70 H.ZINCADO	4		
13	Q221306000	TUE.EX.AUT.M10 8.8 ZIN	4		
14	Q302022000	ARANDELA 16X6X1.2 A.304	12		
15	Q242040000	ARAND.ABAN. A6 A.304	8		
16	Q012043000	TORN.EXA. M6X20 A.304	8		
17	Q242030000	ARAND.ABAN. A5 A.304	4		
18	Q012032000	TORN.EXA. M5X15 A.304	2		
19	Q221308000	TUE.EX.AUT.M5 H.ZINCADA	2		

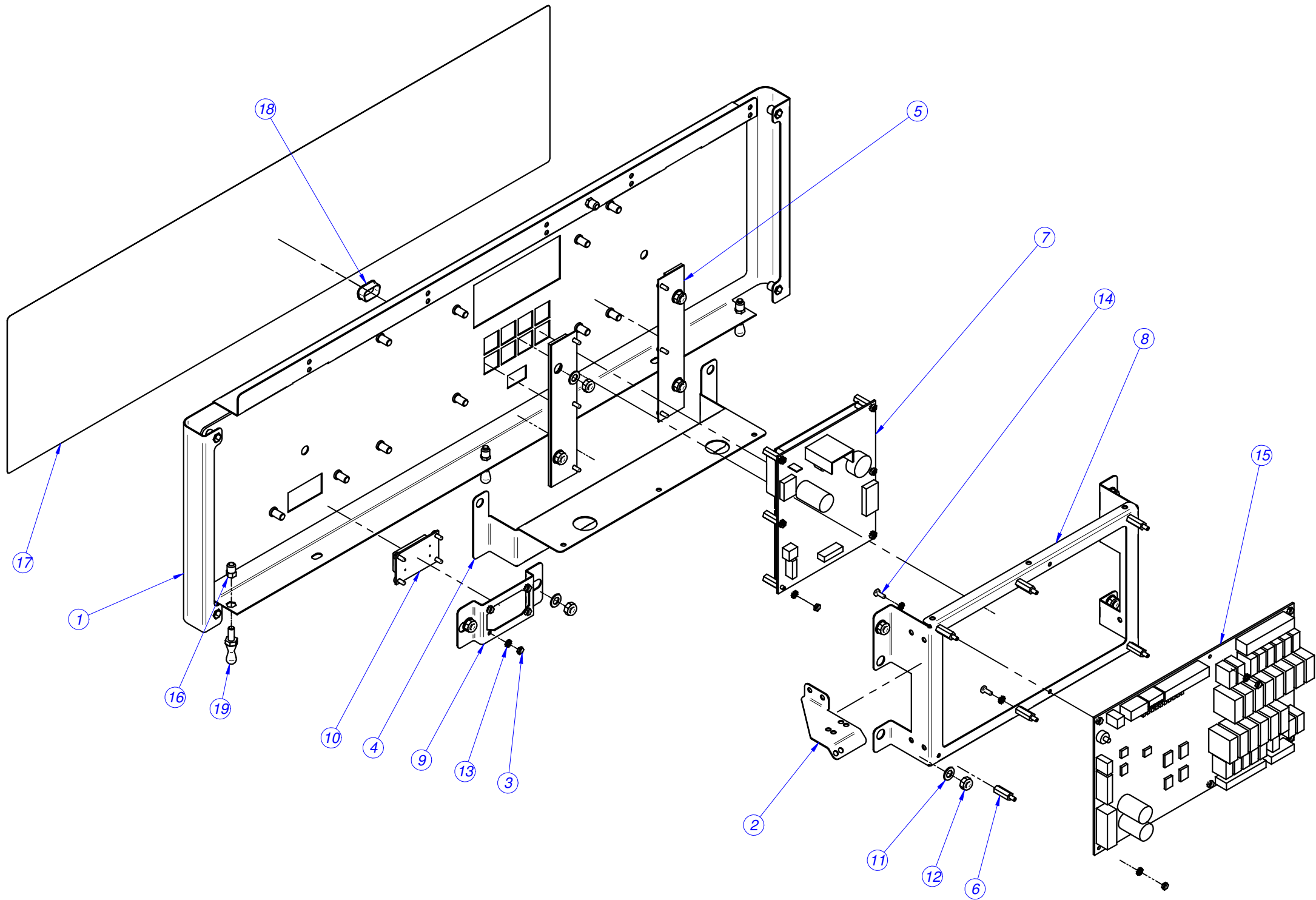

<b>MOD.</b>	<b>LAVADORA LA-10 MPP</b>		<b>ZONA</b>	<b>PORTAMANDOS</b>	
<b>Nº</b>	<b>CODIGO</b>	<b>DENOMINACION</b>	<b>Cant.</b>		
1	P610318000	PORTA MANDOS COMP. 8 MPP	1		
2	P620359000	SUJECION MANGUERA PRESOSTATO	1		
3	Q162010000	TUER.EXA.M3	16		
4	P530404000	CUBIERTA PROGRAMADOR 25	1		
5	P620344000	SOPORTE PROGRAMADOR COMPL.	2		
6	T133007000	DISTANCIADOR M3	12		
7	P613006000	CIRCUITO VISUALIZACION	1		
8	P620328000	SOPORTE PLACA	1		
9	P620338000	PORTA INTERRUPTOR C.I.	1		
10	P623017000	INTERRUPTOR GENERAL C.I.	1		
11	Q232040000	ARANDELA A6	10		
12	Q222012000	TUER.AUTOB.M6	10		
13	Q242010000	ARAND.ABAN. A.3 A304	22		
14	T133008000	TORNILLO AMARRE M3	16		
15	P613005000	PLACA ENTRADAS-SALIDAS	1		
16	Q221342000	REMACHE EXAGONAL M5	8		
17	P610310000	ADHESIVO PORTAMANDOS MPP	1		
18	P613014000	TAPON PUERTO SERIE PROG.	1		
19	P450303000	PITON DE CIERRE	3		

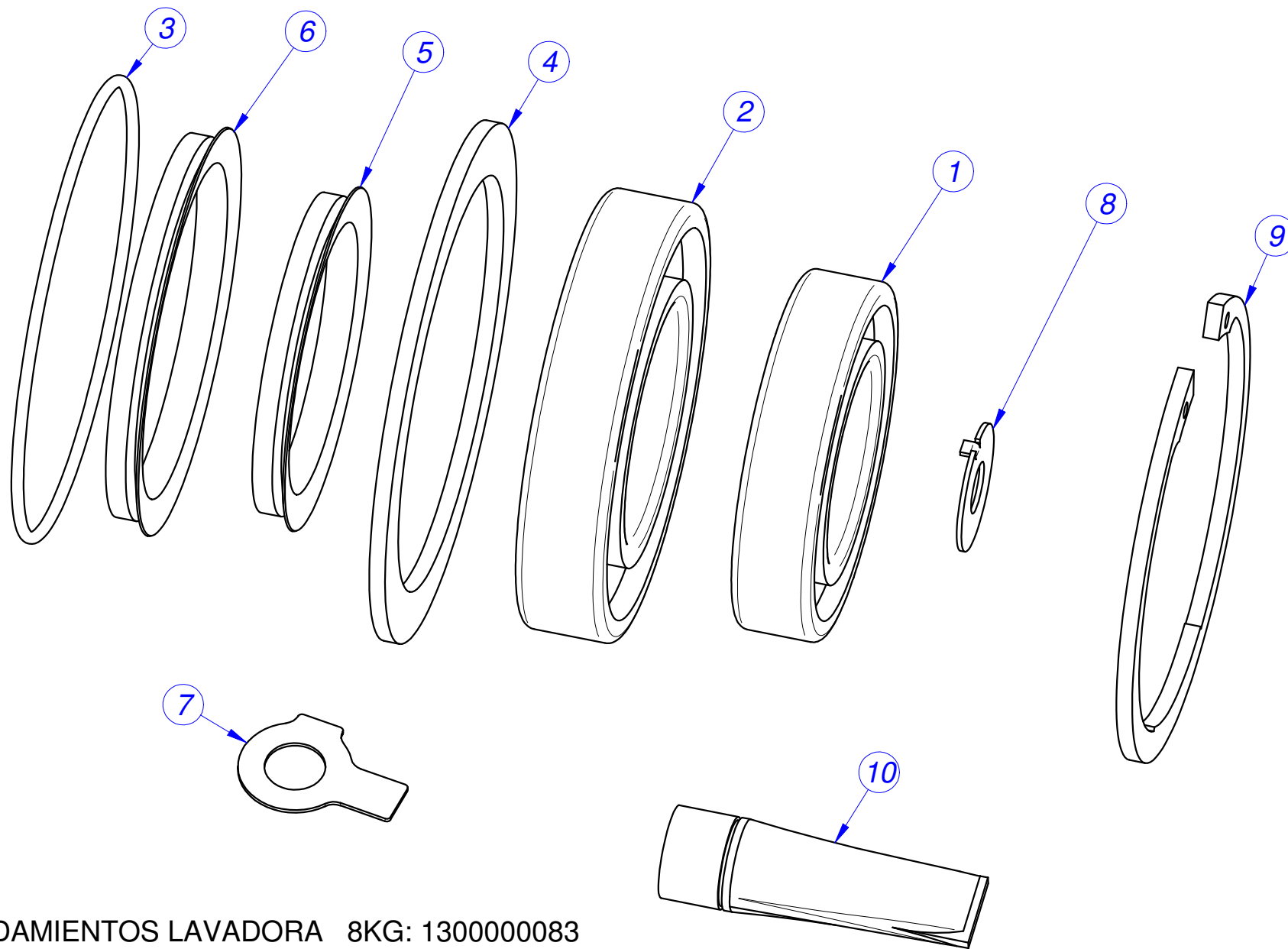

KIT RODAMIENTOS LAVADORA 8KG: 1300000083

KIT RODAMIENTOS LAVADORA 13KG: 1300000084

KIT RODAMIENTOS LAVADORA 18KG: 1300000085

**KIT RODAMIENTOS 8 KG**  
**REF: 130000083**

<i>Nº COMPONENTES QUE INCLUYE EL KIT 130000083</i>	<i>DENOMINACIÓN DE COMPONENTES QUE INCLUYE EL KIT 130000083</i>	<i>CODIGO</i>	<i>CANTIDAD</i>
<i>Componente nº1</i>	<i>Rodamiento 55/100/21</i>	<i>P616009</i>	<i>1</i>
<i>Componente nº2</i>	<i>Rodamiento 45/85/19</i>	<i>P616008</i>	<i>1</i>
<i>Componente nº3</i>	<i>Junta tórica 102x3</i>	<i>Q307073</i>	<i>1</i>
<i>Componente nº4</i>	<i>Junta casquillo retenes 8</i>	<i>P616007</i>	<i>1</i>
<i>Componente nº5</i>	<i>Retén V-RING 63</i>	<i>P614911</i>	<i>1</i>
<i>Componente nº6</i>	<i>Retén V-RING 78</i>	<i>P634911</i>	<i>1</i>
<i>Componente nº7</i>	<i>Arandela de seguridad 13</i>	<i>Q271302</i>	<i>8</i>
<i>Componente nº8</i>	<i>Arandela de seguridad 13</i>	<i>Q301329</i>	<i>1</i>
<i>Componente nº9</i>	<i>Anillo seguridad int. 85</i>	<i>Q301044</i>	<i>1</i>
<i>Componente nº10</i>	<i>Grasa amblygon TA 15/2</i>	<i>P536544</i>	<i>1</i>

**KIT RODAMIENTOS 13 KG**  
**REF: 130000084**

<i>Nº COMPONENTES QUE INCLUYE EL KIT 130000084</i>	<i>DENOMINACIÓN DE COMPONENTES QUE INCLUYE EL KIT 130000084</i>	<i>CODIGO</i>	<i>CANTIDAD</i>
<i>Componente nº1</i>	<i>Rodamiento 50/90/20</i>	<i>P626008</i>	<i>1</i>
<i>Componente nº2</i>	<i>Rodamiento 60/110/22</i>	<i>P626009</i>	<i>1</i>
<i>Componente nº3</i>	<i>Junta tórica 114x3</i>	<i>Q307075</i>	<i>1</i>
<i>Componente nº4</i>	<i>Junta casquillo retenes 13</i>	<i>P626007</i>	<i>1</i>
<i>Componente nº5</i>	<i>Retén V-RING 70</i>	<i>P624913</i>	<i>1</i>
<i>Componente nº6</i>	<i>Retén V-RING 85</i>	<i>P624914</i>	<i>1</i>
<i>Componente nº7</i>	<i>Arandela de seguridad 13</i>	<i>Q271302</i>	<i>8</i>
<i>Componente nº7</i>	<i>Arandela de seguridad 15</i>	<i>Q271303</i>	<i>8</i>
<i>Componente nº8</i>	<i>Arandela de seguridad 13</i>	<i>Q301329</i>	<i>1</i>
<i>Componente nº9</i>	<i>Anillo seguridad int. 90</i>	<i>Q301030</i>	<i>1</i>
<i>Componente nº10</i>	<i>Grasa amblygon TA 15/2</i>	<i>P536544</i>	<i>1</i>

**KIT RODAMIENTOS 18 KG**  
**REF: 130000085**

<i>Nº COMPONENTES QUE INCLUYE EL KIT 130000085</i>	<i>DENOMINACIÓN DE COMPONENTES QUE INCLUYE EL KIT 130000085</i>	<i>CODIGO</i>	<i>CANTIDAD</i>
<i>Componente nº1</i>	<i>Rodamiento 60/110/22</i>	<i>P626009</i>	<i>1</i>
<i>Componente nº2</i>	<i>Rodamiento 70/125/24</i>	<i>P626008</i>	<i>1</i>
<i>Componente nº3</i>	<i>Junta tórica 128x3</i>	<i>Q307077</i>	<i>1</i>
<i>Componente nº4</i>	<i>Junta casquillo retenes 18</i>	<i>P636005</i>	<i>1</i>
<i>Componente nº5</i>	<i>Retén V-RING 78</i>	<i>P634911</i>	<i>1</i>
<i>Componente nº6</i>	<i>Retén V-RING 92</i>	<i>P634912</i>	<i>1</i>
<i>Componente nº7</i>	<i>Arandela de seguridad 15</i>	<i>Q271303</i>	<i>8</i>
<i>Componente nº8</i>	<i>Arandela de seguridad 13</i>	<i>Q301329</i>	<i>1</i>
<i>Componente nº9</i>	<i>Anillo seguridad J110x4</i>	<i>Q301036</i>	<i>1</i>
<i>Componente nº10</i>	<i>Grasa amblygon TA 15/2</i>	<i>P536544</i>	<i>1</i>

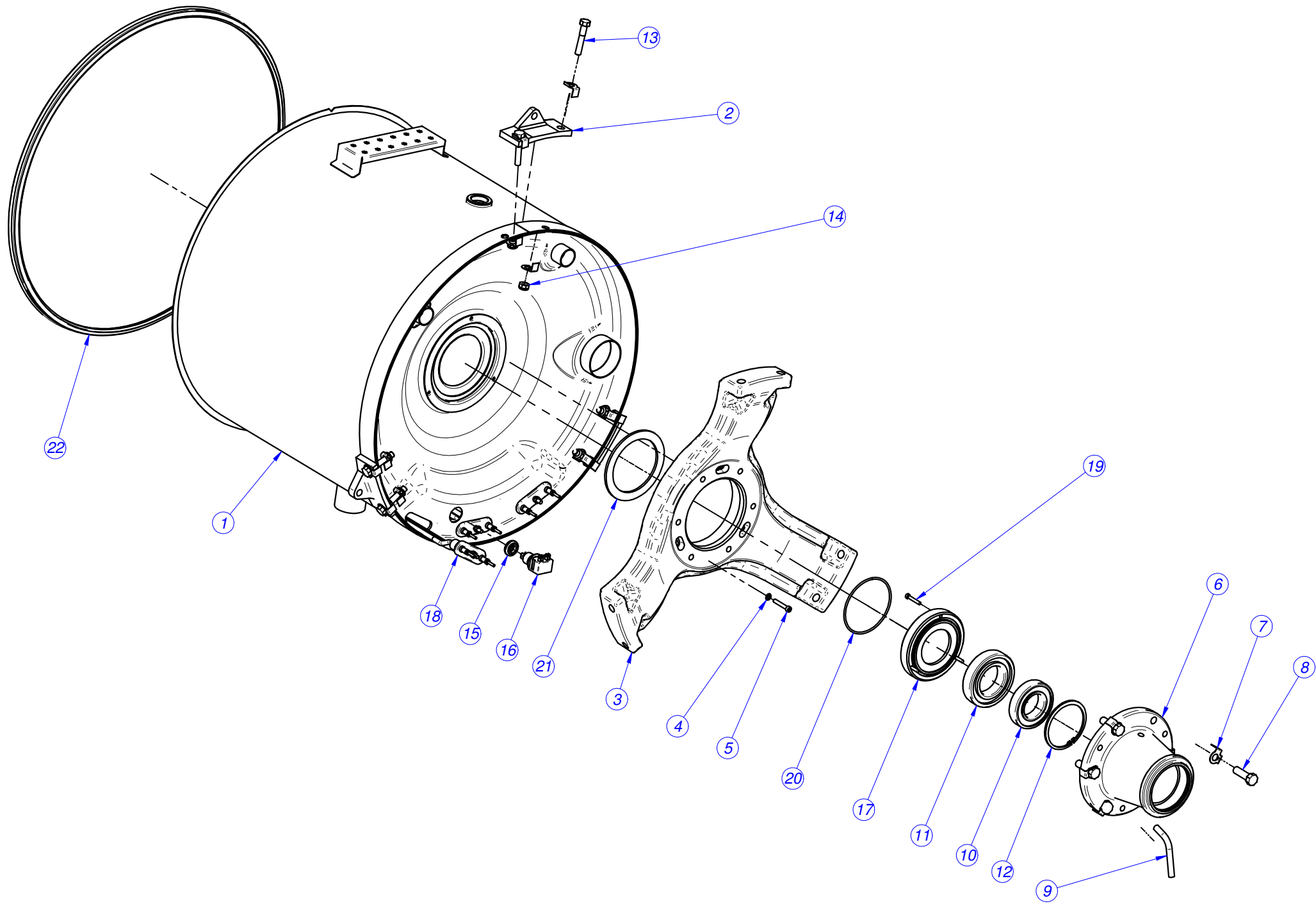

<b>MOD.</b>	<b>LAVADORA LA-10 M</b>		<b>ZONA</b>	<b>CUBA</b>	
<b>Nº</b>	<b>CODIGO</b>	<b>DENOMINACION</b>	<b>Cant.</b>		
1	P616117000	CUBA COMPLETA 10	1		
2	P616011000	APOYO TORNILLOS 8	3		
3	P616003000	REFUERZO FONDO CUBA 8	1		
4	Q232040000	ARANDELA A6	3		
5	Q122045000	TORN. ALLEN M6x35 INOX	3		
6	P616004000	SOPORTE RODAMIENTOS 8	1		
7	Q271301000	ARAND. SEG. 10.5 DIN 463	18		
8	Q012076000	TORN. EXAG. M12x40 INOX	6		
9	P626015000	TUBO EVACUACION 8,13,18	1		
10	P616008000	RODAMIENTO 6209-2Z	1		
11	P616009000	RODAMIENTO 6211-2RS1	1		
12	Q301044000	ANILLO SEG. INT. 85	1		
13	Q012068000	TORN. EXAG. M10x55 DIN 931	6		
14	Q221306000	TUE.EXAUT.M10 8.8 ZIN	6		
15	Z953003000	PASAMUROS BULBO	1		
16	P503025000	SONDA	1		
17	P616005000	CASQUILLO CONTRA RETEN 8	1		
18	P613008000	RESISTENCIA LF-8	3		
19	Q122034000	TORN. ALLEN M5x30 INOX	3		
20	Q307073000	JUNTA TOR. 102x3	1		
21	P616007000	JUNTA CASQUILLO RETENES 8	1		
22	P616104000	JUNTA CUBA 8	1		



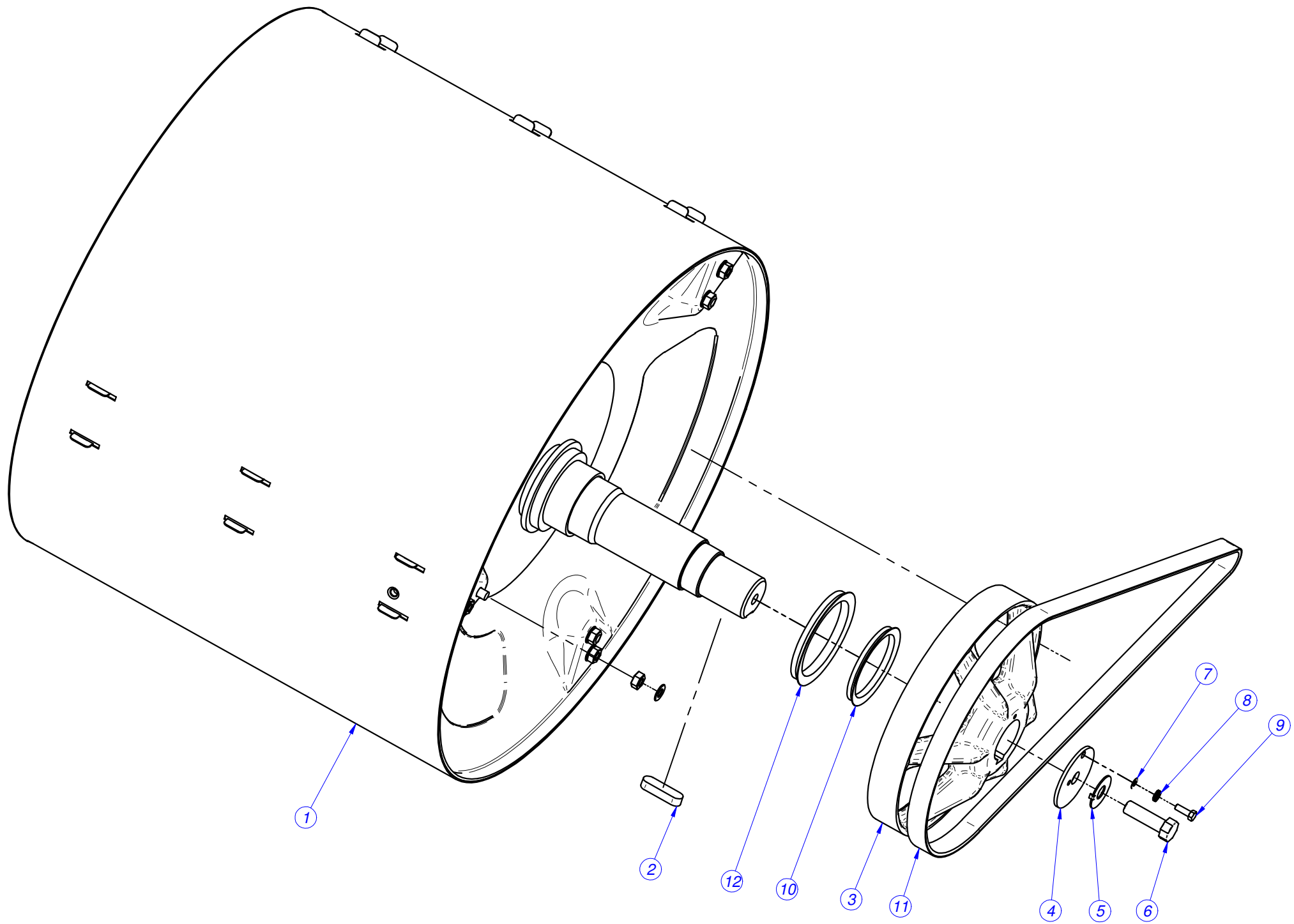

<b>MOD.</b>	<b>LAVADORA LA-10 M</b>		<b>ZONA</b>	<b>TAMBOR</b>	
<b>Nº</b>	<b>CODIGO</b>	<b>DENOMINACION</b>	<b>Cant.</b>		
1	P614916000	TAMBOR COMPLETO 10	1		
2	P614914000	CHAVETA 12x8x40	1		
3	P616006000	POLEA TAMBOR 8	1		
4	P616010000	ARANDELA POLEA 8	1		
5	Q301329000	ARANDELA SEGURIDAD 13	1		
6	Q011376000	TOR.EX.M12X40 H.ZINCADO	1		
7	Q232030000	ARANDELA A5	1		
8	Q242030000	ARAND.ABAN. A5 A.304	1		
9	Q012032000	TORN.EXA. M5X15 A.304	1		
10	P614911000	RETEN V-RING 65	1		
11	P615902000	CORREA LF-8	1		
12	P614912000	RETEN V-RING 75	1		

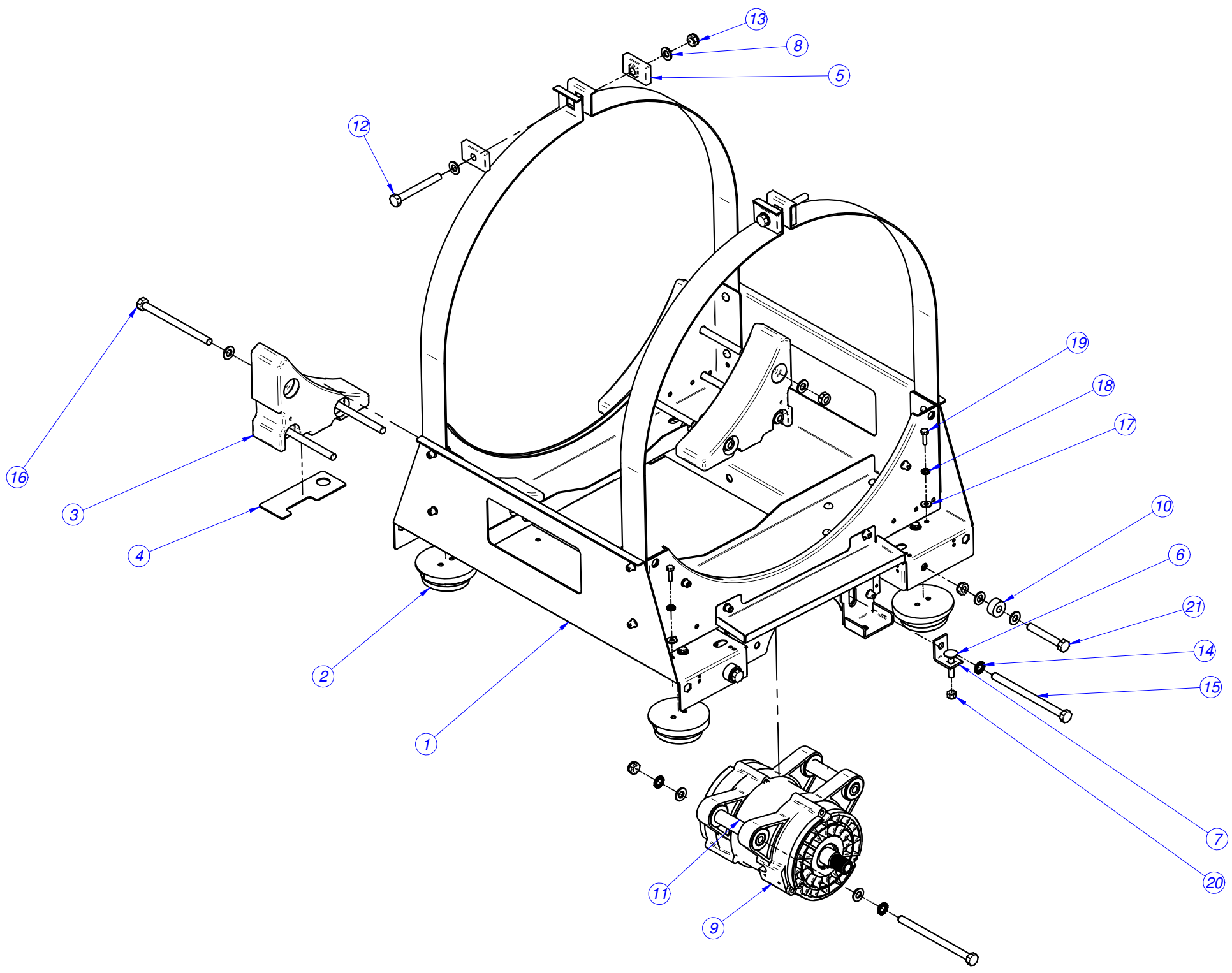

<b>MOD.</b>	<b>LAVADORA LA-10 M</b>		<b>ZONA</b>	<b>CUNA</b>	
<b>Nº</b>	<b>CODIGO</b>	<b>DENOMINACION</b>	<b>Cant.</b>		
	codigo	titulo			
1	P610216000	CUNA COMPLETA 10	1		
2	P620106000	BASE MUELLE	4		
3	P610207000	CONTRAPESO 8	4		
4	P610212000	APOYO CONTRAPESO 8, 13	2		
5	P620208000	AMARRE CUBA	4		
6	Q151393000	TORN DIN 603 M8x35	1		
7	P620214000	TENSOR MOTOR	1		
8	Q232060000	ARANDELA A10	27		
9	P615906000	MOTOR 8	1		
10	P620107000	CASQUILLO AMORTIGUADORES	4		
11	P615908000	TUBO SOPORTE MOTOR 8	2		
12	Q011360000	TORNILLO EXAGONAL M10X80	2		
13	Q221306000	TUE.EX.AUT.M10 8.8 ZIN	14		
14	Q241560000	ARAND. ABAN. A10 DIN6798	4		
15	Q151525000	EXAG. M10X150(8.8) DIN931	2		
16	Q151394000	TORN. EXAG. M10x140	6		
17	Q302022000	ARANDELA 16X6X1.2 A.304	8		
18	Q242040000	ARAND.ABAN. A6 A.304	8		
19	Q012043000	TORN.EXA. M6X20 A.304	8		
20	Q221309000	TUE.EX.AUT.M8 8.8 ZINCADA	1		
21	Q011369000	TORN.EX.M10X70 H.ZINCADO	4		

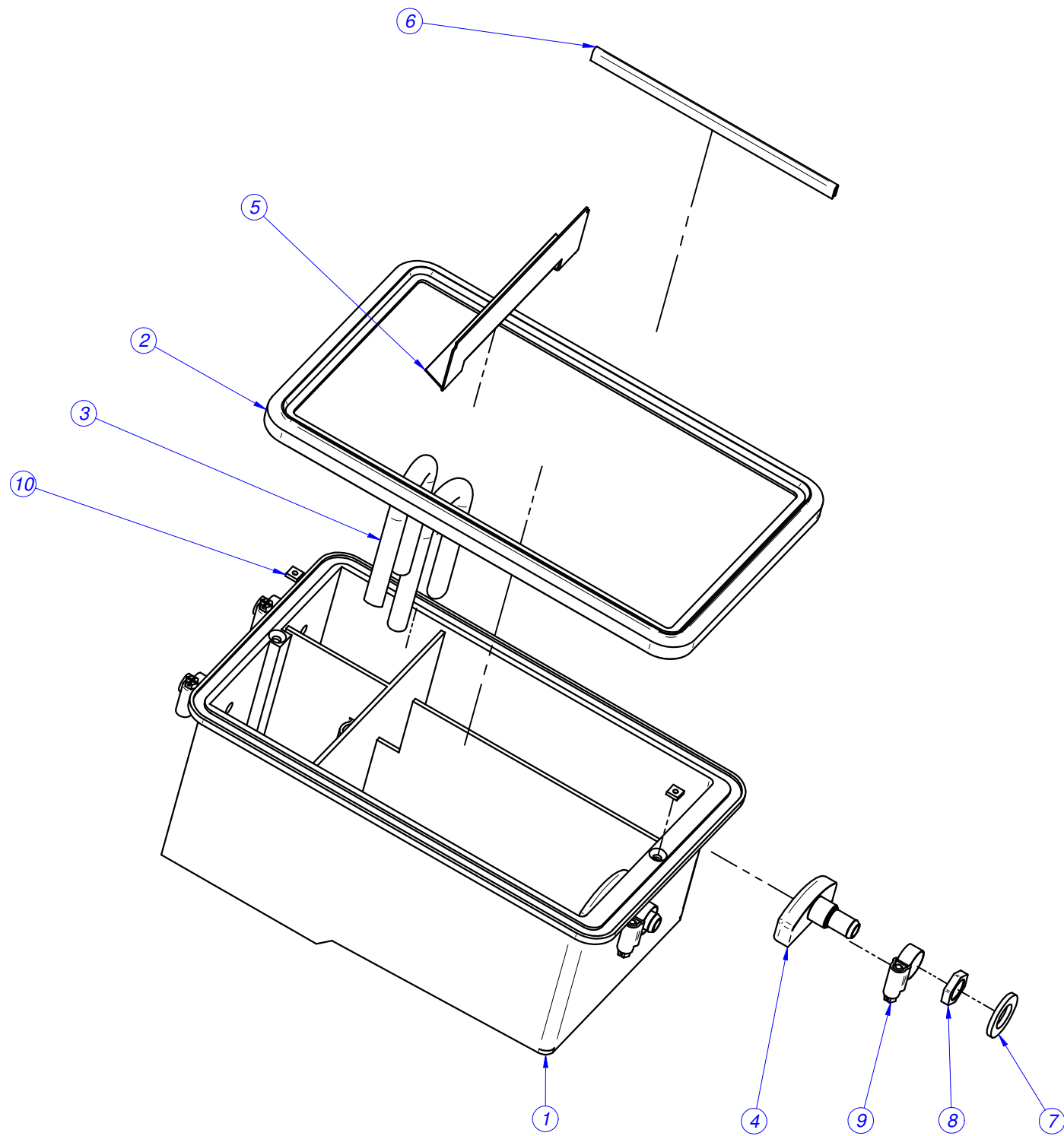

<b>MOD.</b>	<b>LAVADORA LA-10 M</b>		<b>ZONA</b>	<b>CUBETERA</b>	
<b>Nº</b>	<b>CODIGO</b>	<b>DENOMINACION</b>	<b>Cant.</b>		
1	P440700000	CUBETA DE DETERGENTES	1		
2	P500702000	JUNTA CUBETA 1003431	1		
3	P440702000	TUBO SIFON	2		
4	P440701000	DIFUSOR DE DETERGENTES	2		
5	P440715000	ESCUADRA PROTECCION	1		
6	P440721000	PERFIL REFUERZO	1		
7	Q301302000	ARANDELA PLANA A17	2		
8	Q223018000	TUERCA 16X1,5	2		
9	Q881305000	ABRAZADERA 25-40	4		
10	Q222004000	TUERCA CUADRADA M.4	2		

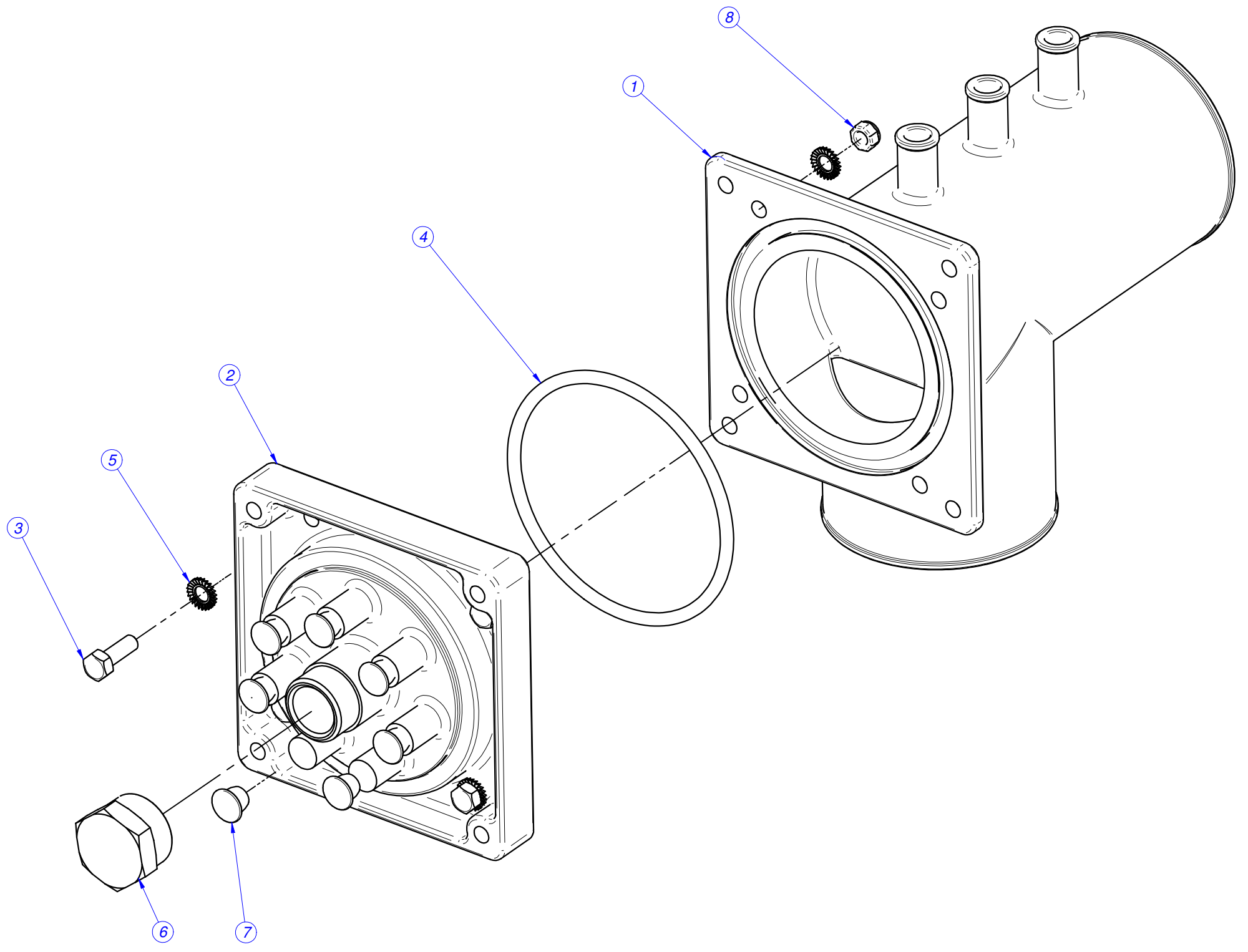

<b>MOD.</b>	<b>LAVADORA LA-10 M</b>		<b>ZONA</b>	<b>TOMA DOSIFICACION</b>	
<b>Nº</b>	<b>CODIGO</b>	<b>DENOMINACION</b>	<b>Cant.</b>		
	P620707000	TOMA DOSIFICACION COMPLETA	1		
1	P620701000	TOMA DOSIFICACION INT. P	1		
2	P620706000	TOMA DOSIFICACION EXTERIOR	1		
3	Q012032000	TORN.EXA. M5X15 A.304	4		
4	Q307081000	JUNTA TORICA 75x4	1		
5	Q242030000	ARAND.ABAN. A5 A.304	8		
6	P620710000	TAPA 1/2"	1		
7	P620709000	TAPON DOSIFICADORES	7		
8	Q222030000	TUER.AUTOB.M5	4		



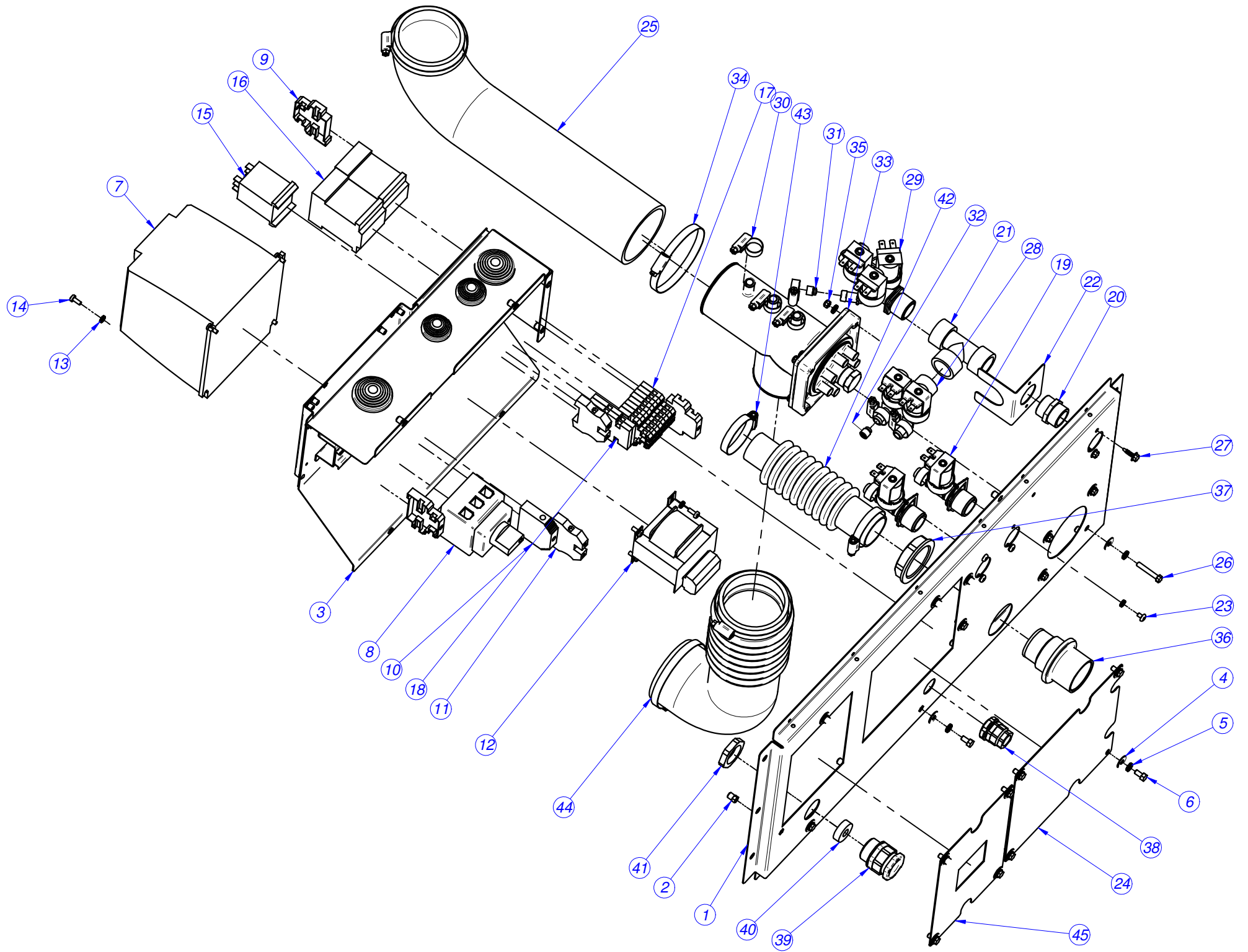

MOD.	LAVADORA LA-10 MPP		ZONA	SOPORTE ELECTROV.	
Nº	CODIGO	DENOMINACION	Cant.		
1	P610325000	PANEL POSTERIOR TOMAS 8 V2	1		
2	Q221342000	REMACHE EXAGONAL M5	14		
3	P620347000	PORTA CUADRO ALIMEN. COMP.V2	1		
4	Q302022000	ARANDELA 16X6X1.2 A.304	18		
5	Q242030000	ARAND.ABAN. A5 A.304	22		
6	Q012031000	TORN.EXA. M5X10 A.304	14		
7	P613007000	VARIADOR 1.1 Kw	1		
8	P623003000	SECCIONADOR 32A	1		
9	Z263303000	TOPE FINAL	3		
10	Z263302000	BORNA DE PASO AZUL	1		
11	P453026000	BORNE TIER 10 WPE-10103.O	2		
12	P623004000	TRANSFORMADOR 20020-024	1		
13	Q242020000	ARAND.ABAN. A.4 A304	12		
14	Q032021000	TORN.ALOM.M4X10	8		
15	Z203062000	RELE 230V. 16A 50-60 HZ	1		
16	Z203050000	CONTAC. SIRIUS 3R 230V.50-60	2		
17	P623006000	REGLETA BORNAJE 2 PISOS	8		
18	R073005000	BORNAS PORTA FUSIBLES	2		
19	Z701135000	E.V.SIMP.220V COD.255.208	2		
20	Z102301000	MANGUITO 3/4"	1		
21	P535020000	Te a 90º-3/4"	1		
22	P535003000	TOPE ELECTROVALVULA	1		
23	Q151320000	TOR.ALO.M4X6 H.ZINCADO	4		
24	P620342000	TAPA POSTERIOR V2	1		
25	P620705000	CONDUCTO CUBETA-DOSIF. 13	1		
26	Q011353000	TORNILLO EXAGONAL M5X30	4		
27	Q151323000	TORN.BROCA 4,8X16	2		
28	P255001000	ELECTROVALVULA DOBLE	1		
29	Z611123000	E.V. TRIPLE COD.255.641	1		
30	Q881302000	ABRAZADERA 12-20	10		
31	P443042000	REGULADOR 3L NE.254.023	1		
32	Z601156000	REGULADOR 8L RO. 254.034	1		
33	P620707000	TOMA DOSIFICACIÓN COMPLETA	1		
34	Q881326000	ABRAZADERA 70-90	4		
35	Q222030000	TUER.AUTOB.M5	4		
36	Z740701000	PASAMUROS ARBOL LAVADO	1		
37	Z710708000	TUERCA PASAMUROS	1		
38	R073004000	PRENSA ESTOPAS	1		
39	R023013000	PRENSA ESTOPAS PG-21	1		
40	R023026000	JUNTA GOMA (GAES)	1		
41	Q223016000	TUERCA ROSCA Pg 21	1		
42	P620708000	CONDUCTO SALIDA VAPOR	1		
43	Q881306000	ABRAZADERA 32-50L	2		
44	P610704000	CONDUCTO DOSIFICADOR CUBA 8	1		
45	P620341000	TAPA SECCIONADOR V2	1		

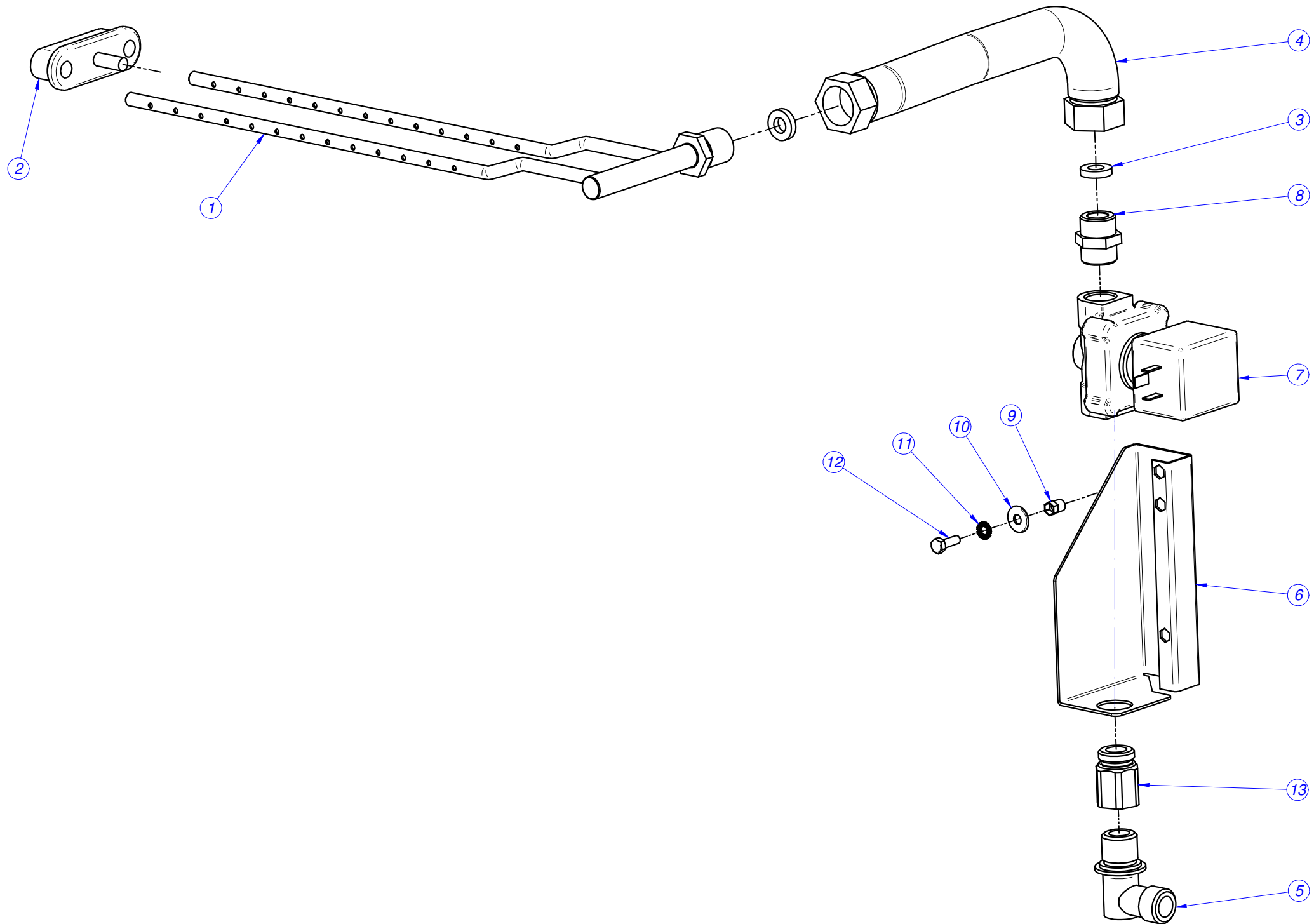

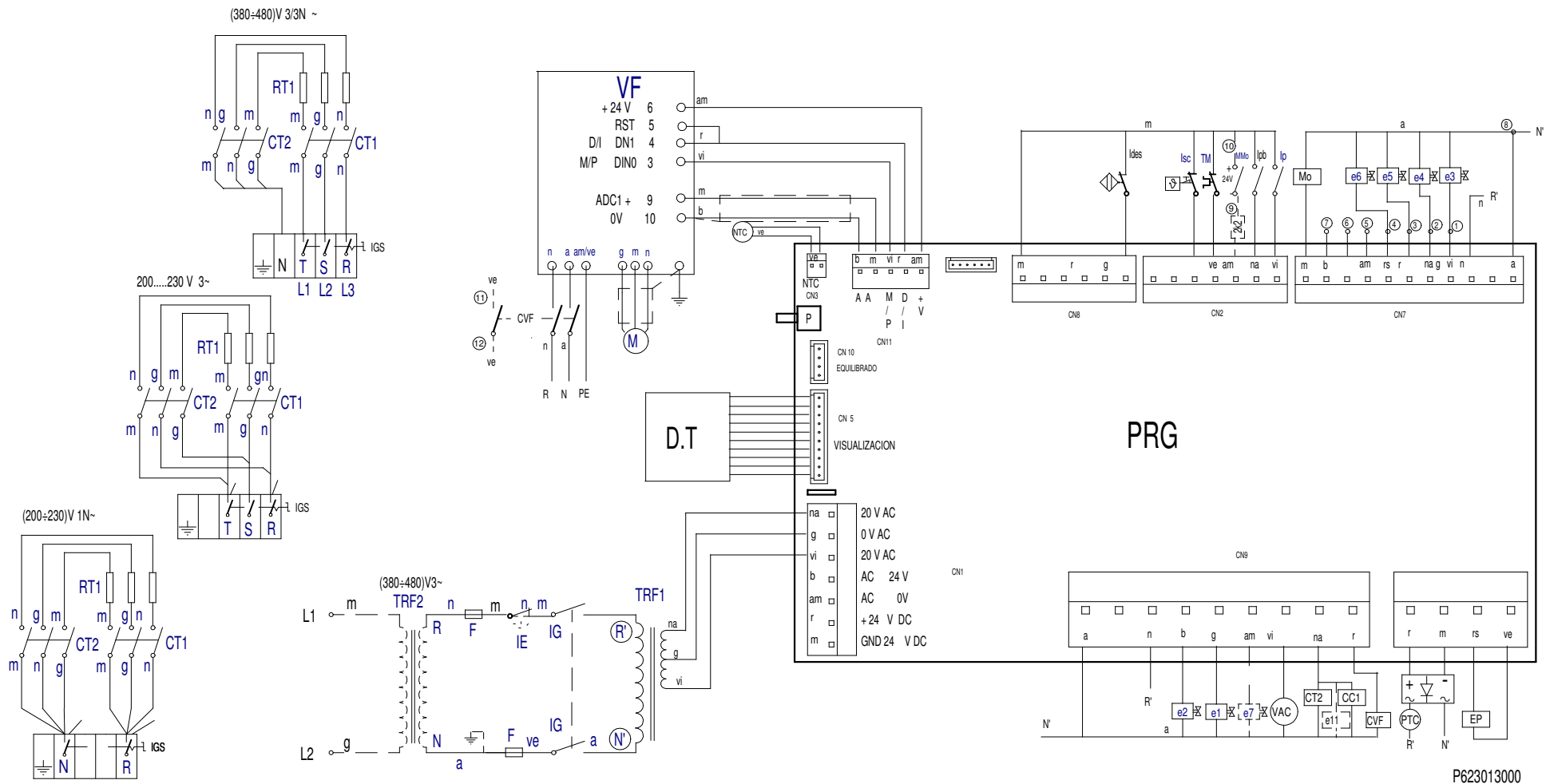

<b>MOD.</b>	<b>LAVADORA LA-10 M</b>		<b>ZONA</b>	<b>CONJUNTO VAPOR</b>	
<b>Nº</b>	<b>CODIGO</b>	<b>DENOMINACION</b>	<b>Cant.</b>		
1	P615001000	INYECTOR VAPOR 8,13,18	1		
2	P445011000	CIERRE COMPLETO	1		
3	P615002000	ARANDELA VAPOR 8/13/18	2		
4	P525005000	LATIGUILLO VAP.LF-14	1		
5	S115013000	CODO LATON	1		
6	P620327000	SOPORTE VALVULA DE VAPOR	1		
7	P505012000	VALVULA VAPOR 1/2" 50HZ	1		
8	S205023000	MANGUITO DOBLE 1/2	1		
9	Q221342000	REMACHE EXAGONAL M5	1		
10	Q302022000	ARANDELA 16X6X1.2 A.304	1		
11	Q242030000	ARAND.ABAN. A5 A.304	1		
12	Q012032000	TORN.EXA. M5X15 A.304	1		
13	X162101000	RACOR 1-2	1		

Instalaciones	Referencia	LAV 10	LAV 13	LAV 18
Cableado Programador - Teclado lav 10, 13, 18 Kg *	P-623009	X	X	X
Cableado Resistencias 10, 13, 18 Kg *	P-623008	X	X	X
Cableado Puerta *	P-623010	X	X	X
Circuito Programador Lavd	P-613005	X	X	X
Circuito Vis-Tecl Lavd	P-613006	X	X	X
Indicador de componentes Lav	P-623011	X	X	X
Interruptor general C.I. *	P-623017	X	X	X
Leyenda Lav	P-623014	X	X	X
Componentes	Referencia	LAV 8	LAV 13	LAV 18
Borne doble piso 2,5mm Weidmuller DK 4/35 5276.6	P-623006	7	7	7
Borne Azul 10mm	Z-263302	1	1	1
Borne Azul 35mm **	R-673010			
Borne Portafusible	R-073005	2	2	2
Borne tierra 10mm	P-453026	2	2	2
Borne tierra 35mm **	Z-103035			
Condensador antiparasitario 0,1 uF *	Z-233012	7	7	7
Contactador 20A NA	Z-203050	2	2	2
Contactador 35 A	P-433030			
Contactador 60 A	X-183011			
Electrovalvula simple	Z-701135	2	2	2
Electrovalvula doble	P-255001	X	X	X
Electrovalvula Triple	Z-611123	X	X	X
Electrovalvula simple 120 L/h Z-102305	Z-102323			
Electroiman	P-613002	X	X	X
Fusible 4A Modificar *	P-184011	2	2	2
Interruptor magnetico desequilibrio NO *	Z-100522	X	X	X
Monedero	P-613004	X	X	X
Motor 10	P-615904	X		
Motor 13	P-625905		X	
Motor 18	P-635906			X
PG-21 Prensaestopas	R-023013	X	X	X
PG21 Tuerca	Q-223016	X	X	X
PG21 Junta de goma				
PG36 Junta de goma				
PG36 Prensaestopas	R-143010			
PG36 Tuerca				
Regleta 2,5 mm <sup>2</sup> TEKOX1106PL *	R-693010	2/12	2/12	2/12
Regleta 6 mm <sup>2</sup> 1/12 *	Z-713035			
Regleta 16 mm <sup>2</sup> 1/6 Elettro Gibi *	Z-743006			
Rele 16 A 2NA 230V 50/60Hz Faston FINDER	Z-203062	X	X	X
Resistencia 2KW	P-613008	3		
Resistencia 3KW	P-623005		3	
Resistencia 4KW	P-633002			3
Resistencia 6KW	P-533001			
Señalización R,S,T,N,PE	Z-683068	X	X	X
Seccionador 32A 11,5kw Siemens 3LD22 30-OTK13	P-623003	X	X	X
Seccionador 63 A 22 kw Siemens 3LD25 30-OTK13	P-537038		240 V 1N	240 V 1N
Seccionador 125 A 45 Kw Siemens 3LD28 30-OTK13	P-543039			
Sonda NTC + Limitador	P-503025	X	X	X
Terminal mini Mate-n-lok Hembra 170362-1	P-623016			
Tope final 10mm	Z-263303	X	X	X
Tapa Cubierta conector Sub-D	P-613014	X	X	X
Transformador 230/20-0-20 24-0	P-623004	X	X	X
Variador 10Kg	P-613007	X		
Variador 13Kg	P-623002		X	
Variador 18Kg	P-633003			X
Valvula de vaciado 10, 13, 18 Kg	P-302120	X	X	X



P623013000

L/

-	Esquema teorico lavadoras 8,13,18	-	-	P623013000	-	
Zk./Nº	Pieza	Cant.	Materiala/Material	Klas. zk/Nº Clas.	Gainazal akabera/Tratamiento	
Zk./Nº	Aldaketa/Modificaciones		Nork proposatua/Propuesta de	Data/Fecha	Perdoi orokorrak Tolerancias generales	
2	Introducir puente en VF entre 4 y 5		M.Mailla	21-03-2005		
3	Cambiar conexión CVC		M.Mailla	10-05-2005	$< 5 \pm 0.2$   $50 \div 100 \pm 0.8$	
4	Eliminar nombres		C.Tytgat	18-01-2006	$5 \div 25 \pm 0.4$   $> 100 \pm 1$	
5			M.Mailla	18-03-2006	$25 \div 50 \pm 0.6$   $\alpha \pm 1$	
6	Introducir PTC para cierre puerta		M.Mailla	18-04-2007		
	Sinadura/Firma	Data/Fecha	<b>FAGOR</b>  Fagor Industrial,Koop.Elk, Mugatua		Gainazal perdoia Mecanizado superficial	
	Marraztua/Dibujado	M. Mailla 14-07-2004				
	Proiektatua/Proyectado	M.Mailla 14-07-2004				
	Egiaztatua/Comprobado	 21-07-2004				
	Eskala/Escala				Plano Zk./Plano Nº -6	
					- Zk. ord. du	
					- Zk.gaitik ord.	

Simb / LENG	ESPAÑOL	FRANÇAIS	ENGLISH	DEUTSCH	ITALIANO
CT =	Contacto Calentamiento	Contacteur Chauffe	Heating Contactor	Heizschütz	Contatore Riscaldamento
DP =	Detector posición.	Détecteur position	Position detector	Stellung Taster	Rilevatore posizione
DS1	Dosificador Neutralizante.	Doseur Neutralisant	Neutralizer feeder	Dosiervorrichtung Neutralpulmittel	Dosatore Neutralizzante
DS2	Dosificador jabon liquido.	Doseur lessive liquide	Liquid soap feeder	Dosiervorrichtung Flüssigseife	Dosatore sapone liquido
DS3	Dosificador aditivos.	Doseur additifs	Additive feeder	Dosiervorrichtung Zusatzmittel	Dosatore additivi
D.T.	Display/Teclado	Ecran/Clavier	Display/Keyboard	Display/Tastatur	Display/Tastiera
e1 =	Electro válvula agua Fria.	Électrovanne eau Froide	Cold water electrically operated valve	Elektroventil Kaltwasser	Elettrovalvola acqua Fredda
e2 =	Electro válvula agua Caliente	Électrovanne eau Chaude	Hot water electrically operated valve	Elektroventil Warmwasser	Elettrovalvola acqua Calda
e3 =	Electro válvula Prelavado.	Électrovanne Prélavage	Pre-wash electrically operated valve	Elektroventil Vorwaschen	Elettrovalvola Prelavaggio
e4 =	Electro válvula Lavado.	Électrovanne Lavage	Wash electrically operated valve	Elektroventil Hauptwaschgang	Elettrovalvola Lavaggio
e5 =	Electro válvula Lejia.	Électrovanne Eau de Javel	Bleach electrically operated valve.	Elektroventil Bleiche	Elettrovalvola Candeggina
e6 =	Electro válvula Suavizante.	Électrovanne Assouplissant	Fabric softener electrically operated valve	Elektroventil Weichspüler	Elettrovalvola Ammorbidente
e7 =	Electro válvula agua Descalcificada	Électrovanne eau Adoucie	Delimed water electrically operated valve	Elektroventil entkalktes Wasser	Elettrovalvola acqua Decalcificata
e8 ,9,10 =	Electro válvula Equilibrado	Électrovanne Équilibrage	Balancer electrically operated valve	Elektroventil Gleichgewicht	Elettrovalvola Bilanciamento
e11 =	Electro válvula Vapor.	Électrovanne Vapeur	Steam electrically operated valve	Elektroventil Dampf	Equilibrado Vapore
EP =	Electroímán de Puerta.	Électro-aimant de Porte	Door electric magnet	Elektromagnet Gerätetür	Elettromagnete Porta
FI =	Filtro de Interferencias.	Filtre Anti-parasites	Interference filter	Störungsfilter	Filtro Interferenze
F =	Fusible.	Fusible	Fuse	Sicherung	Fusibile
G1,G2 =	Galga Sensor.	Jauge Capteur	Sensing gage	Meßsensor	Calibro Sensore
IE =	Pulsador Parada de emergencia.	Bouton-poussoir Arrêt d'urgence	Emergency stop push button	Not-Aus-Taster	Pulsante Arresto di emergenza
IG =	Interruptor general.	Interrupteur général	General switch	Hauptschalter	Interruttore generale
IGS =	Interruptor General de seguridad.	interrupteur Général de sécurité	General safety switch	Sicherheitshauptschalter	Interruttore Generale di sicurezza
Ides =	Intruptor de desequilibrio.	Interrupteur de balourd	Unbalance switch	Ungleichgewichtsschalter	Interruttore di squilibrio
IMo =	Interruptor Monedero.	Interrupteur Monnayeur	Coin slot switch	Münzschalter	Interruttore Portamonete
Ip =	Interruptor puerta Cerrada.	Interrupteur porte Fermée	Closed door switch	Schalter Tür geschlossen	Interruttore porta Chiusa
Ipb =	Interruptor puerta bloqueada.	Interrupteur porte verrouillée	Door lock switch	Schalter Tür verriegelt	Interruttore porta bloccata
Isc	Interruptor seguridad Temperatura	Thermostat Limiteur	Hi-limit Thermostat	Grenzthermostat	Termostato Limitatore
M =	Motor.	Moteur	Motor	Motor	Motore
Mo =	Monedero.	Monnayeur	Coin slot	Münzvorrichtung	Portamonete
NTC =	Sensor temperatura..	Capteur température	Temperature sensor	Temperatursensor	Sensore temperatura
RT =	Resistencia Calentamiento.	Résistance Chauffe	Heating Resistors	Widerstand Aufheizung	Resistenza Riscaldamento
Tm =	Térmico de Motor.	Thermique du Moteur	Motor hot-wire	Motorwärmeschalter	Termico del Motore
Tfr =	Transformador	Transformateur	Transformer	Transformator	Trasformatore
Tfr s/N =	Transformador Versión sin Neutro.	Transformateur Version sans Neutre	Transformer Version without Neutral	Transformator Modell ohne Neutralstellung	Trasformatore Versione senza Neutro
VAC =	Válvula Vaciado	Vanne Vidange	Emptying valve	Ablassventil	Valvola Scarico
Ve =	Ventilador.	Ventilateur	Fan	Ventilator	Ventola
VF =	Convertidor de Frecuencia.	Convertisseur de Fréquence	Frequency converter	Frequenzumwandler	Convertitore di Frequenza
VM =	Ventilador Motor.	Ventilateur Moteur	Fan motor	Ventilator Motor	Ventola Motore
1...8 =	Puntos conexión dosificadores.	Points raccordement doseurs	Feeder connection points	Anschlussstellen Dosiervorrichtungen	Punti connessione dosatori
<b>COLOR</b>	<b>COLORES</b>	<b>COULEURS</b>	<b>COLOUR</b>	<b>FARBEN</b>	<b>COLORE</b>
a =	Azul	Bleu	Blue	Blau	Blu
am =	Amarillo	Jaune	Yellow	Gelb	Giallo
am/ve =	Amarillo/Verde	Jaune / vert	Yellow / green	Gelb/grun	Giallo/verde
b =	Blanco	Blanc	White	Weiß	Bianco
g =	Gris	Gris	Grey	Grau	Grigio
m =	Marrón	Marron	Brown	Braun	Marrone
n =	Negro	Noir	Black	Schwarz	Nero
na =	Naranja	Orange	Orange	Orange	Arancio
r =	Rojo	Rouge	Red	Rot	Rosso
rs =	Rosa	Rose	Pink	Rosa	Roseo
ve =	Verde	Vert	Green	Grün	Verde
vi =	Violeta	Violet	Purple	Violett	Viola