

DESPIECES

MESAS MSP-CAJONES

SNACK



Rev.: Feb-2011

RECAMBIOS
MESAS
MSP-SNACK
CAJONES
FEB-2011



MODELOS

MSP-150-2C	MSP-150-4C	MSP-200-2C	MSP-200-4C	MSP-200-6C	MSP-250-2C	MSP-250-4C	MSP-250-6C	MSP-250-8C	MSP-300-2C	MSP-300-4C	MSP-300-8C	MSP-117-R2C	MSP-117-R4C	MSP-169-R2C	MSP-169-R4C	MSP-169-R6C	MSP-222-R2C	MSP-222-R4C	MSP-222-R6C	MSP-222-R8C	MSP-274-R6C	MSP-274-R10C
------------	------------	------------	------------	------------	------------	------------	------------	------------	------------	------------	------------	-------------	-------------	-------------	-------------	-------------	-------------	-------------	-------------	-------------	-------------	--------------

Nº	CÓDIGO	DESCRIPCIÓN	MSP-150-2C	MSP-150-4C	MSP-200-2C	MSP-200-4C	MSP-200-6C	MSP-250-2C	MSP-250-4C	MSP-250-6C	MSP-250-8C	MSP-300-2C	MSP-300-4C	MSP-300-8C	MSP-117-R2C	MSP-117-R4C	MSP-169-R2C	MSP-169-R4C	MSP-169-R6C	MSP-222-R2C	MSP-222-R4C	MSP-222-R6C	MSP-222-R8C	MSP-274-R6C	MSP-274-R10C
1	6003010326	DESAG COMPL 3/4 GRIS+TUERCA	1	1	1	1	1	1	1	1	1	1	1	1	1	1	1	1	1	1	1	1	1	1	
2	6003010262	TAPON DESAGÜE DE 3/4 CIEGO	1	1	1	1	1	1	1	1	1	1	1	1	1	1	1	1	1	1	1	1	1	1	
3	6003010327	JUNTA GOMA DESAGÜE 3/4	1	1	1	1	1	1	1	1	1	1	1	1	1	1	1	1	1	1	1	1	1	1	
4	M181010393	ENCIM.MSP-150 PETO	1	1																					
4	M181010394	ENCIM.MSP-200 PETO			1	1	1																		
4	M181010395	ENCIM.MSP-250 TAPET.ZAMAK						1	1	1	1														
4	M181010399	ENCIM.MSP-300										1	1	1											
4	M181010405	ENCIM.MSP-117-R C/PETO													1	1									
4	M181010445	ENCIM.MSP-169-R C/PETO															1	1	1						
4	M181010407	ENCIM.MSP-222-R C/PETO																		1	1	1	1		
4	M181010409	ENCIM.MSP-274-R																						1	1
5	M109170858	PROT.TRAS.ENC.MSP-150	1	1																					
5	M109170859	PROT.TRAS.ENC.MSP-200			1	1	1	1	1	1	1	1	1	1											
5	M109170862	PROT.TRAS.ENC.MSP-117													1	1									
5	M109170863	PROT.TRAS.ENC.MSP-169															1	1	1	1	1	1	1	1	
6	6033090086	JUEGO TAPETAS ENCIM.ZAMAK	1	1	1	1	1	1	1	1	1	1	1	1	1	1	1	1	1	1	1	1	1	1	
7	M109170860	PROT.TRAS.ENC.MSP-250-222 SUPL						1	1	1	1									1	1	1	1		
7	M109170861	PROT.TRAS.ENC.MSP-300-274 SUPL										1	1	1										1	1
9	6007050017	PATA REGULAB ARM GASTRO	4	4	4	4	4	6	6	6	6	6	6	6	4	4	4	4	4	6	6	6	6	6	6
10	M169010088	PUE MSP/MSN AP.IZDA	1		2	1		3	2	1		4	3	1	1		2	1		3	2	1		2	
11	6045010115	BURLETE 465X585 UR-260 MSP	1		2	1		3	2	1		4	3	1	1		2	1		3	2	1		2	
12	6003010136	CAJA ALOJAMIENTO MUELLE GRIS	1		2	1		3	2	1		4	3	1	1		2	1		3	2	1		2	
13	6033010100	BIS.TRS1D DOBL MUELLE DV-2608	1		2	1		3	2	1		4	3	1	1		2	1		3	2	1		2	
14	6033010129	SOP.BISAG.INF.IZD.	1		2	1		3	2	1		4	3	1	1		2	1		3	2	1		2	
15	6033090104	EJE ROSCA EXT.30X10INOX MESAS	1		2	1		3	2	1		4	3	1	1		2	1		3	2	1		2	
16	6025130045	TUERC.RAPIDA TRT M6-2	1		2	1		3	2	1		4	3	1	1		2	1		3	2	1		2	
17	M109050260	SOPOR.SUP.PUERTAS MSP-150	1	1																					
17	M109050266	SOP.SUP.PUER.MSP20-25-30			1	1	1					1	1	1											
17	M109050269	SOP.SUP.PUERT.MSP-250						1	1	1	1														
17	M109050529	SOP.SUP.PUERTAS MSP-117-R													1	1									
17	M109050372	SOP.SUP.PUERTAS MSP-169-R															1	1	1						
17	M109050373	SOPORT.SUP.PUER.MSP-222-R																		1	1	1	1		
17	M109050374	SOP.SUP.PUERTAS MSP274R																						1	1
18	M109050272	SOPORT.SUP.PUERTAS MSP300										1	1	1											
20	M177010065	CHAP.CUAD.MANDOS	1	1	1	1	1	1	1	1	1	1	1	1											
20	M109010642	CUADRO MANDOS MSP-R													1	1	1	1	1	1	1	1	1	1	
21	M109050532	PROTECC.INST.ELECT.FAGOR	1	1	1	1	1	1	1	1	1	1	1	1											
22	6033090090	SOPORTE ZAMAK GIRO REJILLA	1	1	1	1	1	1	1	1	1	1	1	1											
23	6033090104	EJE ROSCA EXT.30X10INOX MESAS	1	1	1	1	1	1	1	1	1	1	1	1											
24	6023010408	PEG.CUAD.FAGOR REFR.347.5X60	1	1	1	1	1	1	1	1	1	1	1	1											
24	6023010418	PEG.105X220 CUADR.REMOT FAGOR													1	1	1	1	1	1	1	1	1	1	
25	6021130001	INT.BIP.AMB.O/I CONTAC.REFORZ.	1	1	1	1	1	1	1	1	1	1	1	1	1	1	1	1	1	1	1	1	1	1	
26	6021350018	TERMOS REFRI CAREL PYCO1RN515	1	1	1	1	1	1	1	1	1	1	1	1	1	1	1	1	1	1	1	1	1	1	
27	6021130010	PILOTO RECTAN.AMBAR LUM.FAGOR													1	1	1	1	1	1	1	1	1	1	
30	6021010004	COMPR.FR-7,5-G R134A	1	1																					
30	6021010007	COMPR.FR-8,5-G R134A			1	1	1																		
30	6021010154	COMP.NEK6210Z EMBRACO						1	1	1	1	1	1	1											
31	6029020002	CONDENSADOR 9x2	1	1	1	1	1																		
31	6029020003	CONDENSADOR 9x3 FAGC0021						1	1	1	1	1	1	1											
32	6021050002	VENTILADOR 10W PATA PALA 220V	1	1	1	1	1	1	1	1	1	1	1	1											
33	6021310003	VALVULA OBUS COMPLETA RF.HB-1S	1	1	1	1	1	1	1	1	1	1	1	1											
34	6047010003	FILTRO DESHIDRAT.40GR 1/4X1/4	1	1	1	1	1	1	1	1	1	1	1	1											
35	M107010037	SERP.EV.AUTOM.1/4 PINT.150,200	1	1	1	1	1	1	1	1	1	1	1	1											
36	6003010023	BANDEJA EVAPORACION AUTOMÁTICA	1	1	1	1	1	1	1	1	1	1	1	1											
37	M109250127	OMEGA COND.9X2-REJ.MESAS-ARMAR	1	1	1	1	1	1	1	1	1	1	1	1											
40	M171010108	UD.EV.MSP150,200,135,180 COMP.	1	1	1	1	1																		
40	M171010109	UD.EV. MSP250,300,225,270 COMP						1	1	1	1	1	1	1											
40	M171010113	UD.EV. MSP-117,102,169-R COMP.													1	1	1	1	1						
40	M171010116	EV.MSP-222,274																		1	1	1	1	1	

RECAMBIOS
MESAS
MSP-SNACK
CAJONES
FEB-2011



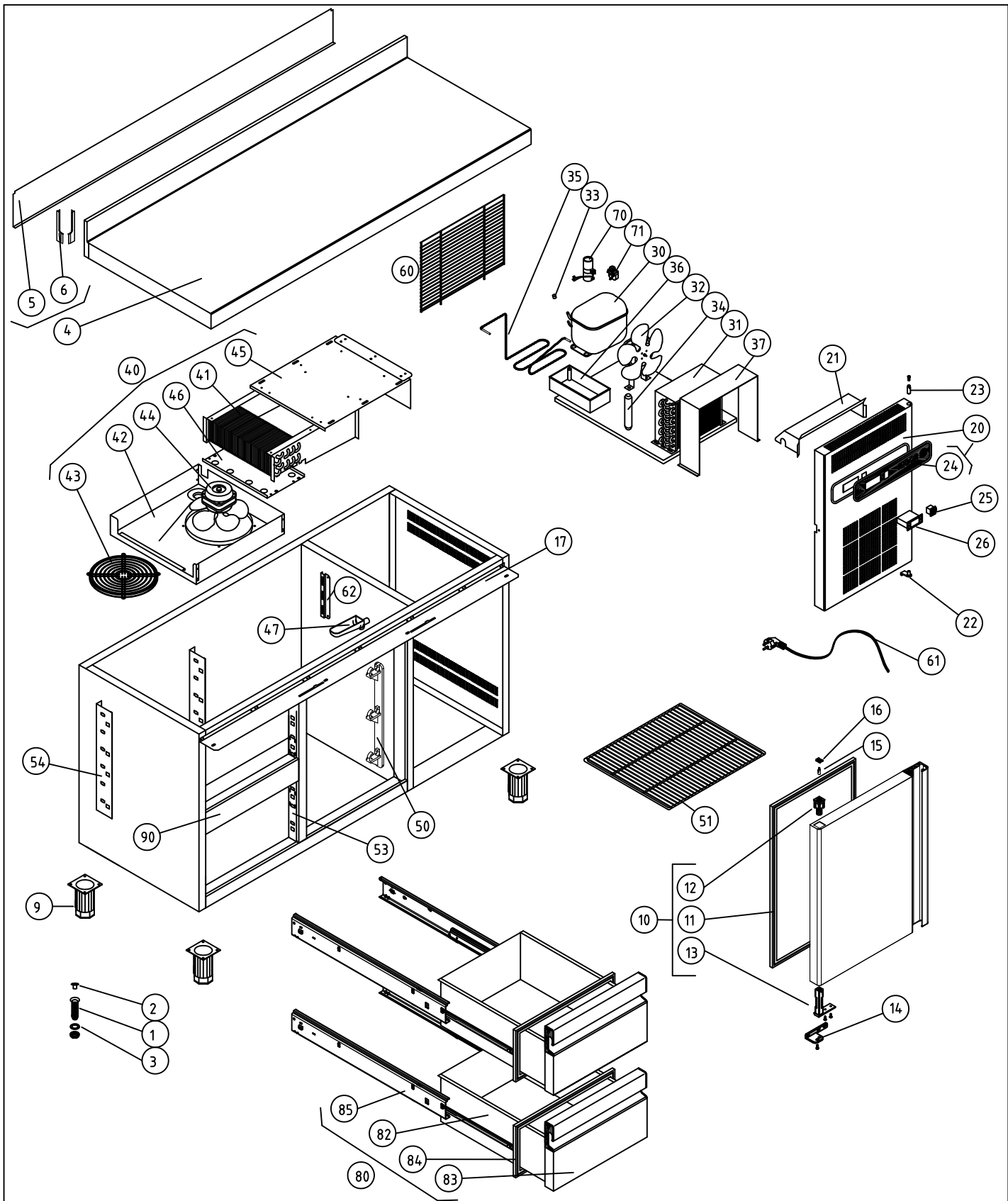

MODELOS

Nº	CÓDIGO	DESCRIPCIÓN	MSP-150-2C	MSP-150-4C	MSP-200-2C	MSP-200-4C	MSP-200-6C	MSP-250-2C	MSP-250-4C	MSP-250-6C	MSP-250-8C	MSP-300-2C	MSP-300-4C	MSP-300-8C	MSP-117-R2C	MSP-117-R4C	MSP-169-R2C	MSP-169-R4C	MSP-169-R6C	MSP-222-R2C	MSP-222-R4C	MSP-222-R6C	MSP-274-R8C	MSP-274-R6C	MSP-274-R10C	
41	6029010151	BAT.5T4R300A4S PINT.MESAS	1	1	1	1	1								1	1	1	1	1							
41	6029010150	BAT 6T4R300A4S PINT.MESAS						1	1	1	1	1	1	1							1	1	1	1	1	1
42	M109250148	SUJ.VENTIL.MSP-150,200 COMPACT	1	1	1	1	1	1	1	1	1	1	1	1	1	1	1	1	1	1	1	1	1	1	1	1
43	6027130004	REJILLA VENT.D.246 PINTADA	1	1	1	1	1	1	1	1	1	1	1	1	1	1	1	1	1	1	1	1	1	1	1	1
44	6021050066	VENTIL.EVAPOR.5W S/ARO S/PATAS	1	1	1	1	1	1	1	1	1	1	1	1	1	1	1	1	1	1	1	1	1	1	1	1
45	M109250151	SOP.EVAP.MESAS EVAP.COMPACTO	1	1	1	1	1	1	1	1	1	1	1	1	1	1	1	1	1	1	1	1	1	1	1	1
46	M109250150	CUBRER.BAT.6T4R300A6S EVAP.COM	1	1	1	1	1	1	1	1	1	1	1	1	1	1	1	1	1	1	1	1	1	1	1	1
47	6003010184	CANALIZAD.AGUA 150 GRIS REFRIG	1	1	1	1	1	1	1	1	1	1	1	1	1	1	1	1	1	1	1	1	1	1	1	1
50	6003010377	SOPORT.PARRILA 3NIVELES	4		8	4		12	8	4		16	12	4	4		8	4		12	8	4		8		
51	6027010079	PARRIL.405X460 EXTREM.MSP	1		1	1		1	1	1		1	1	1	1		1	1		1	1	1		1		
52	6027010078	PARRIL 405X525 CENTRO MSP			1			2	1			3	2				1			2	1			1		
53	M109050747	CREM. MARC. MAGNETICO MSP-MFP	2	4	2	4	6	2	4	6	8	2	4	8	2	4	2	4	6	2	4	6	8	6	10	
54	M109050278	CREM.IZD.RESP.MSP-CAJ	2	2	2	3	3	2	3	3	4	2	3	5	2	2	2	3	3	2	3	4	4	4	5	
55	M109050279	CREM.DCH.RESP.MSP-CAJ				1	1		1	3	2		1	3				1	1		1	2	2	2	3	
56	M109050280	CREM.DCHA.LAD.GRUP.MSP CAJ		2			2				2				2			2					2		2	
60	6003010181	REJ.RESP.GRUPO 387X280POLICARB	1	1	1	1	1	1	1	1	1	1	1	1												
61	6021390006	MANG 3X1X2500 BL. SCHUKO 3T	1	1	1	1	1	1	1	1	1	1	1	1	1	1	1	1	1	1	1	1	1	1	1	1
62	M109050033	PROT SONDA 175x49	1	1	1	1	1	1	1	1	1	1	1	1	1	1	1	1	1	1	1	1	1	1	1	1
70	6021010037	CONDEN.ARRANQUE FR-117U5015 80 mF	1	1	1	1	1																			
70	6021010158	CONDENSADOR COMP. NEK 6210Z						1	1	1	1	1	1	1												
71	6021010045	RELE ARRANQ COMPR.FR-7.5G 6001	1	1																						
71	6021010025	RELE ARRANQUE COMPRESOR FR-8.5G 2			1	1	1																			
71	6021010156	RELE ARRAN. COMP. NEK 6210Z						1	1	1	1	1	1	1												
80	M169120097	CAJÓN MSP 1/2 GAMA	2	3	2	4	5	2	4	6	7	2	4	8	2	3	2	4	5	2	4	6	7	6	9	
81	M169120099	CAJÓN MSP 1/2LAD.GRUPO		1			1				1					1			1				1		1	
82	M109050066	CAJON SNACK 1/2 190 prof	2	3	2	4	5	2	4	6	7	2	4	8	2	3	2	4	5	2	4	6	7	6	9	
83	M169120098	FRENTE CAJÓN MSP 1/2	2	4	2	4	6	2	4	6	8	2	4	8	2	4	2	4	6	2	4	6	8	6	10	
84	6045010118	BURLET 465x265 CAJ.1/2 MSP	2	4	2	4	6	2	4	6	8	2	4	8	2	4	2	4	6	2	4	6	8	6	10	
85	6033050007	GUIA DE ACERO L450 BRILLO(JGO)	2	4	2	4	6	2	4	6	8	2	4	8	2	4	2	4	6	2	4	6	8	6	10	
86	M109050067	CAJON SNACK 1/3 90 prof.		1			1				1					1			1				1		1	
90	M161130005	FRONTI POSTIZO MSP CAJ MAGNETI	1	2	1	2	3	1	2	3	4	1	2	4	1	2	1	2	3	1	2	3	4	3	5	

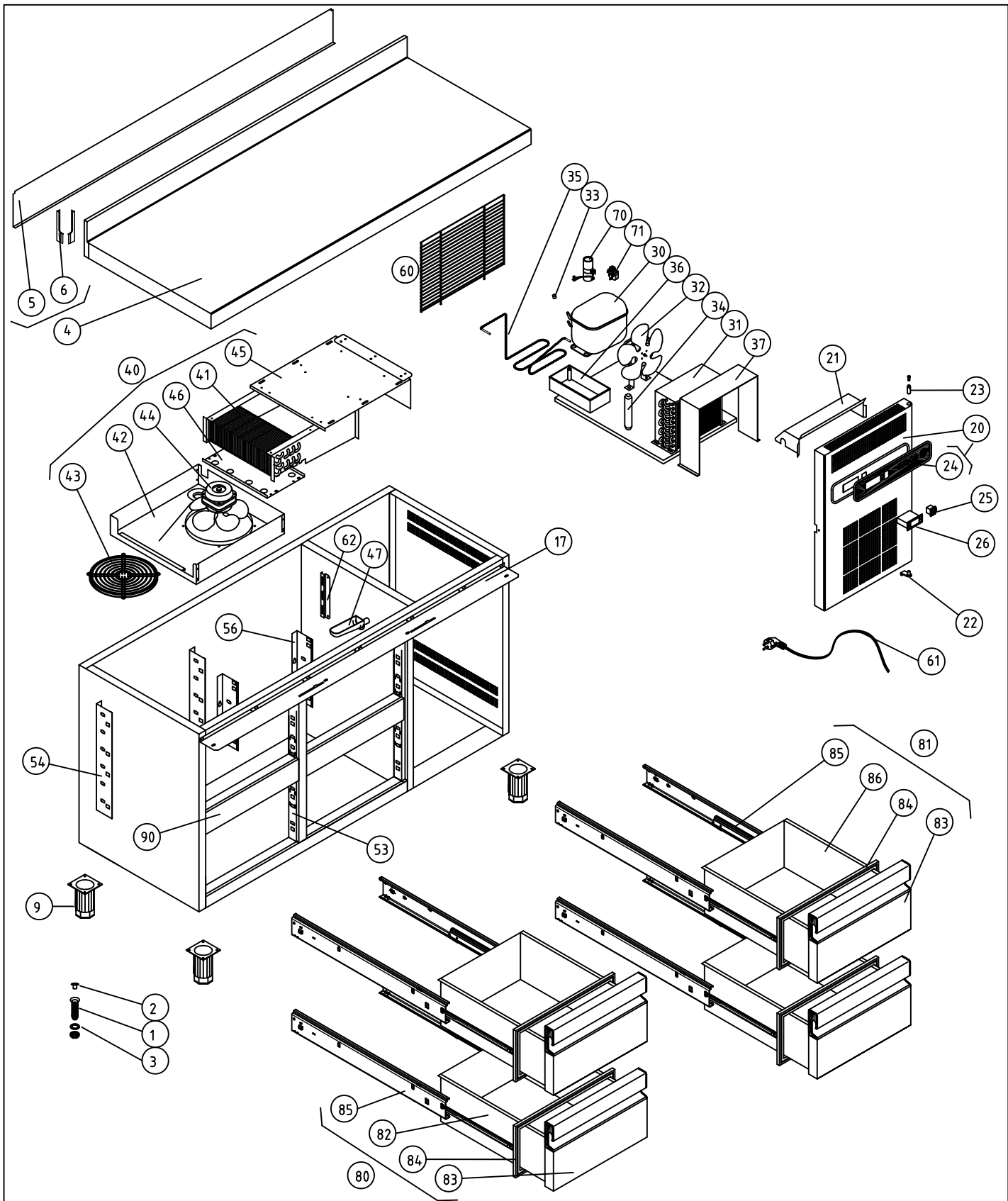

M1 MESAS FRÍAS				COD. PIEZA: 148111120000									
COTAS SIN TOLERANCIA DIN 7168-f				Material: MATERIAL ESPESOR									
				Acabado: ACABADO									
ANGULAR	GRADO TOLERANCIA	FINO	MEDIO	GRUESO									
	HASTA 10 mm		±1°	±1° 30'									
	MAS DE 10 A 50 mm		±30'	±50'									
	MAS DE 50 A 120 mm		±20'	±25'									
COMUN A	MAS DE 120 A 400 mm		±10'	±15'	MODELO	Ud.	MODELO	Ud.	MODELO	Ud.	MODELO	Ud.	
	MAS DE 400 mm		±5'	±10'	MSP-150-2C	1							
LINEAL	GRADO TOLERANCIA	FINO	MEDIO	GRUESO	A4		Nombre		Fecha				
	HASTA 3 mm		±0,05	±0,10	±0,15	Dibujado		A.J.GONZALEZ		Feb-2011			
	MAS DE 3 A 6 mm		±0,05	±0,10	±0,20	Modificado							
	MAS DE 6 A 30 mm		±0,10	±0,20	±0,50	Escala		1:22		FAGOR  F A G O F R I Código máquina: CODIGO			
	MAS DE 30 A 120 mm		±0,15	±0,30	±0,80								
	MAS DE 120 A 400 mm		±0,20	±0,50	±1,20								
MAS DE 400 A 1000 mm		±0,30	±0,80	±2,00									
MAS DE 1000 A 2000 mm		±0,50	±1,20	±3,00									



M1 MESAS FRÍAS				COD. PIEZA: 148111140000																																																															
COTAS SIN TOLERANCIA DIN 7168-f				Material: MATERIAL ESPESOR																																																															
<table border="1"> <thead> <tr> <th>GRADO TOLERANCIA</th> <th>FINO</th> <th>MEDIO</th> <th>GRUESO</th> </tr> </thead> <tbody> <tr> <td>HASTA 10 mm</td> <td></td> <td>±1°</td> <td>±1° 30'</td> </tr> <tr> <td>MAS DE 10 A 50 mm</td> <td></td> <td>±30'</td> <td>±50'</td> </tr> <tr> <td>MAS DE 50 A 120 mm</td> <td></td> <td>±20'</td> <td>±25'</td> </tr> <tr> <td>MAS DE 120 A 400 mm</td> <td></td> <td>±10'</td> <td>±15'</td> </tr> <tr> <td>MAS DE 400 mm</td> <td></td> <td>±5'</td> <td>±10'</td> </tr> </tbody> </table>				GRADO TOLERANCIA	FINO	MEDIO	GRUESO	HASTA 10 mm		±1°	±1° 30'	MAS DE 10 A 50 mm		±30'	±50'	MAS DE 50 A 120 mm		±20'	±25'	MAS DE 120 A 400 mm		±10'	±15'	MAS DE 400 mm		±5'	±10'	Acabado: ACABADO																																							
GRADO TOLERANCIA	FINO	MEDIO	GRUESO																																																																
HASTA 10 mm		±1°	±1° 30'																																																																
MAS DE 10 A 50 mm		±30'	±50'																																																																
MAS DE 50 A 120 mm		±20'	±25'																																																																
MAS DE 120 A 400 mm		±10'	±15'																																																																
MAS DE 400 mm		±5'	±10'																																																																
<table border="1"> <thead> <tr> <th>ANGULAR</th> <th>GRADO TOLERANCIA</th> <th>FINO</th> <th>MEDIO</th> <th>GRUESO</th> </tr> </thead> <tbody> <tr> <td></td> <td>HASTA 3 mm</td> <td>±0,05</td> <td>±0,10</td> <td>±0,15</td> </tr> <tr> <td></td> <td>MAS DE 3 A 6 mm</td> <td>±0,05</td> <td>±0,10</td> <td>±0,20</td> </tr> <tr> <td></td> <td>MAS DE 6 A 30 mm</td> <td>±0,10</td> <td>±0,20</td> <td>±0,50</td> </tr> <tr> <td></td> <td>MAS DE 30 A 120 mm</td> <td>±0,15</td> <td>±0,30</td> <td>±0,80</td> </tr> <tr> <td></td> <td>MAS DE 120 A 400 mm</td> <td>±0,20</td> <td>±0,50</td> <td>±1,20</td> </tr> <tr> <td></td> <td>MAS DE 400 A 1000 mm</td> <td>±0,30</td> <td>±0,80</td> <td>±2,00</td> </tr> <tr> <td></td> <td>MAS DE 1000 A 2000 mm</td> <td>±0,50</td> <td>±1,20</td> <td>±3,00</td> </tr> </tbody> </table>				ANGULAR	GRADO TOLERANCIA	FINO	MEDIO	GRUESO		HASTA 3 mm	±0,05	±0,10	±0,15		MAS DE 3 A 6 mm	±0,05	±0,10	±0,20		MAS DE 6 A 30 mm	±0,10	±0,20	±0,50		MAS DE 30 A 120 mm	±0,15	±0,30	±0,80		MAS DE 120 A 400 mm	±0,20	±0,50	±1,20		MAS DE 400 A 1000 mm	±0,30	±0,80	±2,00		MAS DE 1000 A 2000 mm	±0,50	±1,20	±3,00	<table border="1"> <thead> <tr> <th>COMUN A</th> <th>MODELO</th> <th>Ud.</th> <th>MODELO</th> <th>Ud.</th> <th>MODELO</th> <th>Ud.</th> <th>MODELO</th> <th>Ud.</th> <th>MODELO</th> </tr> </thead> <tbody> <tr> <td></td> <td>MSP-150-4C</td> <td>1</td> <td></td> <td></td> <td></td> <td></td> <td></td> <td></td> <td></td> </tr> </tbody> </table>				COMUN A	MODELO	Ud.	MODELO	Ud.	MODELO	Ud.	MODELO	Ud.	MODELO		MSP-150-4C	1							
ANGULAR	GRADO TOLERANCIA	FINO	MEDIO	GRUESO																																																															
	HASTA 3 mm	±0,05	±0,10	±0,15																																																															
	MAS DE 3 A 6 mm	±0,05	±0,10	±0,20																																																															
	MAS DE 6 A 30 mm	±0,10	±0,20	±0,50																																																															
	MAS DE 30 A 120 mm	±0,15	±0,30	±0,80																																																															
	MAS DE 120 A 400 mm	±0,20	±0,50	±1,20																																																															
	MAS DE 400 A 1000 mm	±0,30	±0,80	±2,00																																																															
	MAS DE 1000 A 2000 mm	±0,50	±1,20	±3,00																																																															
COMUN A	MODELO	Ud.	MODELO	Ud.	MODELO	Ud.	MODELO	Ud.	MODELO																																																										
	MSP-150-4C	1																																																																	
<table border="1"> <thead> <tr> <th>LINEAL</th> <th>GRADO TOLERANCIA</th> <th>FINO</th> <th>MEDIO</th> <th>GRUESO</th> </tr> </thead> <tbody> <tr> <td></td> <td>HASTA 3 mm</td> <td>±0,05</td> <td>±0,10</td> <td>±0,15</td> </tr> <tr> <td></td> <td>MAS DE 3 A 6 mm</td> <td>±0,05</td> <td>±0,10</td> <td>±0,20</td> </tr> <tr> <td></td> <td>MAS DE 6 A 30 mm</td> <td>±0,10</td> <td>±0,20</td> <td>±0,50</td> </tr> <tr> <td></td> <td>MAS DE 30 A 120 mm</td> <td>±0,15</td> <td>±0,30</td> <td>±0,80</td> </tr> <tr> <td></td> <td>MAS DE 120 A 400 mm</td> <td>±0,20</td> <td>±0,50</td> <td>±1,20</td> </tr> <tr> <td></td> <td>MAS DE 400 A 1000 mm</td> <td>±0,30</td> <td>±0,80</td> <td>±2,00</td> </tr> <tr> <td></td> <td>MAS DE 1000 A 2000 mm</td> <td>±0,50</td> <td>±1,20</td> <td>±3,00</td> </tr> </tbody> </table>				LINEAL	GRADO TOLERANCIA	FINO	MEDIO	GRUESO		HASTA 3 mm	±0,05	±0,10	±0,15		MAS DE 3 A 6 mm	±0,05	±0,10	±0,20		MAS DE 6 A 30 mm	±0,10	±0,20	±0,50		MAS DE 30 A 120 mm	±0,15	±0,30	±0,80		MAS DE 120 A 400 mm	±0,20	±0,50	±1,20		MAS DE 400 A 1000 mm	±0,30	±0,80	±2,00		MAS DE 1000 A 2000 mm	±0,50	±1,20	±3,00	A4		Nombre		Fecha																			
LINEAL	GRADO TOLERANCIA	FINO	MEDIO	GRUESO																																																															
	HASTA 3 mm	±0,05	±0,10	±0,15																																																															
	MAS DE 3 A 6 mm	±0,05	±0,10	±0,20																																																															
	MAS DE 6 A 30 mm	±0,10	±0,20	±0,50																																																															
	MAS DE 30 A 120 mm	±0,15	±0,30	±0,80																																																															
	MAS DE 120 A 400 mm	±0,20	±0,50	±1,20																																																															
	MAS DE 400 A 1000 mm	±0,30	±0,80	±2,00																																																															
	MAS DE 1000 A 2000 mm	±0,50	±1,20	±3,00																																																															
Dibujado		A.J.GONZALEZ		Feb-2011		 F A G O F R I																																																													
Modificado																																																																			
Escala		1:22		RECAMBIOS MSP-150-4C				Código máquina: CODIGO																																																											

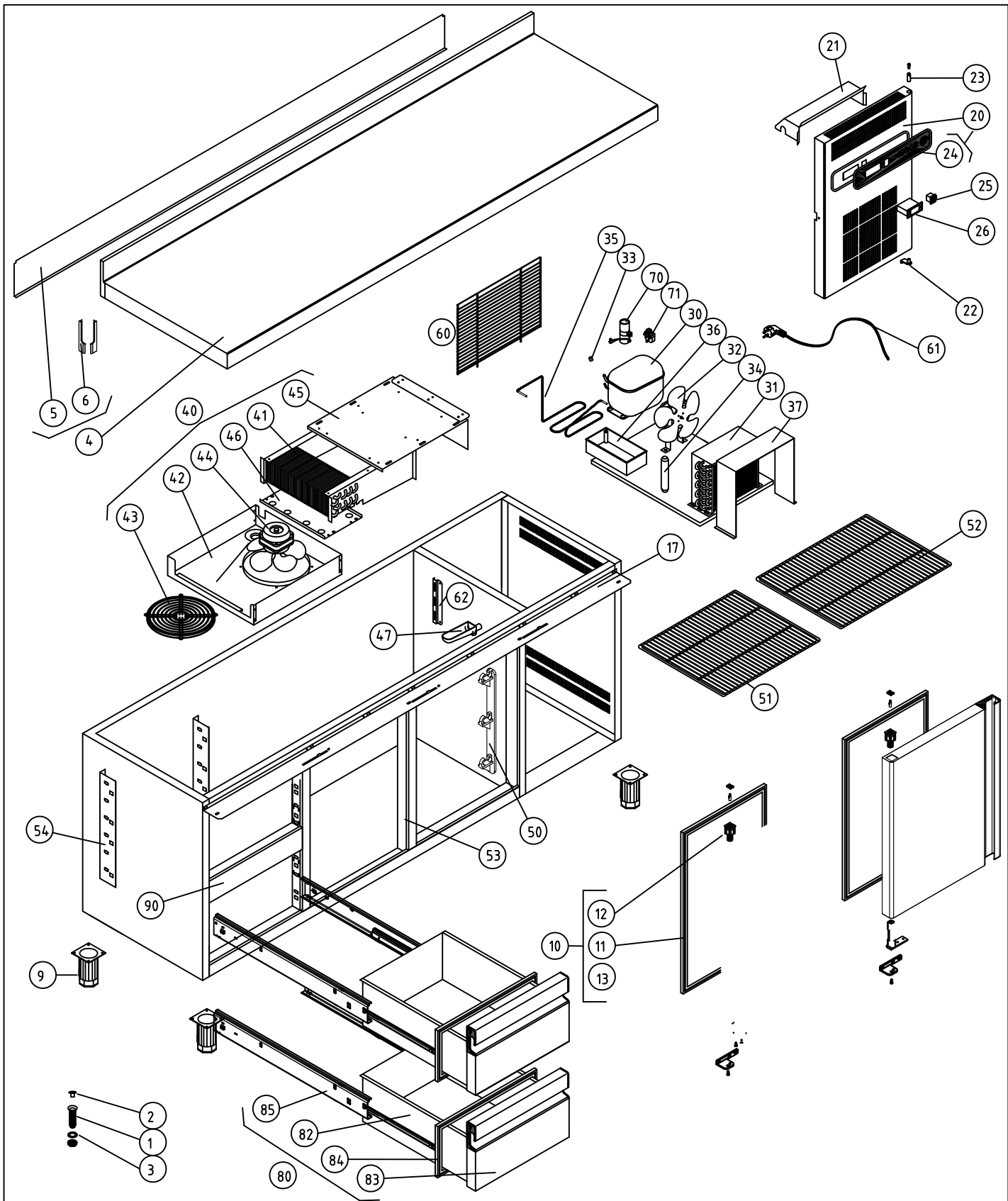

M1 MESAS FRÍAS				COD. 148111220000				
COTAS SIN TOLERANCIA DIN 7168-f				Material: MATERIAL ESPESOR				
				Acabado: ACABADO				
ANGULAR	GRADO TOLERANCIA	FINO	MEDIO	GRUESO	SUSTITUYE A:			
	HASTA 10 mm		±1°	±1° 30'	SUSTITUIDO POR:			
	MAS DE 10 A 50 mm		±30'	±50'	MODELO	Ud.	MODELO	Ud.
	MAS DE 50 A 120 mm		±20'	±25'	MSP-200-2C	1		
MAS DE 120 A 400 mm		±10'	±15'					
MAS DE 400 mm		±5'	±10'					
LINEAL	GRADO TOLERANCIA	FINO	MEDIO	GRUESO	A4			Nombre
	HASTA 3 mm	±0,05	±0,10	±0,15	Dibujado			A.J.GONZALEZ
	MAS DE 3 A 6 mm	±0,05	±0,10	±0,20	Modificado			Fecha
	MAS DE 6 A 30 mm	±0,10	±0,20	±0,50	Escala			Feb-2011
	MAS DE 30 A 120 mm	±0,15	±0,30	±0,80	1:22			
	MAS DE 120 A 400 mm	±0,20	±0,50	±1,20	RECAMBIOS MSP-200-2C			Código máquina:
MAS DE 400 A 1000 mm	±0,30	±0,80	±2,00				CODIGO	
MAS DE 1000 A 2000 mm	±0,50	±1,20	±3,00					



F A G O F R I

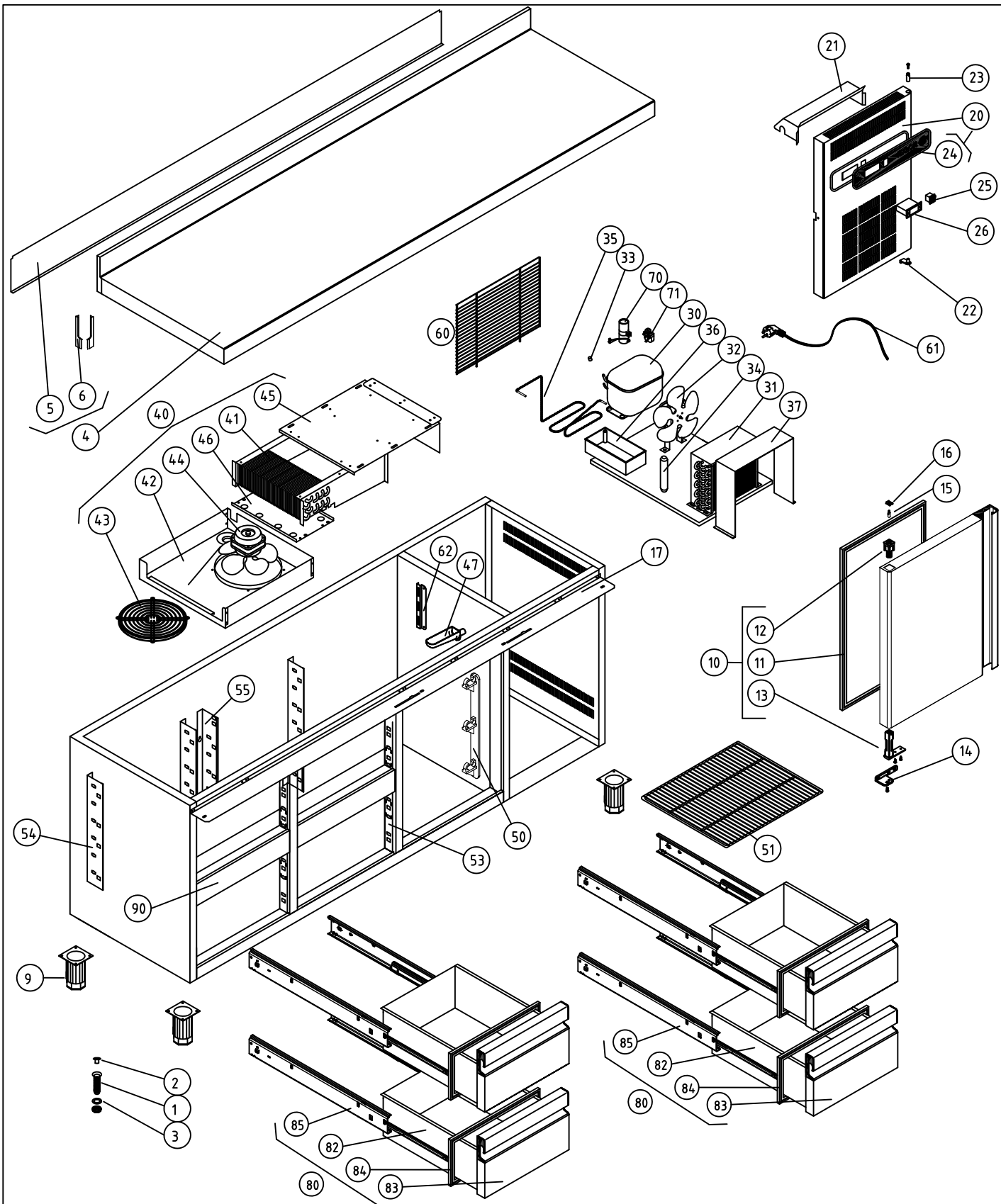

M1 MESAS FRÍAS				COD. 148111240000					
COTAS SIN TOLERANCIA DIN 7168-f				Material: MATERIAL ESPESOR					
				SUSTITUYE A:					
				SUSTITUIDO POR:					
ANGULAR	GRADO TOLERANCIA	FINO	MEDIO	GRUESO					
	HASTA 10 mm		±1°	±1° 30'					
	MAS DE 10 A 50 mm		±30'	±50'					
	MAS DE 50 A 120 mm		±20'	±25'					
	MAS DE 120 A 400 mm		±10'	±15'					
MAS DE 400 mm		±5'	±10'						
LINEAL	GRADO TOLERANCIA	FINO	MEDIO	GRUESO					
	HASTA 3 mm		±0,05	±0,10	±0,15				
	MAS DE 3 A 6 mm		±0,05	±0,10	±0,20				
	MAS DE 6 A 30 mm		±0,10	±0,20	±0,50				
	MAS DE 30 A 120 mm		±0,15	±0,30	±0,80				
MAS DE 120 A 400 mm		±0,20	±0,50	±1,20					
MAS DE 400 A 1000 mm		±0,30	±0,80	±2,00					
MAS DE 1000 A 2000 mm		±0,50	±1,20	±3,00					
Acabado: ACABADO		Material: MATERIAL ESPESOR		SUSTITUYE A:		SUSTITUIDO POR:			
COMUN A	MODELO	Ud.	MODELO	Ud.	MODELO	Ud.	MODELO	Ud.	MODELO
	MSP-200-4C	1							
A4		Nombre		Fecha		 F A G O F R I			
Dibujado		A.J.GONZALEZ		Feb-2011					
Modificado									
Escala		1:22		RECAMBIOS MSP-200-4C				Código máquina:	
								CODIGO	

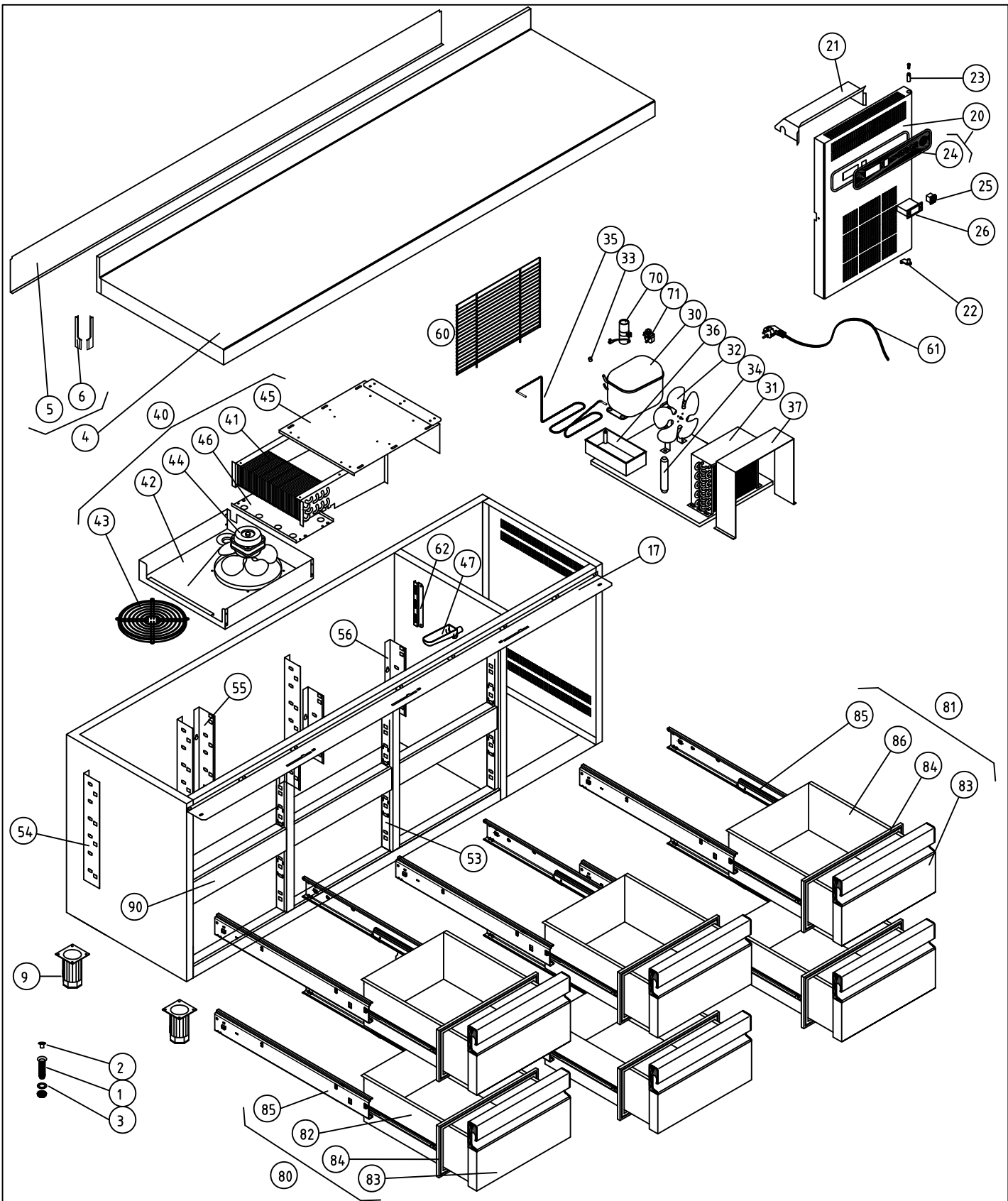

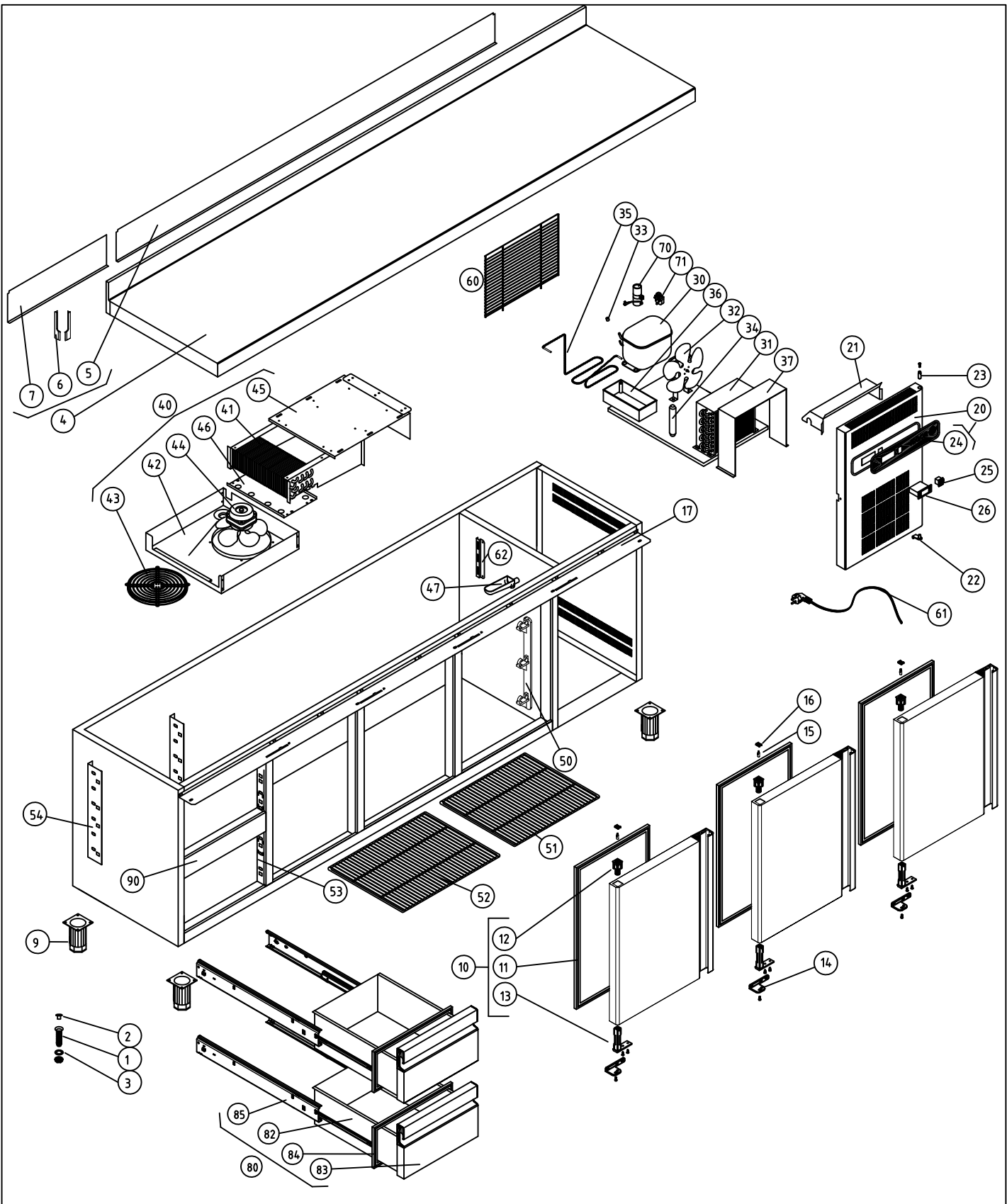

M1 MESAS FRÍAS				COD. 148111260000								
COTAS SIN TOLERANCIA DIN 7168-f				Material: MATERIAL ESPESOR								
SUSTITUYE A:				SUSTITUIDO POR:								
Acabado: ACABADO				COMUN A								
ANGULAR	GRADO TOLERANCIA	FINO	MEDIO	GRUESO	MODELO	Ud.	MODELO	Ud.	MODELO	Ud.	MODELO	Ud.
	HASTA 10 mm		±1°	±1° 30'	MSP-200-6C	1						
	MAS DE 10 A 50 mm		±30'	±50'								
	MAS DE 50 A 120 mm		±20'	±25'								
LINEAL	MAS DE 120 A 400 mm		±10'	±15'								
	MAS DE 400 mm		±5'	±10'								
	GRADO TOLERANCIA	FINO	MEDIO	GRUESO	A4		Nombre		Fecha		 F A G O F R I	
	HASTA 3 mm	±0,05	±0,10	±0,15	Dibujado		A.J.GONZALEZ		Feb-2011			
MAS DE 3 A 6 mm	±0,05	±0,10	±0,20	Modificado								
MAS DE 6 A 30 mm	±0,10	±0,20	±0,50	Escala		1:22		RECAMBIOS MSP-200-6C		Código máquina: CODIGO		
MAS DE 30 A 120 mm	±0,15	±0,30	±0,80									
MAS DE 120 A 400 mm	±0,20	±0,50	±1,20									
MAS DE 400 A 1000 mm	±0,30	±0,80	±2,00									
MAS DE 1000 A 2000 mm	±0,50	±1,20	±3,00									



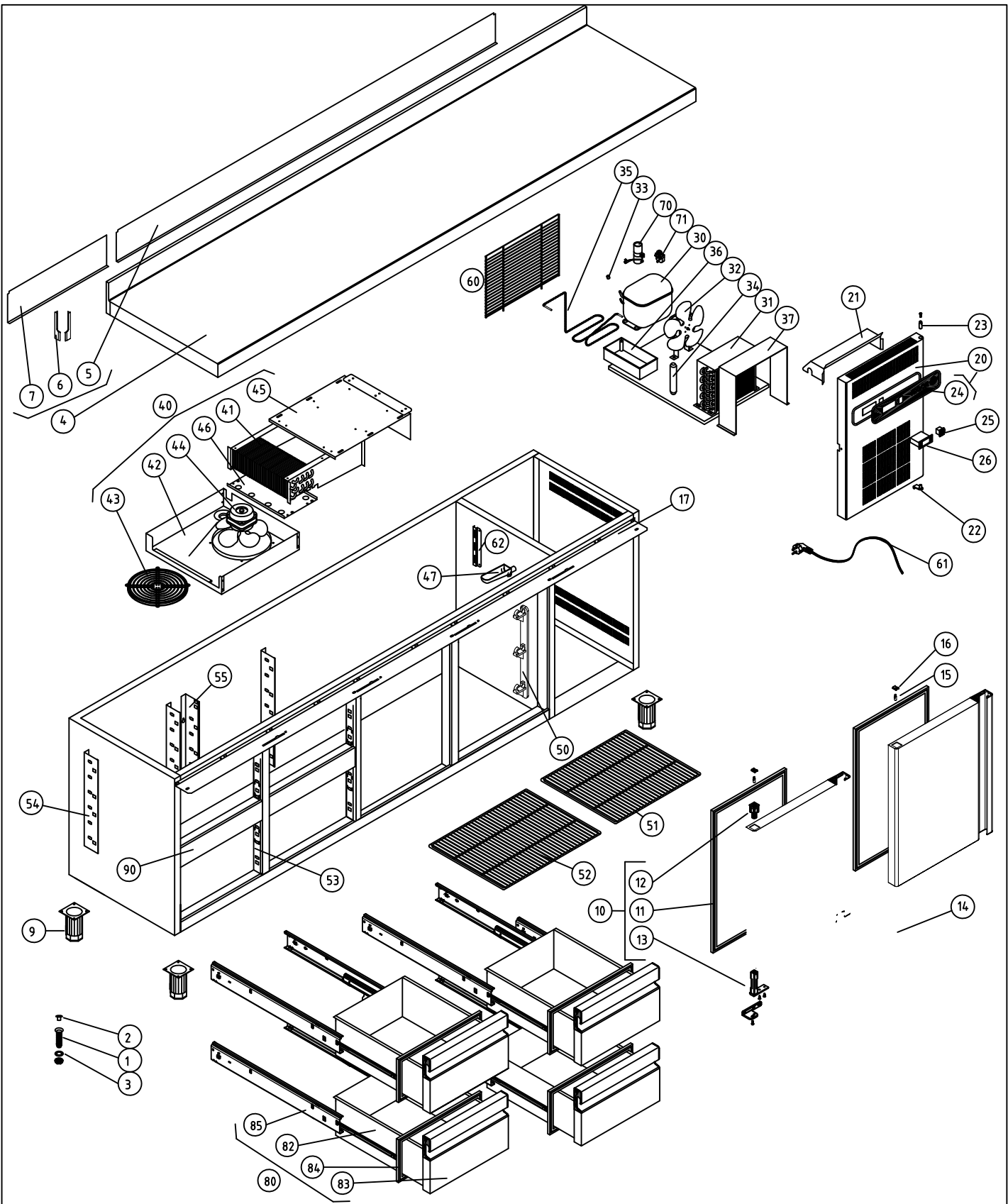

M1 MESAS SNACK					COD. 148111320000									
COTAS SIN TOLERANCIA DIN 7168-f					Material:									
ANGULAR	GRADO TOLERANCIA	FINO	MEDIO	GRUESO	Acabado:									
	HASTA 10 mm		±1°	±1° 30'	SUSTITUYE A:									
	MAS DE 10 A 50 mm		±30'	±50'	SUSTITUIDO POR:									
	MAS DE 50 A 120 mm		±20'	±25'										
LINEAL	MAS DE 120 A 400 mm		±10'	±15'										
	MAS DE 400 mm		±5'	±10'										
	GRADO TOLERANCIA	FINO	MEDIO	GRUESO										
	HASTA 3 mm	±0,05	±0,10	±0,15										
MAS DE 3 A 6 mm	±0,05	±0,10	±0,20											
MAS DE 6 A 30 mm	±0,10	±0,20	±0,50											
MAS DE 30 A 120 mm	±0,15	±0,30	±0,80											
MAS DE 120 A 400 mm	±0,20	±0,50	±1,20											
MAS DE 400 A 1000 mm	±0,30	±0,80	±2,00											
MAS DE 1000 A 2000 mm	±0,50	±1,20	±3,00											
COMUN A					MODELO	Ud.	MODELO	Ud.	MODELO	Ud.	MODELO	Ud.	MODELO	Ud.
					MSP-250-2C	1								
A4					Nombre			Fecha						
Dibujado					A.J.GONZALEZ			Feb-2011						
Modificado														
Escala					1:25			RECAMBIOS MSP-250-2C						
								Código máquina:						



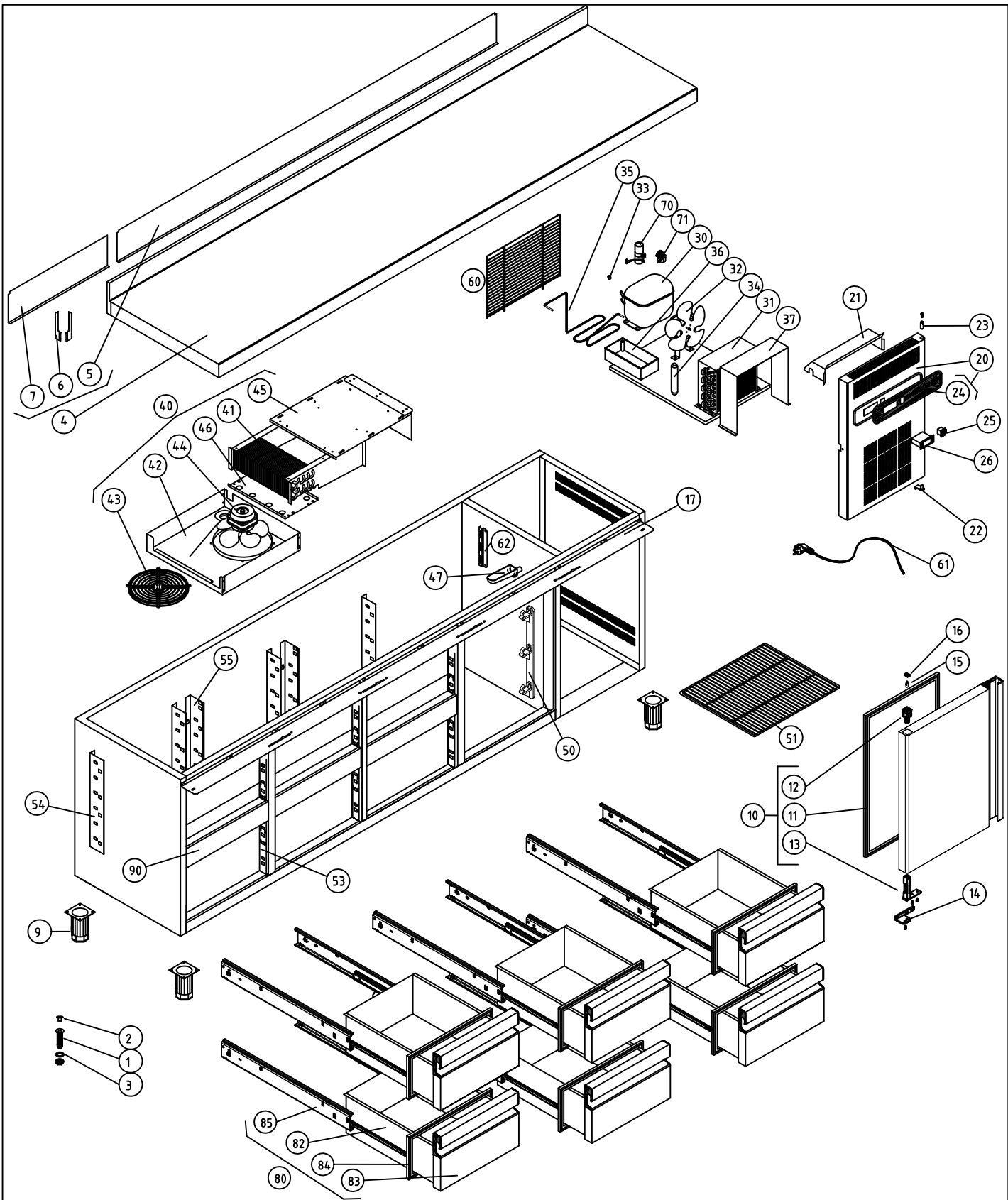

M1 MESAS SNACK					COD. 148111340000				
COTAS SIN TOLERANCIA DIN 7168-f					Material:				
ANGULAR	GRADO TOLERANCIA	FINO	MEDIO	GRUESO	Acabado:				
	HASTA 10 mm		±1°	±1° 30'	SUSTITUYE A:				
	MAS DE 10 A 50 mm		±30'	±50'	SUSTITUIDO POR:				
	MAS DE 50 A 120 mm		±20'	±25'					
LINEAL	MAS DE 120 A 400 mm		±10'	±15'					
	MAS DE 400 mm		±5'	±10'					
	MAS DE 3 mm	±0,05	±0,10	±0,15					
	MAS DE 6 A 30 mm	±0,10	±0,20	±0,50					
COMUN A	MAS DE 30 A 120 mm	±0,15	±0,30	±0,80					
	MAS DE 120 A 400 mm	±0,20	±0,50	±1,20					
	MAS DE 400 A 1000 mm	±0,30	±0,80	±2,00					
	MAS DE 1000 A 2000 mm	±0,50	±1,20	±3,00					
A4		Nombre			Fecha				
Dibujado		A.J.GONZALEZ			Feb-2011				
Modificado									
Escala		1:25			RECAMBIOS MSP-250-4C				
					 F A G O R I				
					Código máquina:				



M1 MESAS SNACK						COD. 148111360000					
COTAS SIN TOLERANCIA DIN 7168-f						Material:					
ANGULAR	GRADO TOLERANCIA	FINO	MEDIO	GRUESO	Acabado:						
	HASTA 10 mm		±1°	±1° 30'	SUSTITUYE A:						
	MAS DE 10 A 50 mm		±30'	±50'	SUSTITUIDO POR:						
	MAS DE 50 A 120 mm		±20'	±25'							
LINEAL	MAS DE 120 A 400 mm		±10'	±15'							
	MAS DE 400 mm		±5'	±10'							
	MAS DE 3 mm		±0,05	±0,10							
	MAS DE 6 A 30 mm		±0,10	±0,20							
COMUN A	MAS DE 30 A 120 mm		±0,15	±0,30							
	MAS DE 120 A 400 mm		±0,20	±0,50							
	MAS DE 400 A 1000 mm		±0,30	±0,80							
	MAS DE 1000 A 2000 mm		±0,50	±3,00							
A4		Nombre		Fecha		 F A G O R I					
Dibujado		A.J.GONZALEZ		Feb-2011							
Modificado											
Escala		1:25		RECAMBIOS MSP-250-6C						Código máquina:	

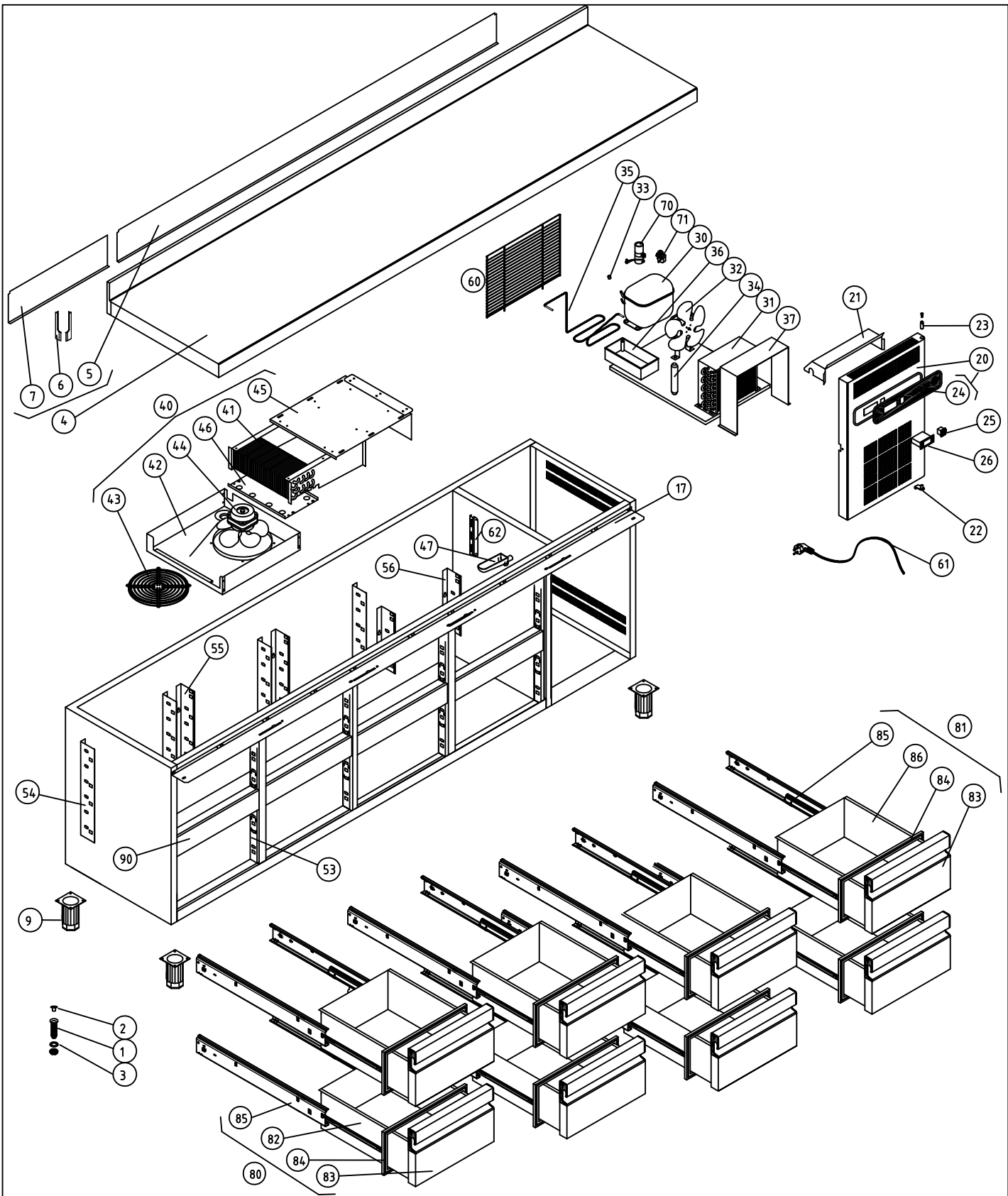

M1 MESAS SNACK						COD. 148111380000						
COTAS SIN TOLERANCIA DIN 7168-f						Material:						
ANGULAR	GRADO TOLERANCIA	FINO	MEDIO	GRUESO	Acabado:							
	HASTA 10 mm		±1°	±1° 30'	SUSTITUYE A:							
	MAS DE 10 A 50 mm		±30'	±50'	SUSTITUIDO POR:							
	MAS DE 50 A 120 mm		±20'	±25'	MODELO	Ud.	MODELO	Ud.	MODELO	Ud.	MODELO	Ud.
	MAS DE 120 A 400 mm		±10'	±15'	MSP-250-8C	1						
MAS DE 400 mm		±5'	±10'	COMUN A								
LINEAL	GRADO TOLERANCIA	FINO	MEDIO	GRUESO	A4		Nombre		Fecha			
	HASTA 3 mm	±0,05	±0,10	±0,15	Dibujado		A.J.GONZALEZ		Feb-2011			
	MAS DE 3 A 6 mm	±0,05	±0,10	±0,20	Modificado							
	MAS DE 6 A 30 mm	±0,10	±0,20	±0,50	Escala		1:25		RECAMBIOS MSP-250-8C			
	MAS DE 30 A 120 mm	±0,15	±0,30	±0,80					Código máquina:			
MAS DE 120 A 400 mm	±0,20	±0,50	±1,20					FAGOR				
MAS DE 400 A 1000 mm	±0,30	±0,80	±2,00					F A G O R I				
MAS DE 1000 A 2000 mm	±0,50	±1,20	±3,00									

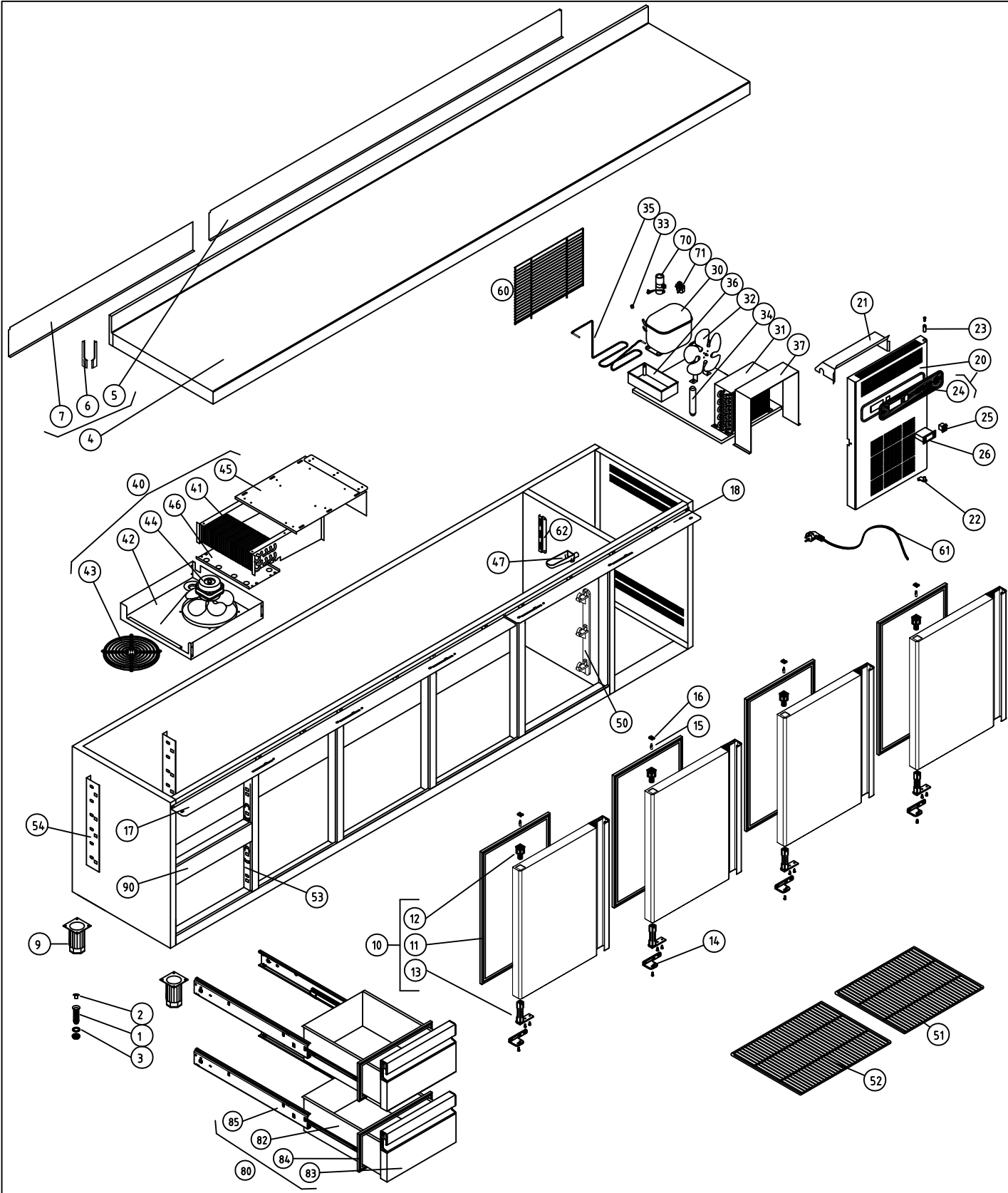

M1 MESAS SNACK						COD. 148111420000										
COTAS SIN TOLERANCIA DIN 7168-f						Material:										
Material:						SUSTITUYE A:										
Acabado:						SUSTITUIDO POR:										
ANGULAR	GRADO TOLERANCIA	FINO	MEDIO	GRUESO	COMUN A	MODELO	Ud.	MODELO	Ud.	MODELO	Ud.	MODELO	Ud.	MODELO	Ud.	
	HASTA 10 mm		±1°	±1° 30'		MSP-300-2C	1									
	MAS DE 10 A 50 mm		±30'	±50'												
	MAS DE 50 A 120 mm		±20'	±25'												
LINEAL	MAS DE 120 A 400 mm		±10'	±15'												
	MAS DE 400 mm		±5'	±10'												
	GRADO TOLERANCIA	FINO	MEDIO	GRUESO	A4	Nombre	Fecha				 F A G O F R I					
	HASTA 3 mm	±0,05	±0,10	±0,15	Dibujado	A.J.GONZALEZ	Feb-2011									
MAS DE 3 A 6 mm	±0,05	±0,10	±0,20	Modificado												
MAS DE 6 A 30 mm	±0,10	±0,20	±0,50	Escala	1:27						Código máquina:					
MAS DE 30 A 120 mm	±0,15	±0,30	±0,80	RECAMBIOS MSP-300-2C												
MAS DE 120 A 400 mm	±0,20	±0,50	±1,20													
MAS DE 400 A 1000 mm	±0,30	±0,80	±2,00													
MAS DE 1000 A 2000 mm	±0,50	±1,20	±3,00													

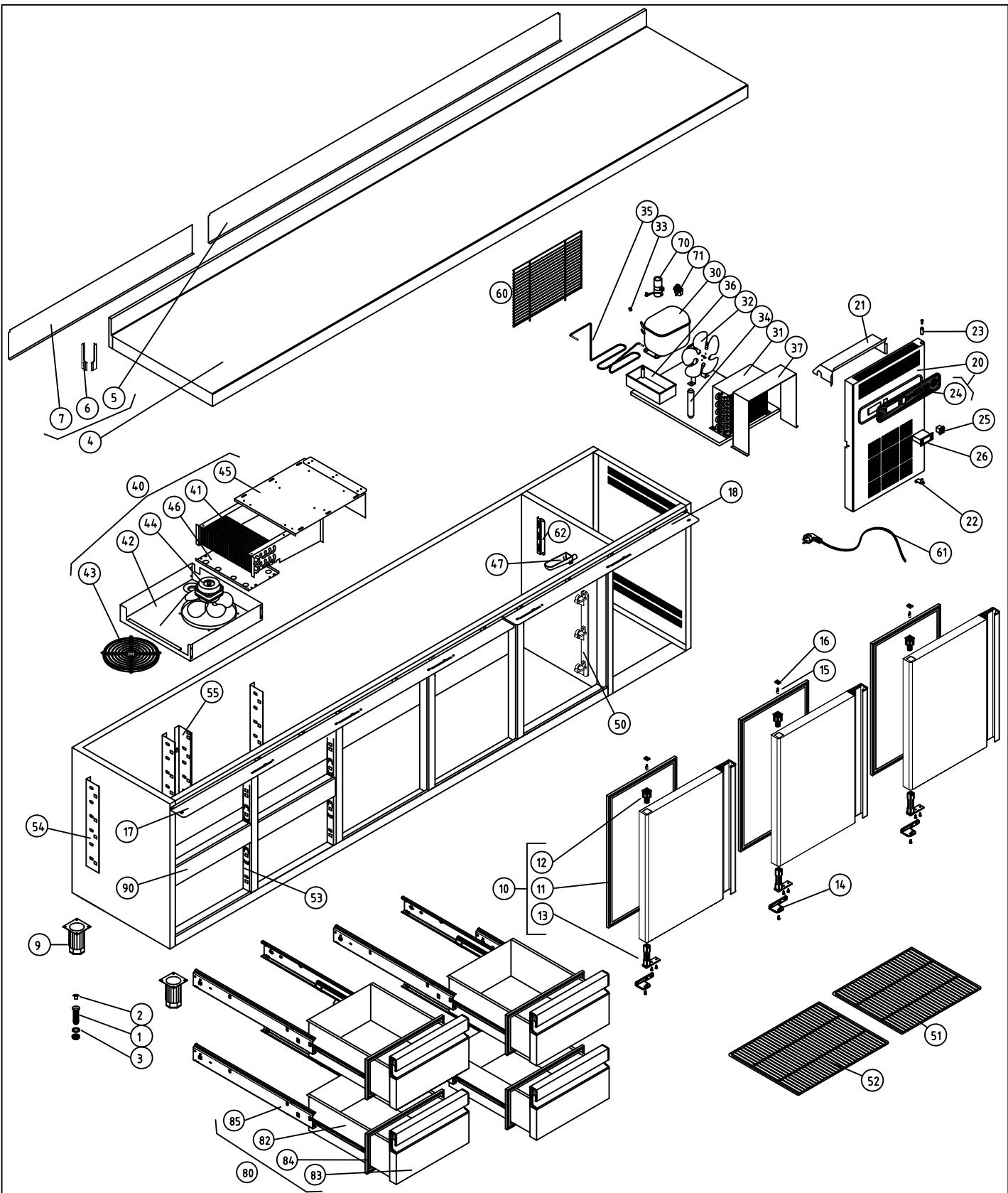

M1 MESAS SNACK						COD. 148111440000							
COTAS SIN TOLERANCIA DIN 7168-f						Material:							
Material:						SUSTITUYE A:							
Acabado:						SUSTITUIDO POR:							
ANGULAR	GRADO TOLERANCIA	FINO	MEDIO	GRUESO	COMUN A	MODELO	Ud.	MODELO	Ud.	MODELO	Ud.	MODELO	Ud.
	HASTA 10 mm		±1°	±1° 30'		MSP-300-4C	1						
	MAS DE 10 A 50 mm		±30'	±50'									
	MAS DE 50 A 120 mm		±20'	±25'									
LINEAL	MAS DE 120 A 400 mm		±10'	±15'									
	MAS DE 400 mm		±5'	±10'									
	GRADO TOLERANCIA	FINO	MEDIO	GRUESO	A4	Nombre	Fecha		 F A G O F R I				
	HASTA 3 mm	±0,05	±0,10	±0,15	Dibujado	A.J.GONZALEZ	Feb-2011						
MAS DE 3 A 6 mm	±0,05	±0,10	±0,20	Modificado									
MAS DE 6 A 30 mm	±0,10	±0,20	±0,50	Escala	1:27			RECAMBIOS MSP-300-4C					
MAS DE 30 A 120 mm	±0,15	±0,30	±0,80				Código máquina:						
MAS DE 120 A 400 mm	±0,20	±0,50	±1,20										
MAS DE 400 A 1000 mm	±0,30	±0,80	±2,00										
MAS DE 1000 A 2000 mm	±0,50	±1,20	±3,00										

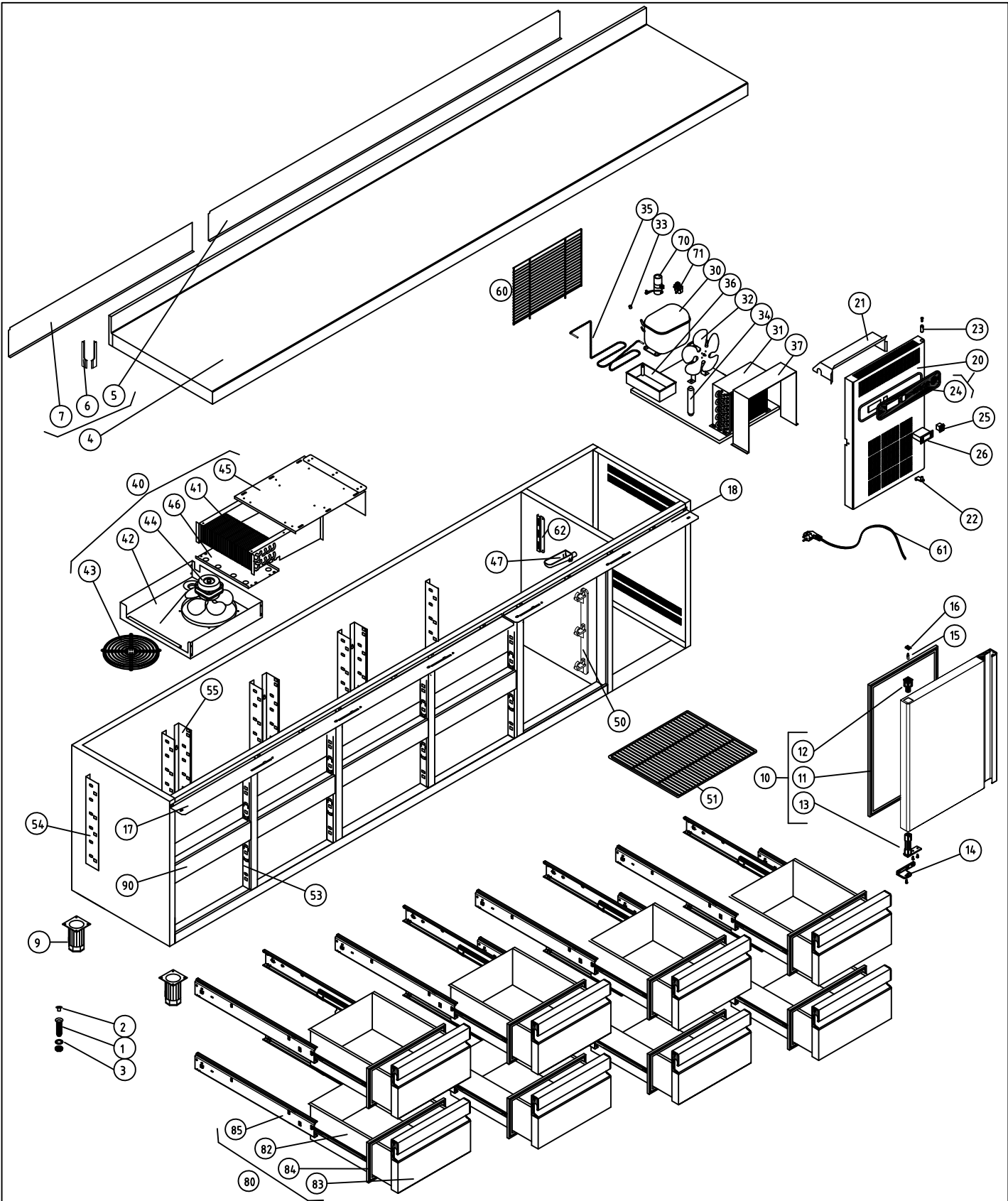

M1 MESAS SNACK						COD. 148111480000								
COTAS SIN TOLERANCIA DIN 7168-f						Material:								
Material:						SUSTITUYE A:								
Acabado:						SUSTITUIDO POR:								
ANGULAR	GRADO TOLERANCIA	FINO	MEDIO	GRUESO	COMUN A	MODELO	Ud.	MODELO	Ud.	MODELO	Ud.	MODELO	Ud.	MODELO
	HASTA 10 mm		±1°	±1° 30'		MSP-300-8C	1							
	MAS DE 10 A 50 mm		±30'	±50'										
	MAS DE 50 A 120 mm		±20'	±25'										
LINEAL	MAS DE 120 A 400 mm		±10'	±15'										
	MAS DE 400 mm		±5'	±10'										
	GRADO TOLERANCIA	FINO	MEDIO	GRUESO	A4	Nombre		Fecha		 F A G O F R I				
	HASTA 3 mm	±0,05	±0,10	±0,15	Dibujado	A.J.GONZALEZ		Feb-2011						
	MAS DE 3 A 6 mm	±0,05	±0,10	±0,20	Modificado									
MAS DE 6 A 30 mm	±0,10	±0,20	±0,50	Escala										
MAS DE 30 A 120 mm	±0,15	±0,30	±0,80	1:27	RECAMBIOS MSP-300-8C				Código máquina:					
MAS DE 120 A 400 mm	±0,20	±0,50	±1,20											
MAS DE 400 A 1000 mm	±0,30	±0,80	±2,00											
MAS DE 1000 A 2000 mm	±0,50	±1,20	±3,00											

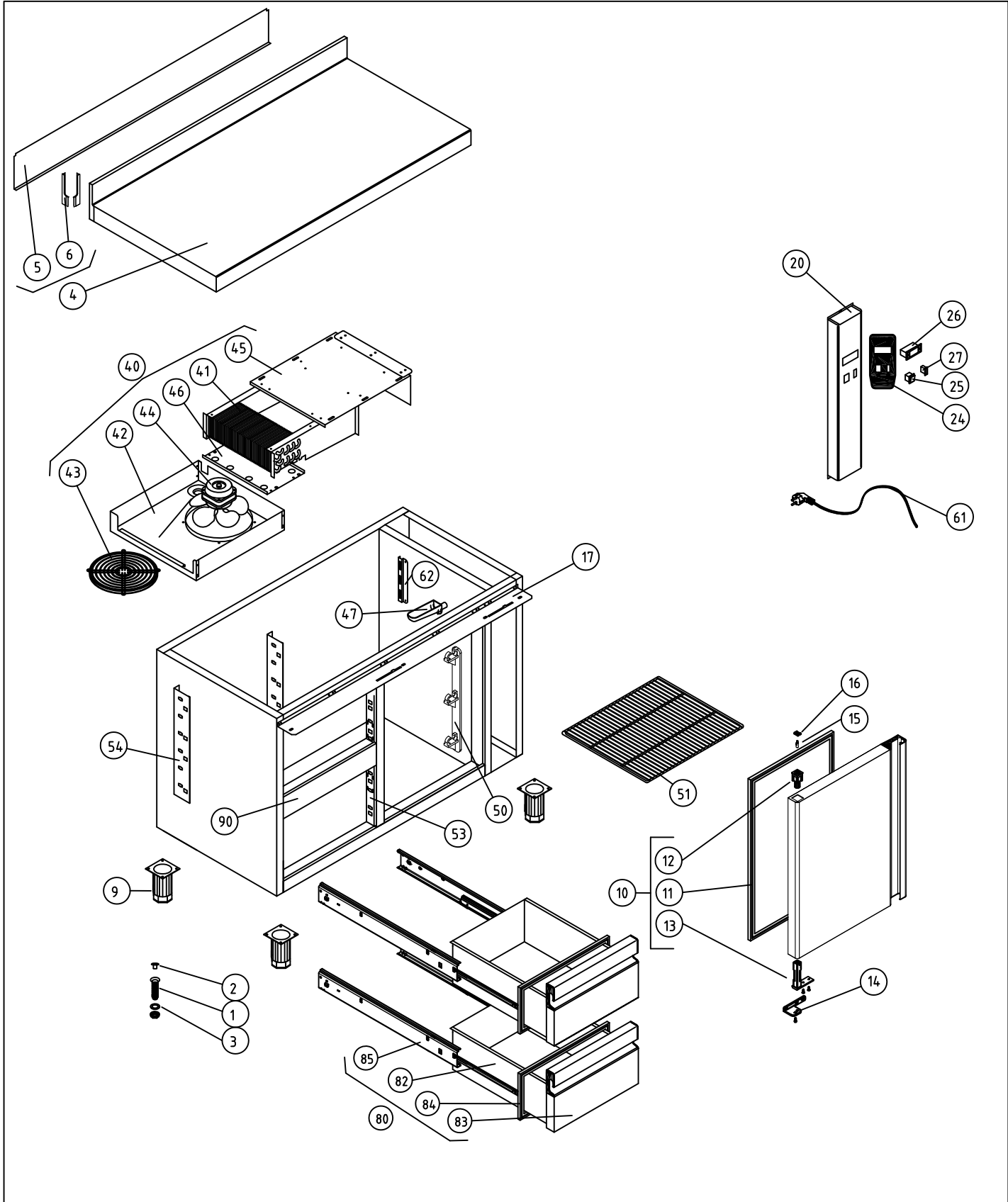

M1 MESAS FRÍAS				COD. PIEZA: 148111121000				
COTAS SIN TOLERANCIA DIN 7168-f				Material: MATERIAL ESPESOR				
				Acabado: ACABADO				
ANGULAR	GRADO TOLERANCIA	FINO	MEDIO	GRUESO				
	HASTA 10 mm		±1°	±1° 30'				
	MAS DE 10 A 50 mm		±30'	±50'				
	MAS DE 50 A 120 mm		±20'	±25'				
LINEAL	MAS DE 120 A 400 mm		±10'	±15'				
	MAS DE 400 mm		±5'	±10'				
	MAS DE 3 mm		±0,05	±0,10	±0,15			
	MAS DE 6 A 30 mm		±0,10	±0,20	±0,50			
COMUN A	MAS DE 30 A 120 mm		±0,15	±0,30	±0,80			
	MAS DE 120 A 400 mm		±0,20	±0,50	±1,20			
	MAS DE 400 A 1000 mm		±0,30	±0,80	±2,00			
	MAS DE 1000 A 2000 mm		±0,50	±1,20	±3,00			
A4		Nombre		Fecha		 F A G O F R I		
Dibujado		A.J.GONZALEZ		Feb-2011				
Modificado								
Escala		1:22		RECAMBIOS MSP-117-2RC				
				Código máquina: CODIGO				

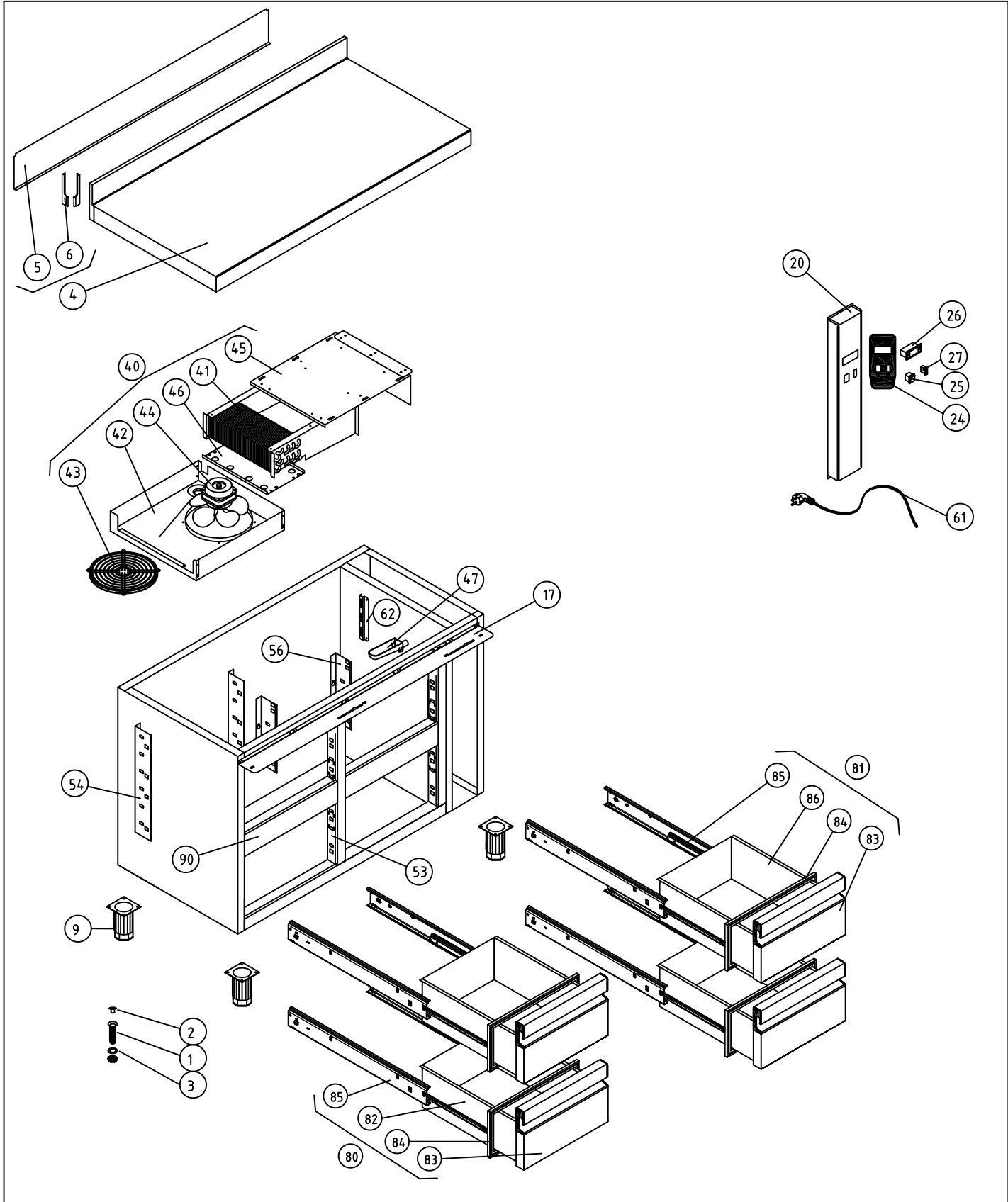

M1 MESAS FRÍAS				COD. PIEZA: 148111141000						
COTAS SIN TOLERANCIA DIN 7168-f				Material: MATERIAL ESPESOR						
				Acabado: ACABADO						
ANGULAR	GRADO TOLERANCIA	FINO	MEDIO	GRUESO						
	HASTA 10 mm		±1°	±1° 30'						
	MAS DE 10 A 50 mm		±30'	±50'						
	MAS DE 50 A 120 mm		±20'	±25'						
	MAS DE 120 A 400 mm		±10'	±15'						
MAS DE 400 mm		±5'	±10'							
LINEAL	GRADO TOLERANCIA	FINO	MEDIO	GRUESO						
	HASTA 3 mm		±0,05	±0,10	±0,15					
	MAS DE 3 A 6 mm		±0,05	±0,10	±0,20					
	MAS DE 6 A 30 mm		±0,10	±0,20	±0,50					
	MAS DE 30 A 120 mm		±0,15	±0,30	±0,80					
	MAS DE 120 A 400 mm		±0,20	±0,50	±1,20					
MAS DE 400 A 1000 mm		±0,30	±0,80	±2,00						
MAS DE 1000 A 2000 mm		±0,50	±1,20	±3,00						
COMUN A		MODELO	Ud.	MODELO	Ud.	MODELO	Ud.	MODELO	Ud.	MODELO
		MSP-117-4RC	1							
A4		Nombre		Fecha		 F A G O R F R I				
Dibujado		A.J.GONZALEZ		Feb-2011						
Modificado										
Escala		1:22		RECAMBIOS MSP-117-4RC					Código máquina: CODIGO	

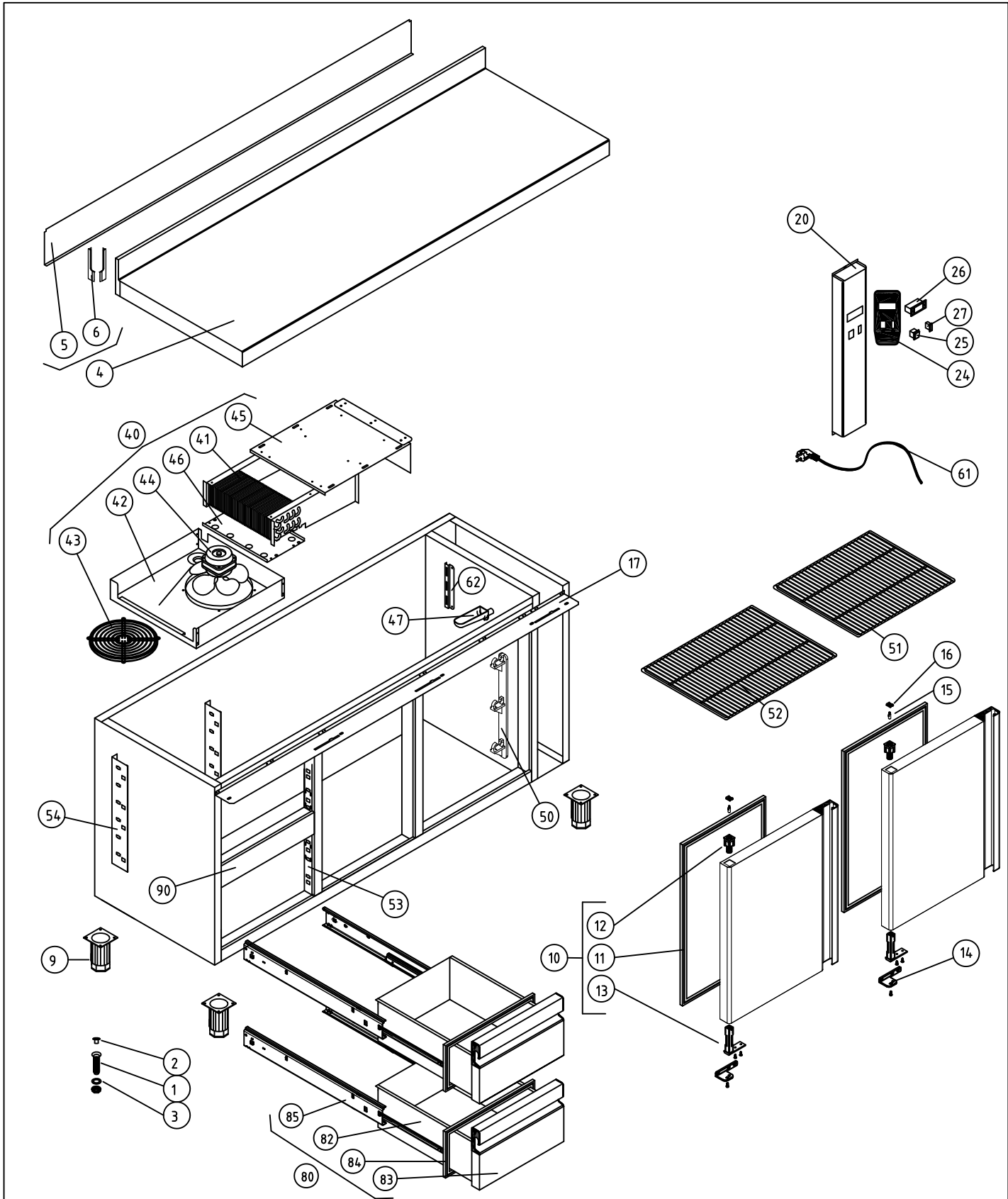

M1 MESAS FRÍAS				COD. PIEZA: 14.8111221000						
COTAS SIN TOLERANCIA DIN 7168-f				Material: MATERIAL ESPESOR						
				Acabado: ACABADO						
ANGULAR	GRADO TOLERANCIA	FINO	MEDIO	GRUESO						
	HASTA 10 mm		±1°	±1° 30'						
	MAS DE 10 A 50 mm		±30'	±50'						
	MAS DE 50 A 120 mm		±20'	±25'						
	MAS DE 120 A 400 mm		±10'	±15'						
MAS DE 400 mm		±5'	±10'							
LINEAL	GRADO TOLERANCIA	FINO	MEDIO	GRUESO						
	HASTA 3 mm		±0,05	±0,10	±0,15					
	MAS DE 3 A 6 mm		±0,05	±0,10	±0,20					
	MAS DE 6 A 30 mm		±0,10	±0,20	±0,50					
	MAS DE 30 A 120 mm		±0,15	±0,30	±0,80					
	MAS DE 120 A 400 mm		±0,20	±0,50	±1,20					
	MAS DE 400 A 1000 mm		±0,30	±0,80	±2,00					
MAS DE 1000 A 2000 mm		±0,50	±1,20	±3,00						
COMUN A		MODELO	Ud.	MODELO	Ud.	MODELO	Ud.	MODELO	Ud.	MODELO
		MSP-169-R2C	1							
A4		Nombre	Fecha			 F A G O F R I				
Dibujado		A.J.GONZALEZ	Feb-2011							
Modificado										
Escala		1:22				RECAMBIOS MSP-169-R2C				Código máquina: CODIGO

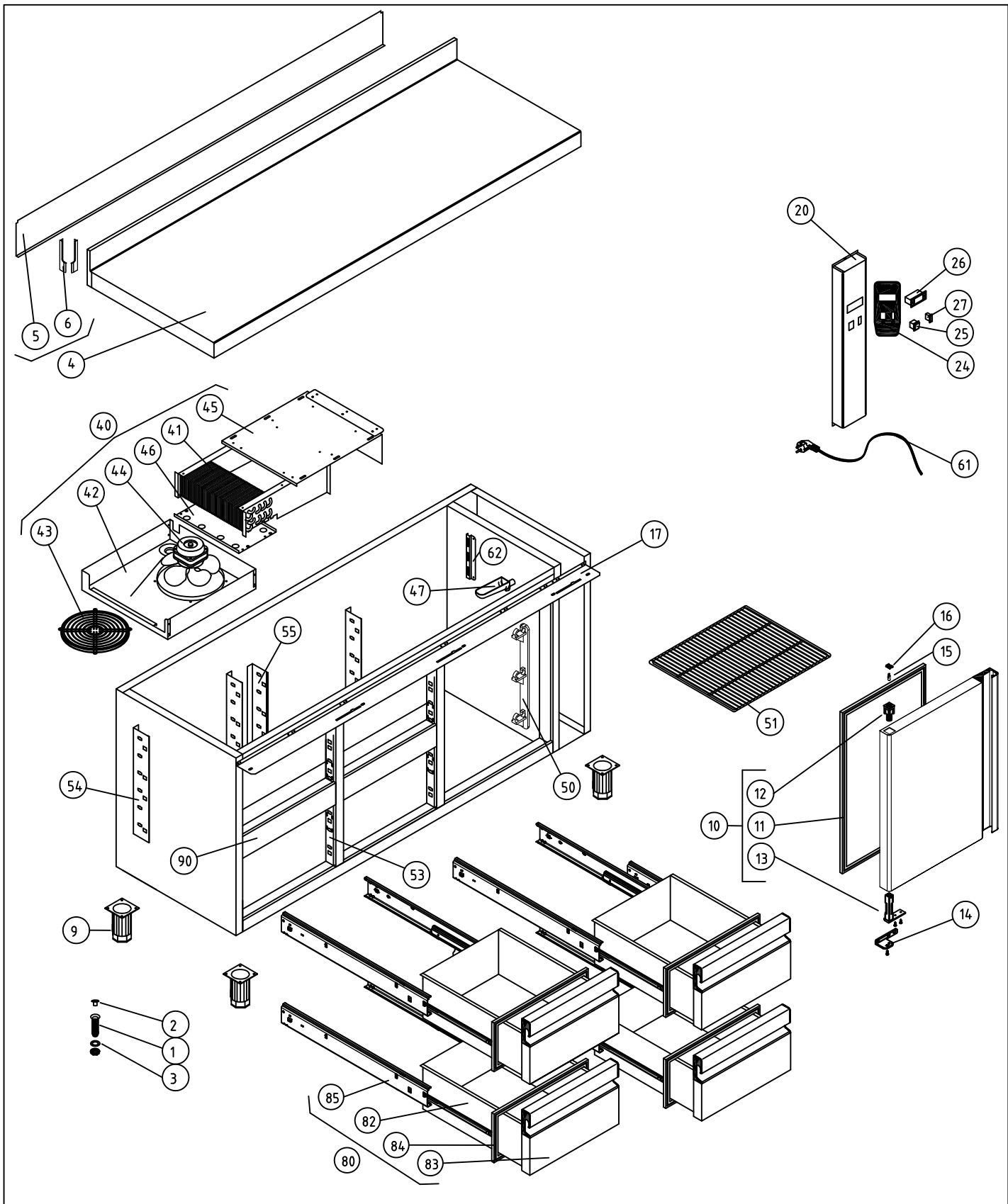

M1 MESAS FRÍAS				COD. PIEZA: 148111241000					
COTAS SIN TOLERANCIA DIN 7168-f				Material: MATERIAL ESPESOR					
				Acabado: ACABADO					
ANGULAR	GRADO TOLERANCIA	FINO	MEDIO	GRUESO					
	HASTA 10 mm		±1°	±1° 30'					
	MAS DE 10 A 50 mm		±30'	±50'					
	MAS DE 50 A 120 mm		±20'	±25'					
LINEAL	GRADO TOLERANCIA	FINO	MEDIO	GRUESO					
	HASTA 3 mm		±0,05	±0,10	±0,15				
	MAS DE 3 A 6 mm		±0,05	±0,10	±0,20				
	MAS DE 6 A 30 mm		±0,10	±0,20	±0,50				
COMUN A	MODELO	Ud.	MODELO	Ud.	MODELO	Ud.	MODELO	Ud.	MODELO
	MSP-169-R4C	1							
A4		Nombre		Fecha		 F A G O F R I			
Dibujado		A.J.GONZALEZ		Feb-2011					
Modificado									
Escala		1:22		RECAMBIOS MSP-169-R4C				Código máquina: CODIGO	

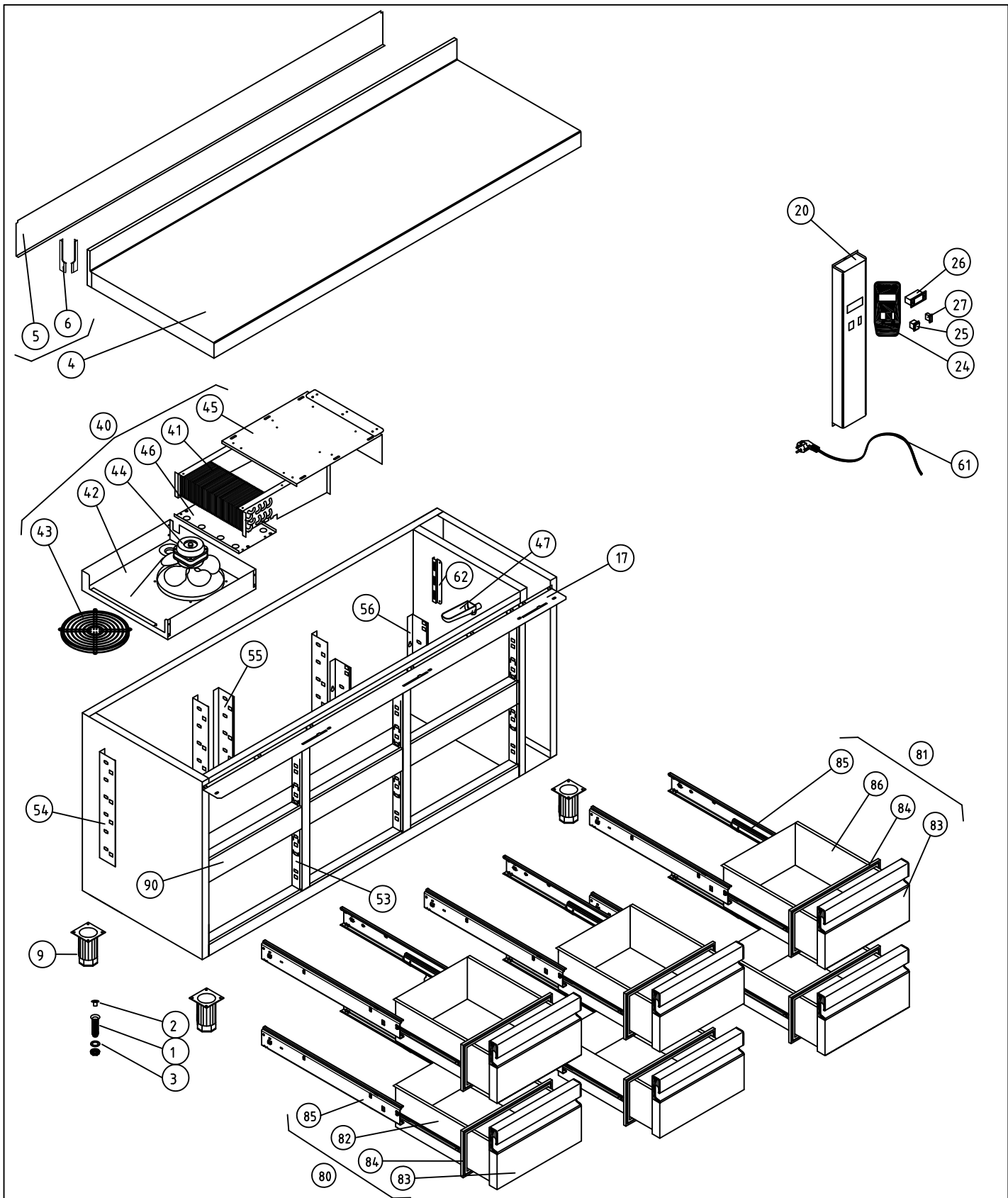

M1 MESAS FRÍAS				COD. PIEZA: 148111261000						
COTAS SIN TOLERANCIA DIN 7168-f				Material: MATERIAL ESPESOR						
				Acabado: ACABADO						
ANGULAR	GRADO TOLERANCIA	FINO	MEDIO	GRUESO						
	HASTA 10 mm		±1°	±1° 30'						
	MAS DE 10 A 50 mm		±30'	±50'						
	MAS DE 50 A 120 mm		±20'	±25'						
	MAS DE 120 A 400 mm		±10'	±15'						
MAS DE 400 mm		±5'	±10'							
LINEAL	GRADO TOLERANCIA	FINO	MEDIO	GRUESO						
	HASTA 3 mm		±0,05	±0,10	±0,15					
	MAS DE 3 A 6 mm		±0,05	±0,10	±0,20					
	MAS DE 6 A 30 mm		±0,10	±0,20	±0,50					
	MAS DE 30 A 120 mm		±0,15	±0,30	±0,80					
	MAS DE 120 A 400 mm		±0,20	±0,50	±1,20					
	MAS DE 400 A 1000 mm		±0,30	±0,80	±2,00					
MAS DE 1000 A 2000 mm		±0,50	±1,20	±3,00						
COMUN A		MODELO	Ud.	MODELO	Ud.	MODELO	Ud.	MODELO	Ud.	MODELO
		MSP-169-R6C	1							
A4		Nombre			Fecha			 F A G O F R I		
Dibujado		A.J.GONZALEZ			Feb-2011					
Modificado										
Escala		1:22			RECAMBIOS MSP-169-R6C			Código máquina: CODIGO		

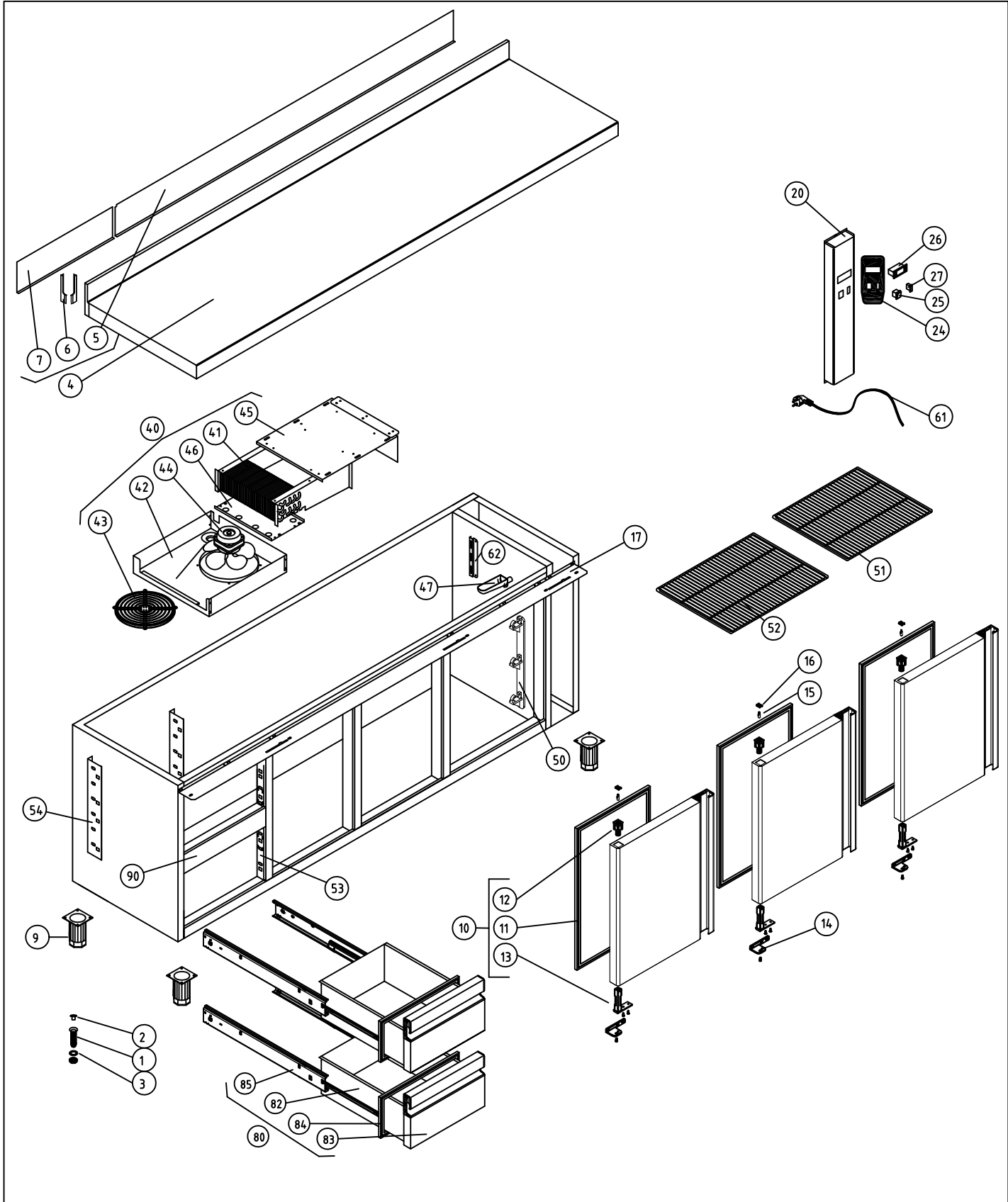

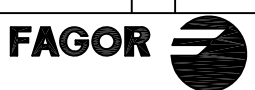
M1 MESAS SNACK					COD. PIEZA: 148111321000									
COTAS SIN TOLERANCIA DIN 7168-f					Material:									
					SUSTITUYE A:									
					SUSTITUIDO POR:									
ANGULAR	GRADO TOLERANCIA	FINO	MEDIO	GRUESO	COMUN A	MODELO	Ud.	MODELO	Ud.	MODELO	Ud.	MODELO	Ud.	MODELO
	HASTA 10 mm		±1°	±1° 30'		MSP-222-R2C	1							
	MAS DE 10 A 50 mm		±30'	±50'										
	MAS DE 50 A 120 mm		±20'	±25'										
LINEAL	MAS DE 120 A 400 mm		±10'	±15'										
	MAS DE 400 mm		±5'	±10'										
	GRADO TOLERANCIA	FINO	MEDIO	GRUESO	A4	Nombre	Fecha							
	HASTA 3 mm	±0,05	±0,10	±0,15	Dibujado	A.J.GONZALEZ	Feb-2011							
	MAS DE 3 A 6 mm	±0,05	±0,10	±0,20	Modificado									
MAS DE 6 A 30 mm	±0,10	±0,20	±0,50	Escala	RECAMBIOS MSP-222-R2C									
MAS DE 30 A 120 mm	±0,15	±0,30	±0,80	1:25										
MAS DE 120 A 400 mm	±0,20	±0,50	±1,20											
MAS DE 400 A 1000 mm	±0,30	±0,80	±2,00		Código máquina:									
MAS DE 1000 A 2000 mm	±0,50	±1,20	±3,00											

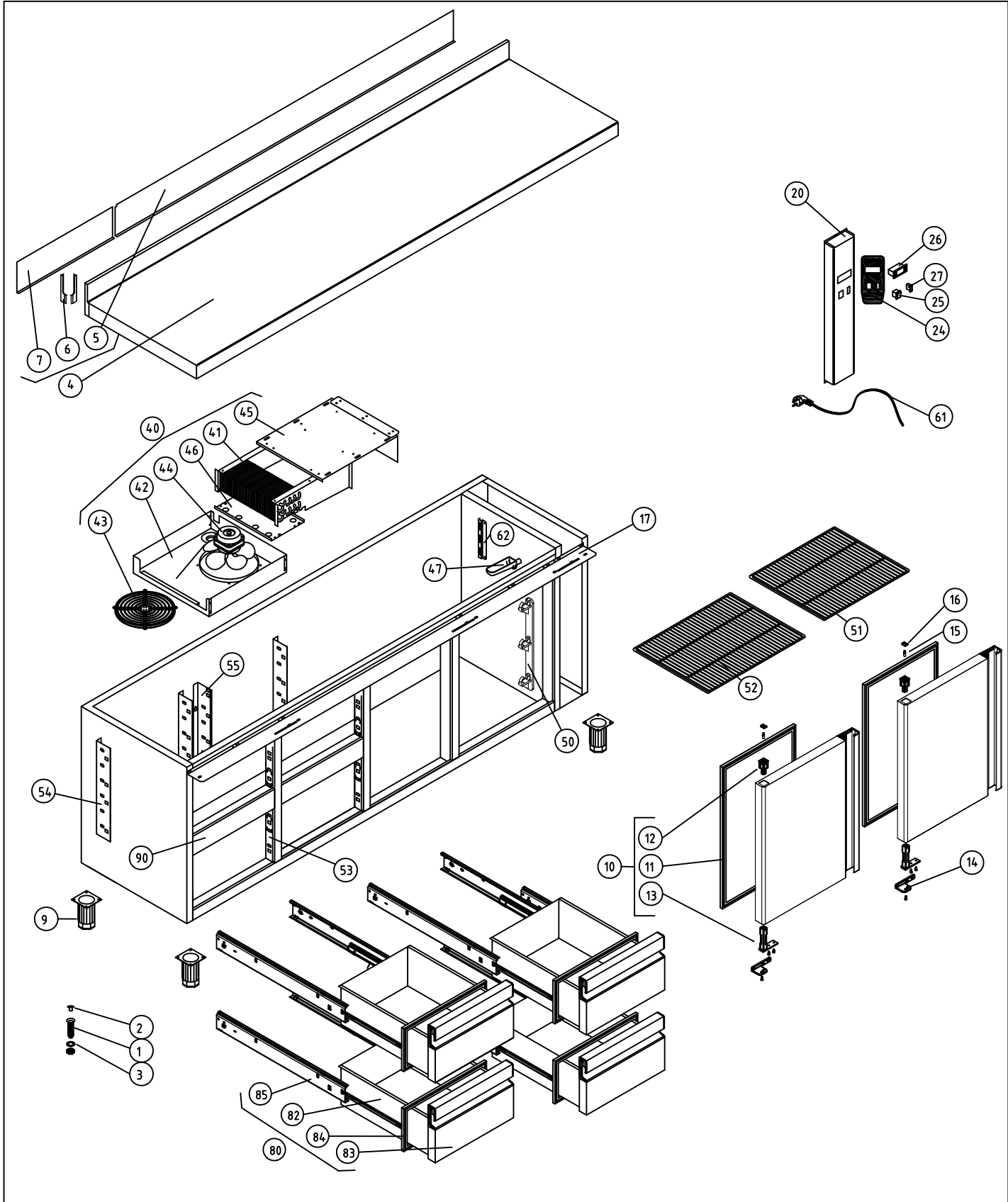

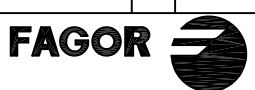
M1 MESAS SNACK					COD. PIEZA: 148111341000									
COTAS SIN TOLERANCIA DIN 7168-f					Material:									
					SUSTITUYE A:									
					SUSTITUIDO POR:									
ANGULAR	GRADO TOLERANCIA	FINO	MEDIO	GRUESO	COMUN A	MODELO	Ud.	MODELO	Ud.	MODELO	Ud.	MODELO	Ud.	
	HASTA 10 mm		±1°	±1° 30'		MSP-222-R4C	1							
	MAS DE 10 A 50 mm		±30'	±50'										
	MAS DE 50 A 120 mm		±20'	±25'										
	MAS DE 120 A 400 mm		±10'	±15'										
MAS DE 400 mm		±5'	±10'											
LINEAL	GRADO TOLERANCIA	FINO	MEDIO	GRUESO	A4	Nombre		Fecha						
	HASTA 3 mm	±0,05	±0,10	±0,15	Dibujado	A.J.GONZALEZ		Feb-2011						
	MAS DE 3 A 6 mm	±0,05	±0,10	±0,20	Modificado									
	MAS DE 6 A 30 mm	±0,10	±0,20	±0,50	Escala	1:25				RECAMBIOS MSP-222-R4C				
	MAS DE 30 A 120 mm	±0,15	±0,30	±0,80						Código máquina:				
MAS DE 120 A 400 mm	±0,20	±0,50	±1,20											
MAS DE 400 A 1000 mm	±0,30	±0,80	±2,00											
MAS DE 1000 A 2000 mm	±0,50	±1,20	±3,00											

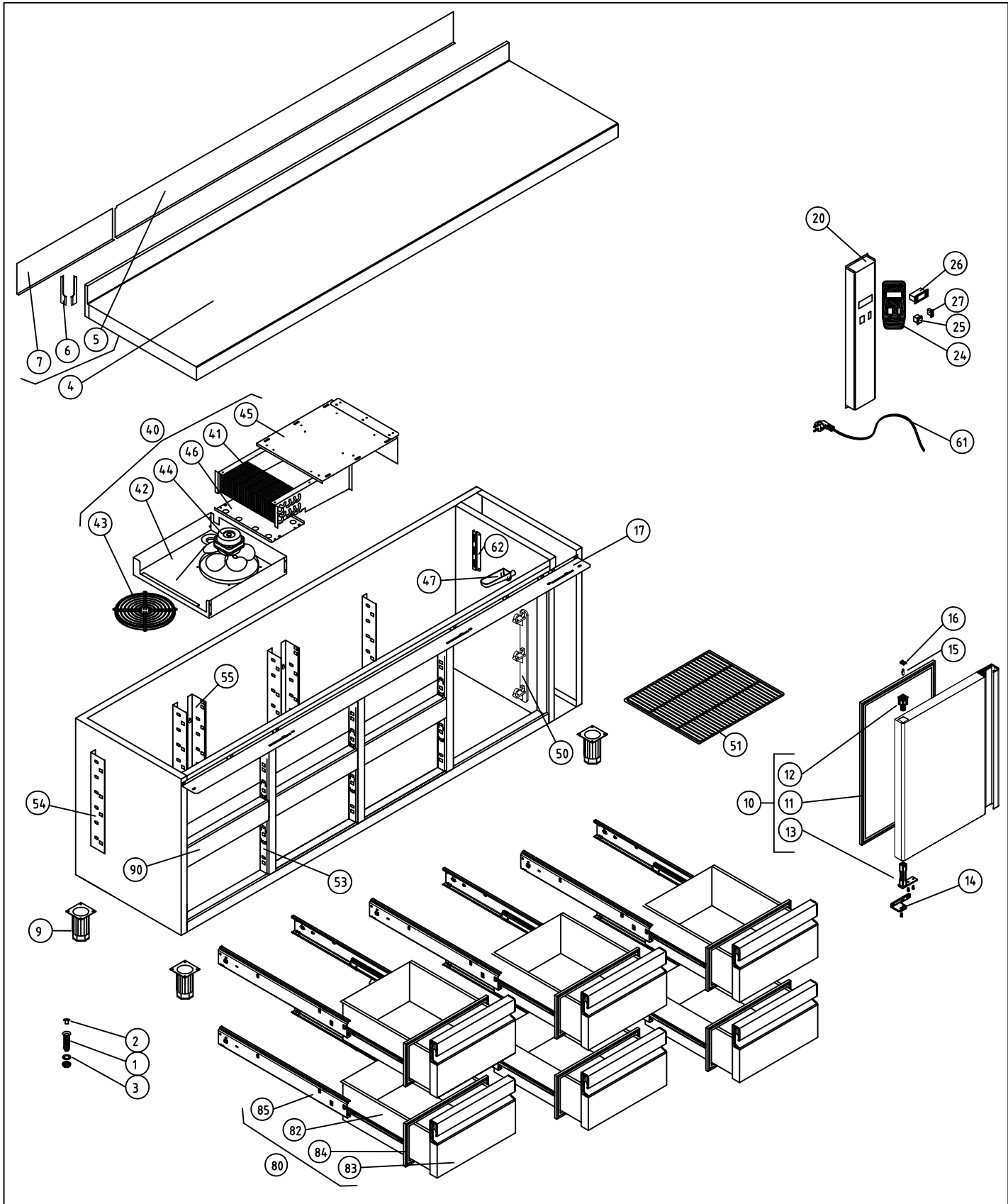

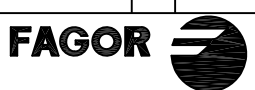
M1 MESAS SNACK						COD. PIEZA: 148111361000																																													
COTAS SIN TOLERANCIA DIN 7168-f						Material:																																													
<table border="1"> <thead> <tr> <th>GRADO TOLERANCIA</th> <th>FINO</th> <th>MEDIO</th> <th>GRUESO</th> </tr> </thead> <tbody> <tr> <td>HASTA 10 mm</td> <td></td> <td>±1°</td> <td>±1° 30'</td> </tr> <tr> <td>MAS DE 10 A 50 mm</td> <td></td> <td>±30'</td> <td>±50'</td> </tr> <tr> <td>MAS DE 50 A 120 mm</td> <td></td> <td>±20'</td> <td>±25'</td> </tr> <tr> <td>MAS DE 120 A 400 mm</td> <td></td> <td>±10'</td> <td>±15'</td> </tr> <tr> <td>MAS DE 400 mm</td> <td></td> <td>±5'</td> <td>±10'</td> </tr> </tbody> </table>						GRADO TOLERANCIA	FINO	MEDIO	GRUESO	HASTA 10 mm		±1°	±1° 30'	MAS DE 10 A 50 mm		±30'	±50'	MAS DE 50 A 120 mm		±20'	±25'	MAS DE 120 A 400 mm		±10'	±15'	MAS DE 400 mm		±5'	±10'	Acabado:																					
GRADO TOLERANCIA	FINO	MEDIO	GRUESO																																																
HASTA 10 mm		±1°	±1° 30'																																																
MAS DE 10 A 50 mm		±30'	±50'																																																
MAS DE 50 A 120 mm		±20'	±25'																																																
MAS DE 120 A 400 mm		±10'	±15'																																																
MAS DE 400 mm		±5'	±10'																																																
<table border="1"> <thead> <tr> <th>ANGULAR</th> <th>GRADO TOLERANCIA</th> <th>FINO</th> <th>MEDIO</th> <th>GRUESO</th> </tr> </thead> <tbody> <tr> <td></td> <td>HASTA 3 mm</td> <td>±0,05</td> <td>±0,10</td> <td>±0,15</td> </tr> <tr> <td></td> <td>MAS DE 3 A 6 mm</td> <td>±0,05</td> <td>±0,10</td> <td>±0,20</td> </tr> <tr> <td></td> <td>MAS DE 6 A 30 mm</td> <td>±0,10</td> <td>±0,20</td> <td>±0,50</td> </tr> <tr> <td></td> <td>MAS DE 30 A 120 mm</td> <td>±0,15</td> <td>±0,30</td> <td>±0,80</td> </tr> <tr> <td></td> <td>MAS DE 120 A 400 mm</td> <td>±0,20</td> <td>±0,50</td> <td>±1,20</td> </tr> <tr> <td></td> <td>MAS DE 400 A 1000 mm</td> <td>±0,30</td> <td>±0,80</td> <td>±2,00</td> </tr> <tr> <td></td> <td>MAS DE 1000 A 2000 mm</td> <td>±0,50</td> <td>±1,20</td> <td>±3,00</td> </tr> </tbody> </table>						ANGULAR	GRADO TOLERANCIA	FINO	MEDIO	GRUESO		HASTA 3 mm	±0,05	±0,10	±0,15		MAS DE 3 A 6 mm	±0,05	±0,10	±0,20		MAS DE 6 A 30 mm	±0,10	±0,20	±0,50		MAS DE 30 A 120 mm	±0,15	±0,30	±0,80		MAS DE 120 A 400 mm	±0,20	±0,50	±1,20		MAS DE 400 A 1000 mm	±0,30	±0,80	±2,00		MAS DE 1000 A 2000 mm	±0,50	±1,20	±3,00	SUSTITUYE A:					
ANGULAR	GRADO TOLERANCIA	FINO	MEDIO	GRUESO																																															
	HASTA 3 mm	±0,05	±0,10	±0,15																																															
	MAS DE 3 A 6 mm	±0,05	±0,10	±0,20																																															
	MAS DE 6 A 30 mm	±0,10	±0,20	±0,50																																															
	MAS DE 30 A 120 mm	±0,15	±0,30	±0,80																																															
	MAS DE 120 A 400 mm	±0,20	±0,50	±1,20																																															
	MAS DE 400 A 1000 mm	±0,30	±0,80	±2,00																																															
	MAS DE 1000 A 2000 mm	±0,50	±1,20	±3,00																																															
<table border="1"> <thead> <tr> <th>COMUN A</th> <th>MODELO</th> <th>Ud.</th> <th>MODELO</th> <th>Ud.</th> <th>MODELO</th> <th>Ud.</th> <th>MODELO</th> <th>Ud.</th> <th>MODELO</th> <th>Ud.</th> </tr> </thead> <tbody> <tr> <td></td> <td>MSP-222-R6C</td> <td></td> <td></td> <td></td> <td></td> <td></td> <td></td> <td></td> <td></td> <td></td> </tr> </tbody> </table>						COMUN A	MODELO	Ud.	MODELO	Ud.	MODELO	Ud.	MODELO	Ud.	MODELO	Ud.		MSP-222-R6C										SUSTITUIDO POR:																							
COMUN A	MODELO	Ud.	MODELO	Ud.	MODELO	Ud.	MODELO	Ud.	MODELO	Ud.																																									
	MSP-222-R6C																																																		
<table border="1"> <thead> <tr> <th>LINEAL</th> <th>GRADO TOLERANCIA</th> <th>FINO</th> <th>MEDIO</th> <th>GRUESO</th> </tr> </thead> <tbody> <tr> <td></td> <td>HASTA 3 mm</td> <td>±0,05</td> <td>±0,10</td> <td>±0,15</td> </tr> <tr> <td></td> <td>MAS DE 3 A 6 mm</td> <td>±0,05</td> <td>±0,10</td> <td>±0,20</td> </tr> <tr> <td></td> <td>MAS DE 6 A 30 mm</td> <td>±0,10</td> <td>±0,20</td> <td>±0,50</td> </tr> <tr> <td></td> <td>MAS DE 30 A 120 mm</td> <td>±0,15</td> <td>±0,30</td> <td>±0,80</td> </tr> <tr> <td></td> <td>MAS DE 120 A 400 mm</td> <td>±0,20</td> <td>±0,50</td> <td>±1,20</td> </tr> <tr> <td></td> <td>MAS DE 400 A 1000 mm</td> <td>±0,30</td> <td>±0,80</td> <td>±2,00</td> </tr> <tr> <td></td> <td>MAS DE 1000 A 2000 mm</td> <td>±0,50</td> <td>±1,20</td> <td>±3,00</td> </tr> </tbody> </table>						LINEAL	GRADO TOLERANCIA	FINO	MEDIO	GRUESO		HASTA 3 mm	±0,05	±0,10	±0,15		MAS DE 3 A 6 mm	±0,05	±0,10	±0,20		MAS DE 6 A 30 mm	±0,10	±0,20	±0,50		MAS DE 30 A 120 mm	±0,15	±0,30	±0,80		MAS DE 120 A 400 mm	±0,20	±0,50	±1,20		MAS DE 400 A 1000 mm	±0,30	±0,80	±2,00		MAS DE 1000 A 2000 mm	±0,50	±1,20	±3,00	A4		Nombre		Fecha	
LINEAL	GRADO TOLERANCIA	FINO	MEDIO	GRUESO																																															
	HASTA 3 mm	±0,05	±0,10	±0,15																																															
	MAS DE 3 A 6 mm	±0,05	±0,10	±0,20																																															
	MAS DE 6 A 30 mm	±0,10	±0,20	±0,50																																															
	MAS DE 30 A 120 mm	±0,15	±0,30	±0,80																																															
	MAS DE 120 A 400 mm	±0,20	±0,50	±1,20																																															
	MAS DE 400 A 1000 mm	±0,30	±0,80	±2,00																																															
	MAS DE 1000 A 2000 mm	±0,50	±1,20	±3,00																																															
Dibujado		A.J.GONZALEZ		Feb-2011																																															
Modificado																																																			
Escala		1:25																																																	
																																																			
RECAMBIOS MSP-222-R6C																																																			
Código máquina:																																																			

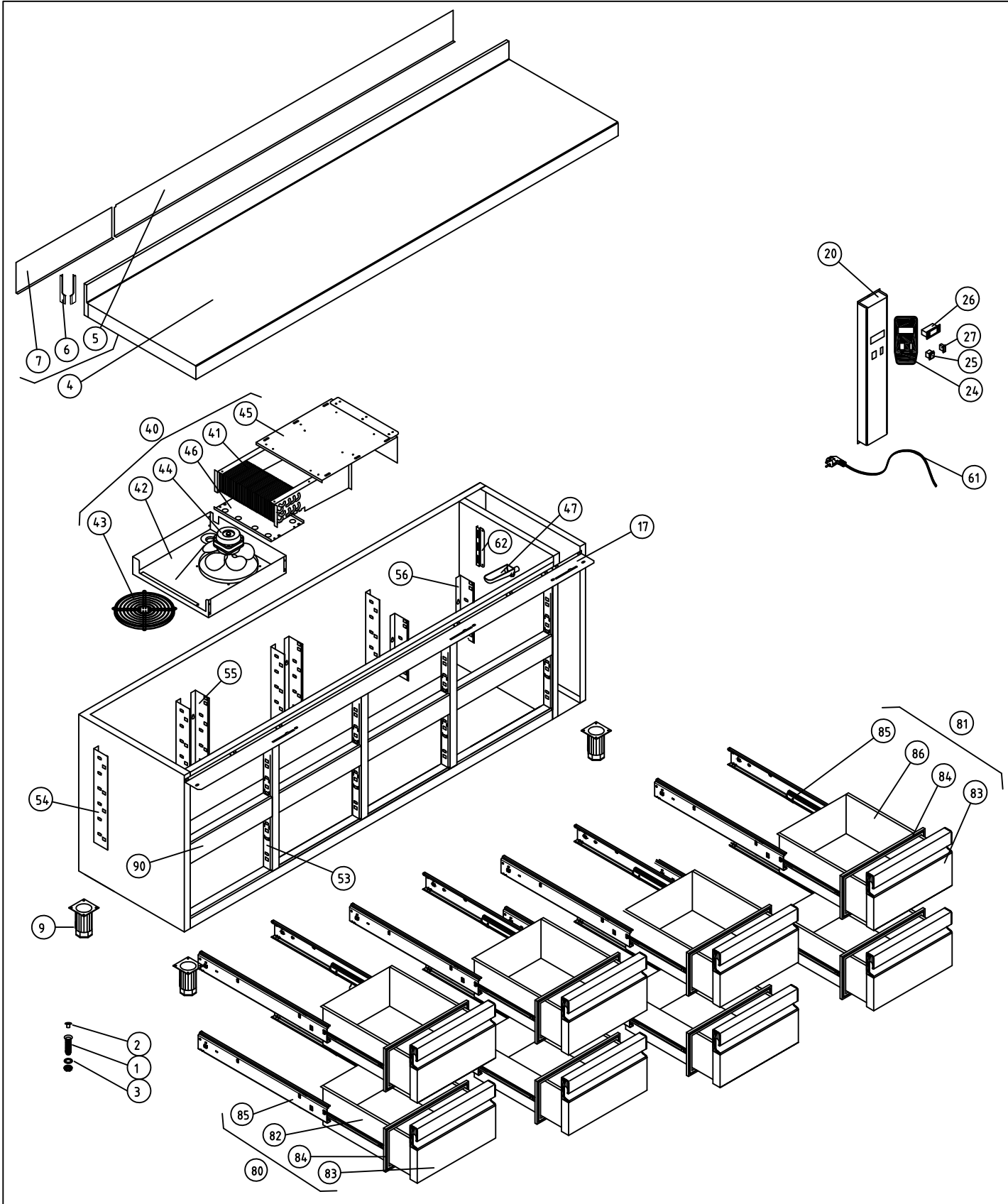

M1 MESAS SNACK						COD. PIEZA: 148111381000								
COTAS SIN TOLERANCIA DIN 7168-f						Material:				SUSTITUYE A:				
ANGULAR	GRADO TOLERANCIA	FINO	MEDIO	GRUESO	Acabado:				SUSTITUIDO POR:					
	HASTA 10 mm		±1°	±1° 30'	COMUN A		MODELO	Ud.	MODELO	Ud.	MODELO	Ud.	MODELO	Ud.
	MÁS DE 10 A 50 mm		±30'	±50'	MSP-222-R8C									
	MÁS DE 50 A 120 mm		±20'	±25'										
LINEAL	MÁS DE 120 A 400 mm		±10'	±15'	Escala		Nombre		Fecha		 F A G O F R I			
	MÁS DE 400 mm		±5'	±10'	1:25		A4		Feb-2011					
	GRADO TOLERANCIA	FINO	MEDIO	GRUESO	Dibujado		A.J.GONZALEZ		Modificado		Código máquina:			
	HASTA 3 mm	±0,05	±0,10	±0,15	RECAMBIOS MSP-222-R8C									
	MÁS DE 3 A 6 mm	±0,05	±0,10	±0,20										
MÁS DE 6 A 30 mm	±0,10	±0,20	±0,50											
MÁS DE 30 A 120 mm	±0,15	±0,30	±0,80											
MÁS DE 120 A 400 mm	±0,20	±0,50	±1,20											
MÁS DE 400 A 1000 mm	±0,30	±0,80	±2,00											
MÁS DE 1000 A 2000 mm	±0,50	±1,20	±3,00											

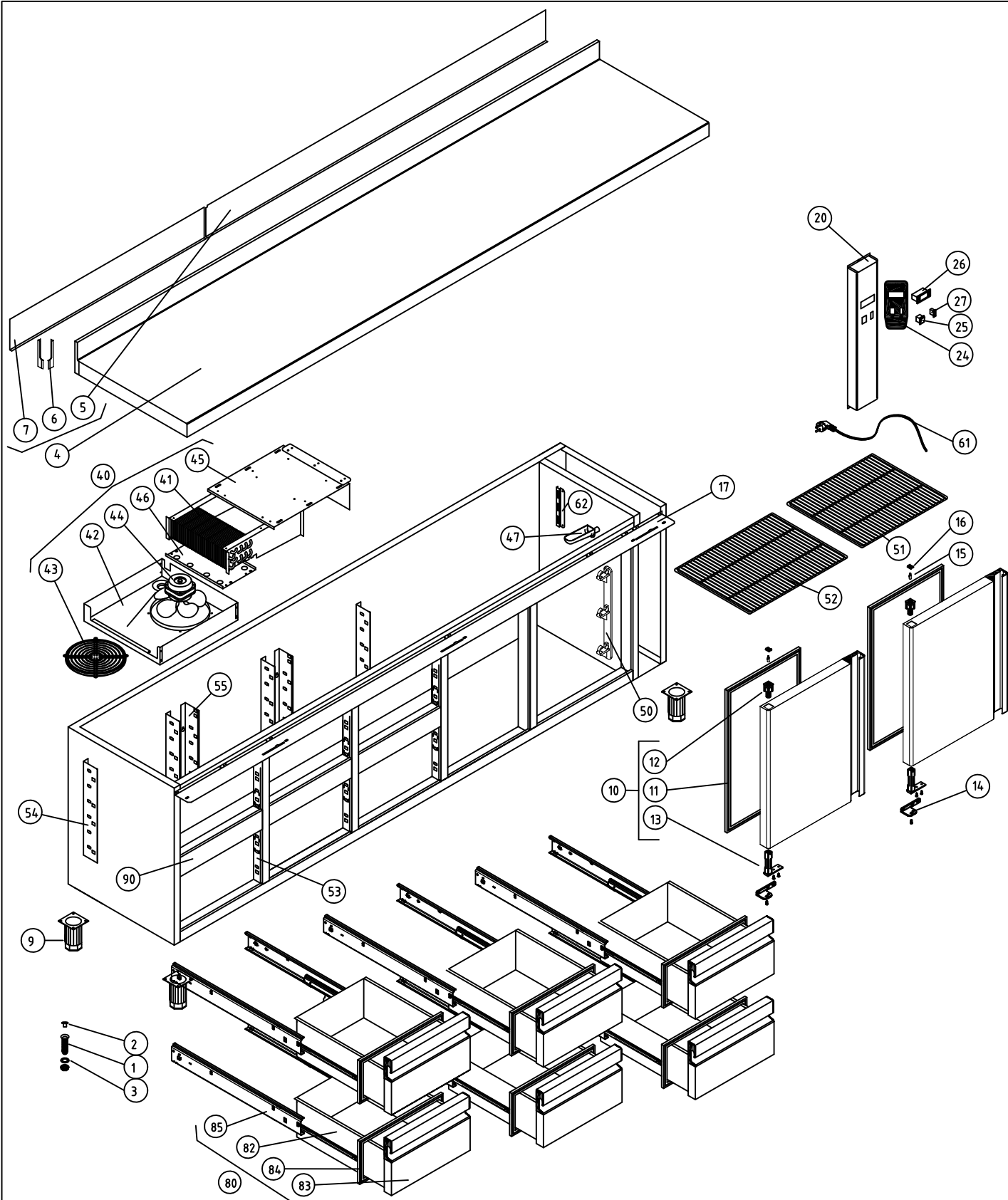

M1 MESAS SNACK COD. PIEZA: 148111461000

COTAS SIN TOLERANCIA DIN 7168-f Material: SUSTITUYE A:

ANGULAR	GRADO TOLERANCIA	FINO	MEDIO	GRUESO	COMUN A	MODELO	Ud.	MODELO	Ud.	MODELO	Ud.	MODELO	Ud.	MODELO	Ud.
	HASTA 10 mm		±1°			±1° 30'	MSP-274-R6C								
MAS DE 10 A 50 mm		±30'		±50'											
MAS DE 50 A 120 mm		±20'		±25'											
MAS DE 120 A 400 mm		±10'		±15'											
MAS DE 400 mm		±5'		±10'											

LINEAL	GRADO TOLERANCIA	FINO	MEDIO	GRUESO	A4	Nombre	Fecha	FAGOR F A G O F R I
	HASTA 3 mm		±0,05	±0,10	±0,15	Dibujado	A.J.GONZALEZ	
MAS DE 3 A 6 mm		±0,05	±0,10	±0,20	Modificado			
MAS DE 6 A 30 mm		±0,10	±0,20	±0,50	Escala			
MAS DE 30 A 120 mm		±0,15	±0,30	±0,80				
MAS DE 120 A 400 mm		±0,20	±0,50	±1,20				
MAS DE 400 A 1000 mm		±0,30	±0,80	±2,00				
MAS DE 1000 A 2000 mm		±0,50	±1,20	±3,00				

RECAMBIOS MSP-274-R6C

Código máquina:

