

M1 MESAS FRÍAS

COD. PIEZA: **1411120000**

COTAS SIN TOLERANCIA DIN 7168-f

Material: **MATERIAL ESPESOR**

SUSTITUYE A:

Acabado: **ACABADO**

SUSTITUIDO POR:

ANGULAR	GRADO TOLERANCIA	FINO	MEDIO	GRUESO
	HASTA 10 mm		±1°	
MAS DE 10 A 50 mm		±30'		±50'
MAS DE 50 A 120 mm		±20'		±25'
MAS DE 120 A 400 mm		±10'		±15'
MAS DE 400 mm		±5'		±10'

COMÚN A	MODELO	Ud.	MODELO	Ud.	MODELO	Ud.	MODELO	Ud.	MODELO
		MSP-200	1						

LINEAL	GRADO TOLERANCIA	FINO	MEDIO	GRUESO
	HASTA 3 mm		±0,05	±0,10
MAS DE 3 A 6 mm		±0,05	±0,10	±0,20
MAS DE 6 A 30 mm		±0,10	±0,20	±0,50
MAS DE 30 A 120 mm		±0,15	±0,30	±0,80
MAS DE 120 A 400 mm		±0,20	±0,50	±1,20
MAS DE 400 A 1000 mm		±0,30	±0,80	±2,00
MAS DE 1000 A 2000 mm		±0,50	±1,20	±3,00

A4	Nombre	Fecha
Dibujado	MJGG	3-3-03
Modificado		



Escala  
**1:22**

**RECAMBIOS MSP**

Código máquina:  
**CODIGO**

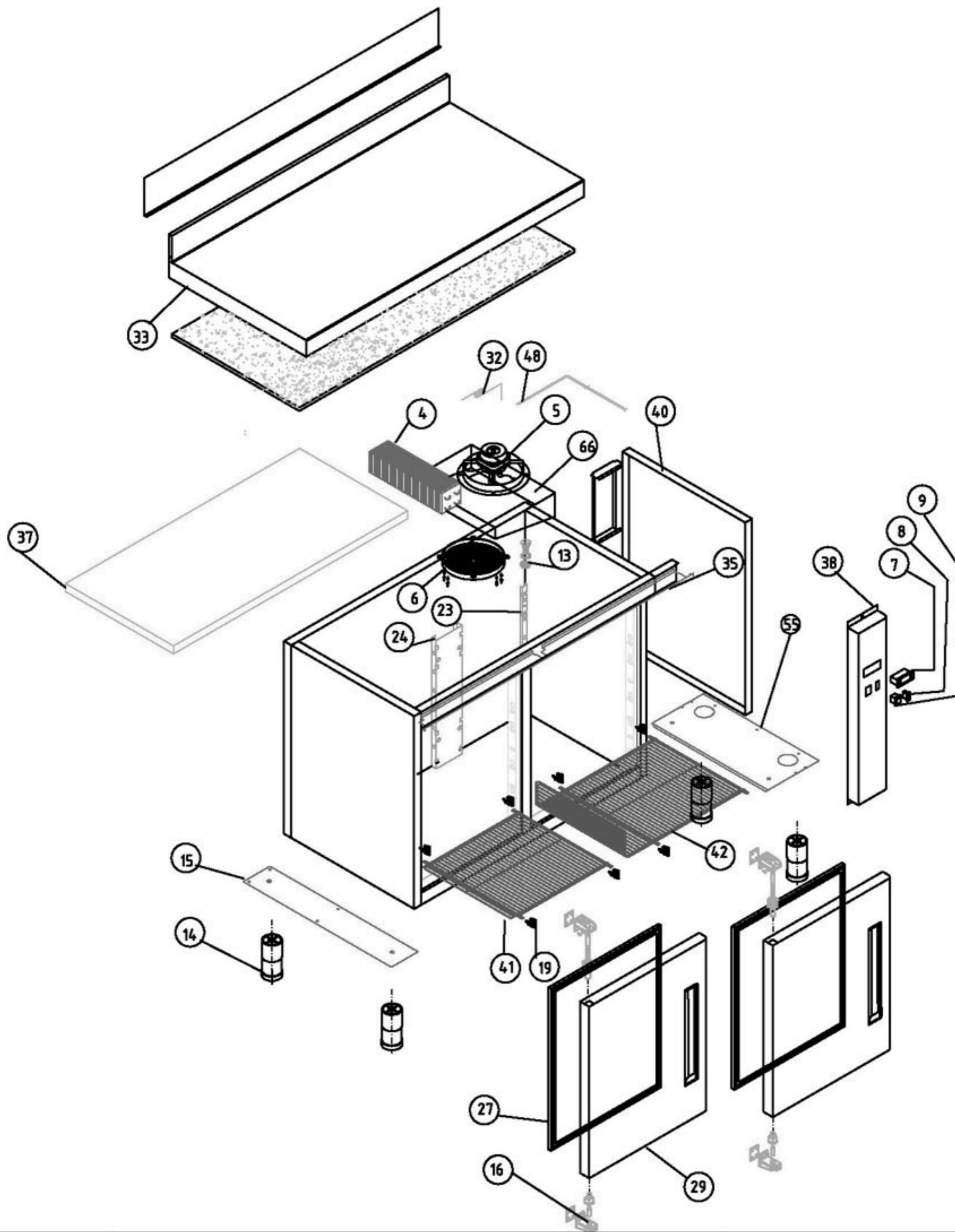

M1 MESAS FRÍAS

COD. PIEZA:

COTAS SIN TOLERANCIA DIN 7168-f

Material: **MATERIAL ESPESOR**

SUSTITUYE A:

Acabado: **ACABADO**

SUSTITUIDO POR:

ANGULAR	GRADO TOLERANCIA	FINO	MEDIO	GRUESO
	HASTA 10 mm		±1°	±1° 30'
	MAS DE 10 A 50 mm		±30'	±50'
	MAS DE 50 A 120 mm		±20'	±25'
	MAS DE 120 A 400 mm		±10'	±15'
MAS DE 400 mm		±5'	±10'	

COMÚN A	MODELO	Ud.	MODELO	Ud.	MODELO	Ud.	MODELO	Ud.	MODELO
	MSP-117-R	1							

LINEAL	GRADO TOLERANCIA	FINO	MEDIO	GRUESO
	HASTA 3 mm	±0,05	±0,10	±0,15
	MAS DE 3 A 6 mm	±0,05	±0,10	±0,20
	MAS DE 6 A 30 mm	±0,10	±0,20	±0,50
	MAS DE 30 A 120 mm	±0,15	±0,30	±0,80
	MAS DE 120 A 400 mm	±0,20	±0,50	±1,20
MAS DE 400 A 1000 mm	±0,30	±0,80	±2,00	
MAS DE 1000 A 2000 mm	±0,50	±1,20	±3,00	

A4	Nombre	Fecha
Dibujado	MJGG	3-3-03
Modificado		



Escala  
1:22

**RECAMBIOS MSP-117 REMOTA**

Código máquina:  
**CODIGO**

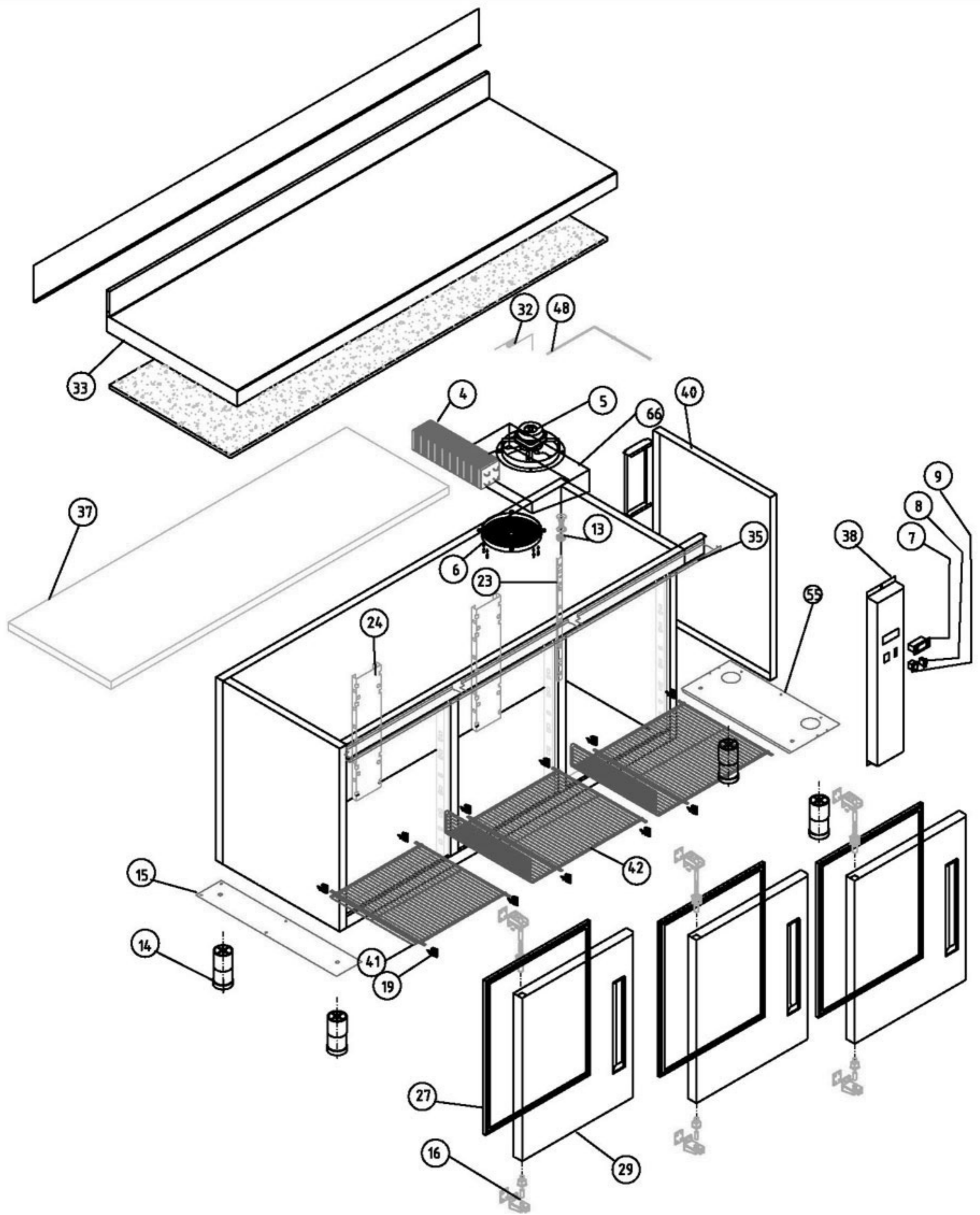

M1 MESAS FRÍAS

COD. PIEZA:

COTAS SIN TOLERANCIA DIN 7168-f

Material: **MATERIAL ESPESOR**

SUSTITUYE A:

Acabado: **ACABADO**

SUSTITUIDO POR:

ANGULAR	GRADO TOLERANCIA	FINO	MEDIO	GRUESO
	HASTA 10 mm		±1°	
MAS DE 10 A 50 mm		±30'		±50'
MAS DE 50 A 120 mm		±20'		±25'
MAS DE 120 A 400 mm		±10'		±15'
MAS DE 400 mm		±5'		±10'

COMÚN A	MODELO	Ud.	MODELO	Ud.	MODELO	Ud.	MODELO	Ud.	MODELO
		MSP-169-R	1						

LINEAL	GRADO TOLERANCIA	FINO	MEDIO	GRUESO
	HASTA 3 mm		±0,05	±0,10
MAS DE 3 A 6 mm		±0,05	±0,10	±0,20
MAS DE 6 A 30 mm		±0,10	±0,20	±0,50
MAS DE 30 A 120 mm		±0,15	±0,30	±0,80
MAS DE 120 A 400 mm		±0,20	±0,50	±1,20
MAS DE 400 A 1000 mm		±0,30	±0,80	±2,00
MAS DE 1000 A 2000 mm		±0,50	±1,20	±3,00

A4	Nombre	Fecha
Dibujado	MJGG	3-3-03
Modificado		
Escala	1:22	

**FAGOR**  
 FAGOFRI s.a.



Código máquina:  
**CODIGO**

**RECAMBIOS MSP-169-R**

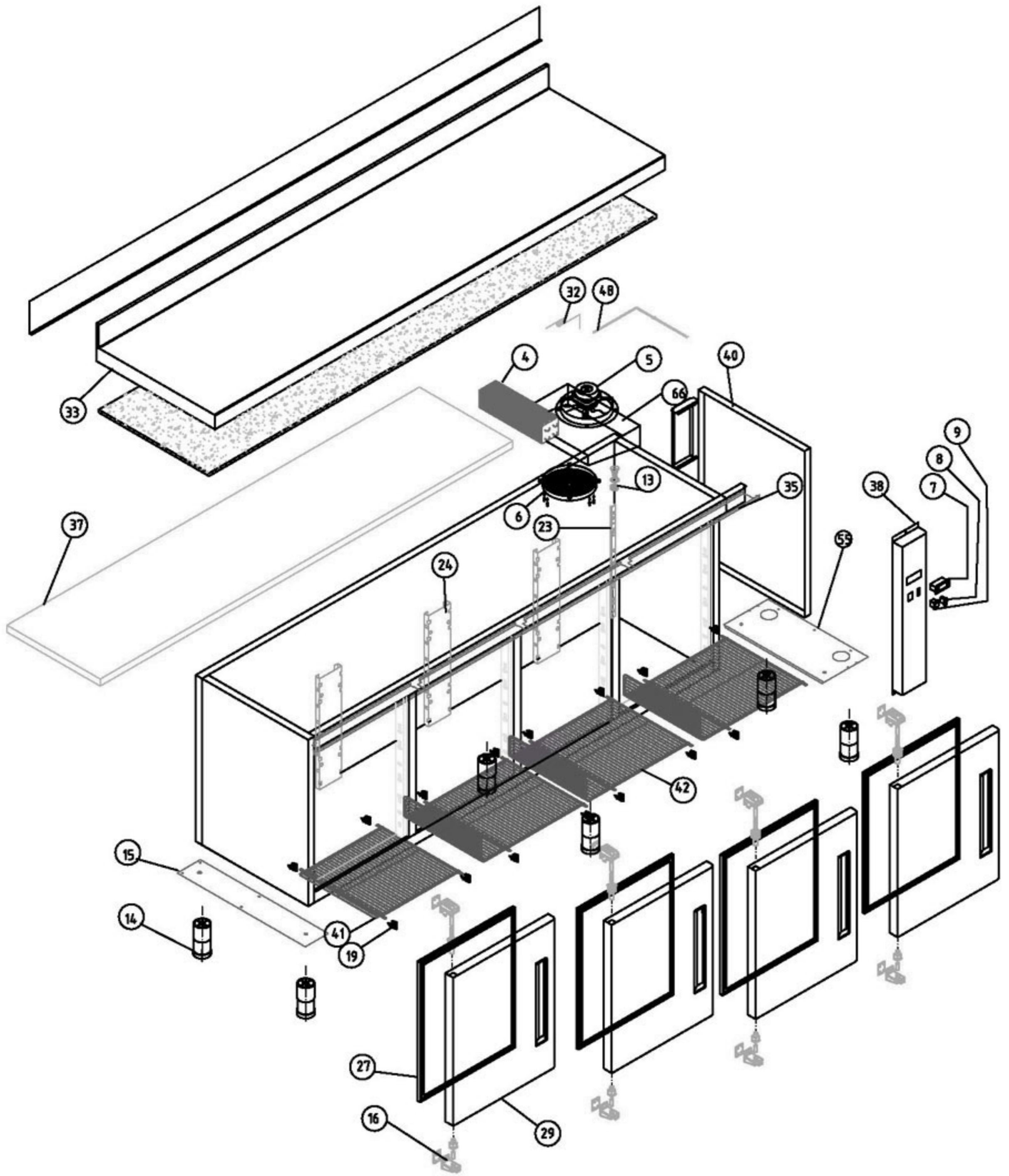

M1 MESAS SNACK

COD. PIEZA:

COTAS SIN TOLERANCIA DIN 7168-f

Material:

SUSTITUYE A:

Acabado:

SUSTITUIDO POR:

ANGULAR	GRADO TOLERANCIA	FINO	MEDIO	GRUESO
	HASTA 10 mm		±1°	±1° 30'
	MAS DE 10 A 50 mm		±30'	±50'
	MAS DE 50 A 120 mm		±20'	±25'
	MAS DE 120 A 400 mm		±10'	±15'
MAS DE 400 mm		±5'	±10'	

COMÚN A

MODELO	Ud.	MODELO	Ud.	MODELO	Ud.	MODELO	Ud.	MODELO	Ud.
MSP-222-R	1								

LINEAL	GRADO TOLERANCIA	FINO	MEDIO	GRUESO
	HASTA 3 mm	±0,05	±0,10	±0,15
	MAS DE 3 A 6 mm	±0,05	±0,10	±0,20
	MAS DE 6 A 30 mm	±0,10	±0,20	±0,50
	MAS DE 30 A 120 mm	±0,15	±0,30	±0,80
	MAS DE 120 A 400 mm	±0,20	±0,50	±1,20
	MAS DE 400 A 1000 mm	±0,30	±0,80	±2,00
MAS DE 1000 A 2000 mm	±0,50	±1,20	±3,00	

A4

Nombre

Fecha

Dibujado

MJGG

1-4-03

Modificado

Escala

1:25

**FAGOR**  
FAGOFRI s.a.



Código máquina:

**RECAMBIOS MSP-222-R**

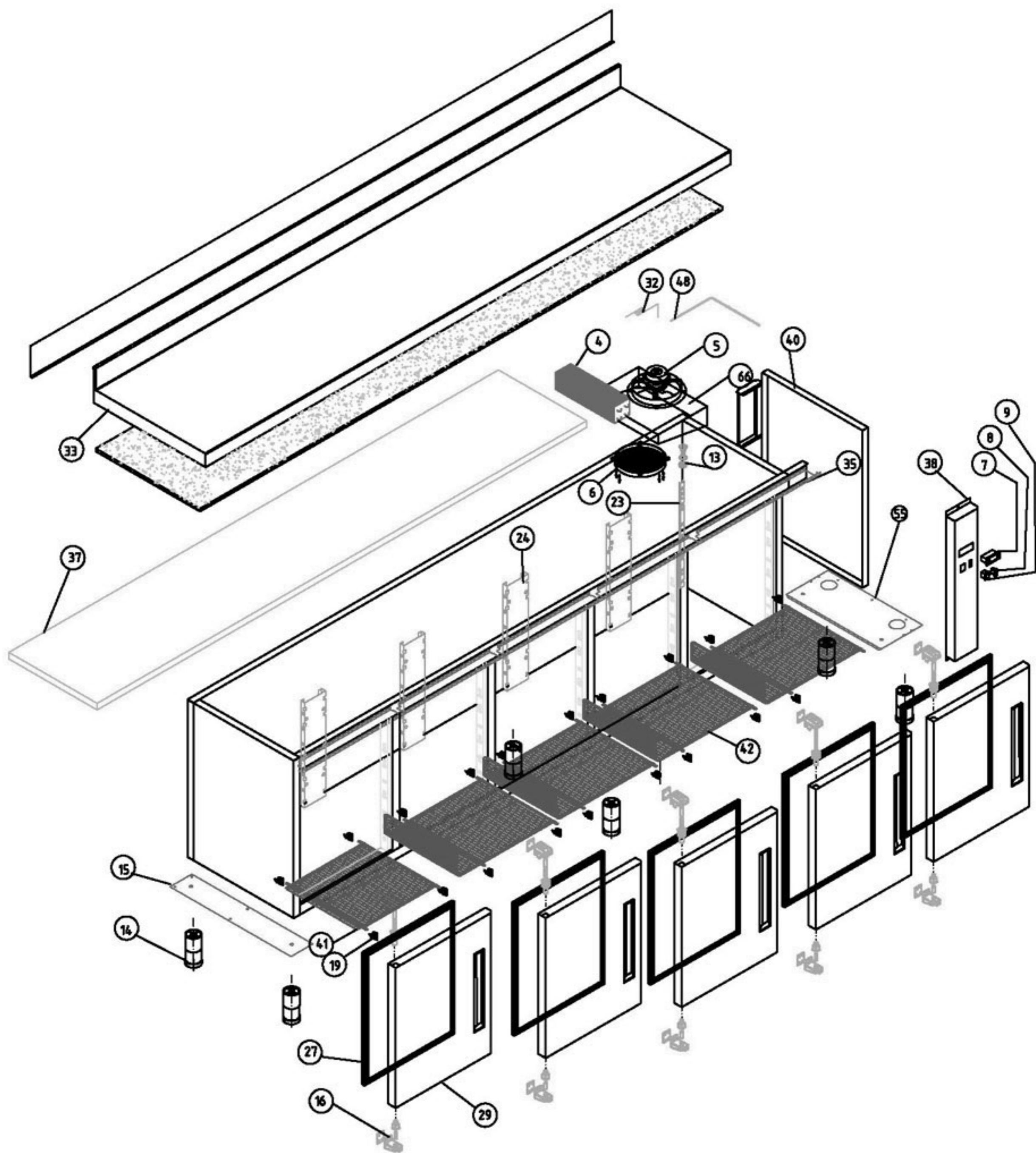

M1 MESAS SNACK

COD. PIEZA:

COTAS SIN TOLERANCIA DIN 7168-f

Material:

SUSTITUYE A:

Acabado:

SUSTITUIDO POR:

ANGULAR	GRADO TOLERANCIA	FINO	MEDIO	GRUESO
	HASTA 10 mm		±1°	
MAS DE 10 A 50 mm		±30'		±50'
MAS DE 50 A 120 mm		±20'		±25'
MAS DE 120 A 400 mm		±10'		±15'
MAS DE 400 mm		±5'		±10'

COMÚN A

MODELO	Ud.	MODELO	Ud.	MODELO	Ud.	MODELO	Ud.
MSP-274-R	1						

LINEAL	GRADO TOLERANCIA	FINO	MEDIO	GRUESO
	HASTA 3 mm		±0,05	±0,10
MAS DE 3 A 6 mm		±0,05	±0,10	±0,20
MAS DE 6 A 30 mm		±0,10	±0,20	±0,50
MAS DE 30 A 120 mm		±0,15	±0,30	±0,80
MAS DE 120 A 400 mm		±0,20	±0,50	±1,20
MAS DE 400 A 1000 mm		±0,30	±0,80	±2,00
MAS DE 1000 A 2000 mm		±0,50	±1,20	±3,00

A4

Nombre

Fecha

Dibujado

MJGG

.19-3-03

Modificado

Escala

1:27

**FAGOR**  
FAGOFRI s.a.



Código máquina:

**RECAMBIOS MSP-274-R**

**RECAMBIOS  
MESAS FRÍAS**

revisión 01-03-2003



FAGOFRI S.A.

MODELOS

MSP-150	MSP-200	MSP-250	MSP-300	MSP-117-R	MSP-169-R	MSP-222-R	MSP-274-R
---------	---------	---------	---------	-----------	-----------	-----------	-----------

Nº	CÓDIGO	DESCRIPCIÓN	SNACK							
1	6021010007	COMPR.FR-8,5 - G R134A		1						
1	6021010015	COMPRESOR GP14 TG			1	1				
1	6021010004	COMPR.FR-7,5-G R134A	1							
2	6021050002	VENTILADOR 10W PATA PALA 220V	1	1	1	1				
3	6029020003	CONDENSADOR 9x3 FAGC0021			1	1				
3	6029020002	CONDENSADOR 9x2	1	1						
4	M129010010	BAT.237/222B8T4R330A S/T(PINT							1	1
4	M129010004	BAT.MFP-270 8T4R330A4SC/TU(PIN			1	1				
4	M129010002	BAT.MFP135 5T4R330A4SC/TUB(PIN	1	1			1	1		
5	6021050001	VENTIL.EVAPOR.5W ARO/TIRO FORZ	1	1	1	1	1	1	1	1
6	6003010035	REJILLA PROTECCION VENTILADOR	1	1	1	1	1	1	1	1
7	6021350015	TERMOSTATO TERM.REFRIG ID 961F	1	1	1	1	1	1	1	1
8	6021130001	INTERRUPTOR BIPOL.AMB.ON/OFF	1	1	1	1	1	1	1	1
9	6021130010	PILOTO RECTAN.AMBAR SEÑAL LUM.	1	1	1	1	1	1	1	1
10	M109050157	CHAPA PROT.MANDOS MESAS FRIAS	1	1	1	1				
11	6003010023	BANDEJA EVAPORACION AUTOMÁTICA	1	1	1	1				
13	6003010034	DESAGÜE SAN MIGUEL	1	1	1	1	1	1	1	1
14	6007050015	PATA REGUL. 50X95 BAJOS	4	4	4	4	4	4	4	4
15	M161250004	BASE PATAS MSP,FMP,MMC PINTADO	1	1	1	1	1	1	1	1
16	V169090001	BISAGRA SISTEMA GIRO A IZDA	2	3	4	5	2	3	4	5
17	6003010048	SOPORTE PUERTA REJILLA	2	2	2	2				
18	6003010032	ESCUADRA AMARRE REJILLA	1	1	1	1				
19	6003010020	SOPORTE PARRILLA	8	12	16	20	8	12	16	20
21	6003010181	REJ.RESP.GRUPO 387X280POLICARB	1	1	1	1				
23	M109050080	CREMALL. LAT. POST. MSP	2	2	2	2	2	2	2	2
24	M109050081	CREMALLERA CENTRAL MSP	1	2	3	4	1	2	3	4
25	M109050153	CREMALLERA MFP-MSP 576X66 MM	4	6	8	10	4	6	8	10
27	6045010009	BURLETE 475X605 MSP	2	3	4	5	2	3	4	5
29	M169010010	PUERTA MSP/MPP IZDA TIR.ABS	2	3	4	5	2	3	4	5
32	V107020005	CAPILAR 1.25x2100			1	1				
32	M107020001	CAPILAR 1x3300	1	1						
33	M181010008	ENCIMERA MSP/FMP274								1
33	M181010007	ENCIMERA MSP/FMP222							1	
33	M181010005	ENCIMERA MSP/FMP117					1			
33	M181010004	ENCIMERA MSP/FMP300				1				
33	M181010003	ENCIMERA MSP/FMP250			1					
33	M181010001	ENCIMERA MSP/FMP150	1							
33	M181010002	ENCIMERA MSP/FMP200		1						
33	M181010006	ENCIMERA MSP/FMP169						1		
35	M109250026	PROTECT. ENCIM. 150	1				1			
35	M109250027	PROTECT. ENCIM. 200		1				1		
35	M109250028	PROTECT. ENCIM. 250			1	1			1	1
35	M109250030	PROTECT. ENCIM. SUPLE. 300				1				1
36	6001050034	AGLOM.3060X550X13 ENC. MSP-300				1				1
36	6001050033	AGLOM.2540X550X13 ENC. MSP-250			1				1	
36	6001050021	AGLOM.1490X550X13 ENC. MSP-150	1				1			
37	6013050003	PL.POLIEST.1535X466X30 TIPO IV		1	1	1		1	1	
38	M109010334	REJILLA CUADRO ABS GRIS MSP	1	1	1	1				
38	M109010335	CUADRO DE MANDOS MSN-R R7					1	1	1	1
40	M109010134	COST EXT LAD GRUP MSP	1	1	1	1				
40	M109010237	COST.EXT.LAD.GRUP.REMOTO MSP					1	1	1	1
41	6027010002	PARRILLA PLANA 433x442	1	1	1	1	1	1	1	1
42	6027010001	PARRILLA MSP C/P 513x442	1	2	3	4	1	2	3	4
46	6047010003	FILTRO DESHIDRAT.40GR 1/4X1/4	1	1	1	1				
48	6021350013	SONDA TERMOST.REF NTC 15KOhm	1	1	1	1	1	1	1	1
50	6003010105	CUADRO ABS GRIS	1	1	1	1				
55	6037050003	SOPORTE COST.RODAP.MSP 230X500					1	1	1	1
66	6003050002	GAVETA TIRO FORZADO SNACK	1	1	1	1	1	1	1	1
67	6021010045	RELE ARRANQUE COMPRESOR FR-7,5-G 6001	1							
67	6021010017	RELE COMPRESOR GP-14TG RF 5127			1	1				
67	6021010025	RELE ARRANQUE COMPRESOR FR-8,5G		1						
68	6021010041	CONDENS.ARRANQ GL-TG 47 microF			1	1				
68	6021010037	CONDENSADOR ARRANQUE FR 17U5015 80microF	1	1						

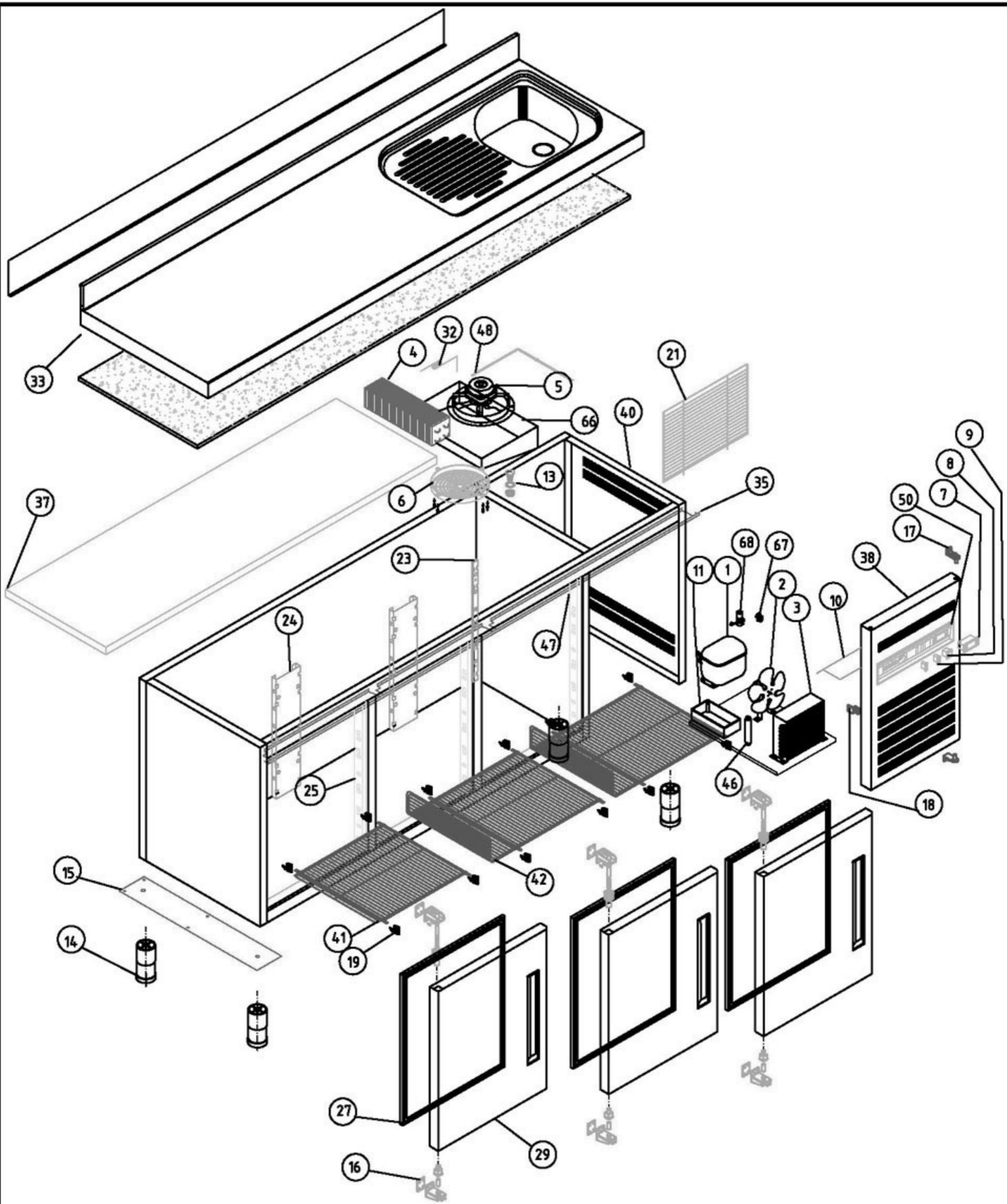

M1 MESAS FRÍAS

COD. PIEZA:

COTAS SIN TOLERANCIA DIN 7168-f

Material: **MATERIAL ESPESOR**

SUSTITUYE A:

Acabado: **ACABADO**

SUSTITUIDO POR:

ANGULAR	GRADO TOLERANCIA	FINO	MEDIO	GRUESO
	HASTA 10 mm		±1°	
MAS DE 10 A 50 mm		±30'		±50'
MAS DE 50 A 120 mm		±20'		±25'
MAS DE 120 A 400 mm		±10'		±15'
MAS DE 400 mm		±5'		±10'

LINEAL	GRADO TOLERANCIA	FINO	MEDIO	GRUESO
	HASTA 3 mm		±0,05	±0,10
MAS DE 3 A 6 mm		±0,05	±0,10	±0,20
MAS DE 6 A 30 mm		±0,10	±0,20	±0,50
MAS DE 30 A 120 mm		±0,15	±0,30	±0,80
MAS DE 120 A 400 mm		±0,20	±0,50	±1,20
MAS DE 400 A 1000 mm		±0,30	±0,80	±2,00
MAS DE 1000 A 2000 mm		±0,50	±1,20	±3,00

COMÚN A	MODELO	Ud.	MODELO	Ud.	MODELO	Ud.	MODELO	Ud.	MODELO
		MSP-200-F	1						

A4	Nombre	Fecha
Dibujado	MJGG	3-3-03
Modificado		



Escala  
1:22

**RECAMBIOS MSP CON FREGADERO**

Código máquina:  
**CODIGO**

# RECAMBIOS MESAS FRÍAS

revisión 01-03-2003



FAGOFRI S.A.

MODELOS

MSP-150-F

MSP-200-F

MSP-250-F

MSP-300-F

Nº	CÓDIGO	DESCRIPCIÓN	SNACK			
			MSP-150-F	MSP-200-F	MSP-250-F	MSP-300-F
1	6021010007	COMPR.FR-8,5 - G R134A		1		
1	6021010015	COMPRESOR GP14 TG			1	1
1	6021010004	COMPR.FR-7,5-G R134A	1			
2	6021050002	VENTILADOR 10W PATA PALA 220V	1	1	1	1
3	6029020003	CONDENSADOR 9x3 FAGC0021			1	1
3	6029020002	CONDENSADOR 9x2	1	1		
4	M129010004	BAT.MFP-270 8T4R330A4SC/TU(PIN			1	1
4	M129010002	BAT.MFP135 5T4R330A4SC/TUB(PIN	1	1		
5	6021050001	VENTIL.EVAPOR.5W ARO/TIRO FORZ	1	1	1	1
6	6003010035	REJILLA PROTECCION VENTILADOR	1	1	1	1
7	6021350015	TERMOSTATO TERM.REFRIG ID 961F	1	1	1	1
8	6021130001	INTERRUPTOR BIPOL.AMB.ON/OFF	1	1	1	1
9	6021130010	PILOTO RECTAN.AMBAR SEÑAL LUM.	1	1	1	1
10	M109050157	CHAPA PROT.MANDOS MESAS FRIAS	1	1	1	1
11	6003010023	BANDEJA EVAPORACION AUTOMÁTICA	1	1	1	1
13	6003010034	DESAGÜE SAN MIGUEL	1	1	1	1
14	6007050015	PATA REGUL. 50X95 BAJOS	4	4	4	4
15	M161250004	BASE PATAS MSP,FMP,MMC PINTADO	1	1	1	1
16	V169090001	BISAGRA SISTEMA GIRO A IZDA	2	3	4	5
17	6003010048	SOPORTE PUERTA REJILLA	2	2	2	2
18	6003010032	ESCUADRA AMARRE REJILLA	1	1	1	1
19	6003010020	SOPORTE PARRILLA	8	12	16	20
21	6003010181	REJ.RESP.GRUPO 387X280POLICARB	1	1	1	1
23	M109050080	CREMALL. LAT. POST. MSP	2	2	2	2
24	M109050081	CREMALLERA CENTRAL MSP	1	2	3	4
25	M109050153	CREMALLERA MFP-MSP 576X66 MM	4	6	8	10
27	6045010009	BURLETE 475X605 MSP	2	3	4	5
29	M169010010	PUERTA MSP/MPP IZDA TIR.ABS	2	3	4	5
32	V107020005	CAPILAR 1.25x2100			1	1
32	M107020001	CAPILAR 1x3300	1	1		
33	M181010044	ENCIMERA CON FREGADERO MSP-200		1		
33	M181010043	ENCIMERA CON FREGADERO MSP-150	1			
33	M181010045	ENCIMERA CON FREGADERO MSP-250			1	
33	M181010046	ENCIMERA CON FREGADERO MSP-300				1
35	M109250026	PROTECT. ENCIM. 150	1			
35	M109250027	PROTECT. ENCIM. 200		1		
35	M109250028	PROTECT. ENCIM. 250			1	1
35	M109250030	PROTECT. ENCIM. SUPLE. 300				1
36	6001050034	AGLOM.3060X550X13 ENC. MSP-300				1
36	6001050033	AGLOM.2540X550X13 ENC. MSP-250			1	
36	6001050021	AGLOM.1490X550X13 ENC. MSP-150	1			
37	6013050003	PL.POLIEST.1535X466X30 TIPO IV		1		
38	M109010334	REJILLA CUADRO ABS GRIS MSP	1	1	1	1
40	M109010134	COST EXT LAD GRUP MSP	1	1	1	1
41	6027010002	PARRILLA PLANA 433x442	1	1	1	1
42	6027010001	PARRILLA MSP C/P 513x442	1	2	3	4
46	6047010003	FILTRO DESHIDRAT.40GR 1/4X1/4	1	1	1	1
48	6021350013	SONDA TERMOST.REF NTC 15KOhm	1	1	1	1
50	6003010105	CUADRO ABS GRIS	1	1	1	1
66	6003050002	GAVETA TIRO FORZADO SNACK	1	1	1	1
67	6021010045	RELE ARRANQUE COMPRESOR FR-7,5-G 6001	1			
67	6021010017	RELE COMPRESOR GP-14TG RF 5127			1	1
67	6021010025	RELE ARRANQUE COMPRESOR FR-8,5G		1		
68	6021010041	CONDENS.ARRANQ GL-TG 47 microF			1	1
68	6021010037	CONDENSADOR ARRANQUE FR 17U5015 80microF	1	1		



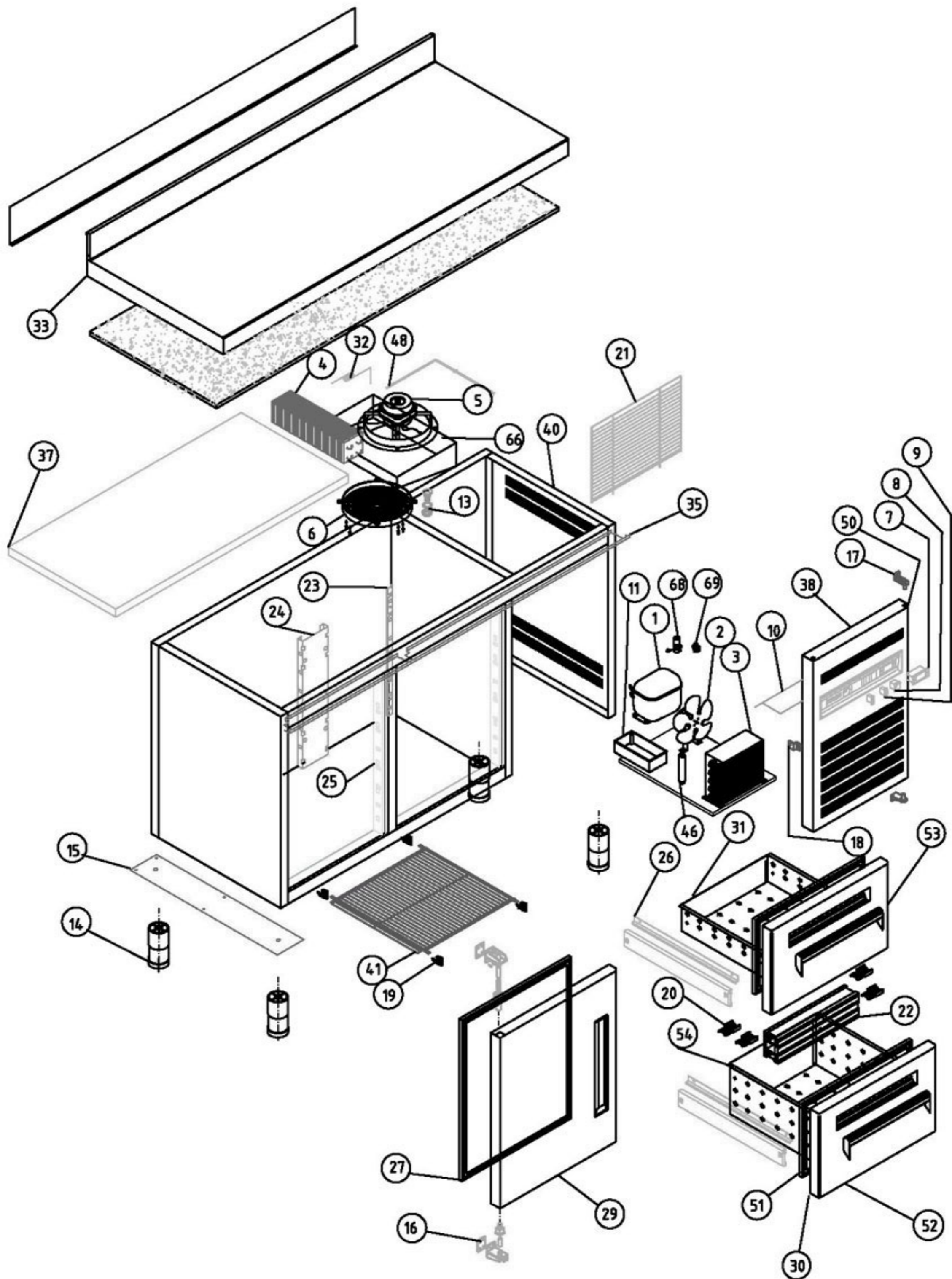

M1 MESAS FRÍAS

COD. PIEZA:

COTAS SIN TOLERANCIA DIN 7168-f

Material: **MATERIAL ESPESOR**

SUSTITUYE A:

Acabado: **ACABADO**

SUSTITUIDO POR:

GRADO TOLERANCIA	FINO			MEDIO			GRUESO		
HASTA 10 mm	±1°			±1° 30'					
MAS DE 10 A 50 mm	±30'			±50'					
MAS DE 50 A 120 mm	±20'			±25'					
MAS DE 120 A 400 mm	±10'			±15'					
MAS DE 400 mm	±5'			±10'					

COMÚN A

MODELO	Ud.	MODELO	Ud.	MODELO	Ud.	MODELO	Ud.
MSP-150-2C	1						

GRADO TOLERANCIA	FINO			MEDIO			GRUESO		
HASTA 3 mm	±0,05			±0,10			±0,15		
MAS DE 3 A 6 mm	±0,05			±0,10			±0,20		
MAS DE 6 A 30 mm	±0,10			±0,20			±0,50		
MAS DE 30 A 120 mm	±0,15			±0,30			±0,80		
MAS DE 120 A 400 mm	±0,20			±0,50			±1,20		
MAS DE 400 A 1000 mm	±0,30			±0,80			±2,00		
MAS DE 1000 A 2000 mm	±0,50			±1,20			±3,00		

A4	Nombre	Fecha
Dibujado	MJGG	3-3-03
Modificado	.	.



Escala	1:22
--------	------

RECAMBIOS MSP-150-2C

Código máquina:

CODIGO

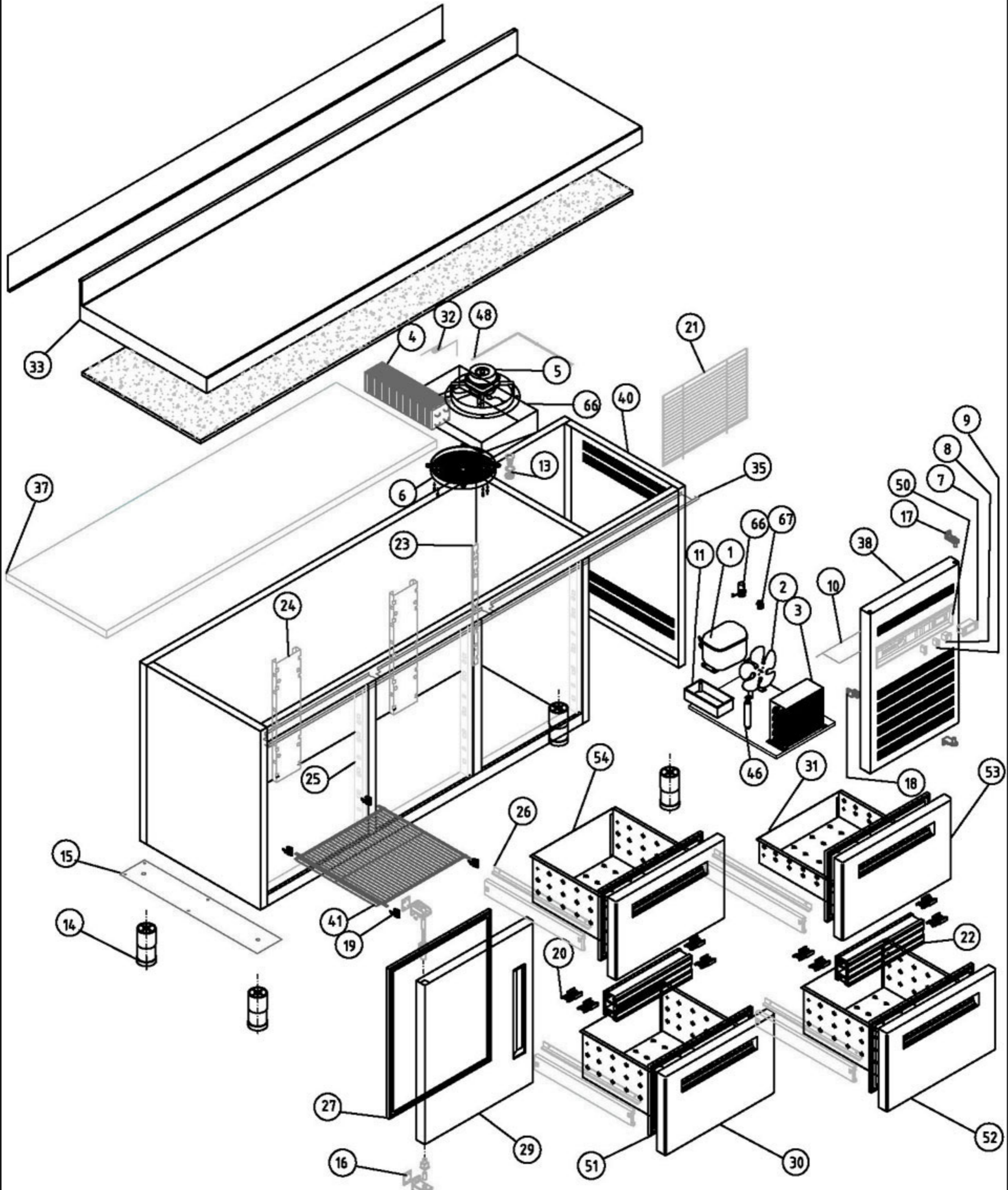

M1 MESAS FRÍAS

COTAS SIN TOLERANCIA DIN 7168-f

Material: **MATERIAL ESPESOR**

Acabado: **ACABADO**

COD. PIEZA:

SUSTITUYE A:

SUSTITUIDO POR:

ANGULAR	GRADO TOLERANCIA	FINO	MEDIO	GRUESO
	HASTA 10 mm		±1°	
MAS DE 10 A 50 mm		±30'		±50'
MAS DE 50 A 120 mm		±20'		±25'
MAS DE 120 A 400 mm		±10'		±15'
MAS DE 400 mm		±5'		±10'

COMÚN A	MODELO	Ud.	MODELO	Ud.	MODELO	Ud.	MODELO	Ud.	MODELO
		MSP-200-4C	1						

LINEAL	GRADO TOLERANCIA	FINO	MEDIO	GRUESO
	HASTA 3 mm	±0,05	±0,10	±0,15
	MAS DE 3 A 6 mm	±0,05	±0,10	±0,20
	MAS DE 6 A 30 mm	±0,10	±0,20	±0,50
	MAS DE 30 A 120 mm	±0,15	±0,30	±0,80
	MAS DE 120 A 400 mm	±0,20	±0,50	±1,20
MAS DE 400 A 1000 mm	±0,30	±0,80	±2,00	
MAS DE 1000 A 2000 mm	±0,50	±1,20	±3,00	

A4	Nombre	Fecha
Dibujado	MJGG	3-3-03
Modificado		



Escala  
1:22

**RECAMBIOS MSP - 200 - 4C**

Código máquina:

**CODIGO**

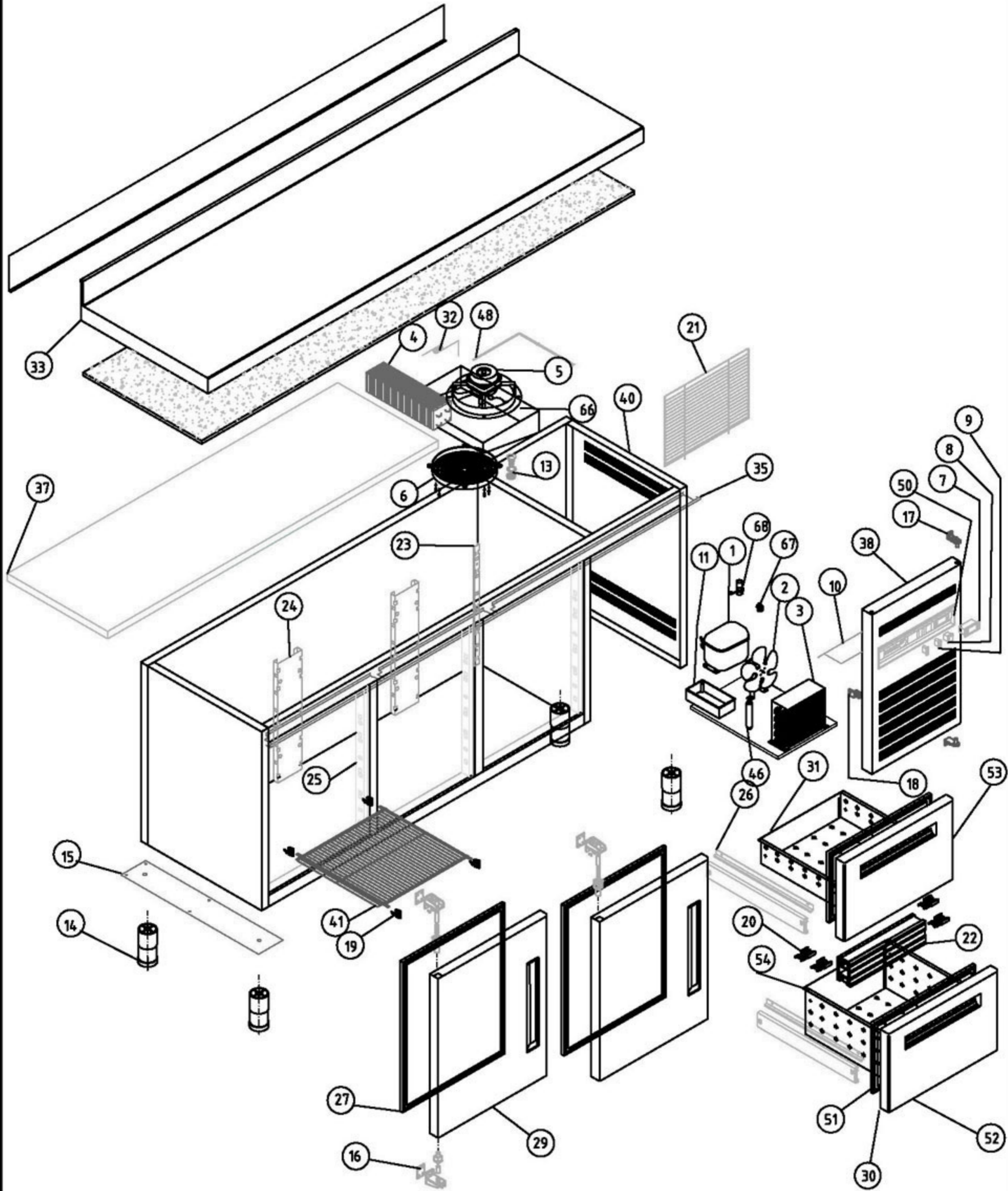

M1 MESAS FRÍAS

COD. PIEZA:  
SUSTITUYE A:  
SUSTITUIDO POR:

COTAS SIN TOLERANCIA DIN 7168-f

Material: **MATERIAL ESPESOR**

Acabado: **ACABADO**

ANGULAR	GRADO TOLERANCIA	FINO	MEDIO	GRUESO
	HASTA 10 mm		±1°	
MAS DE 10 A 50 mm		±30'		±50'
MAS DE 50 A 120 mm		±20'		±25'
MAS DE 120 A 400 mm		±10'		±15'
MAS DE 400 mm		±5'		±10'

COMÚN A	MODELO	Ud.	MODELO	Ud.	MODELO	Ud.	MODELO	Ud.	MODELO
		MSP-200-2C	1						

LINEAL	GRADO TOLERANCIA	FINO	MEDIO	GRUESO
	HASTA 3 mm		±0,05	±0,10
MAS DE 3 A 6 mm		±0,05	±0,10	±0,20
MAS DE 6 A 30 mm		±0,10	±0,20	±0,50
MAS DE 30 A 120 mm		±0,15	±0,30	±0,80
MAS DE 120 A 400 mm		±0,20	±0,50	±1,20
MAS DE 400 A 1000 mm		±0,30	±0,80	±2,00
MAS DE 1000 A 2000 mm		±0,50	±1,20	±3,00

A4 Nombre Fecha  
Dibujado MJGG 3-3-03  
Modificado .

Escala 1:22



RECAMBIOS MSP-200-2C

Código máquina:  
**CODIGO**

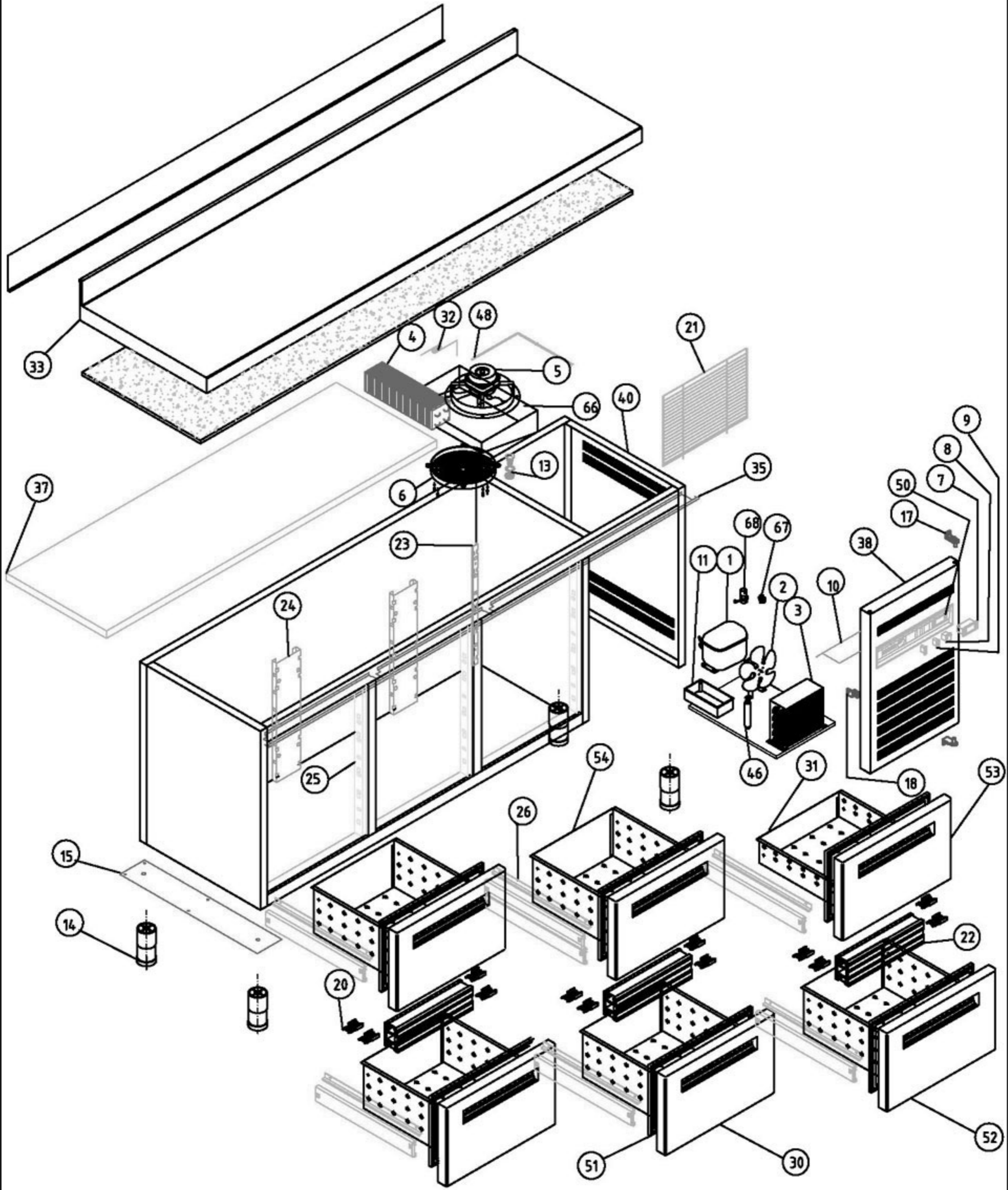

M1 MESAS FRÍAS

COD. PIEZA:

COTAS SIN TOLERANCIA DIN 7168-f

Material: **MATERIAL ESPESOR**

SUSTITUYE A:

Acabado: **ACABADO**

SUSTITUIDO POR:

ANGULAR	GRADO TOLERANCIA	FINO	MEDIO	GRUESO
	HASTA 10 mm		±1°	
MAS DE 10 A 50 mm		±30'		±50'
MAS DE 50 A 120 mm		±20'		±25'
MAS DE 120 A 400 mm		±10'		±15'
MAS DE 400 mm		±5'		±10'

COMÚN A	MODELO	Ud.	MODELO	Ud.	MODELO	Ud.	MODELO	Ud.	MODELO
		MSP-200-6C	1						

LINEAL	GRADO TOLERANCIA	FINO	MEDIO	GRUESO
	HASTA 3 mm		±0,05	±0,10
MAS DE 3 A 6 mm		±0,05	±0,10	±0,20
MAS DE 6 A 30 mm		±0,10	±0,20	±0,50
MAS DE 30 A 120 mm		±0,15	±0,30	±0,80
MAS DE 120 A 400 mm		±0,20	±0,50	±1,20
MAS DE 400 A 1000 mm		±0,30	±0,80	±2,00
MAS DE 1000 A 2000 mm		±0,50	±1,20	±3,00

A4	Nombre	Fecha
Dibujado	MJGG	3-3-03
Modificado	.	.



Escala 1:22

RECAMBIOS MSP - 200 - 6C

Código máquina:  
**CODIGO**



