

**RECAMBIOS
MSP-150-4C**

9/06/2008





F A G O R I

COD. 148111140000

N.	CODIGO	DENOMINACION	CANTIDAD
1	6003010326	DESAG COMPL 3/4 GRIS+TUERCA	1
2	6003010262	TAPON DESAGÜE DE 3/4 CIEGO	1
3	6003010327	JUNTA GOMA DESAGÜE 3/4	1
4	M181010393	ENCIM.MSP-150 PETO	1
5	M109170858	PROTECT.TRASER.MSP150	1
6	6033090086	JUEGO TAPETAS ENCIM.ZAMAK	1
7	M109050260	SOPOR.SUP.PUERTAS MSP-150	1
8	6007050017	PATA REGULAB ARM GASTRO	4
9	6025050010	TORN 4.8x25 ZINC DIN 7981	16
15	M177010059	REJILL.CUAD.MANDOS MSP	1
16	M109050532	PROTECC.INST.ELECT.FAGOR	1
17	6033090090	SOPORTE ZAMAK GIRO REJILLA	1
18	6033090064	EJE30x10VARIL INOX ROSC.INT M6	1
19	M177010065	CHAP.CUAD.MAND.FAG.	1
20	6023010408	PEG.CUAD.FAGOR REFR.347,5X60	1
21	M173010068	UD.COND.MSP,MPP150,MFP135	1
22	6021010004	COMPR.FR-7,5-G R134A	1
23	6029020002	CONDENSADOR 9x2	1
24	6021050002	VENTILADOR 10W PATA PALA 220V	1
25	6021310003	VALVULA OBUS COMPLETA RF.HB-1S	1
26	6047010003	FILTRO DESHIDRAT.40GR 1/4X1/4	1
27	M107010037	SERP.EV.AUTOM.1/4 PINT.150,200	1
28	6003010023	BANDEJA EVAPORACION AUTOMÁTICA	1
29	M109250127	OMEGA COND.9X2-REJ.MESAS-ARMAR	1
30	M177130026	CUAD ELEC.BAJOS FRIO	1
31	6021130001	INT.BIP.AMB.O/I CONTAC.REFORZ.	1
32	6021350018	TERMOS REFRI CAREL PYCO1RN515	1
33	6021410028	INST.ELE.MESA REF.CARE	1
34	M171010067	UD.EVAPORAT.MSP-150	1
35	6029010088	BAT.6T3R330A4SMFP06 C/TUB PIN	1
36	M109050033	PROT SONDA 175x49	1
37	6003010181	REJ.RESP.GRUPO 387X280POLICARB	1
38	M109170829	BASE PATAS MSP/FMP/MMC	1
39	6003010033	DESA.1/2 PULG.CUELL CORT+TUERC	1
42	M171010065	GAVET+REJILL+VENTILAD MSP	1
43	6021050001	VENTIL.EVAPOR.5W ARO/TIRO FORZ	1

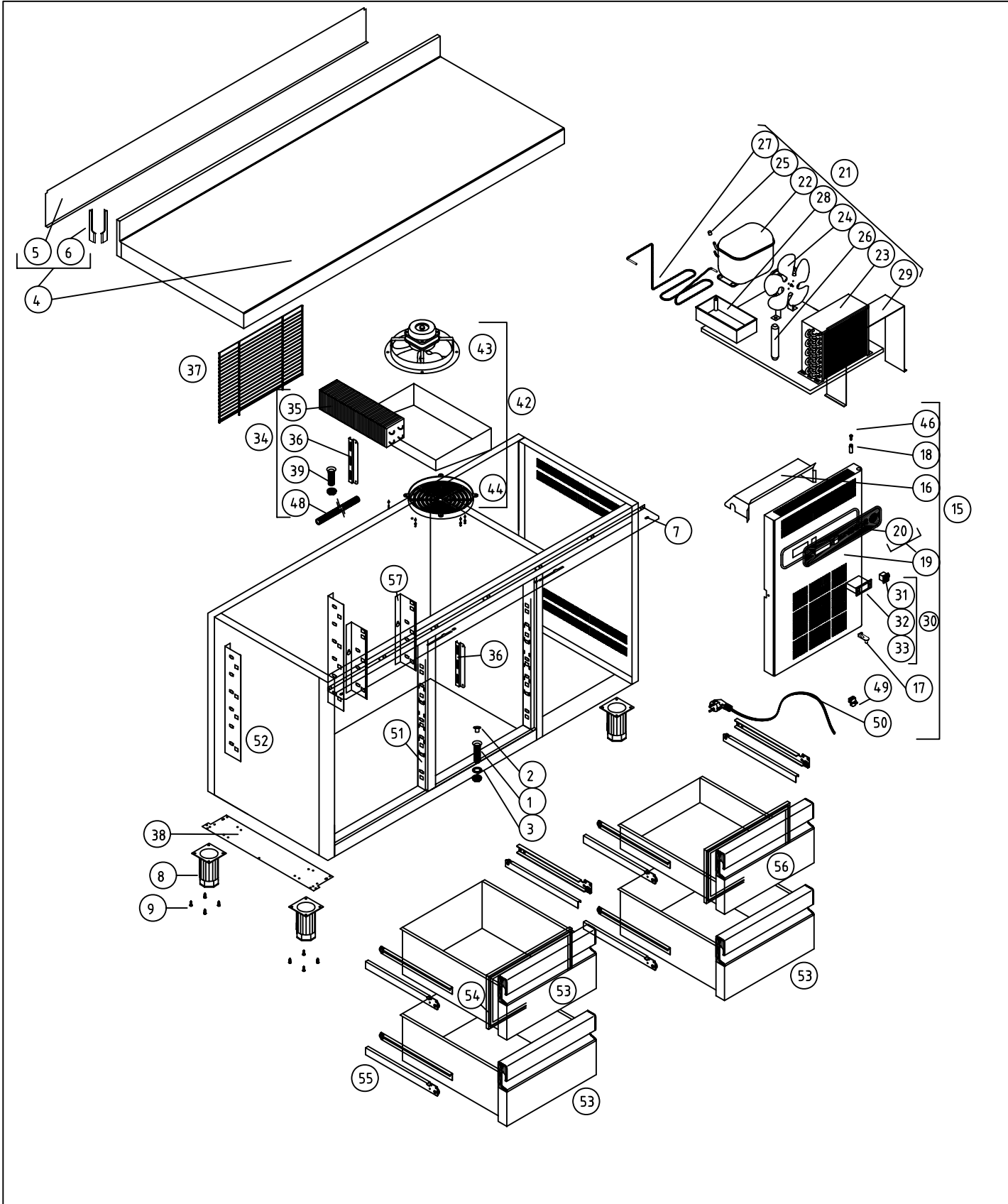
44	6003010035	REJILLA PROTECCION VENTILADOR	1
46	6025090027	TORN M6X10 INOX EXAGONAL	1
48	6003010417	TUBO DESAG.BUFLEX D.INT=17MM	1
49	6003010068	PISACABLES DE 90°	1
50	6021390006	MANG 3X1X2500 BL. SCHUKO 3T	1
51	M109050277	CREMALLERA MARCO PUERTA MSP CAJ.	4
52	M109050278	CREMA.IZDA. RESP. MSP-CAJ	2
53	M169120097	CAJON MSP 1/2	3
54	6045010118	BURLETE 460x265 CAJON 1/2 MSP	4
55	6033050007	GUIA DE ACERO L4450 BRILLO (JUEGO)	4
56	M169120099	CAJON MSP 1/2 LADO GRUPO	1
57	M109050280	CREMALLERA DCHA. L.GRUPO MSP CAJ	2



M1 MESAS FRÍAS				COD. PIEZA: 14811114.0000									
COTAS SIN TOLERANCIA DIN 7168-f				Material: MATERIAL ESPESOR									
				Acabado: ACABADO									
ANGULAR	GRADO TOLERANCIA	FINO	MEDIO	GRUESO	SUSTITUYE A:								
	HASTA 10 mm		±1°	±1° 30'	SUSTITUIDO POR:								
	MÁS DE 10 A 50 mm	±30'		±50'	MODELO	Ud.	MODELO	Ud.	MODELO	Ud.	MODELO	Ud.	
	MÁS DE 50 A 120 mm	±20'		±25'	MSP-150-4C	1							
MÁS DE 120 A 400 mm	±10'		±15'										
MÁS DE 400 mm	±5'		±10'										
LINEAL	GRADO TOLERANCIA	FINO	MEDIO	GRUESO	COMUN A								
	HASTA 3 mm	±0,05	±0,10	±0,15	A4	Nombre	Fecha	 F A G O F R I					
	MÁS DE 3 A 6 mm	±0,05	±0,10	±0,20	Dibujado	JJVM	25/04/2008						
	MÁS DE 6 A 30 mm	±0,10	±0,20	±0,50	Modificado								
	MÁS DE 30 A 120 mm	±0,15	±0,30	±0,80	Escala	1:22		RECAMBIOS MSP-150-4C					
	MÁS DE 120 A 400 mm	±0,20	±0,50	±1,20			Código máquina: CODIGO						
MÁS DE 400 A 1000 mm	±0,30	±0,80	±2,00										
MÁS DE 1000 A 2000 mm	±0,50	±1,20	±3,00										