

DESPIECES

MESAS MPZ1



Rev.: Feb-2011

**RECAMBIOS
MESAS MPZ1
FEB-2011**



MODELOS

MPZ1-135	MPZ1-180	MPZ1-225
----------	----------	----------

Nº	CÓDIGO	DESCRIPCIÓN	MPZ1-135	MPZ1-180	MPZ1-225
1	6003010326	DESAG COMPL 3/4 GRIS+TUERCA	1	1	1
2	6003010262	TAPON DESAGÜE DE 3/4 CIEGO	1	1	1
3	6003010327	JUNTA GOMA DESAGÜE 3/4	1	1	1
4	M181010609	ENCIM.C/EXPOSITOR.INC.MPZ1-150	1		
4	M181010611	ENCIM.C/EXPOSITOR.INC.MPZ1-200		1	
4	M181010613	ENCIM.C/EXPOSITOR.INC.MPZ1-250			1
5	M109011088	TAPA CUBETAS MPZ1-150	1		
5	M109011096	TAPA CUBETAS MPZ1-200		2	
5	M109011097	TAPA CUBETAS MPZ1-250			2
7	6007050091	PERNO ROSCADO TAPA ENSALADERA	4	8	8
8	6025130001	TUERCA INOX M6 CIEGA	4	8	8
9	6007050017	PATA REGULAB ARM GASTRO	4	4	6
10	M169010093	PUERTA MFP/MFN FAGOR	2	3	4
11	6045010119	BURLETE MFP 399X585 MFP	2	3	4
12	6003010136	CAJA ALOJAMIENTO MUELLE GRIS	2	3	4
13	6033010100	BIS.TRS1D DOBL MUELLE DV-2608	2	3	4
14	6033010129	SOP.BISAG.INF.IZD.	2	3	4
15	6033090104	EJE ROSCA EXT.30X10INOX MESAS	2	3	4
16	6025130045	TUERC.RAPIDA TRT M6-2	3	4	5
17	M109050552	SOPOR.SUP.PUERTAS MFP-135	1		
17	M109050242	SOP.SUP.PUERTAS MFP-180		1	1
18	M109050555	SOP.SUP.PUERT. MFP-225			1
20	M177010065	CHAP.CUAD.MANDOS	1	1	1
21	M109050532	PROTECC.INST.ELECT.FAGOR	1	1	1
22	6033090090	SOPORTE ZAMAK GIRO REJILLA	1	1	1
23	6033090104	EJE ROSCA EXT.30X10INOX MESAS	1	1	1
24	6023010408	PEG.CUAD.FAGOR REFR.347,5X60	1	1	1
25	6021130001	INT.BIP.AMB.O/I CONTAC.REFORZ.	1	1	1
26	6021350018	TERMOS REFRI CAREL PYCO1RN515	1	1	1
30	6021010007	COMPR.FR-8.5-G R134A	1		
30	6021010154	COMP.NEK6210Z EMBRACO		1	1
31	6029020002	CONDENSADOR 9x2	1		
31	6029020003	CONDENSADOR 9x3 FAGC0021		1	1
32	6021050002	VENTILADOR 10W PATA PALA 220V	1	1	1
33	6021310003	VALVULA OBUS COMPLETA RF.HB-1S	1	1	1
34	6047010003	FILTRO DESHIDRAT.40GR 1/4X1/4	1	1	1
35	M107010003	SERPENT EVAP.AUT.MEP-135 PINT	1	1	1
36	M109050019	BANDEJA EVAP AUT MEP-135/180	1	1	1
37	M109250127	OMEGA COND.9X2-REJ.MESAS-ARMAR	1	1	1

**RECAMBIOS
MESAS MPZ1
FEB-2011**



MODELOS

MPZ1-135	MPZ1-180	MPZ1-225
----------	----------	----------

Nº	CÓDIGO	DESCRIPCIÓN	MPZ1-135	MPZ1-180	MPZ1-225
40	6029010125	BAT.5T4R330A4S MEP135,180 PINT	1	1	1
41	6021050008	VENTILADOR 120X120 CON BOLAS	2	4	4
42	6003010051	JUNTA GOMA DESAGUE 1/2	2	4	4
43	6003010034	DESAGÜE SAN MIGUEL+TUERCA	1	2	2
44	M109050606	BANDEJA DESAG.MEP135,180	1	2	2
45	M109050692	COST.EVAP.DCH.MPZ1 LADO GRUPO	1	1	1
46	M109050693	COST.EVAP.IZD.MPZ1 LADO GRUPO	1	1	1
47	M109050696	TAPA CAJA EVAP.MPZ1	1	2	2
48	6041090017	REJ.AIREACIÓN 15X15 7022 ALUM.	2	4	4
49	6029010140	BAT.5T4R330A4S MEP180 PIN S/TU		1	1
50	6033050015	GUIA SNAK.DT.CONG-MESA GN562mm	8	12	16
51	6027010003	PARRIL. GN1/1 530x325	2	3	4
52	M109050298	CREMALL.LATER.DCHA.MFP	1	1	1
53	M109050299	CREMALL.LAT.IZDA.MFP	1	1	1
54	M109050611	CREMAL.CENTRAL MEP135,180	1	2	2
55	M109050747	CREM. MARC. MAGNETICO MSP-MFP	4	6	8
56	M109050300	CREMALL.RESP.DCHA.MFP			1
57	M109050301	CREMALL.RESP.IZDA.MFP			1
60	6003010181	REJ.RESP.GRUPO 387X280POLICARB	1	1	1
61	6021390006	MANG 3X1X2500 BL. SCHUKO 3T	1	1	1
62	M109050033	PROT SONDA 175x49	1	1	1
70	6021010037	CONDEN.ARRANQUE FR-117U5015 80 mF	1		
70	6021010158	CONDENSADOR COMP. NEK 6210Z		1	1
71	6021010025	RELE ARRANQUE COMPRESOR FR-8,5G 2	1		
71	6021010156	RELE ARRAN. COMP. NEK 6210Z		1	1
80	6021250003	RESIST.MARCO GASTRO-1,20W	1	1	1
81	6021250004	RESIST.MARCO GASTRO-2, 20 W	1	2	3
90	6033010122	TIR.ZAMAK ARCO REF:PX.748-1	1	2	2
93	M109050694	COS.EV.DCH.MPZ1-200 LAD.NO GRU		1	1
94	M109050695	COS.EV.IZD.MPZ1-200 LAD.NO GRU		1	1
95	M109050672	SOP.TAPA MPZ1/MEP DCHO.	1	2	2
96	M109050671	SOP.TAPA MPZ1/MEP IZDO.	1	2	2

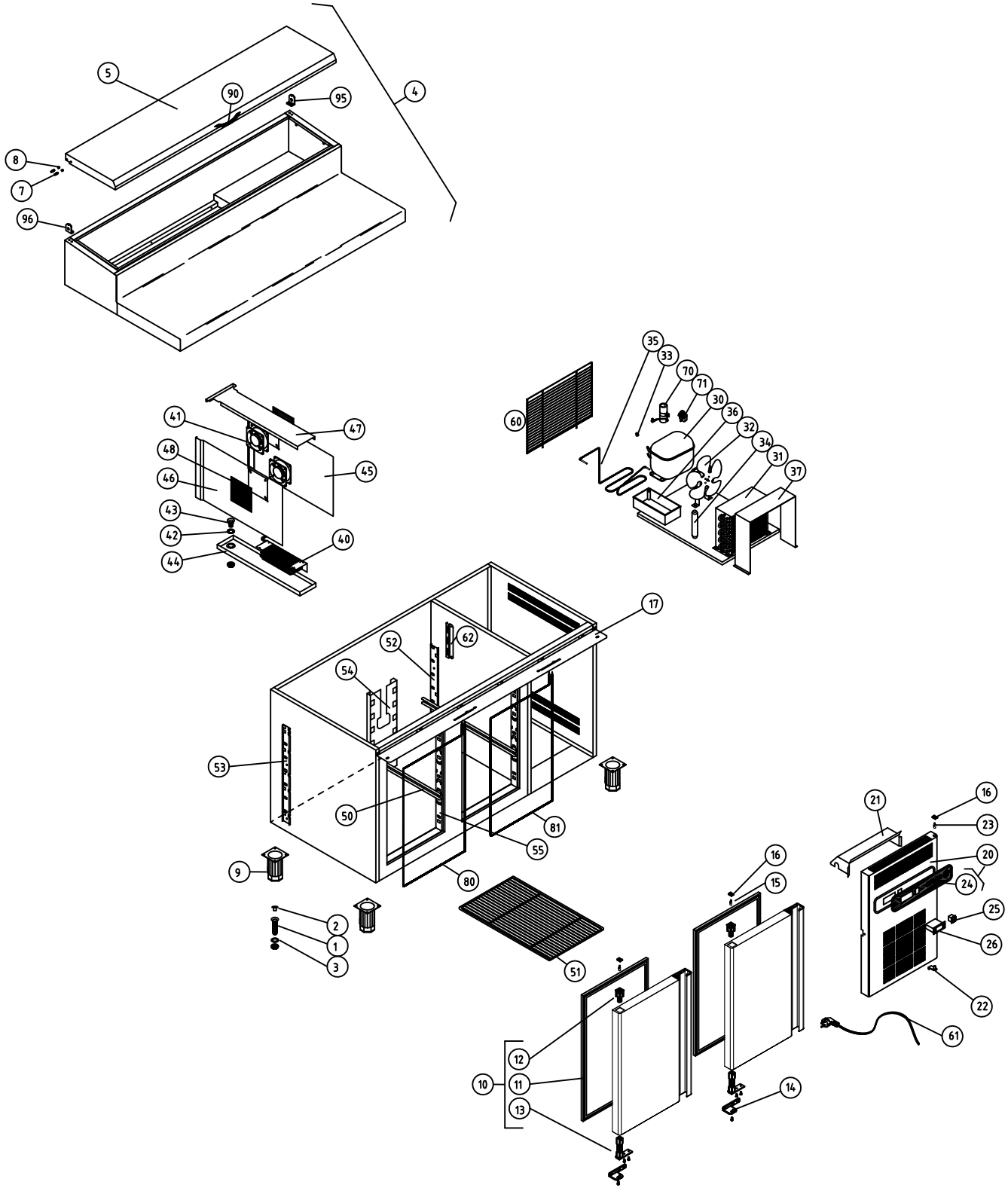

COTAS SIN TOLERANCIA DIN 7168-f					Material:				COD. PIEZA: 148612000000			
ANGULAR	GRADO TOLERANCIA	FINO	MEDIO	GRUESO	Acabado:				SUSTITUYE A:			
	HASTA 10 mm	±1°		±1° 30'	SUSTITUIDO POR:							
	MAS DE 10 A 50 mm	±30'		±50'	MODELO	Ud.	MODELO	Ud.	MODELO	Ud.	MODIFICACION Nº	RESPONSABLE
	MAS DE 50 A 120 mm	±20'		±25'	MPZ1-135	1					2	A.J.GONZALEZ
	MAS DE 120 A 400 mm	±10'		±15'								
MAS DE 400 mm	±5'		±10'							FECHA: Feb-2011		
LINEAL	GRADO TOLERANCIA	FINO	MEDIO	GRUESO	A4	Nombre		Fecha		 F A G O F R I		
	HASTA 3 mm	±0,05	±0,10	±0,15	Dibujado	M.J.GRANADOS		.17-2-09				
	MAS DE 3 A 6 mm	±0,05	±0,10	±0,20	Escala	1:30		RECAMBIOS MPZ1-135				
	MAS DE 6 A 30 mm	±0,10	±0,20	±0,50								
	MAS DE 30 A 120 mm	±0,15	±0,30	±0,80								
MAS DE 120 A 400 mm	±0,20	±0,50	±1,20		Código máquina:							
MAS DE 400 A 1000 mm	±0,30	±0,80	±2,00									
MAS DE 1000 A 2000 mm	±0,50	±1,20	±3,00									

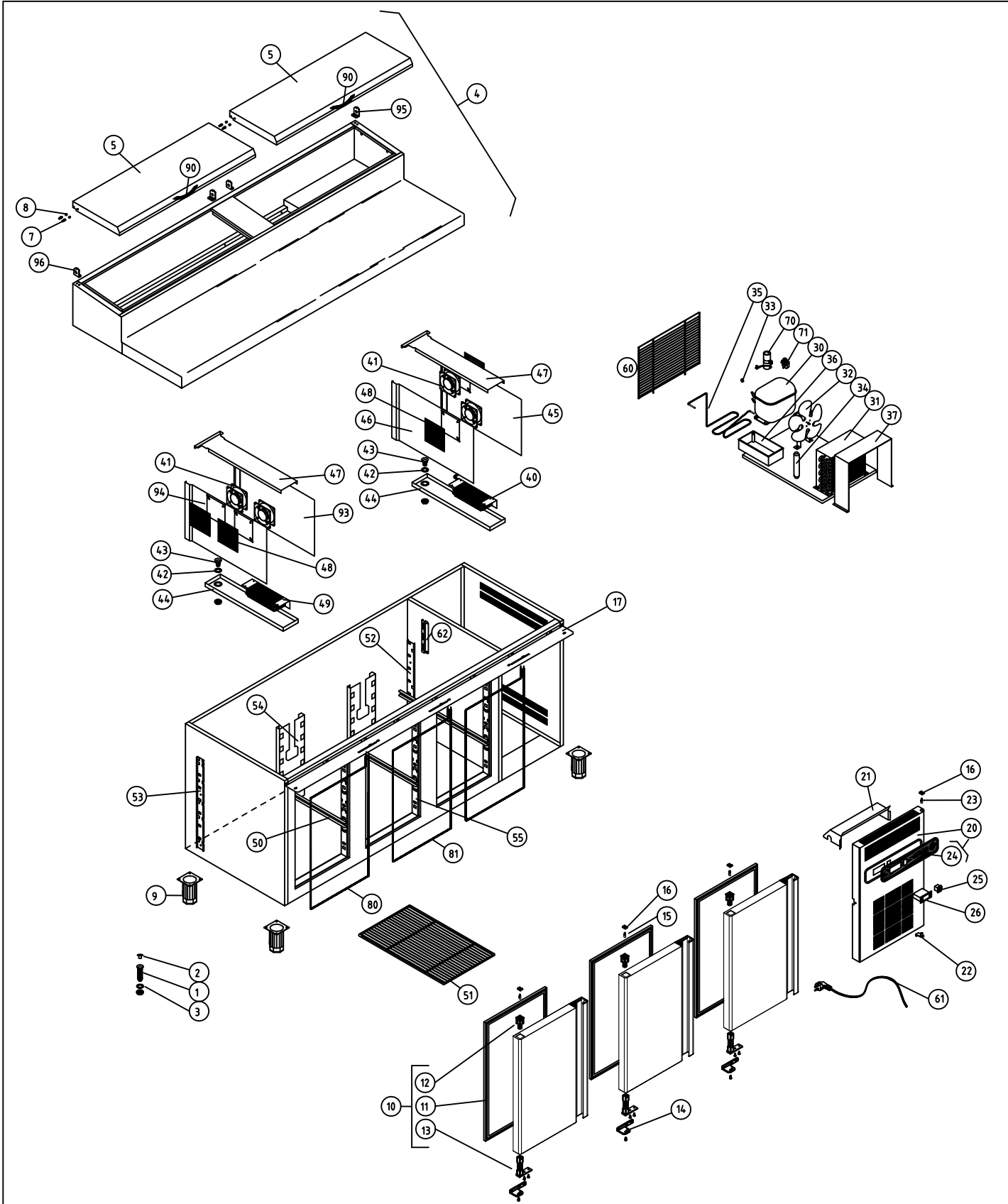

COTAS SIN TOLERANCIA DIN 7168-f				Material:				COD. PIEZA: 148613000000						
ANGULAR	GRADO TOLERANCIA	FINO	MEDIO	GRUESO	Acabado:				SUSTITUYE A:					
	HASTA 10 mm		±1°	±1° 30'	SUSTITUIDO POR:									
	MÁS DE 10 A 50 mm	±30'		±50'										
	MÁS DE 50 A 120 mm	±20'		±25'										
LINEAL	MÁS DE 120 A 400 mm	±10'		±15'										
	MÁS DE 400 mm	±5'		±10'										
	MÁS DE 3 mm	±0,05	±0,10	±0,15										
	MÁS DE 3 A 6 mm	±0,05	±0,10	±0,20										
MÁS DE 6 A 30 mm	±0,10	±0,20	±0,50											
MÁS DE 30 A 120 mm	±0,15	±0,30	±0,80											
MÁS DE 120 A 400 mm	±0,20	±0,50	±1,20											
MÁS DE 400 A 1000 mm	±0,30	±0,80	±2,00											
MÁS DE 1000 A 2000 mm	±0,50	±1,20	±3,00											
Material:					Acabado:					COD. PIEZA: 148613000000				
Material:					Acabado:					SUSTITUYE A:				
Material:					Acabado:					SUSTITUIDO POR:				
COMUN A		MODELO	Ud.	MODELO	Ud.	MODELO	Ud.	MODIFICACION Nº	RESPONSABLE					
COMUN A		MPZ1-180	1					2	A.J.GONZALEZ					
COMUN A								FECHA: Feb-2011						
A4		Nombre			Fecha			 F A G O F R I						
Dibujado		M.J.GRANADOS			.17-2-09									
Escala		1:30			RECAMBIOS MPZ1-180			Código máquina:						

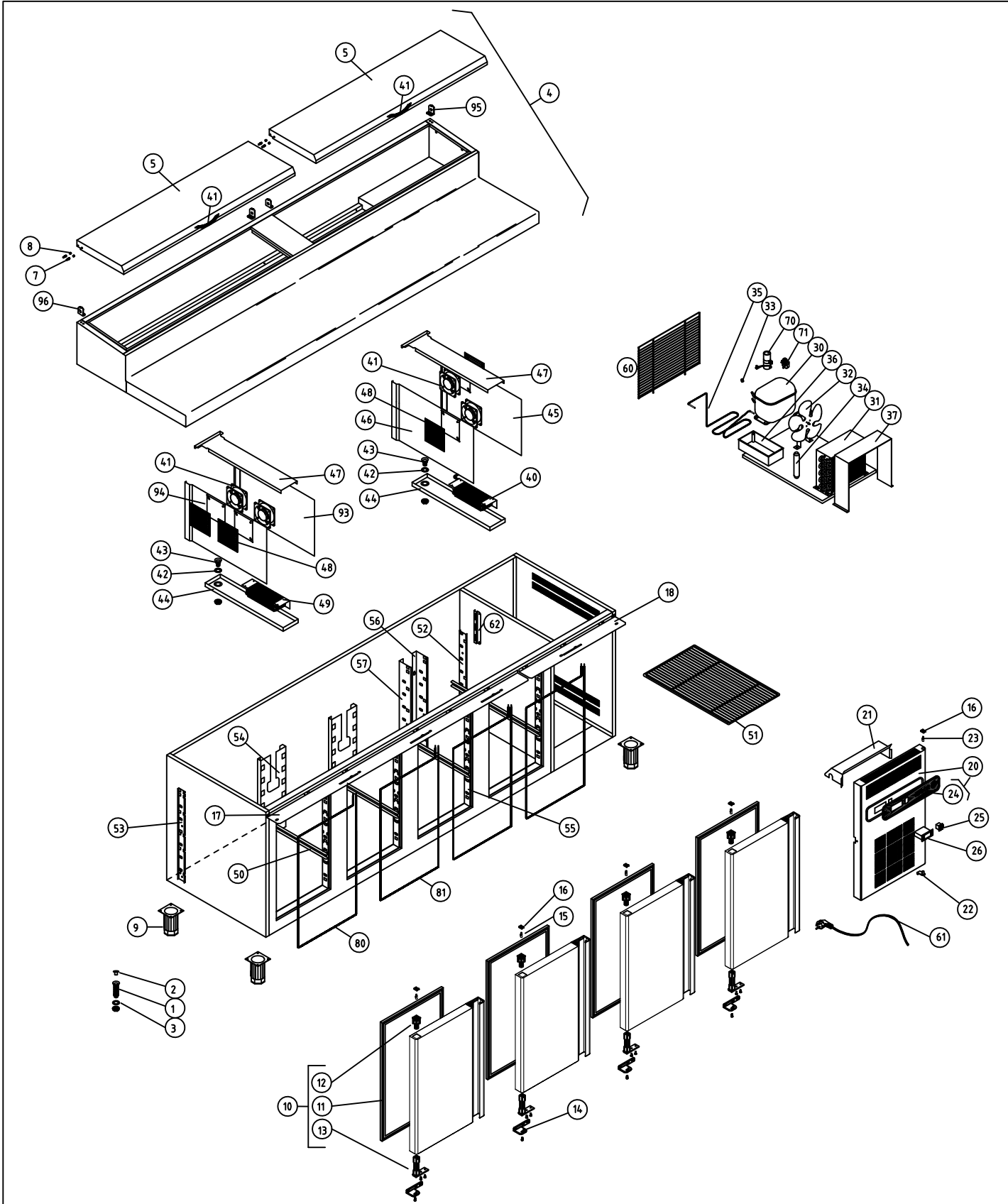

COTAS SIN TOLERANCIA DIN 7168-f				Material:				COD. PIEZA: 148614000000				
GRADO TOLERANCIA				Acabado:				SUSTITUYE A:				
FINO				SUSTITUIDO POR:								
MEDIO												
GRUESO												
ANGULAR	HASTA 10 mm	±1°	±1° 30'	COMUN A	MODELO	Ud.	MODELO	Ud.	MODELO	Ud.	MODIFICACION Nº	RESPONSABLE
	MÁS DE 10 A 50 mm	±30'	±50'		MPZ1-225	1					2	A.J.GONZALEZ
	MÁS DE 50 A 120 mm	±20'	±25'									
	MÁS DE 120 A 400 mm	±10'	±15'									
MÁS DE 400 mm	±5'	±10'										
				FECHA: Feb-2011								
LINEAL	GRADO TOLERANCIA	FINO	MEDIO	GRUESO	A4	Nombre	Fecha					
	HASTA 3 mm	±0,05	±0,10	±0,15	Dibujado	M.J.GRANADOS	.17-2-09					
	MÁS DE 3 A 6 mm	±0,05	±0,10	±0,20	Escala	1:30		RECAMBIOS MPZ1-225		Código máquina:		
	MÁS DE 6 A 30 mm	±0,10	±0,20	±0,50								
MÁS DE 30 A 120 mm	±0,15	±0,30	±0,80									
MÁS DE 120 A 400 mm	±0,20	±0,50	±1,20									
MÁS DE 400 A 1000 mm	±0,30	±0,80	±2,00									
MÁS DE 1000 A 2000 mm	±0,50	±1,20	±3,00									