

DESPIECES

MESAS MPP

PASTELERIA



Rev.: Dic-2010

RECAMBIOS
MESAS
PASTELERIA
DIC-2010



MODELOS

Nº	CÓDIGO	DESCRIPCIÓN	MPP-150	MPP-202	MPP-255	MPP-307	MPP-117-R	MPP-169-R	MPP-307-R	MPP-150-C	MPP-202-C	MPP-255-C	MPP-169-R/C	MPP-222-R/C
1	6003010326	DESAG COMPL 3/4 GRIS+TUERCA	1	1	1	1	1	1	1	1	1	1	1	1
2	6003010262	TAPON DESAGÜE DE 3/4 CIEGO	1	1	1	1	1	1	1	1	1	1	1	1
3	6003010327	JUNTA GOMA DESAGÜE 3/4	1	1	1	1	1	1	1	1	1	1	1	1
4	M181010440	ENCIM.MPP-150 PETO	1											
4	M181010483	ENCIM.MPP-202 PETO		1										
4	M181010485	ENCIM.MPP-250 PETO			1									
4	M181010487	ENCIM.MPP-307 PETO				1								
4	M181010579	ENCIM.MPP-117-R PETO					1							
4	M181010525	ENCIM.MPP-169-R PETO						1						
4	M181010582	ENCIM.MPP-274-R PETO							1					
4	M181010495	ENCIM.MPP-150 CENTRAL								1				
4	M181010538	ENCIM.MPP-202 CENTRAL									1			
4	M181010497	ENCIM.MPP-255 CENTRAL										1		
4	M181010570	ENCIM.MPP-169-R CENTRAL											1	
4	M181010627	ENCIM.MPP-222-R CENTRAL												1
5	M109170858	PROT.TRAS.ENC.MSP-150	1											
5	M109170859	PROT.TRAS.ENC.MSP-200		1	1	1								
5	M109170862	PROT.TRAS.ENC.MSP-117					1							
5	M109170863	PROT.TRAS.ENC.MSP-169						1	1					
6	6033090086	JUEGO TAPETAS ENCIM.ZAMAK	1	1	1	1	1	1	1					
7	M109170860	PROT.TRAS.ENC.MSP-250			1									
7	M109170861	PROT.TRAS.ENC.MSP-300-274 SUPL				1			1					
9	6007050017	PATA REGULAB ARM GASTRO	4	4	6	6	4	4	6	4	4	6	4	6
10	M169010088	PUE MSP/MSN AP.IZDA	2	3	4	5	2	3	5	2	3	4	3	4
11	6045010115	BURLETE 465X585 UR-260 MSP	2	3	4	5	2	3	5	4	6	8	6	8
12	6003010136	CAJA ALOJAMIENTO MUELLE GRIS	2	3	4	5	2	3	5	4	6	8	6	8
13	6033010100	BIS.TRS1D DOBL MUELLE DV-2608	2	3	4	5	2	3	5	4	6	8	6	8
14	6033010129	SOP.BISAG.INF.IZD.	2	3	4	5	2	3	5	2	3	4	3	4
15	6033090104	EJE ROSCA EXT.30X10INOX MESAS	2	3	4	5	2	3	5	4	6	8	6	8
16	6025130045	TUERC.RAPIDA TRT M6-2	2	3	4	5	2	3	5	6	8	10	8	10
17	M109050260	SOPOR.SUP.PUERTAS MSP-150	1							1				
17	M109050266	SOP.SUP.PUER.MSP20-25-30		1		1					1	1		
17	M109050269	SOP.SUP.PUERT.MSP-250			1									
17	M109050529	SOP.SUP.PUERTAS MSP117R					1							
17	M109050372	SOP.SUP.PUERTAS MSP169R						1					1	
17	M109050374	SOP.SUP.PUERTAS MSP274R							1					
17	M109050373	SOPORT.SUP.PUER.MSP-222-R												1
18	M109050272	SOPORT.SUP.PUERTAS MSP300				1								
18	M109050269	SOP.SUP.PUERT.MSP-250										2		
19	M109050682	SOP.SUP.PUERTAS MSP-150 GI								1				
19	M109050683	SOP.SUP.PUERTA MSP-200 GI									1	1		
19	M109050697	SOP.SUP.PUERTAS MSP-169-R GI											1	
19	M109050723	SOP.SUP.PUERTAS MSP-222-R GI												1
20	M177010065	CHAP.CUAD.MANDOS	1	1	1	1				1	1	1		
20	M109010642	CUADRO MANDOS MSP-R					1	1	1				1	1
21	M109050532	PROTECC.INST.ELECT.FAGOR	1	1	1	1				1	1	1		
22	6033090090	SOPORTE ZAMAK GIRO REJILLA	1	1	1	1				2	2	2		
23	6033090104	EJE ROSCA EXT.30X10INOX MESAS	1	1	1	1				2	2	2		
24	6023010408	PEG.CUAD.FAGOR REFR.347,5X60	1	1	1	1				1	1	1		
24	6023010418	PEG.105X220 CUADR.REMOT FAGOR					1	1	1				1	1
25	6021130001	INT.BIP.AMB.O/I CONTAC.REFORZ.	1	1	1	1	1	1	1	1	1	1	1	1
26	6021350018	TERMOS REFRI CAREL PYCO1RN515	1	1	1	1	1	1	1	1	1	1	1	1
27	6021130010	PILOTO RECTAN.AMBAR LUM.FAGOR					1	1	1				1	1
28	M177010087	CH.REJ.CUAD TRAS.FAGOR								1	1	1		

RECAMBIOS
MESAS
PASTELERIA
DIC-2010



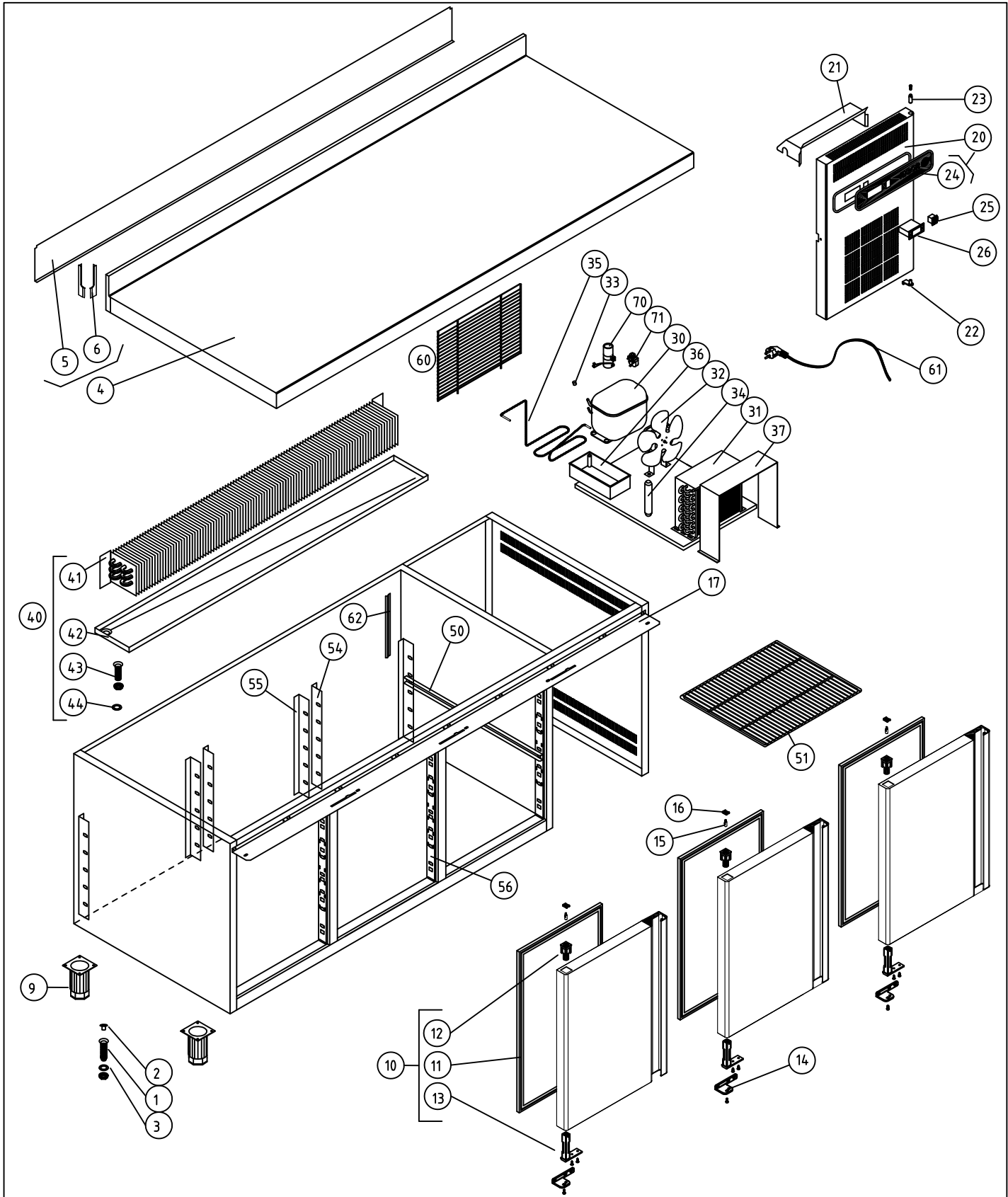

MODELOS

Nº	CÓDIGO	DESCRIPCIÓN	MPP-150	MPP-202	MPP-255	MPP-307	MPP-117-R	MPP-169-R	MPP-307-R	MPP-150-C	MPP-202-C	MPP-255-C	MPP-169-R/C	MPP-222-R/C
28	M177010093	REJ.TRAS.CUADRO REMOTO											1	1
30	6021010004	COMPR.FR-7,5-G R134A	1							1				
30	6021010007	COMPR.FR-8.5-G R134A		1							1			
30	6021010154	COMP.NEK6210Z EMBRACO			1	1						1		
31	6029020002	CONDENSADOR 9x2	1	1						1	1			
31	6029020003	CONDENSADOR 9x3 FAGC0021			1	1						1		
32	6021050002	VENTILADOR 10W PATA PALA 220V	1	1	1	1				1	1	1		
33	6021310003	VALVULA OBUS COMPLETA RF.HB-1S	1	1	1	1				1	1	1		
34	6047010003	FILTRO DESHIDRAT.40GR 1/4X1/4	1	1	1	1				1	1	1		
35	M107010037	SERP.EV.AUTOM.1/4 PINT.150,200	1	1	1	1				1	1	1		
36	6003010023	BANDEJA EVAPORACION AUTOMÁTICA	1	1	1	1				1	1	1		
37	M109250127	OMEGA COND.9X2-REJ.MESAS-ARMAR	1	1	1	1				1	1	1		
40	M171010017	UD.EVAP.MSP,MPP-150 ESTATICO	1											
40	M171010018	UD.EVAPORAT.MSP-200 ESTATICO		1										
40	M171010019	UD.EVAPORAT.MSP-250 ESTATICO			1									
40	M171010020	UD.EVAPORAT.MSP-300 ESTATICO				1								
40	M171010130	UD. EVAP. MPP-117-R ESTATICO					1							
40	M171010132	UD. EVAP. MPP-169-R ESTATICO						1					1	
40	M171010135	UD. EVAP. MPP-274-R ESTATICO							1					
40	M171010021	UD.EVAPORAT.MPP-150-C ESTATICO								1				
40	M171010022	UD.EVAPORAT.MPP-200-C ESTATICO									1			
40	M171010023	UD.EVAPORAT.MPP-250-C ESTATICO										1		
40	M171010133	UD. EVAP. MPP-222-R ESTATICO												1
41	6029010002	EV.ESTATICO V4T4R700A10S PINT	1				1			1				
41	6029010004	EV.ESTATICO V4T3R1200A10PINT.		1				1			1		1	
41	6029010006	EV.ESTATICO V4T3R1700A10PINT.			1							1		1
41	6029010008	EV.ESTATICO V4T3R220A10SPINT.				1			1					
42	M109050419	BANDEJA DE GOTEO 150	1				1							
42	M109050125	BANDEJA GOTEO 200		1				1						
42	M109050126	BANDEJA GOTEO 250			1									
42	M109050420	BANDEJA DE GOTEO 300				1			1					
42	M109050421	BANDEJA DE GOTEO CENTRAL 150								1				
42	M109050422	BANDEJA DE GOTEO CENTRAL 200									1		1	
42	M109050423	BANDEJA DE GOTEO CENTRAL 250										1		1
43	6003010034	DESAGÜE SAN MIGUEL+TUERCA	1	1	1	1	1	1	1	1	1	1	1	1
44	6003010051	JUNTA GOMA DESAGUE 1/2	1	1	1	1	1	1	1	1	1	1	1	1
50	6033050014	GUIA PASTELERA EN L 649mm	8	12	16	20	8	12	20					
50	6033050013	GUIA PAST.CENTRAL EN L 711mm								8	12	16	12	16
51	6027010005	PARRILLA PASTEL.600X400 EPOXI	2	3	4	5	2	3	5	2	3	4	2	4
54	M109050591	CREM.RESP.IZD.ESTAT.MPP	2	3	4	5	2	3	5					
55	M109050592	CREM.RES.DCH.ESTAT.MPP	2	3	4	5	2	3	5					
56	M109050747	CREM. MARC. MAGNETICO MSP-MFP	4	6	8	10	4	6	10	8	12	16	12	16
60	6003010181	REJ.RESP.GRUPO 387X280POLICARB	1	1	1	1								
61	6021390006	MANG 3X1X2500 BL. SCHUKO 3T	1	1	1	1	1	1	1	1	1	1	1	1
62	M109050425	PROTECT SONDA MF GRAVEDAD	1	1	1	1	1	1	1	1	1	1	1	1
70	6021010037	CONDEN.ARRANQUE FR-117U5015 80 mF	1	1						1	1			
70	6021010158	CONDENSADOR COMP. NEK 6210Z			1	1						1		
71	6021010045	RELE ARRANQ COMPR.FR-7.5G 6001	1							1				
71	6021010025	RELE ARRANQUE COMPRESOR FR-8,5G 2		1							1			
71	6021010156	RELE ARRAN. COMP. NEK 6210Z			1	1						1		
90	M169010096	PUE MSP/MSN FAG.AP.DCHA								2	3	4	3	4
91	6033010130	SOP.BISAG.INF.DCHA.								2	3	4	3	4

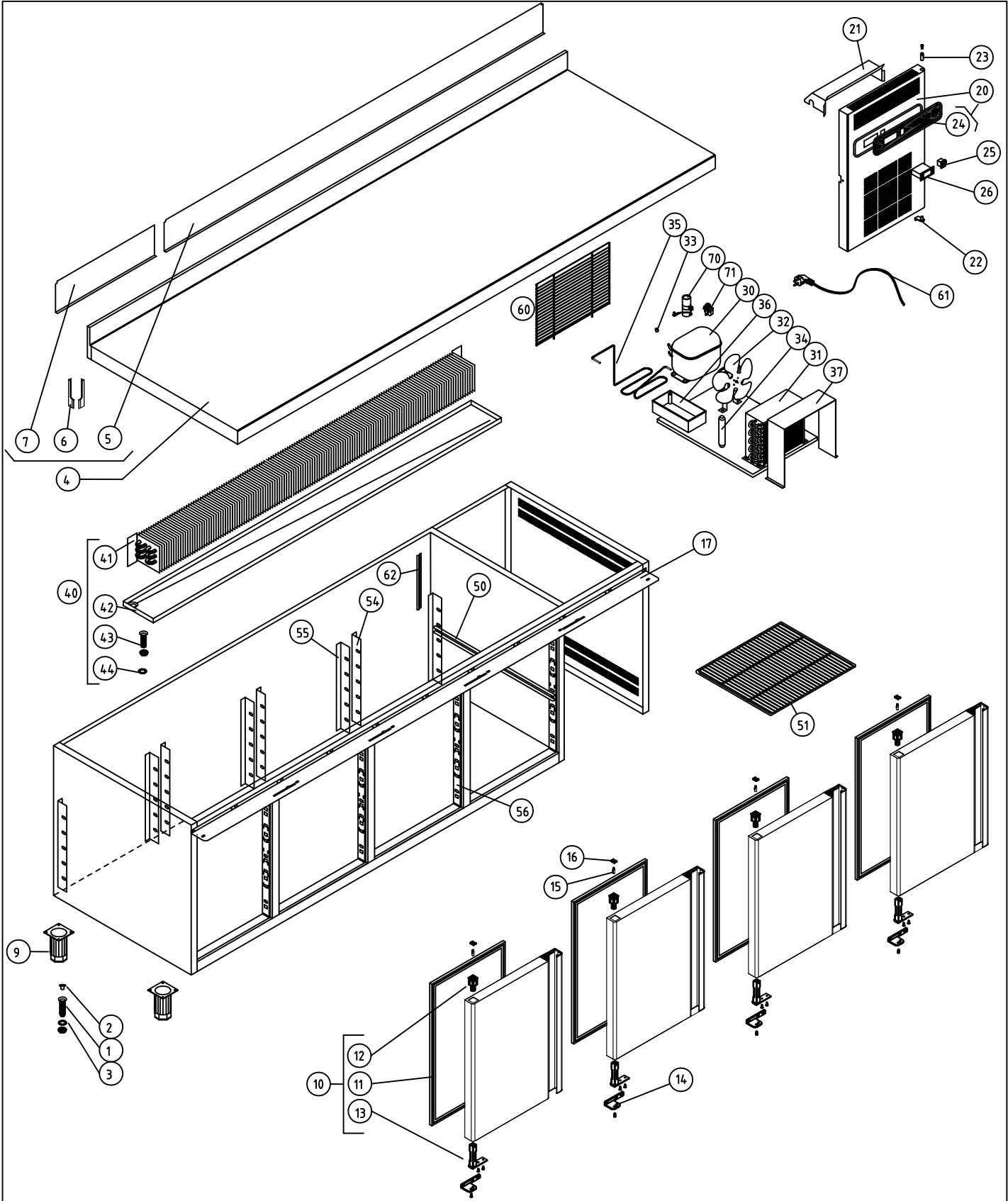

COTAS SIN TOLERANCIA DIN 7168-f					Material: MATERIAL ESPESOR					COD. PIEZA: 14.8412000000					
Acabado: ACABADO					SUSTITUYE A:					SUSTITUIDO POR:					
ANGULAR	GRADO TOLERANCIA	FINO	MEDIO	GRUESO	COMUN A	MODELO	Ud.	MODELO	Ud.	MODELO	Ud.	MODELO	Ud.	MODELO	
	HASTA 10 mm		±1°	±1° 30'		MPP-202	1								
	MAS DE 10 A 50 mm		±30'	±50'											
	MAS DE 50 A 120 mm		±20'	±25'											
LINEAL	MAS DE 120 A 400 mm		±10'	±15'											
	MAS DE 400 mm		±5'	±10'											
	GRADO TOLERANCIA	FINO	MEDIO	GRUESO	A4	Nombre			Fecha						
	HASTA 3 mm	±0,05	±0,10	±0,15	Dibujado	A.J.GONZALEZ			Dic-2010						
	MAS DE 3 A 6 mm	±0,05	±0,10	±0,20	Modificado										
MAS DE 6 A 30 mm	±0,10	±0,20	±0,50	Escala	RECAMBIOS MPP-202									Código máquina:	
MAS DE 30 A 120 mm	±0,15	±0,30	±0,80	1:22										CODIGO	
MAS DE 120 A 400 mm	±0,20	±0,50	±1,20												
MAS DE 400 A 1000 mm	±0,30	±0,80	±2,00												
MAS DE 1000 A 2000 mm	±0,50	±1,20	±3,00												



M1 MESAS SNACK				COD. 14841300000									
COTAS SIN TOLERANCIA DIN 7168-f				Material:									
ANGULAR	GRADO TOLERANCIA	FINO	MEDIO	GRUESO	Acabado:								
	HASTA 10 mm		±1°	±1° 30'	SUSTITUYE A:								
	MAS DE 10 A 50 mm		±30'	±50'	SUSTITUIDO POR:								
	MAS DE 50 A 120 mm		±20'	±25'									
	MAS DE 120 A 400 mm		±10'	±15'									
MAS DE 400 mm		±5'	±10'										
LINEAL	GRADO TOLERANCIA	FINO	MEDIO	GRUESO	COMUN A								
	HASTA 3 mm		±0,05	±0,10	±0,15	MODELO	Ud.	MODELO	Ud.	MODELO	Ud.	MODELO	Ud.
	MAS DE 3 A 6 mm		±0,05	±0,10	±0,20	MPP-255	1						
	MAS DE 6 A 30 mm		±0,10	±0,20	±0,50								
	MAS DE 30 A 120 mm		±0,15	±0,30	±0,80								
MAS DE 120 A 400 mm		±0,20	±0,50	±1,20									
MAS DE 400 A 1000 mm		±0,30	±0,80	±2,00									
MAS DE 1000 A 2000 mm		±0,50	±1,20	±3,00									
A4		Nombre		Fecha		 F A G O F R I							
Dibujado		A.J.GONZALEZ		Dic-2010									
Modificado													
Escala		1:25		RECAMBIOS MPP-255						Código máquina:			

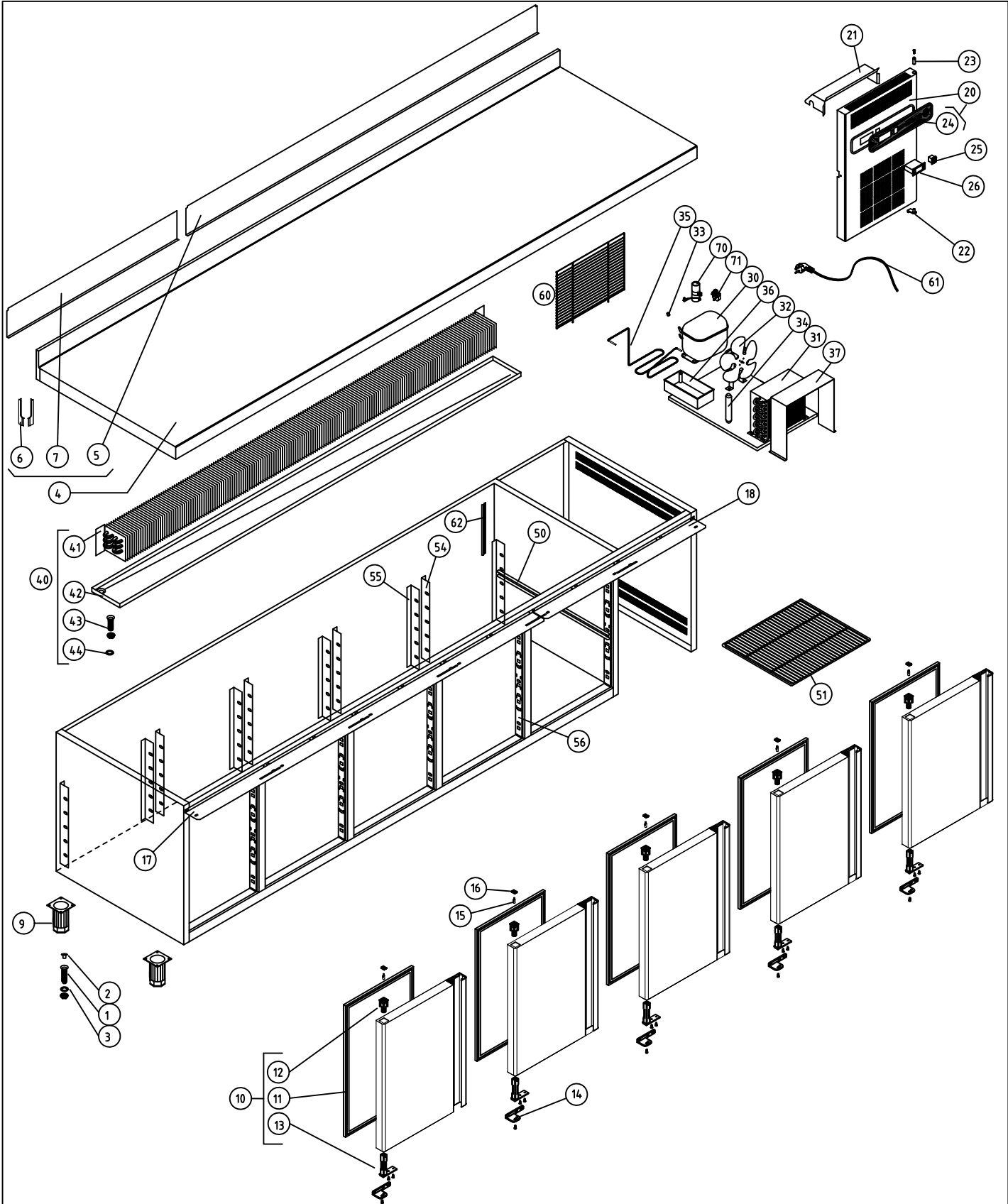

COTAS SIN TOLERANCIA DIN 7168-f				Material:				COD. 148414000000					
ANGULAR	GRADO TOLERANCIA	FINO	MEDIO	GRUESO	Acabado:				SUSTITUYE A:				
	HASTA 10 mm		±1°	±1° 30'	SUSTITUIDO POR:								
	MAS DE 10 A 50 mm		±30'	±50'	MODELO	Ud.	MODELO	Ud.	MODELO	Ud.	MODELO	Ud.	MODELO
	MAS DE 50 A 120 mm		±20'	±25'	MPP-307	1							
	MAS DE 120 A 400 mm		±10'	±15'									
MAS DE 400 mm		±5'	±10'										
LINEAL	GRADO TOLERANCIA	FINO	MEDIO	GRUESO	A4		Nombre		Fecha				
	HASTA 3 mm	±0,05	±0,10	±0,15	Dibujado		A.J.GONZALEZ		Dic-2010				
	MAS DE 3 A 6 mm	±0,05	±0,10	±0,20	Modificado								
	MAS DE 6 A 30 mm	±0,10	±0,20	±0,50	Escala		1:27		RECAMBIOS MPP-307		Código máquina:		
	MAS DE 30 A 120 mm	±0,15	±0,30	±0,80									
MAS DE 120 A 400 mm	±0,20	±0,50	±1,20										
MAS DE 400 A 1000 mm	±0,30	±0,80	±2,00										
MAS DE 1000 A 2000 mm	±0,50	±1,20	±3,00										

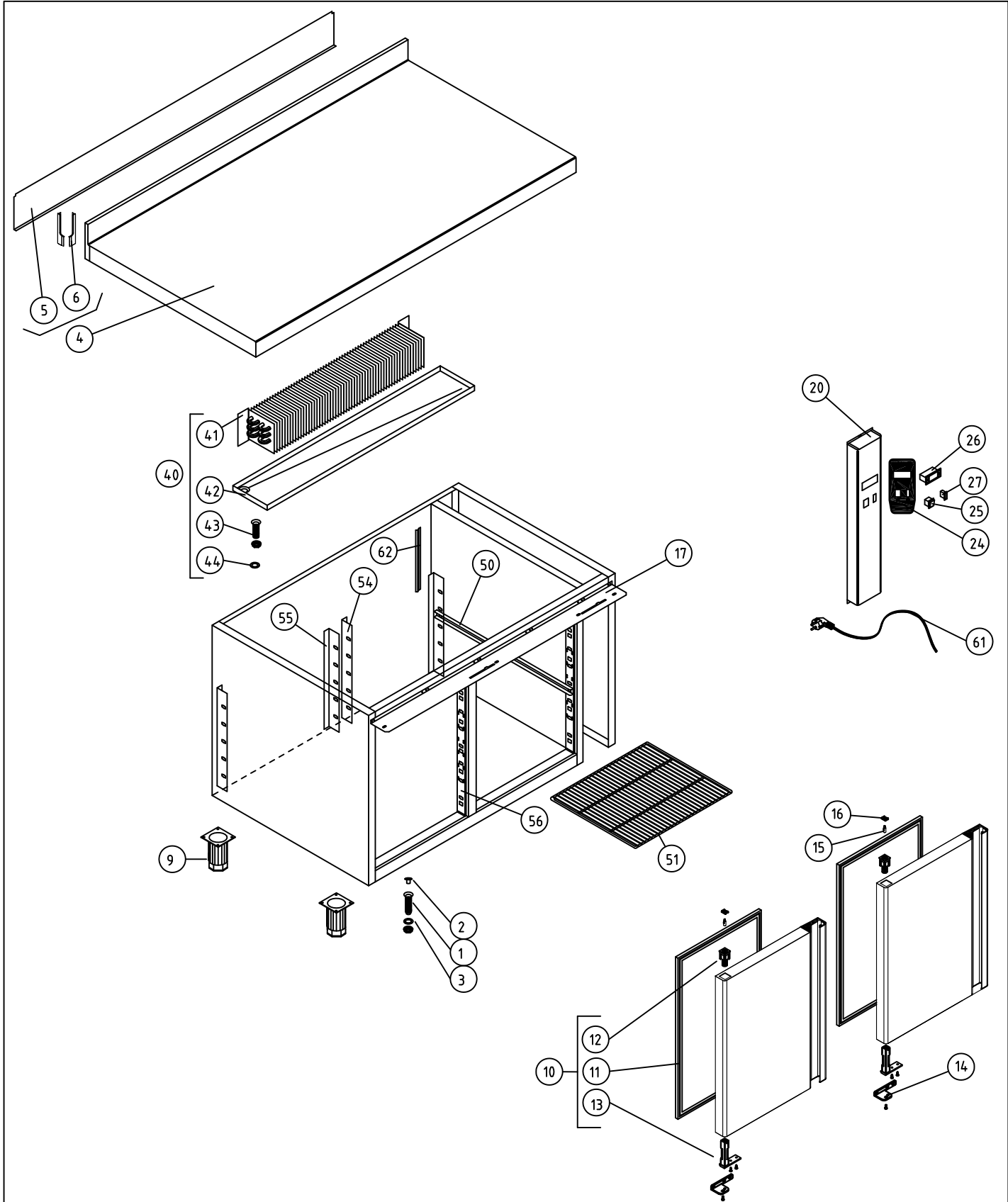

COTAS SIN TOLERANCIA DIN 7168-f										Material: MATERIAL ESPESOR		COD. PIEZA: 148411001000			
Acabado: ACABADO										SUSTITUYE A:		SUSTITUIDO POR:			
ANGULAR	GRADO TOLERANCIA	FINO	MEDIO	GRUESO	COMUN A	MODELO	Ud.	MODELO	Ud.	MODELO	Ud.	MODELO	Ud.	MODELO	
	HASTA 10 mm		±1°	±1° 30'		MPP-117-R	1								
	MAS DE 10 A 50 mm		±30'	±50'											
	MAS DE 50 A 120 mm		±20'	±25'											
LINEAL	MAS DE 120 A 400 mm		±10'	±15'	A4	Nombre		Fecha				Código máquina: CODIGO			
	MAS DE 400 mm		±5'	±10'		Dibujado A.J.GONZALEZ		Dic-2010							
	GRADO TOLERANCIA	FINO	MEDIO	GRUESO		Modificado				Escala 1:22		RECAMBIOS MPP-117-R			
	HASTA 3 mm	±0,05	±0,10	±0,15											
	MAS DE 3 A 6 mm	±0,05	±0,10	±0,20											
MAS DE 6 A 30 mm	±0,10	±0,20	±0,50												
MAS DE 30 A 120 mm	±0,15	±0,30	±0,80												
MAS DE 120 A 400 mm	±0,20	±0,50	±1,20												
MAS DE 400 A 1000 mm	±0,30	±0,80	±2,00												
MAS DE 1000 A 2000 mm	±0,50	±1,20	±3,00												

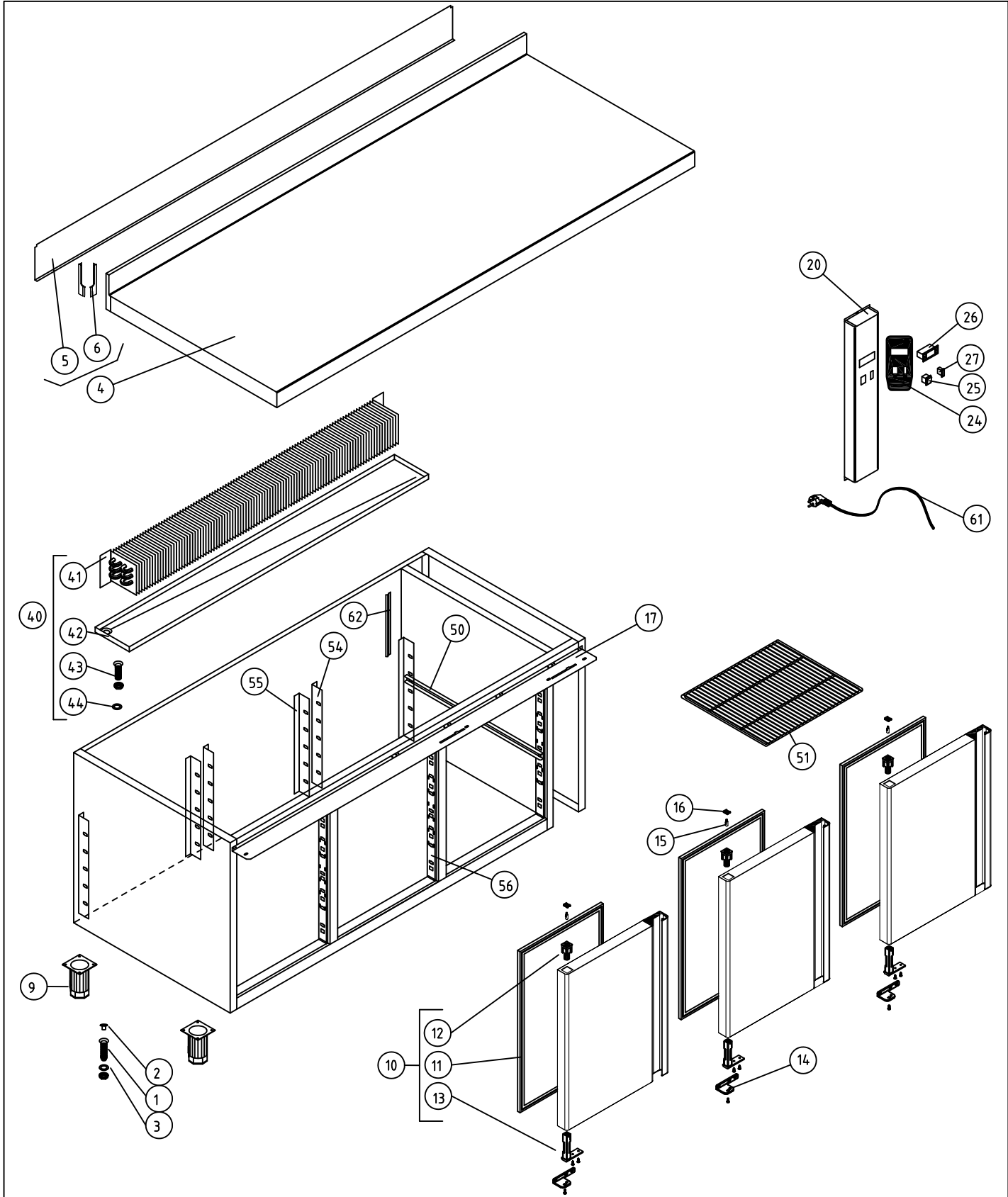

COTAS SIN TOLERANCIA DIN 7168-f						Material: MATERIAL ESPESOR				COD. PIEZA: 148412001000					
GRADO TOLERANCIA						Acabado: ACABADO				SUSTITUYE A:					
ANGULAR	HASTA 10 mm	FINO	MEDIO	GRUESO		SUSTITUIDO POR:									
	MAS DE 10 A 50 mm		±1°	±1° 30'											
	MAS DE 50 A 120 mm		±30'	±50'											
	MAS DE 120 A 400 mm		±20'	±25'											
	MAS DE 400 mm		±10'	±15'											
COMUN A						MODELO	Ud.	MODELO	Ud.	MODELO	Ud.	MODELO	Ud.	MODELO	
						MPP-169-R	1								
LINEAL						GRADO TOLERANCIA		FINO		MEDIO		GRUESO			
						HASTA 3 mm		±0,05		±0,10		±0,15			
						MAS DE 3 A 6 mm		±0,05		±0,10		±0,20			
						MAS DE 6 A 30 mm		±0,10		±0,20		±0,50			
						MAS DE 30 A 120 mm		±0,15		±0,30		±0,80			
						MAS DE 120 A 400 mm		±0,20		±0,50		±1,20			
						MAS DE 400 A 1000 mm		±0,30		±0,80		±2,00			
						MAS DE 1000 A 2000 mm		±0,50		±1,20		±3,00			
A4		Nombre		Fecha		FAGOR		F A G O F R I		Código máquina:		CODIGO			
Dibujado		A.J.GONZALEZ		Dic-2010		RECAMBIOS MPP-169-R									
Modificado						Escala		1:22							

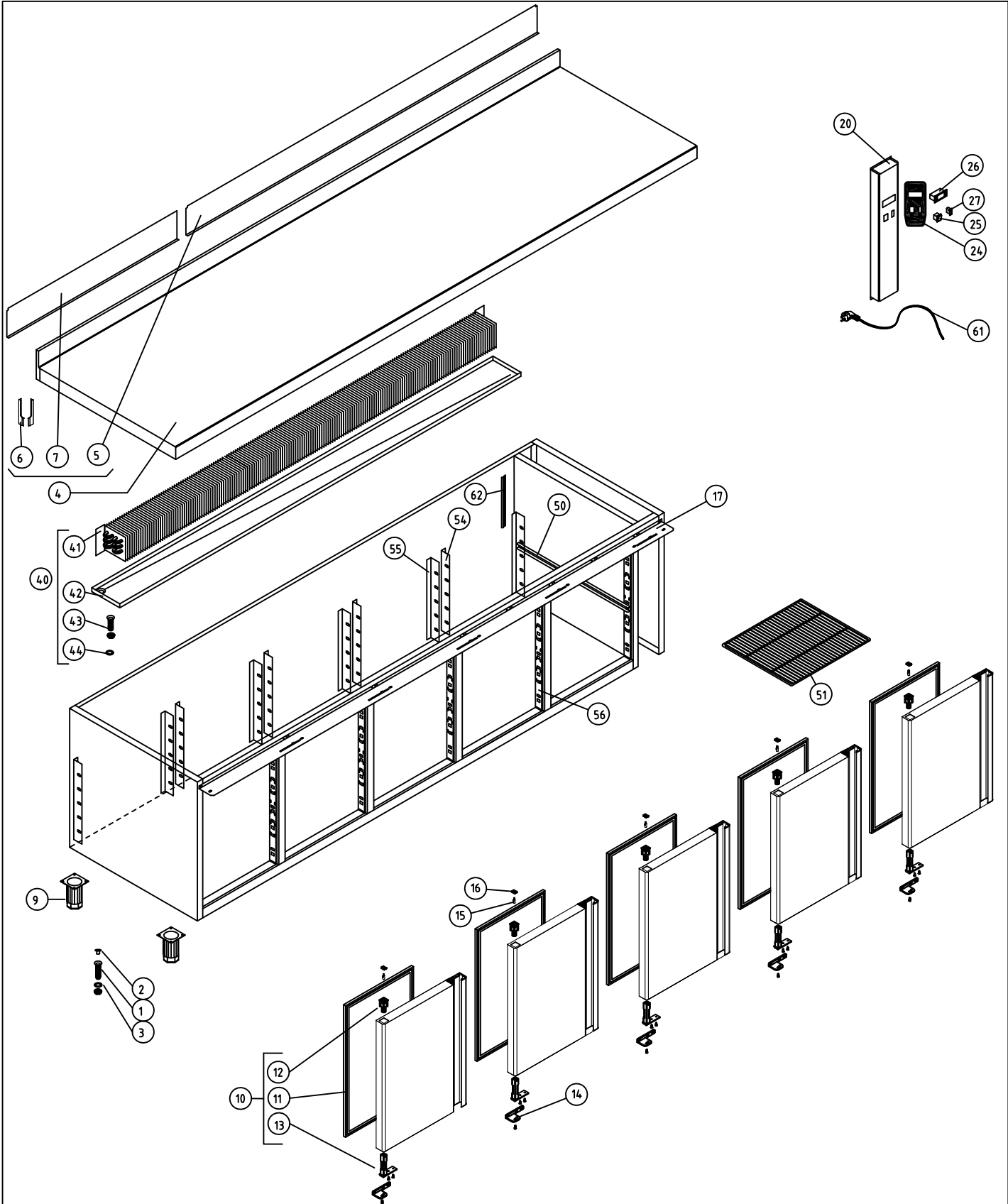

COTAS SIN TOLERANCIA DIN 7168-f					Material:					COD. 148414001000					
ANGULAR	GRADO TOLERANCIA	FINO	MEDIO	GRUESO	Acabado:					SUSTITUYE A:					
	HASTA 10 mm		±1°	±1° 30'	SUSTITUIDO POR:										
	MAS DE 10 A 50 mm		±30'	±50'											
	MAS DE 50 A 120 mm		±20'	±25'											
	MAS DE 120 A 400 mm		±10'	±15'											
MAS DE 400 mm		±5'	±10'												
LINEAL	GRADO TOLERANCIA	FINO	MEDIO	GRUESO	COMUN A										
	HASTA 3 mm		±0,05	±0,10	±0,15	MODELO	Ud.	MODELO	Ud.	MODELO	Ud.	MODELO	Ud.	MODELO	Ud.
	MAS DE 3 A 6 mm		±0,05	±0,10	±0,20	MPP-274-R	1								
	MAS DE 6 A 30 mm		±0,10	±0,20	±0,50										
	MAS DE 30 A 120 mm		±0,15	±0,30	±0,80										
MAS DE 120 A 400 mm		±0,20	±0,50	±1,20	A4					Nombre					
MAS DE 400 A 1000 mm		±0,30	±0,80	±2,00	Dibujado					A.J.GONZALEZ					
MAS DE 1000 A 2000 mm		±0,50	±1,20	±3,00	Modificado					Fecha					
					Escala					Dic-2010					
					1:27					FAGOR 					
RECAMBIOS MPP-274-R										Código máquina:					

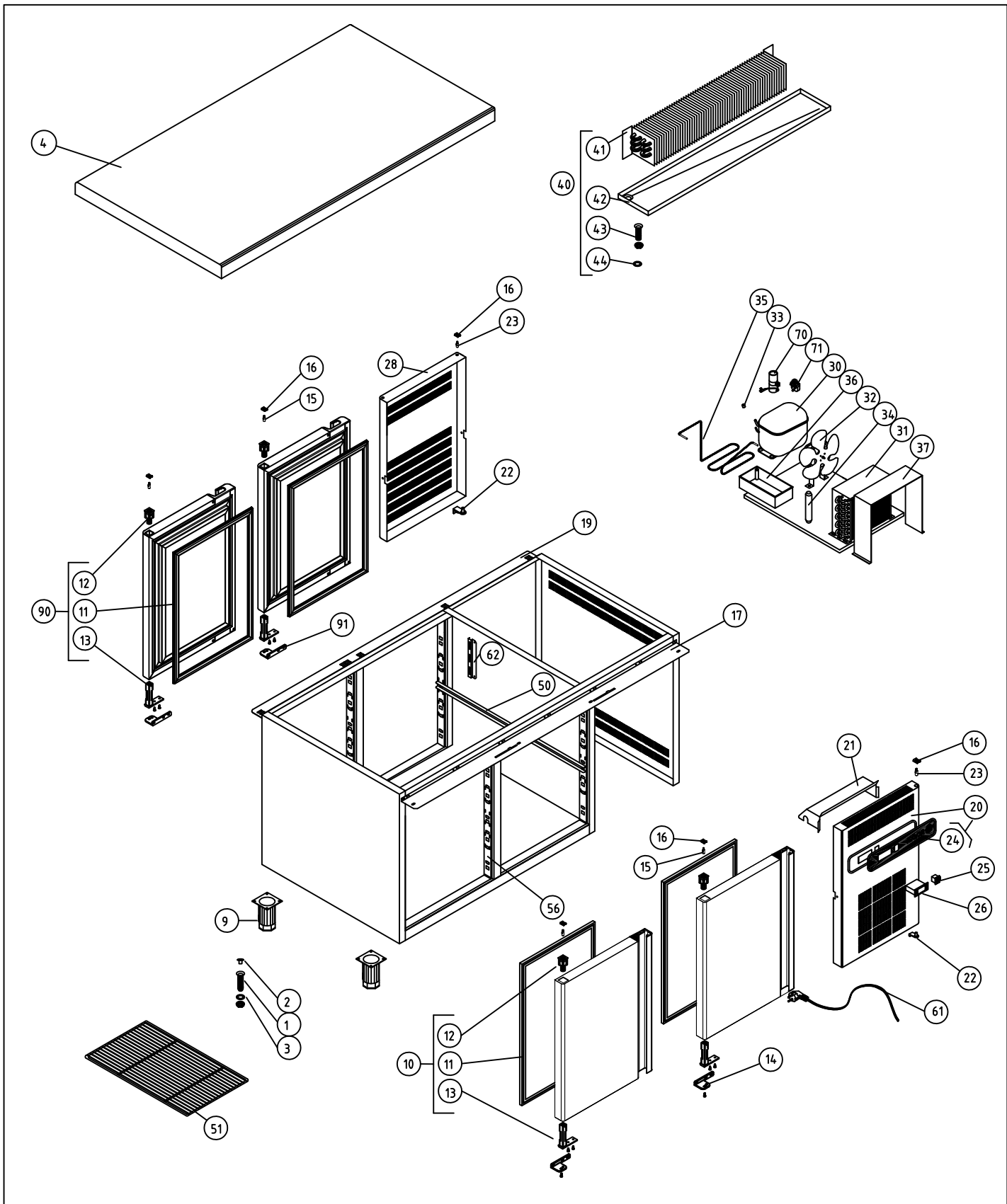

COTAS SIN TOLERANCIA DIN 7168-f						COD. PIEZA: 148411010000								
Material: MATERIAL ESPESOR						SUSTITUYE A:								
Acabado: ACABADO						SUSTITUIDO POR:								
ANGULAR	GRADO TOLERANCIA	FINO	MEDIO	GRUESO	COMUN A	MODELO	Ud.	MODELO	Ud.	MODELO	Ud.	MODELO	Ud.	
	HASTA 10 mm		±1°	±1° 30'		MPP-150-C	1							
	MAS DE 10 A 50 mm		±30'	±50'										
	MAS DE 50 A 120 mm		±20'	±25'										
LINEAL	MAS DE 120 A 400 mm		±10'	±15'										
	MAS DE 400 mm		±5'	±10'										
	GRADO TOLERANCIA	FINO	MEDIO	GRUESO	A4	Nombre	Fecha		 F A G O R I					
	HASTA 3 mm	±0,05	±0,10	±0,15	Dibujado	A.J.GONZALEZ	Dic-2010							
	MAS DE 3 A 6 mm	±0,05	±0,10	±0,20	Modificado									
	MAS DE 6 A 30 mm	±0,10	±0,20	±0,50	Escala	1:25		RECAMBIOS MPP-150-C						
MAS DE 30 A 120 mm	±0,15	±0,30	±0,80			Código máquina:								
MAS DE 120 A 400 mm	±0,20	±0,50	±1,20			CODIGO								
MAS DE 400 A 1000 mm	±0,30	±0,80	±2,00											
MAS DE 1000 A 2000 mm	±0,50	±1,20	±3,00											

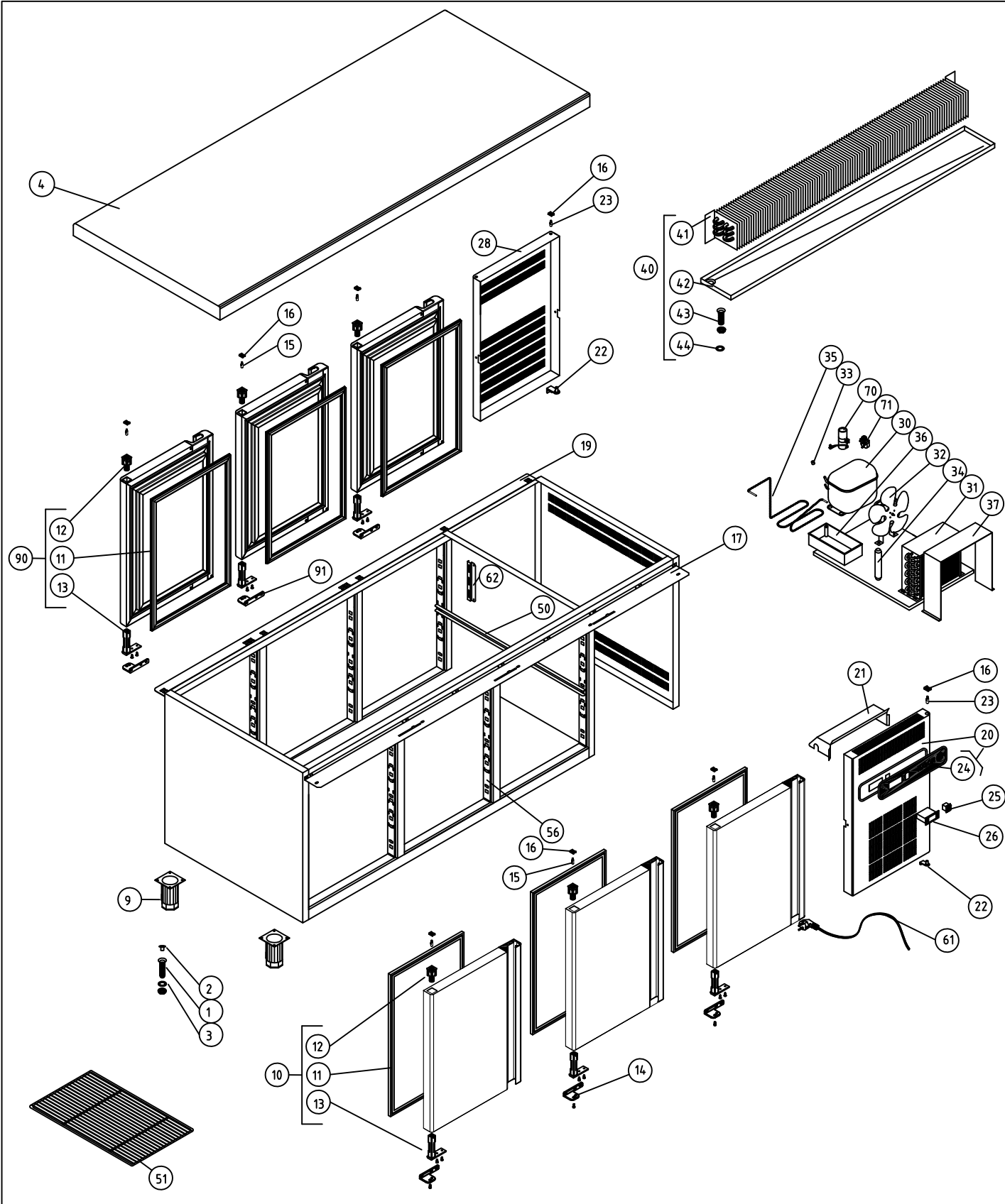

COD. PIEZA: 148412010000

COTAS SIN TOLERANCIA DIN 7168-f				
	GRADO TOLERANCIA	FINO	MEDIO	GRUESO
ANGULAR	HASTA 10 mm		±1°	±1° 30'
	MAS DE 10 A 50 mm		±30'	±50'
	MAS DE 50 A 120 mm		±20'	±25'
	MAS DE 120 A 400 mm		±10'	±15'
	MAS DE 400 mm		±5'	±10'
LINEAL	GRADO TOLERANCIA	FINO	MEDIO	GRUESO
	HASTA 3 mm	±0,05	±0,10	±0,15
	MAS DE 3 A 6 mm	±0,05	±0,10	±0,20
	MAS DE 6 A 30 mm	±0,10	±0,20	±0,50
	MAS DE 30 A 120 mm	±0,15	±0,30	±0,80
	MAS DE 120 A 400 mm	±0,20	±0,50	±1,20
MAS DE 400 A 1000 mm	±0,30	±0,80	±2,00	
MAS DE 1000 A 2000 mm	±0,50	±1,20	±3,00	

Material: MATERIAL ESPESOR		Acabado: ACABADO							
COMUN A	MODELO	Ud.	MODELO	Ud.	MODELO	Ud.	MODELO	Ud.	MODELO
	MPP-202-C	1							
A4	Nombre	Fecha							
Dibujado	A.J.GONZALEZ	Dic-2010							
Modificado									
Escala	1:25			RECAMBIOS MPP-202-C					

SUSTITUYE A:	
SUSTITUIDO POR:	
Código máquina:	
CODIGO	

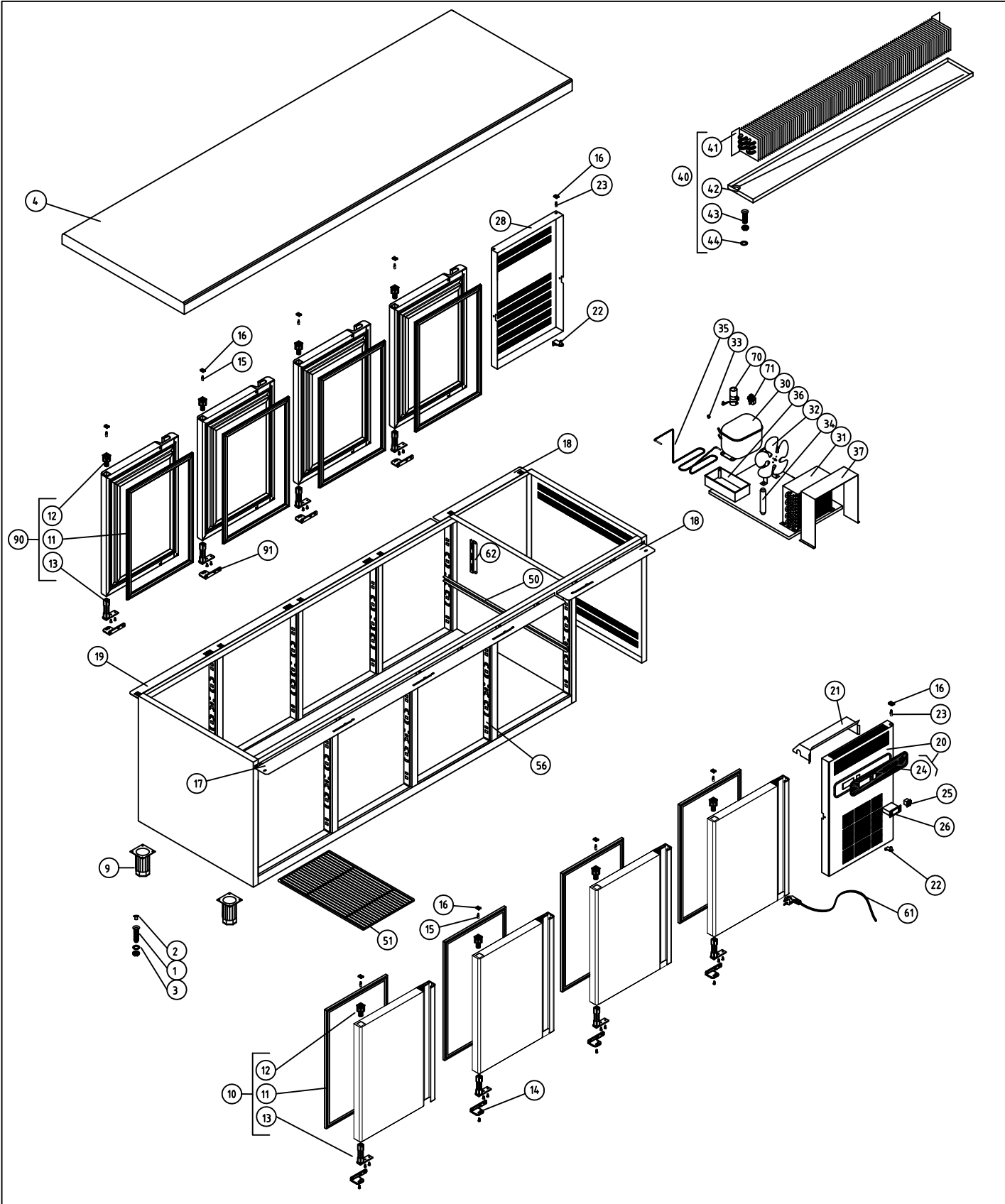

COTAS SIN TOLERANCIA DIN 7168-f				Material: .				COD. PIEZA: 148413010000			
GRADO TOLERANCIA				Acabado: .				SUSTITUYE A: .			
ANGULAR	HASTA 10 mm	FINO	MEDIO	GRUESO	SUSTITUIDO POR:						
	MAS DE 10 A 50 mm		±1°	±1° 30'	MODELO	Ud.	MODELO	Ud.	MODELO	Ud.	MODELO
	MAS DE 50 A 120 mm		±30'	±50'	MPP-255-C	1					
	MAS DE 120 A 400 mm		±20'	±25'							
	MAS DE 400 mm		±10'	±15'							
			±5'	±10'							
LINEAL	GRADO TOLERANCIA	FINO	MEDIO	GRUESO	A4		Nombre		Fecha		
	HASTA 3 mm	±0,05	±0,10	±0,15	Dibujado		A.J.GONZALEZ		Dic-2010		
	MAS DE 3 A 6 mm	±0,05	±0,10	±0,20	Modificado						
	MAS DE 6 A 30 mm	±0,10	±0,20	±0,50	Escala		1:30		RECAMBIOS MPP-255-C		
	MAS DE 30 A 120 mm	±0,15	±0,30	±0,80					Código máquina:		
MAS DE 120 A 400 mm	±0,20	±0,50	±1,20								
MAS DE 400 A 1000 mm	±0,30	±0,80	±2,00								
MAS DE 1000 A 2000 mm	±0,50	±1,20	±3,00								

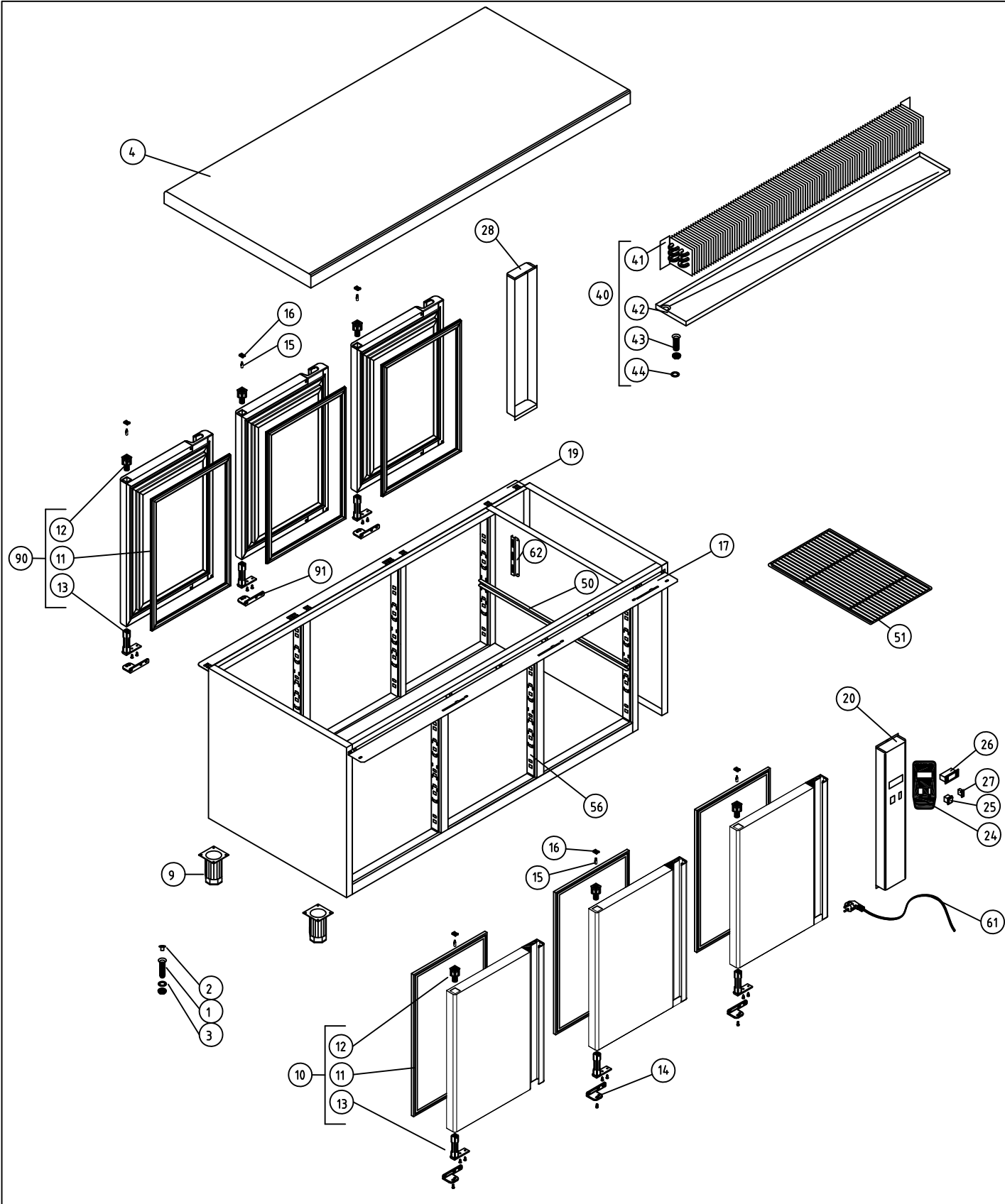

COTAS SIN TOLERANCIA DIN 7168-f				Material: .				COD. PIEZA: 148412011000					
GRADO TOLERANCIA				Acabado: .				SUSTITUYE A: .					
ANGULAR	HASTA 10 mm	FINO	MEDIO	GRUESO					SUSTITUIDO POR: .				
	MAS DE 10 A 50 mm		±1°	±1° 30'	MODELO	Ud.	MODELO	Ud.	MODELO	Ud.	MODELO	Ud.	
	MAS DE 50 A 120 mm		±30'	±50'	MPP-169-R/C	1							
	MAS DE 120 A 400 mm		±20'	±25'									
	MAS DE 400 mm		±10'	±15'									
			±5'	±10'									
LINEAL	GRADO TOLERANCIA	FINO	MEDIO	GRUESO									
	HASTA 3 mm		±0,05	±0,10	±0,15	A4		Nombre		Fecha			
	MAS DE 3 A 6 mm		±0,05	±0,10	±0,20	Dibujado		A.J.GONZALEZ		Dic-2010			
	MAS DE 6 A 30 mm		±0,10	±0,20	±0,50	Modificado							
	MAS DE 30 A 120 mm		±0,15	±0,30	±0,80	Escala		1:25		RECAMBIOS MPP-169-R/C			
MAS DE 120 A 400 mm		±0,20	±0,50	±1,20					Código máquina:				
MAS DE 400 A 1000 mm		±0,30	±0,80	±2,00					CODIGO				
MAS DE 1000 A 2000 mm		±0,50	±1,20	±3,00									

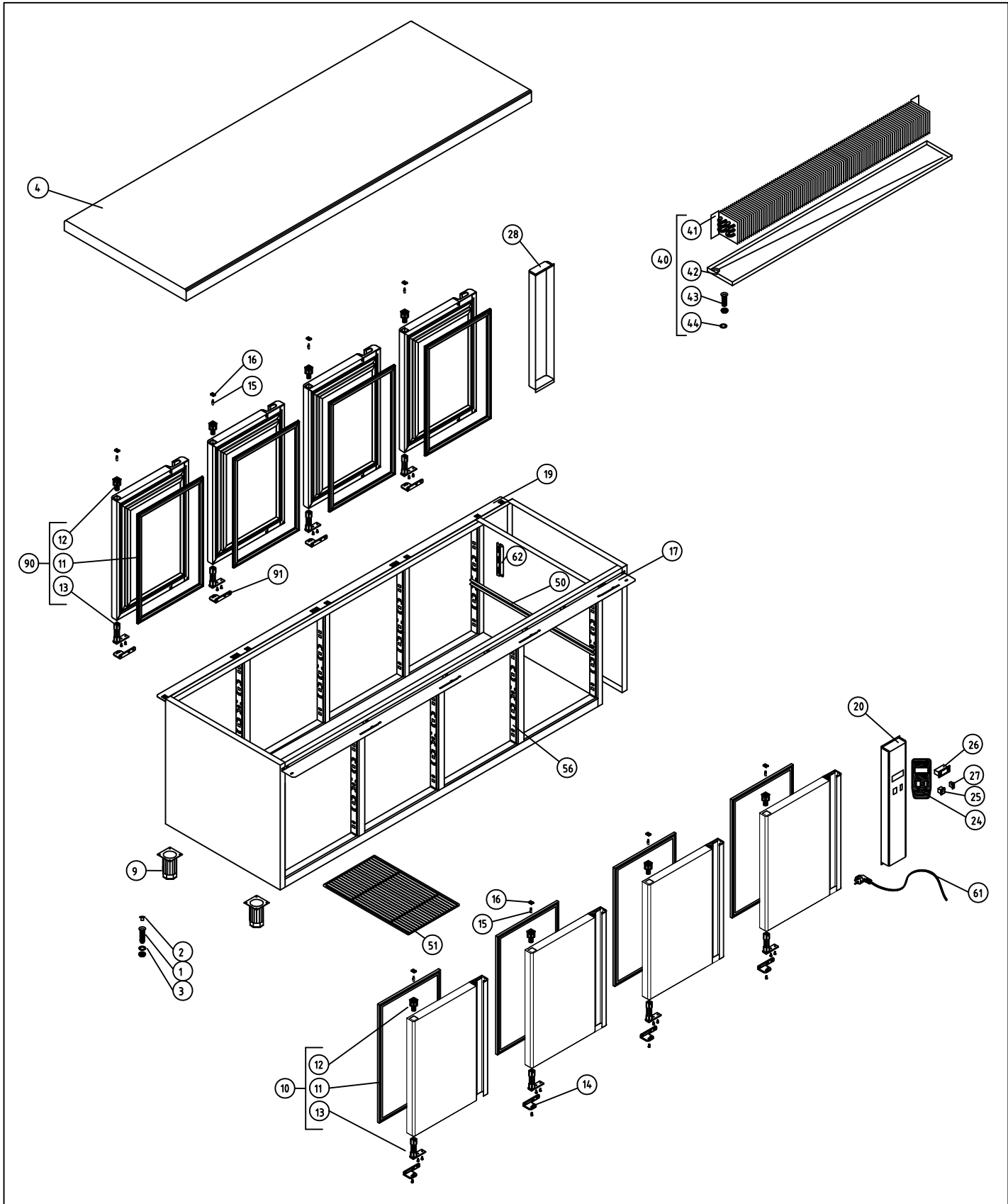

COTAS SIN TOLERANCIA DIN 7168-f				Material: .				COD. PIEZA: 148413011000					
ANGULAR	GRADO TOLERANCIA	FINO	MEDIO	GRUESO	Acabado: .				SUSTITUYE A:				
	HASTA 10 mm		±1°	±1° 30'	SUSTITUIDO POR:								
	MAS DE 10 A 50 mm		±30'	±50'	MODELO	Ud.	MODELO	Ud.	MODELO	Ud.	MODELO	Ud.	MODELO
	MAS DE 50 A 120 mm		±20'	±25'	MPP-222-R/C	1							
LINEAL	MAS DE 120 A 400 mm		±10'	±15'	COMUN A								
	MAS DE 400 mm		±5'	±10'									
	GRADO TOLERANCIA	FINO	MEDIO	GRUESO	A4	Nombre		Fecha					
	HASTA 3 mm	±0,05	±0,10	±0,15	Dibujado	A.J.GONZALEZ		Dic-2010					
	MAS DE 3 A 6 mm	±0,05	±0,10	±0,20	Modificado					Código máquina: CODIGO			
MAS DE 6 A 30 mm	±0,10	±0,20	±0,50	Escala					RECAMBIOS MPP-222-R/C				
MAS DE 30 A 120 mm	±0,15	±0,30	±0,80	1:30									
MAS DE 120 A 400 mm	±0,20	±0,50	±1,20										
MAS DE 400 A 1000 mm	±0,30	±0,80	±2,00										
MAS DE 1000 A 2000 mm	±0,50	±1,20	±3,00										