

DESPIECES

MESAS MMZ



Rev.: Feb-2011

**RECAMBIOS
MESAS MMZ
FEB-2011**



MODELOS

MMZ-150	MMZ-202	MMZ-180-7	MMZ-225-7
---------	---------	-----------	-----------

Nº	CÓDIGO	DESCRIPCIÓN	MMZ-150	MMZ-202	MMZ-180-7	MMZ-225-7
1	6003010326	DESAG COMPL 3/4 GRIS+TUERCA	1	1	1	1
2	6003010262	TAPON DESAGÜE DE 3/4 CIEGO	1	1	1	1
3	6003010327	JUNTA GOMA DESAGÜE 3/4	1	1	1	1
4	6031010085	ENC.MARM.PETO MMZ-150	1			
4	6031010079	ENCIM.MARM.PETO MMZ-202		1		
4	6031010092	ENC.MAR.PETO 1790X700X30 MFP-180			1	
4	6031010093	ENC.MAR.PETO 2240X700X30 MFP-225				1
9	6007050017	PATA REGULAB ARM GASTRO	4	6	6	8
10	M169010088	PUE MSP/MSN AP.IZDA	2	2		
10	M169010093	PUE MFP/MFN FAGOR			2	3
11	6045010115	BURLETE 465X585 UR-260 MSP	2	2		
11	6045010119	BURLETE MFP 399X585 MFP			2	3
12	6003010136	CAJA ALOJAMIENTO MUELLE GRIS	2	2	2	3
13	6033010100	BIS.TRS1D DOBL MUELLE DV-2608	2	2	2	3
14	6033010129	SOP.BISAG.INF.IZD.	2	2	2	3
15	6033090104	EJE ROSCA EXT.30X10INOX MESAS	2	2	2	3
16	6025130045	TUERC.RAPIDA TRT M6-2	3	3	3	4
17	M109050260	SOPOR.SUP.PUERTAS MSP-150	1			
17	M109050266	SOP.SUP.PUER.MSP20-25-30		1		
17	M109050242	SOP.SUP.PUERTAS MFP-180			1	
17	M109050555	SOP.SUP.PUERT. MFP-225				1
20	M177010065	CHAP.CUAD.MANDOS	1	1	1	1
21	M109050532	PROTECC.INST.ELECT.FAGOR	1	1	1	1
22	6033090090	SOPORTE ZAMAK GIRO REJILLA	1	1	1	1
23	6033090104	EJE ROSCA EXT.30X10INOX MESAS	1	1	1	1
24	6023010408	PEG.CUAD.FAGOR REFR.347,5X60	1	1	1	1
25	6021130001	INT.BIP.AMB.O/I CONTAC.REFORZ.	1	1	1	1
26	6021350018	TERMOS REFRI CAREL PYCO1RN515	1	1	1	1
30	6021010004	COMPR.FR-7,5-G R134A	1	1	1	
30	6021010007	COMPR.FR-8.5-G R134A				1
31	6029020002	CONDENSADOR 9x2	1	1	1	1
32	6021050002	VENTILADOR 10W PATA PALA 220V	1	1	1	1
33	6021310003	VALVULA OBUS COMPLETA RF.HB-1S	1	1	1	1
34	6047010003	FILTRO DESHIDRAT.40GR 1/4X1/4	1	1	1	1
35	M107010037	SERP.EV.AUTOM.1/4 PINT.150,200	1	1	1	1
36	6003010023	BANDEJA EVAPORACION AUTOMÁTICA	1	1	1	1
37	M109250127	OMEGA COND.9X2-REJ.MESAS-ARMAR	1	1	1	1
40	M171010108	UD.EV.MSP150,200,135,180 COMP.	1	1	1	1
41	6029010151	BAT.5T4R300A4S PINT.MESAS	1	1	1	1
42	M109250148	SUJ.VENTIL.MSP-150,200 COMPACT	1	1	1	1
43	6027130004	REJILLA VENT.D.246 PINTADA	1	1	1	1
44	6021050066	VENTIL.EVAPOR.5W S/ARO S/PATAS	1	1	1	1
45	M109250151	SOP.EVAP.MESAS EVAP.COMPACTO	1	1	1	1

RECAMBIOS
MESAS MMZ
FEB-2011



MODELOS

Nº	CÓDIGO	DESCRIPCIÓN	MODELOS			
			MMZ-150	MMZ-202	MMZ-180-7	MMZ-225-7
46	M109250150	CUBRER.BAT.6T4R300A6S EVAP.COM	1	1	1	1
47	6003010184	CANALIZAD.AGUA 150 GRIS REFRIG	1	1	1	1
50	6033050014	GUIA PASTELERA EN L 649mm	8	8		
50	6033050015	GUIA SNAK.DT.CONG-MESA GN562mm			8	12
51	6027010005	PARRILLA PASTEL.600X400 EPOXI	2	2		
51	6027010003	PARRILLA GN1/1 530x325			2	3
52	M109050298	CREMALL.LATER.DCHA.MFP			1	1
53	M109050299	CREMALL.LAT.IZDA.MFP			1	1
54	M109050383	CREM.RESP.IZDA.T.FORZ.MPP	2	2		
54	M109050301	CREMALL.RESP.IZDA.MFP			1	2
55	M109050382	CREM.RESP.DCHA.T.FORZ.MPP	2	2		
55	M109050587	CREM.RESP.DCH.CONG MFN			1	1
56	M109050747	CREM. MARC. MAGNETICO MSP-MFP	4	4	4	6
57	M109050300	CREMALL.RESP.DCHA.MFP				1
60	6003010181	REJ.RESP.GRUPO 387X280POLICARB	1	1	1	1
61	6021390006	MANG 3X1X2500 BL. SCHUKO 3T	1	1	1	1
62	M109050033	PROT SONDA 175x49	1	1	1	1
63	M109010643	EMPELL.FRONTAL MSP-150 SE	1			
63	M109010644	EMPELL.FRONT.MSP-200 SE		1		
63	M109010853	EMPELL.FRONTAL MFP-180-SE			1	
63	M109010874	DECORAT.MFP-225 S.E.				1
70	6021010037	CONDEN.ARRANQUE FR-117U5015 80 mF	1	1	1	1
71	6021010045	RELE ARRANQ COMPR.FR-7.5G 6001	1	1	1	
71	6021010025	RELE ARRANQUE COMPRESOR FR-8,5G 2				1
80	M169130018	CAJON MMZ (COMPLETO)		7		
80	M169130048	CAJON NEUTRO PIZZAS (COMPLETO)			7	7
81	6033050003	GUIA CORREDERA 600MM ZINC(JUEGO)		7	7	7
82	6003010079	CUBETA POLIET.600x400x75 GRIS		7		
82	M109050681	FONDO PERF.MOD.CAJONERA			7	7

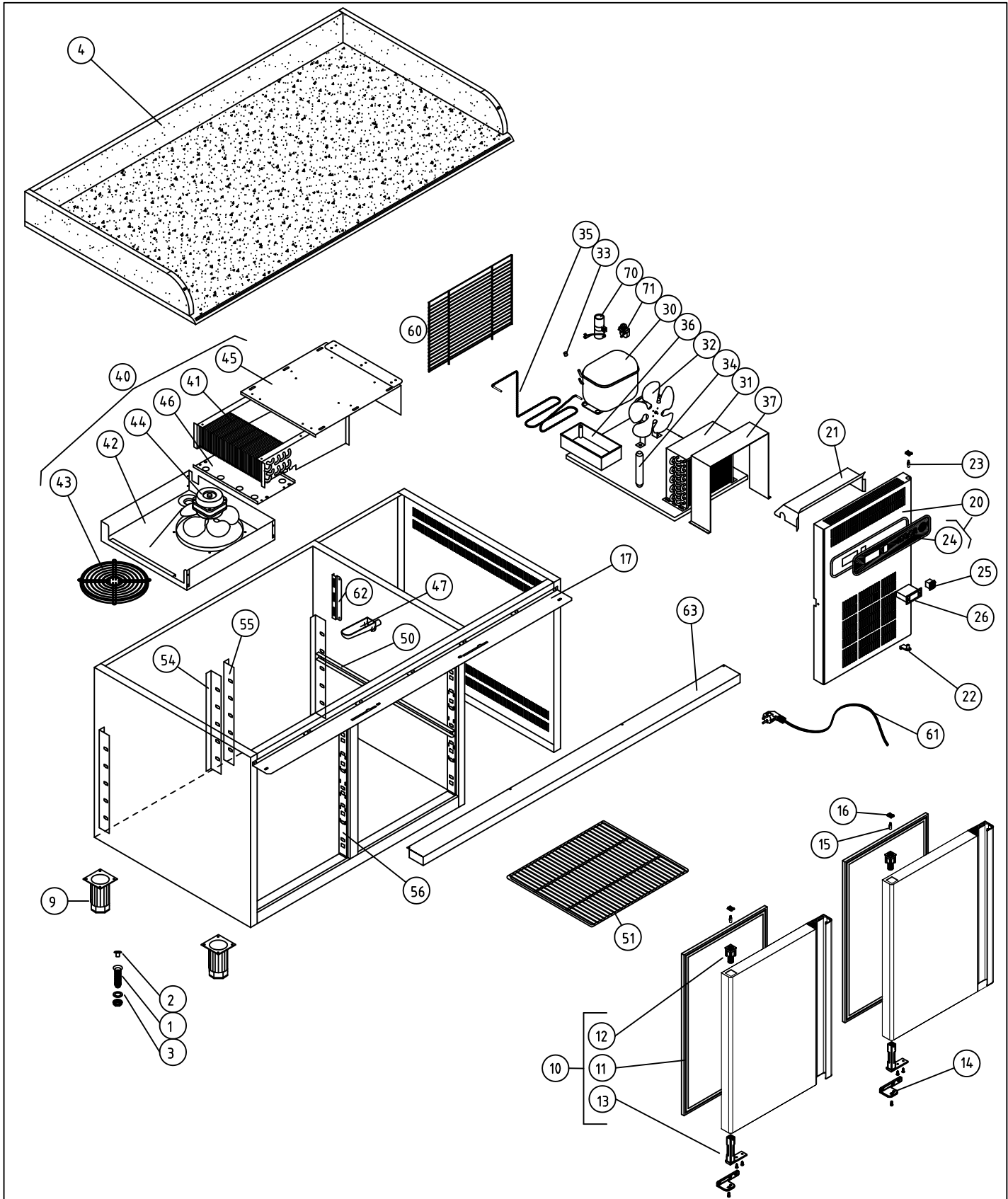

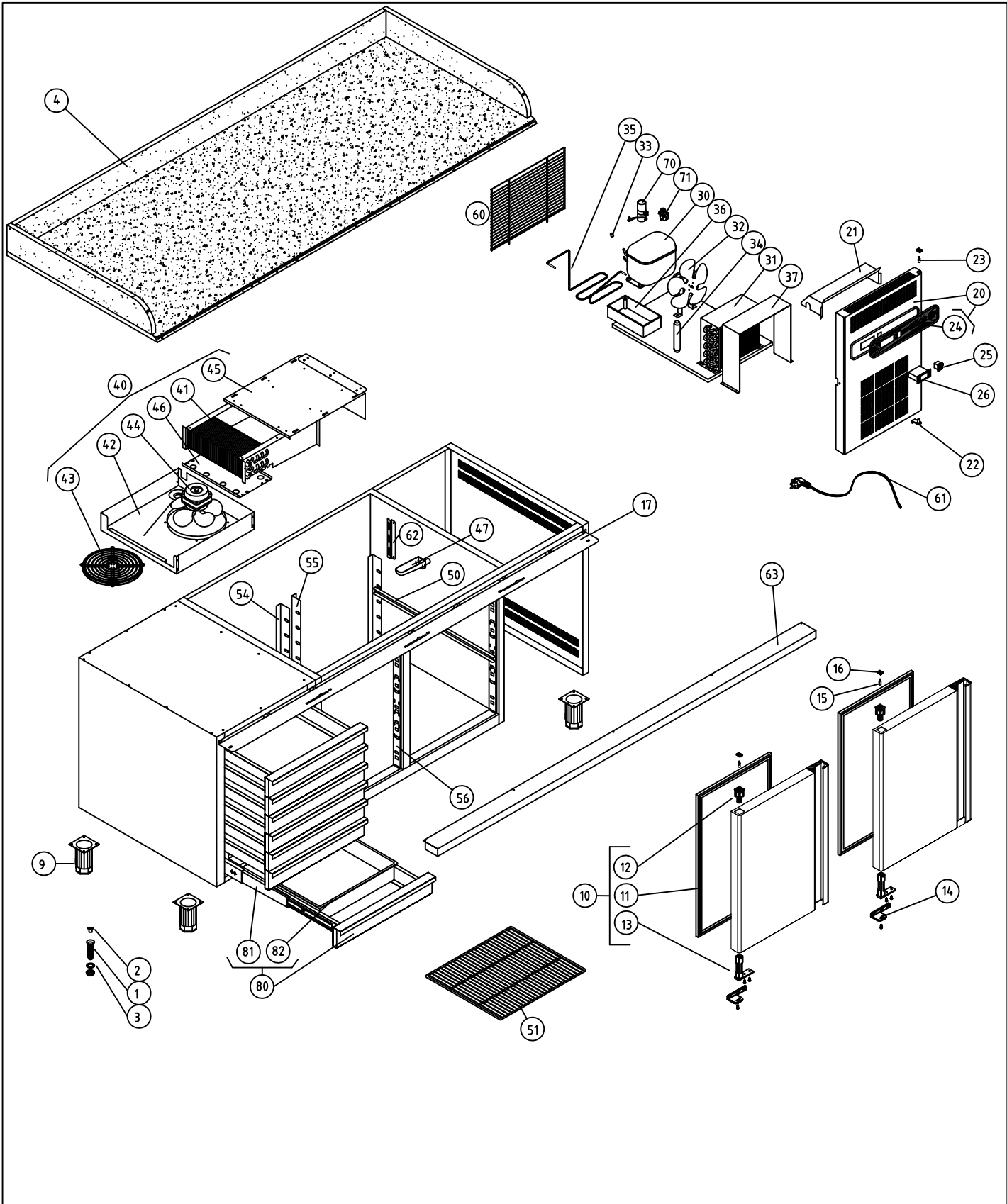

COTAS SIN TOLERANCIA DIN 7168-f						Material: .				COD. PIEZA: 148611000000			
ANGULAR	GRADO TOLERANCIA	FINO	MEDIO	GRUESO	COMUN A	Acabado: .				SUSTITUYE A:			
	HASTA 10 mm		±1°	±1° 30'		SUSTITUIDO POR:							
	MAS DE 10 A 50 mm		±30'	±50'		MODELO	Ud.	MODELO	Ud.	MODELO	Ud.	MODELO	Ud.
	MAS DE 50 A 120 mm		±20'	±25'		MMZ-150	1						
	MAS DE 120 A 400 mm		±10'	±15'									
MAS DE 400 mm		±5'	±10'										
LINEAL	GRADO TOLERANCIA	FINO	MEDIO	GRUESO	A4		Nombre		Fecha				
	HASTA 3 mm	±0,05	±0,10	±0,15	Dibujado		A.J.GONZALEZ		Feb-2011				
	MAS DE 3 A 6 mm	±0,05	±0,10	±0,20	Modificado								
	MAS DE 6 A 30 mm	±0,10	±0,20	±0,50	Escala		1:22		RECAMBIOS MMZ-150		Código máquina:		
	MAS DE 30 A 120 mm	±0,15	±0,30	±0,80							CODIGO		
MAS DE 120 A 400 mm	±0,20	±0,50	±1,20										
MAS DE 400 A 1000 mm	±0,30	±0,80	±2,00										
MAS DE 1000 A 2000 mm	±0,50	±1,20	±3,00										



COTAS SIN TOLERANCIA DIN 7168-f						Material: .				COD. PIEZA: 148610000000			
GRADO TOLERANCIA						Acabado: .				SUSTITUYE A: .			
ANGULAR	HASTA 10 mm	FINO	MEDIO	GRUESO					SUSTITUIDO POR: .				
	MAS DE 10 A 50 mm		±1°	±1° 30'	MODELO	Ud.	MODELO	Ud.	MODELO	Ud.	MODELO	Ud.	MODELO
	MAS DE 50 A 120 mm		±30'	±50'	MMZ-202	1							
	MAS DE 120 A 400 mm		±20'	±25'									
LINEAL	MAS DE 400 mm		±10'	±15'									
	MAS DE 3 mm		±5'	±10'									
	MAS DE 6 A 30 mm												
	MAS DE 30 A 120 mm												
	MAS DE 120 A 400 mm												
Material: .						Nombre				Fecha			
Acabado: .						A4				Feb-2011			
Material: .						Dibujado				A.J.GONZALEZ			
Acabado: .						Modificado							
Material: .						Escala				1:25			
Acabado: .						RECAMBIOS MMZ-202				Código máquina:			

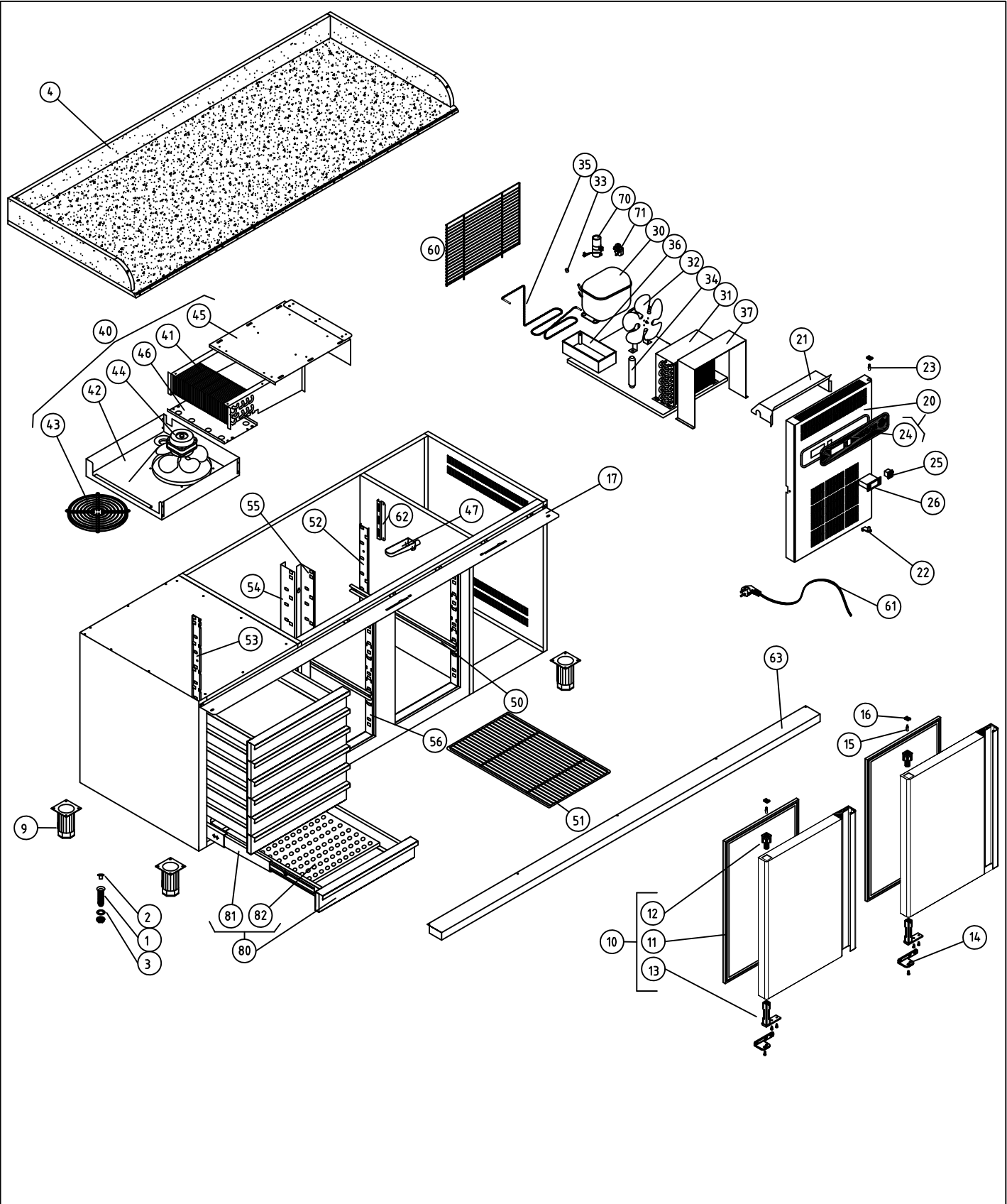



COTAS SIN TOLERANCIA DIN 7168-f						COD. PIEZA: 148312200000								
Material: .						SUSTITUYE A: .								
Acabado: .						SUSTITUIDO POR: .								
ANGULAR	GRADO TOLERANCIA	FINO	MEDIO	GRUESO	COMUN A	MODELO	Ud.	MODELO	Ud.	MODELO	Ud.	MODELO	Ud.	
	HASTA 10 mm		±1°	±1° 30'		MMZ-180-7	1							
	MAS DE 10 A 50 mm		±30'	±50'										
	MAS DE 50 A 120 mm		±20'	±25'										
LINEAL	MAS DE 120 A 400 mm		±10'	±15'										
	MAS DE 400 mm		±5'	±10'										
	GRADO TOLERANCIA	FINO	MEDIO	GRUESO	A4	Nombre	Fecha		 F A G O R I					
	HASTA 3 mm	±0,05	±0,10	±0,15	Dibujado	A.J.GONZALEZ	Feb-2011							
	MAS DE 3 A 6 mm	±0,05	±0,10	±0,20	Modificado									
MAS DE 6 A 30 mm	±0,10	±0,20	±0,50	Escala	1:25		RECAMBIOS MMZ-180-7							
MAS DE 30 A 120 mm	±0,15	±0,30	±0,80			Código máquina:								
MAS DE 120 A 400 mm	±0,20	±0,50	±1,20			CODIGO								
MAS DE 400 A 1000 mm	±0,30	±0,80	±2,00											
MAS DE 1000 A 2000 mm	±0,50	±1,20	±3,00											

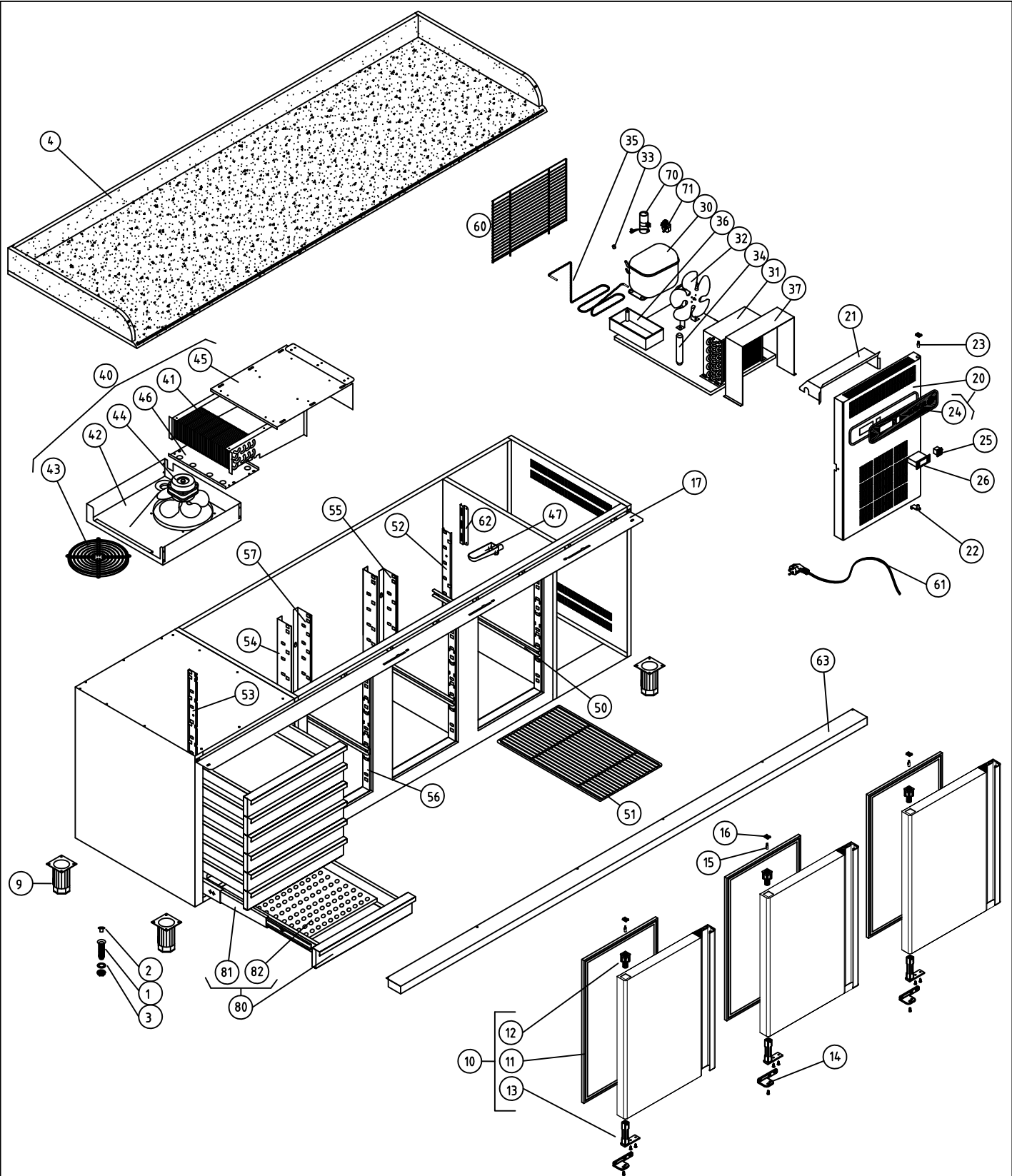

COD. PIEZA: 148313200000

COTAS SIN TOLERANCIA DIN 7168-f

GRADO TOLERANCIA	FINO		MEDIO		GRUESO	
	HASTA 3 mm	MÁS DE 3 A 6 mm	HASTA 10 mm	MÁS DE 10 A 30 mm	HASTA 30 mm	MÁS DE 30 A 120 mm
ANGULAR	±1°	±30'	±1°	±50'	±1° 30'	±25'
LINEAL	±0,05	±0,10	±0,10	±0,20	±0,15	±0,50
	±0,05	±0,10	±0,20	±0,30	±0,20	±0,80
	±0,10	±0,20	±0,30	±0,50	±0,30	±1,20
	±0,15	±0,30	±0,50	±1,00	±0,50	±2,00
	±0,20	±0,50	±1,00	±2,00	±0,50	±3,00

Material:						
Acabado:						
COMUN A	MODELO	Ud.	MODELO	Ud.	MODELO	Ud.
	MMZ-225-7	1				
A4	Nombre	Fecha		FAGOR		
Dibujado	A.J.GONZALEZ	Feb-2011		F A G O R F R I		
Modificado						
Escala	1:25		RECAMBIOS MMZ-225-7			Código máquina:
						CODIGO

SUSTITUYE A:

SUSTITUIDO POR:

Nombre

Fecha

FAGOR

F A G O R F R I

Código máquina:

CODIGO