

DESPIECES

MESAS MFP-GASTRO

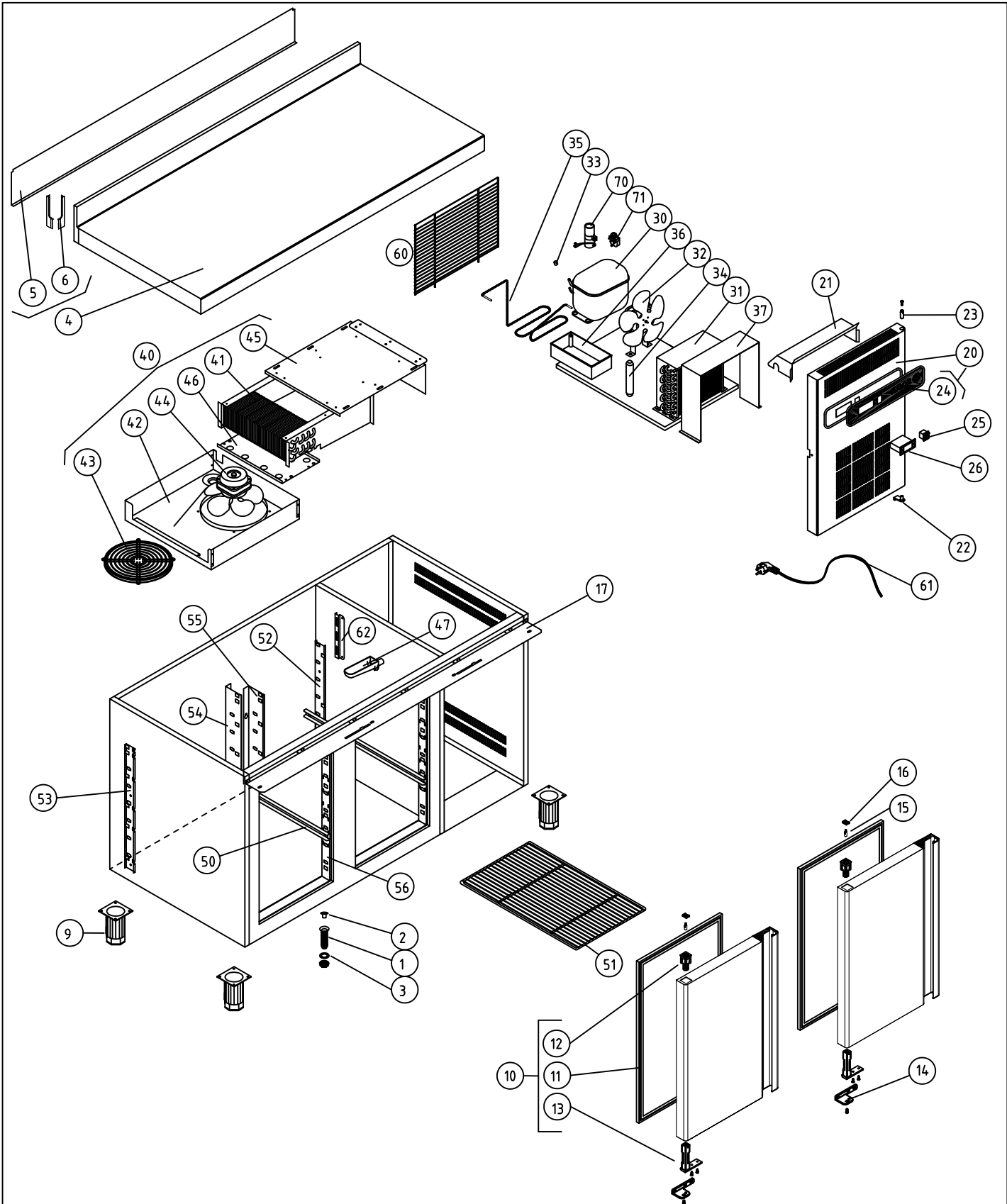

Rev.: Dic-2010



M1 MESAS FRÍAS				COD. PIEZA: 148311000000							
COTAS SIN TOLERANCIA DIN 7168-f				Material: .							
ANGULAR	GRADO TOLERANCIA	FINO	MEDIO	GRUESO	Acabado: .			SUSTITUYE A:			
	HASTA 10 mm		±1°	±1° 30'	SUSTITUIDO POR:						
	MAS DE 10 A 50 mm		±30'	±50'	MODELO	Ud.	MODELO	Ud.	MODELO	Ud.	MODELO
	MAS DE 50 A 120 mm		±20'	±25'	MFP-135-GN	1					
LINEAL	MAS DE 120 A 400 mm		±10'	±15'							
	MAS DE 400 mm		±5'	±10'							
	GRADO TOLERANCIA	FINO	MEDIO	GRUESO	A4		Nombre		Fecha		
	HASTA 3 mm	±0,05	±0,10	±0,15	Dibujado		A.J.GONZALEZ		Dic-2010		
MAS DE 3 A 6 mm	±0,05	±0,10	±0,20	Modificado							
MAS DE 6 A 30 mm	±0,10	±0,20	±0,50	Escala		1:22		RECAMBIOS MFP-135-GN			
MAS DE 30 A 120 mm	±0,15	±0,30	±0,80					Código máquina:			
MAS DE 120 A 400 mm	±0,20	±0,50	±1,20					CODIGO			
MAS DE 400 A 1000 mm	±0,30	±0,80	±2,00								
MAS DE 1000 A 2000 mm	±0,50	±1,20	±3,00								



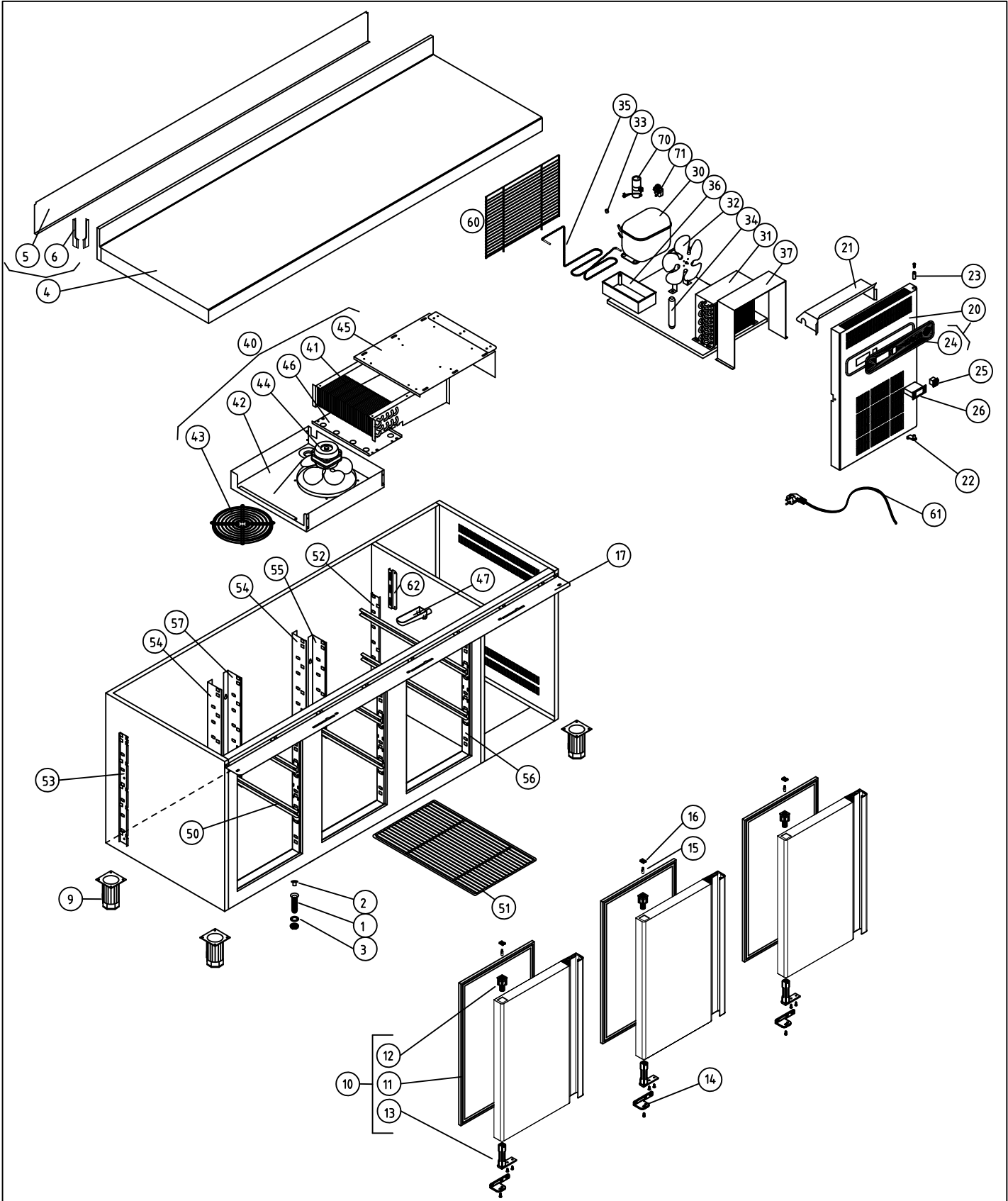

MFP-180-GN				COD. PIEZA: X							
COTAS SIN TOLERANCIA DIN 7168-f				Material: MATERIAL ESPESOR							
				Acabado: ACABADO							
ANGULAR	GRADO TOLERANCIA	FINO	MEDIO	GRUESO	SUSTITUYE A:						
	HASTA 10 mm		±1°	±1° 30'	SUSTITUIDO POR:						
	MAS DE 10 A 50 mm		±30'	±50'	MODELO	Ud.	MODELO	Ud.			
	MAS DE 50 A 120 mm		±20'	±25'	MFP-180	1					
	MAS DE 120 A 400 mm		±10'	±15'							
	MAS DE 400 mm		±5'	±10'							
LINEAL	GRADO TOLERANCIA	FINO	MEDIO	GRUESO	A4		Nombre		Fecha		
	HASTA 3 mm		±0,05	±0,10	±0,15	Dibujado		A.J.GONZALEZ		Dic-2010	
	MAS DE 3 A 6 mm		±0,05	±0,10	±0,20	Modificado					
	MAS DE 6 A 30 mm		±0,10	±0,20	±0,50	Escala		1:25		MFP-180-GN	
	MAS DE 30 A 120 mm		±0,15	±0,30	±0,80					Código máquina:	
	MAS DE 120 A 400 mm		±0,20	±0,50	±1,20					CODIGO	
	MAS DE 400 A 1000 mm		±0,30	±0,80	±2,00						
	MAS DE 1000 A 2000 mm		±0,50	±1,20	±3,00						



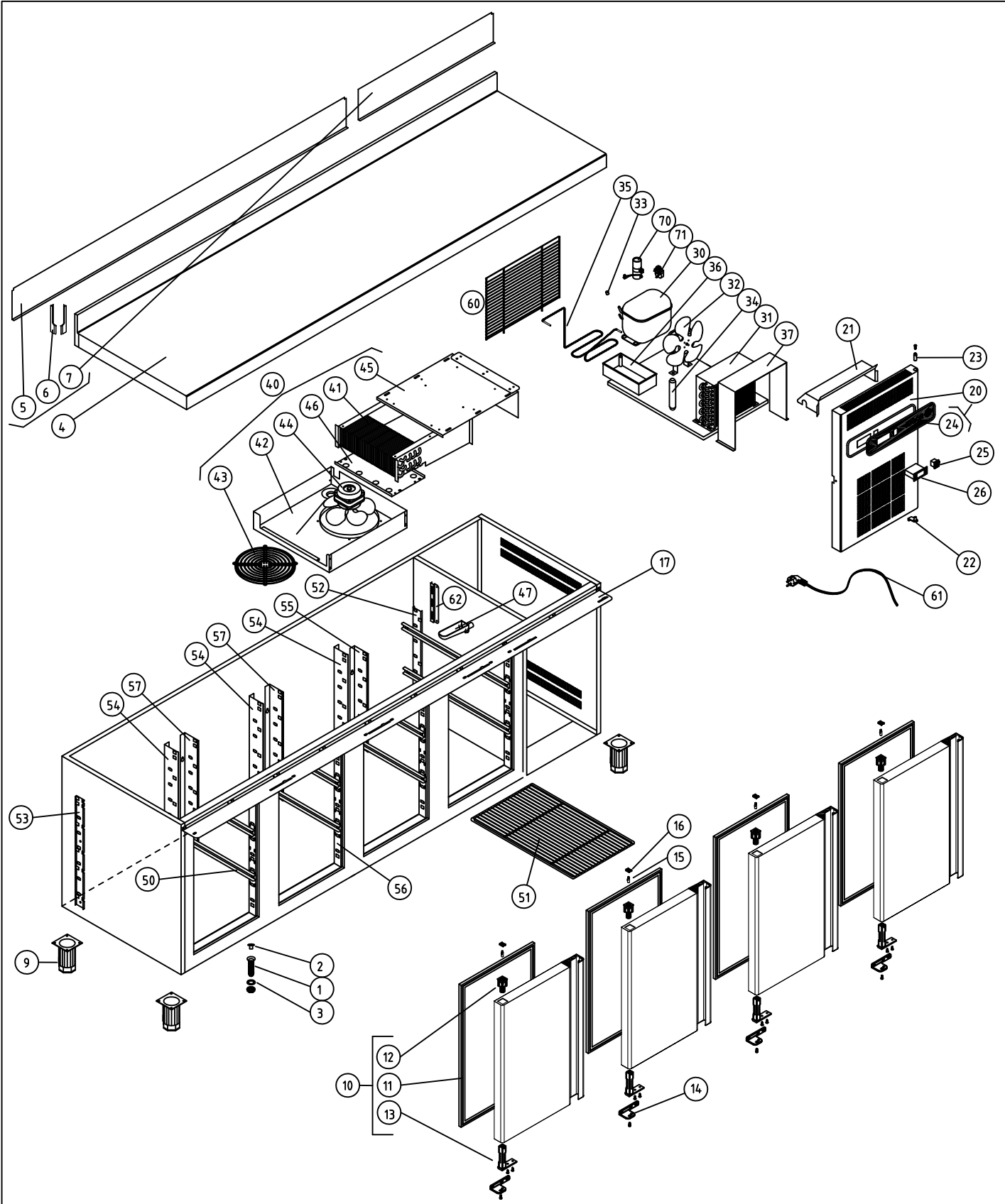

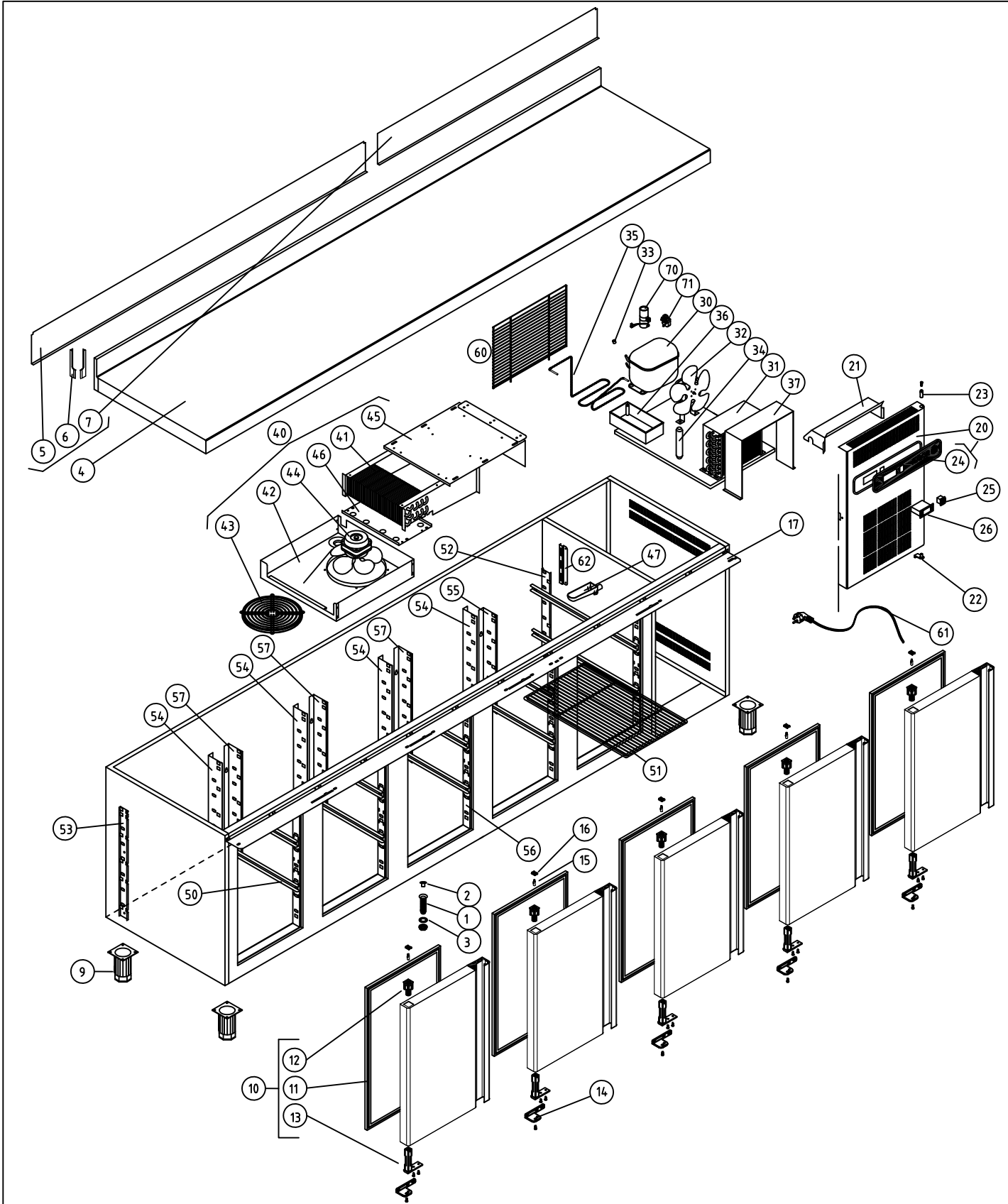

MFP-225-GN					COD. PIEZA: X											
COTAS SIN TOLERANCIA DIN 7168-f					Material: MATERIAL ESPESOR											
					Acabado: ACABADO											
ANGULAR	GRADO TOLERANCIA	FINO	MEDIO	GRUESO	COMUN A	MODELO	Ud.	MODELO	Ud.	MODELO	Ud.	MODELO	Ud.	MODELO	Ud.	
	HASTA 10 mm		±1°	±1° 30'		MFP-225	1									
	MAS DE 10 A 50 mm		±30'	±50'												
	MAS DE 50 A 120 mm		±20'	±25'												
	MAS DE 120 A 400 mm		±10'	±15'												
	MAS DE 400 mm		±5'	±10'												
LINEAL	GRADO TOLERANCIA	FINO	MEDIO	GRUESO	A4	Nombre		Fecha				Código máquina: CODIGO				
	HASTA 3 mm	±0,05	±0,10	±0,15	Dibujado	A.J.GONZALEZ		Dic-2010								
	MAS DE 3 A 6 mm	±0,05	±0,10	±0,20	Modificado											
	MAS DE 6 A 30 mm	±0,10	±0,20	±0,50	Escala	1:25		MFP-225-GN								
	MAS DE 30 A 120 mm	±0,15	±0,30	±0,80												
MAS DE 120 A 400 mm	±0,20	±0,50	±1,20													
MAS DE 400 A 1000 mm	±0,30	±0,80	±2,00													
MAS DE 1000 A 2000 mm	±0,50	±1,20	±3,00													

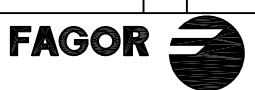

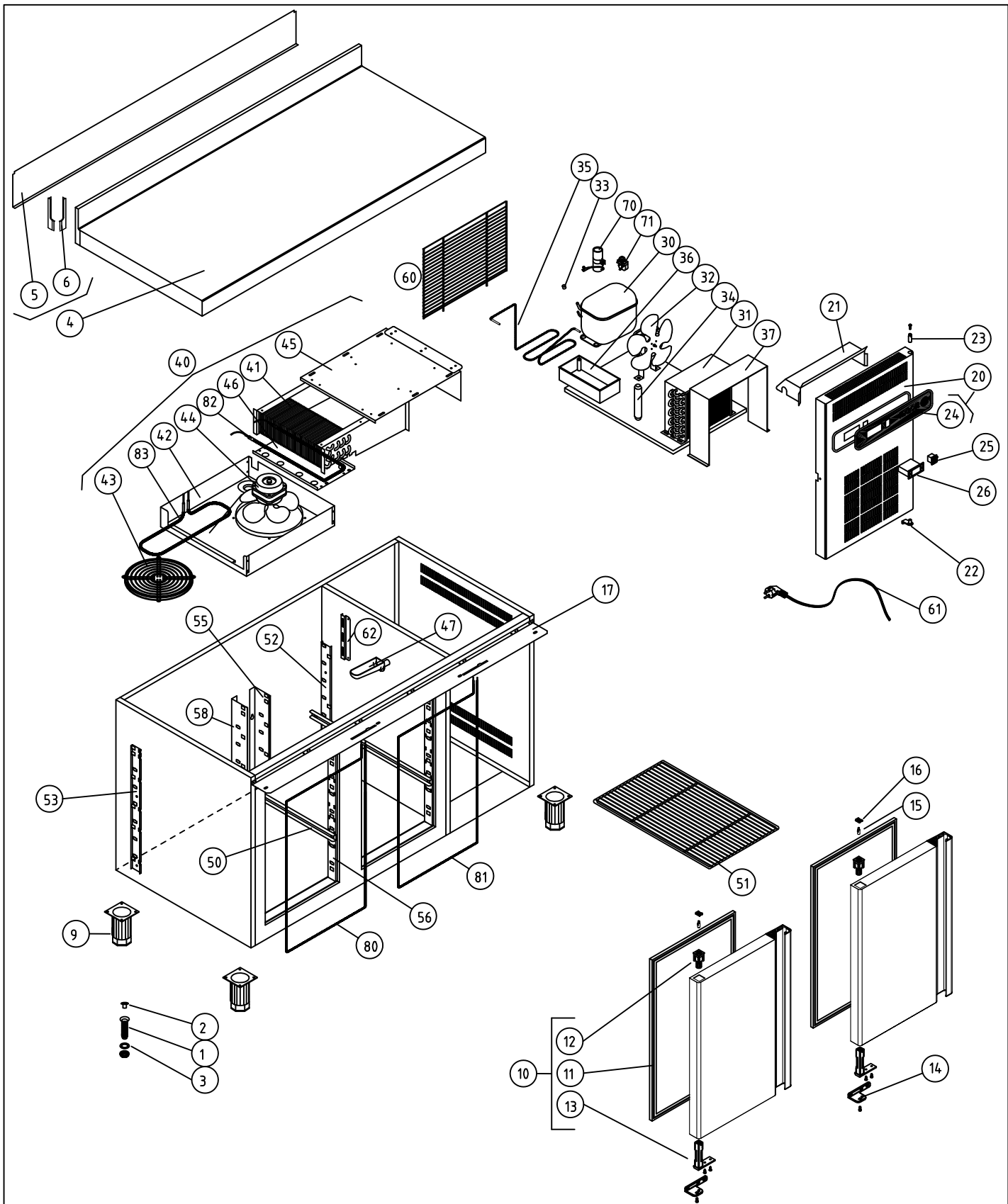
MFP-270-GN				COD. PIEZA: X					
COTAS SIN TOLERANCIA DIN 7168-f				Material: MATERIAL ESPESOR					
				Acabado: ACABADO					
ANGULAR	GRADO TOLERANCIA	FINO	MEDIO	GRUESO					
	HASTA 10 mm		±1°	±1° 30'					
	MAS DE 10 A 50 mm		±30'	±50'					
	MAS DE 50 A 120 mm		±20'	±25'					
LINEAL	GRADO TOLERANCIA	FINO	MEDIO	GRUESO					
	HASTA 3 mm		±0,05	±0,10	±0,15				
	MAS DE 3 A 6 mm		±0,05	±0,10	±0,20				
	MAS DE 6 A 30 mm		±0,10	±0,20	±0,50				
COMUN A	MAS DE 30 A 120 mm		±0,15	±0,30	±0,80				
	MAS DE 120 A 400 mm		±0,20	±0,50	±1,20				
	MAS DE 400 A 1000 mm		±0,30	±0,80	±2,00				
	MAS DE 1000 A 2000 mm		±0,50	±1,20	±3,00				
A4		Nombre		Fecha		 F A G O F R I			
Dibujado		A.J.GONZALEZ		Dic-2010					
Modificado									
Escala		1:25		MFP-270-GN				Código máquina: CODIGO	



M1 MESAS FRÍAS				COD. PIEZA: 148321000000												
COTAS SIN TOLERANCIA DIN 7168-f				Material: MATERIAL ESPESOR												
Material: MATERIAL ESPESOR				SUSTITUYE A:												
Acabado: ACABADO				SUSTITUIDO POR:												
ANGULAR	GRADO TOLERANCIA	FINO	MEDIO	GRUESO	COMUN A	MODELO	Ud.	MODELO	Ud.	MODELO	Ud.	MODELO	Ud.	MODELO	Ud.	
	HASTA 10 mm		±1°	±1° 30'		MFN-135	1									
	MAS DE 10 A 50 mm		±30'	±50'												
	MAS DE 50 A 120 mm		±20'	±25'												
LINEAL	MAS DE 120 A 400 mm		±10'	±15'												
	MAS DE 400 mm		±5'	±10'												
	GRADO TOLERANCIA	FINO	MEDIO	GRUESO	A4	Nombre	Fecha	 F A G O R I								
	HASTA 3 mm	±0,05	±0,10	±0,15	Dibujado	A.J.GONZALEZ	DIC-2010									
	MAS DE 3 A 6 mm	±0,05	±0,10	±0,20	Modificado											
	MAS DE 6 A 30 mm	±0,10	±0,20	±0,50	Escala	1:22		RECAMBIOS MFN-135								
MAS DE 30 A 120 mm	±0,15	±0,30	±0,80		Código máquina: CODIGO											
MAS DE 120 A 400 mm	±0,20	±0,50	±1,20													
MAS DE 400 A 1000 mm	±0,30	±0,80	±2,00													
MAS DE 1000 A 2000 mm	±0,50	±1,20	±3,00													

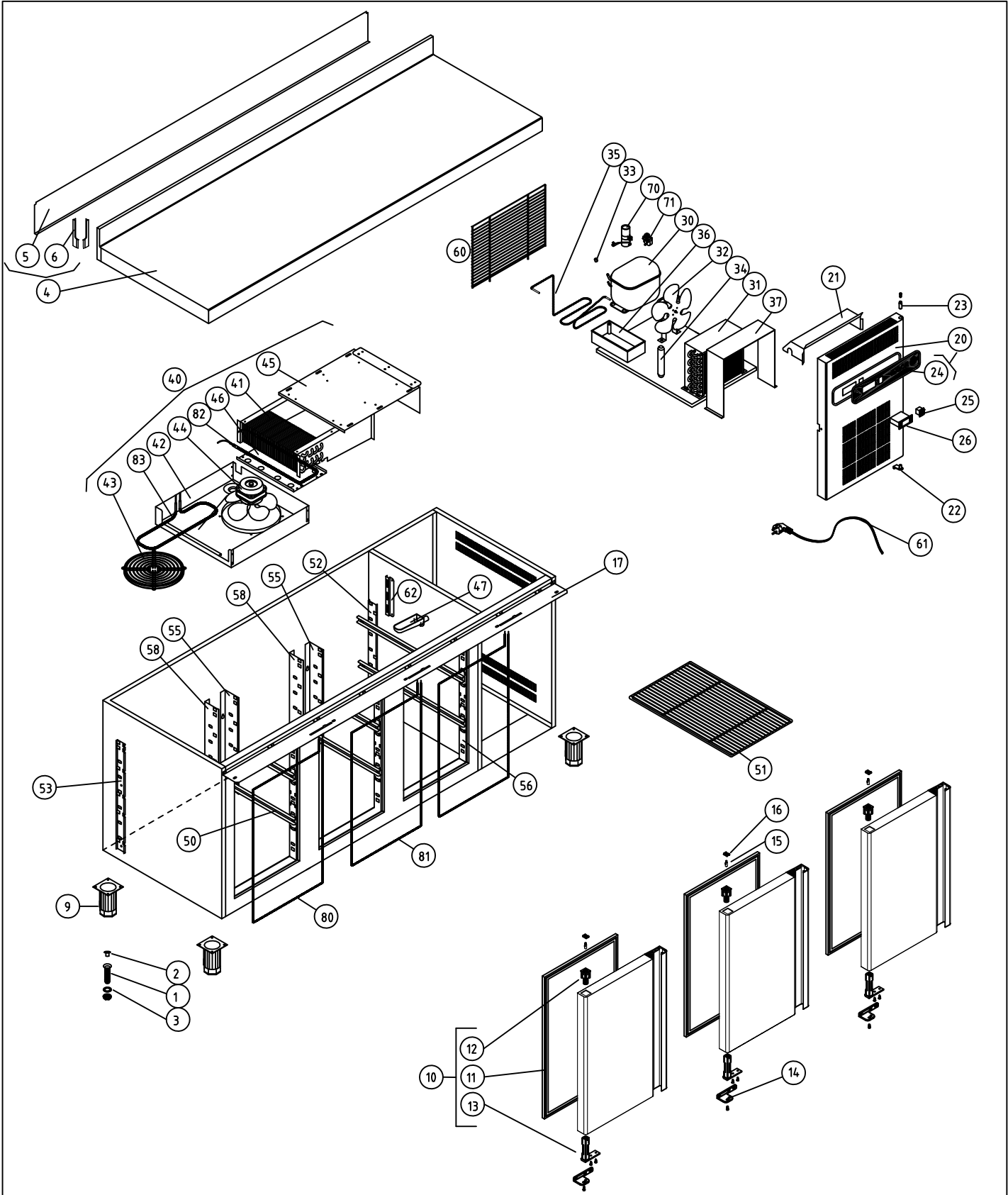

MFN-180				COD. PIEZA: 14832200000							
COTAS SIN TOLERANCIA DIN 7168-f				Material: MATERIAL ESPESOR							
				Acabado: ACABADO							
ANGULAR	GRADO TOLERANCIA	FINO	MEDIO	GRUESO	COMUN A			SUSTITUYE A:			
	HASTA 10 mm				MODELO	Ud.	MODELO	Ud.	MODELO	Ud.	MODELO
	MAS DE 10 A 50 mm	±30'		±50'	MFN-180-GN	1					
	MAS DE 50 A 120 mm	±20'		±25'							
	MAS DE 120 A 400 mm	±10'		±15'							
	MAS DE 400 mm	±5'		±10'							
LINEAL	GRADO TOLERANCIA	FINO	MEDIO	GRUESO	A4		Nombre		Fecha		
	HASTA 3 mm	±0,05	±0,10	±0,15	Dibujado		A.J.GONZALEZ		28-4-08		
	MAS DE 3 A 6 mm	±0,05	±0,10	±0,20	Modificado						
	MAS DE 6 A 30 mm	±0,10	±0,20	±0,50	Escala		1:25		MFN-180-GN		
	MAS DE 30 A 120 mm	±0,15	±0,30	±0,80					Código máquina:		
	MAS DE 120 A 400 mm	±0,20	±0,50	±1,20					CODIGO		
	MAS DE 400 A 1000 mm	±0,30	±0,80	±2,00							
	MAS DE 1000 A 2000 mm	±0,50	±1,20	±3,00							



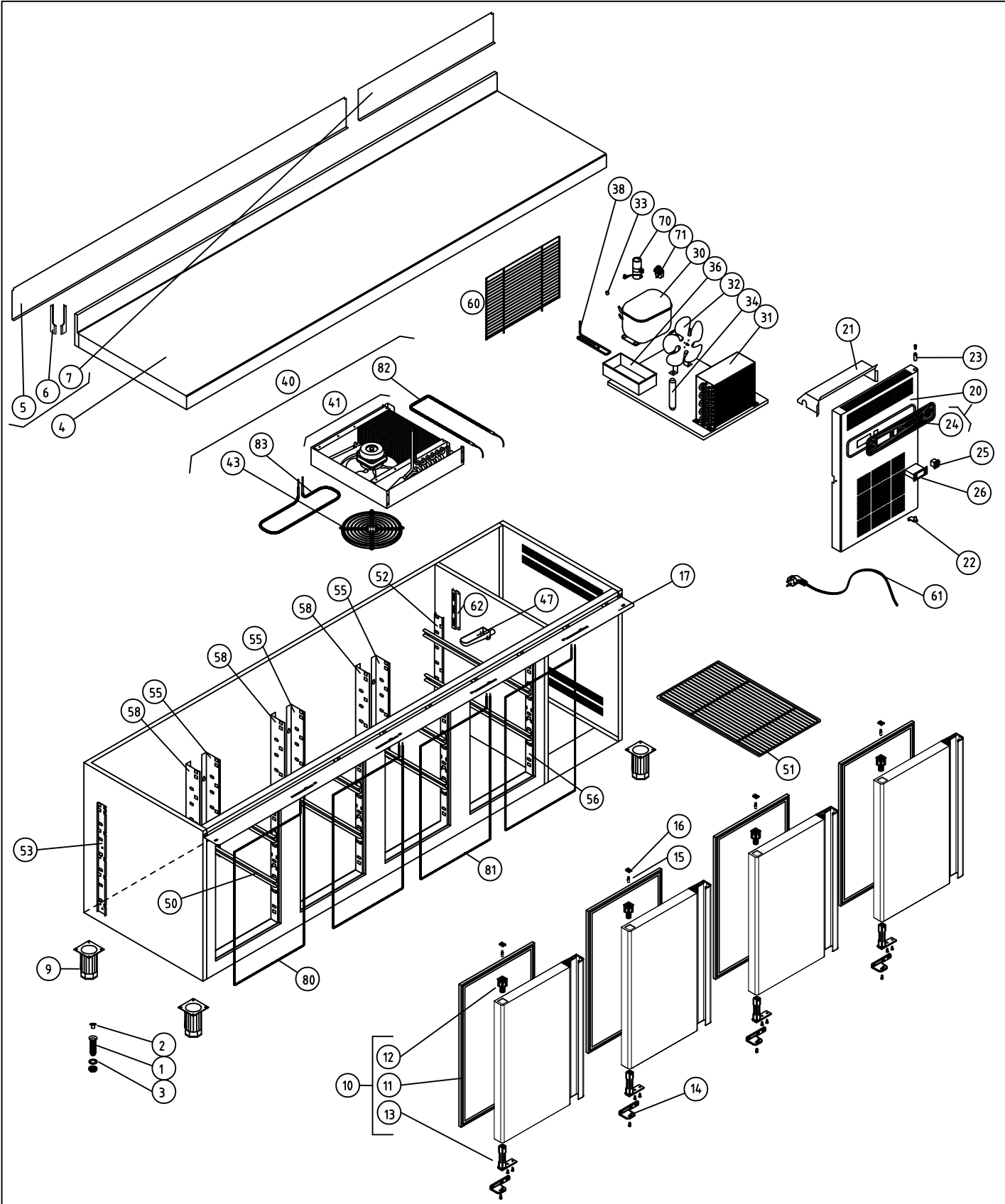

MFN-225-GN				COD. PIEZA: X																											
COTAS SIN TOLERANCIA DIN 7168-f				Material: MATERIAL ESPESOR																											
<table border="1"> <thead> <tr> <th>GRADO TOLERANCIA</th> <th>FINO</th> <th>MEDIO</th> <th>GRUESO</th> </tr> </thead> <tbody> <tr> <td>HASTA 10 mm</td> <td>±1°</td> <td></td> <td>±1° 30'</td> </tr> <tr> <td>MAS DE 10 A 50 mm</td> <td>±30'</td> <td></td> <td>±50'</td> </tr> <tr> <td>MAS DE 50 A 120 mm</td> <td>±20'</td> <td></td> <td>±25'</td> </tr> <tr> <td>MAS DE 120 A 400 mm</td> <td>±10'</td> <td></td> <td>±15'</td> </tr> <tr> <td>MAS DE 400 mm</td> <td>±5'</td> <td></td> <td>±10'</td> </tr> </tbody> </table>				GRADO TOLERANCIA	FINO	MEDIO	GRUESO	HASTA 10 mm	±1°		±1° 30'	MAS DE 10 A 50 mm	±30'		±50'	MAS DE 50 A 120 mm	±20'		±25'	MAS DE 120 A 400 mm	±10'		±15'	MAS DE 400 mm	±5'		±10'	Acabado: ACABADO			
GRADO TOLERANCIA	FINO	MEDIO	GRUESO																												
HASTA 10 mm	±1°		±1° 30'																												
MAS DE 10 A 50 mm	±30'		±50'																												
MAS DE 50 A 120 mm	±20'		±25'																												
MAS DE 120 A 400 mm	±10'		±15'																												
MAS DE 400 mm	±5'		±10'																												
ANGULAR	COMUN A		MODELO	Ud.	MODELO	Ud.	MODELO	Ud.	MODELO	Ud.																					
			MFN-225	1																											
LINEAL	GRADO TOLERANCIA	FINO	MEDIO	GRUESO	A4		Nombre		Fecha																						
	HASTA 3 mm	±0,05	±0,10	±0,15	Dibujado		A.J.GONZALEZ		Dic-2010																						
	MAS DE 3 A 6 mm	±0,05	±0,10	±0,20	Modificado																										
	MAS DE 6 A 30 mm	±0,10	±0,20	±0,50	Escala		1:25		MFN-225-GN																						
	MAS DE 30 A 120 mm	±0,15	±0,30	±0,80					Código máquina: CODIGO																						
MAS DE 120 A 400 mm	±0,20	±0,50	±1,20																												
MAS DE 400 A 1000 mm	±0,30	±0,80	±2,00																												
MAS DE 1000 A 2000 mm	±0,50	±1,20	±3,00																												



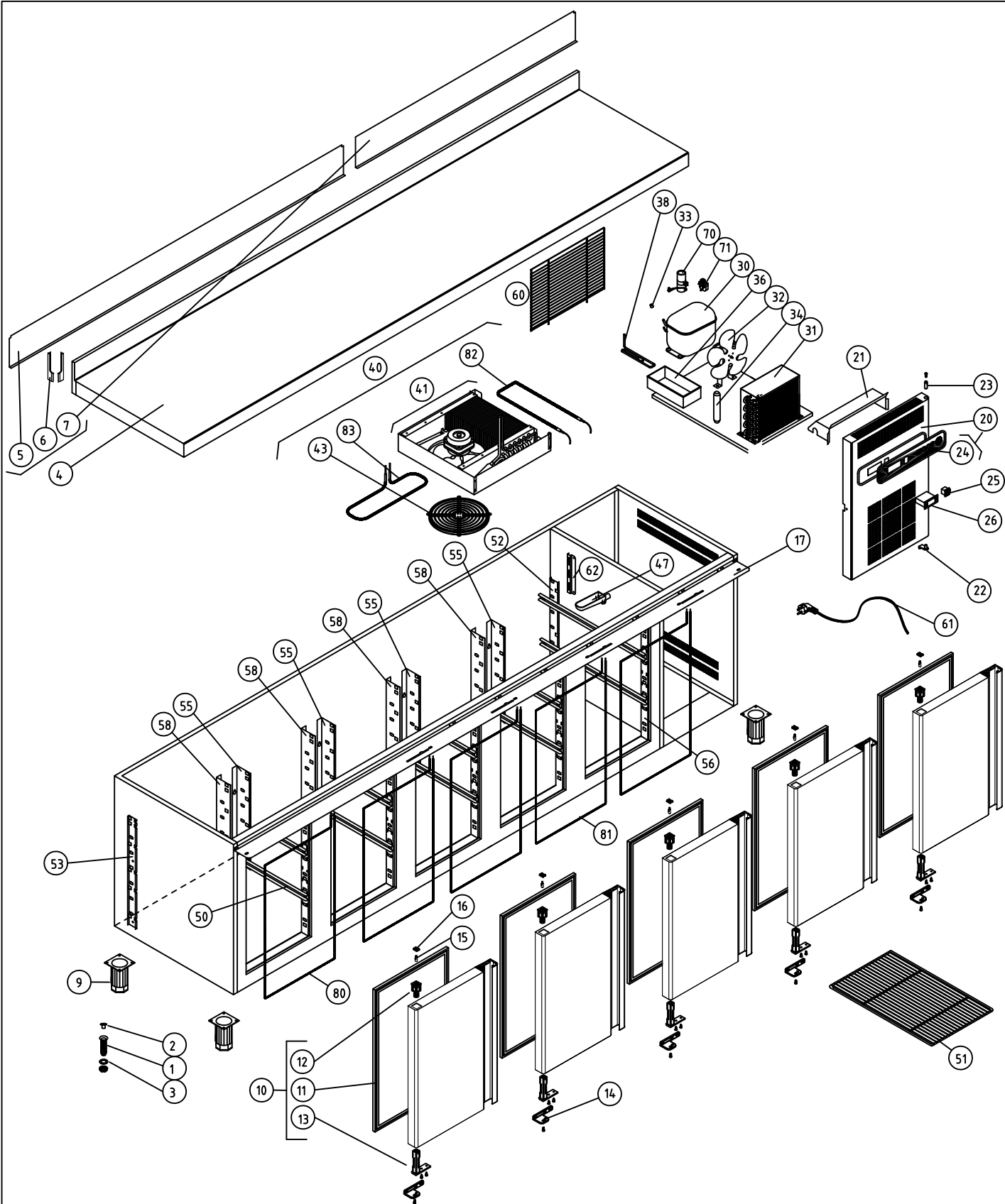

MFN-270-GN				COD. PIEZA: X							
COTAS SIN TOLERANCIA DIN 7168-f				Material: MATERIAL ESPESOR							
				Acabado: ACABADO							
ANGULAR	GRADO TOLERANCIA	FINO	MEDIO	GRUESO	COMUN A			SUSTITUYE A:			
	HASTA 10 mm		±1°	±1° 30'	MODELO	Ud.	MODELO	Ud.	MODELO	Ud.	MODELO
	MAS DE 10 A 50 mm		±30'	±50'	MFN-270-GN	1					
	MAS DE 50 A 120 mm		±20'	±25'							
	MAS DE 120 A 400 mm		±10'	±15'							
	MAS DE 400 mm		±5'	±10'							
LINEAL	GRADO TOLERANCIA	FINO	MEDIO	GRUESO	A4		Nombre		Fecha		
	HASTA 3 mm		±0,05	±0,10	±0,15	Dibujado		A.J.GONZALEZ		Dic-2010	
	MAS DE 3 A 6 mm		±0,05	±0,10	±0,20	Modificado					
	MAS DE 6 A 30 mm		±0,10	±0,20	±0,50	Escala		1:25		MFN-270-GN	
	MAS DE 30 A 120 mm		±0,15	±0,30	±0,80					Código máquina:	
	MAS DE 120 A 400 mm		±0,20	±0,50	±1,20					CODIGO	
	MAS DE 400 A 1000 mm		±0,30	±0,80	±2,00						
	MAS DE 1000 A 2000 mm		±0,50	±1,20	±3,00						



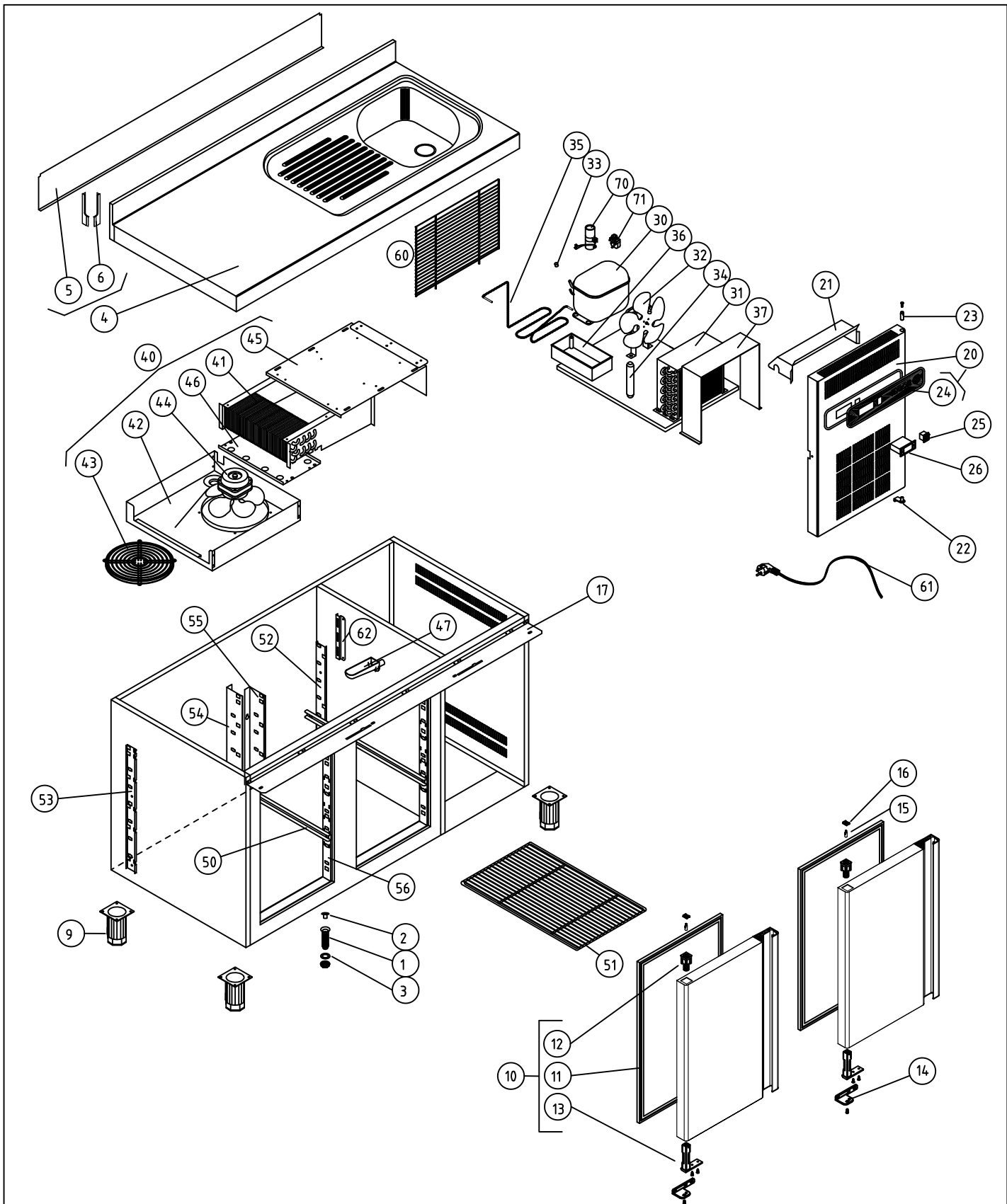

M1 MESAS FRÍAS						COD. PIEZA: 148311030000																																																																																							
COTAS SIN TOLERANCIA DIN 7168-f						Material: MATERIAL ESPESOR																																																																																							
<table border="1"> <thead> <tr> <th>GRADO TOLERANCIA</th> <th>FINO</th> <th>MEDIO</th> <th>GRUESO</th> </tr> </thead> <tbody> <tr> <td>HASTA 10 mm</td> <td></td> <td>±1°</td> <td>±1° 30'</td> </tr> <tr> <td>MAS DE 10 A 50 mm</td> <td></td> <td>±30'</td> <td>±50'</td> </tr> <tr> <td>MAS DE 50 A 120 mm</td> <td></td> <td>±20'</td> <td>±25'</td> </tr> <tr> <td>MAS DE 120 A 400 mm</td> <td></td> <td>±10'</td> <td>±15'</td> </tr> <tr> <td>MAS DE 400 mm</td> <td></td> <td>±5'</td> <td>±10'</td> </tr> </tbody> </table>						GRADO TOLERANCIA	FINO	MEDIO	GRUESO	HASTA 10 mm		±1°	±1° 30'	MAS DE 10 A 50 mm		±30'	±50'	MAS DE 50 A 120 mm		±20'	±25'	MAS DE 120 A 400 mm		±10'	±15'	MAS DE 400 mm		±5'	±10'	Acabado: ACABADO				SUSTITUYE A:																																																											
GRADO TOLERANCIA	FINO	MEDIO	GRUESO																																																																																										
HASTA 10 mm		±1°	±1° 30'																																																																																										
MAS DE 10 A 50 mm		±30'	±50'																																																																																										
MAS DE 50 A 120 mm		±20'	±25'																																																																																										
MAS DE 120 A 400 mm		±10'	±15'																																																																																										
MAS DE 400 mm		±5'	±10'																																																																																										
<table border="1"> <thead> <tr> <th>ANGULAR</th> <th>GRADO TOLERANCIA</th> <th>FINO</th> <th>MEDIO</th> <th>GRUESO</th> </tr> </thead> <tbody> <tr> <td></td> <td>HASTA 3 mm</td> <td>±0,05</td> <td>±0,10</td> <td>±0,15</td> </tr> <tr> <td></td> <td>MAS DE 3 A 6 mm</td> <td>±0,05</td> <td>±0,10</td> <td>±0,20</td> </tr> <tr> <td></td> <td>MAS DE 6 A 30 mm</td> <td>±0,10</td> <td>±0,20</td> <td>±0,50</td> </tr> <tr> <td></td> <td>MAS DE 30 A 120 mm</td> <td>±0,15</td> <td>±0,30</td> <td>±0,80</td> </tr> <tr> <td></td> <td>MAS DE 120 A 400 mm</td> <td>±0,20</td> <td>±0,50</td> <td>±1,20</td> </tr> <tr> <td></td> <td>MAS DE 400 A 1000 mm</td> <td>±0,30</td> <td>±0,80</td> <td>±2,00</td> </tr> <tr> <td></td> <td>MAS DE 1000 A 2000 mm</td> <td>±0,50</td> <td>±1,20</td> <td>±3,00</td> </tr> </tbody> </table>						ANGULAR	GRADO TOLERANCIA	FINO	MEDIO	GRUESO		HASTA 3 mm	±0,05	±0,10	±0,15		MAS DE 3 A 6 mm	±0,05	±0,10	±0,20		MAS DE 6 A 30 mm	±0,10	±0,20	±0,50		MAS DE 30 A 120 mm	±0,15	±0,30	±0,80		MAS DE 120 A 400 mm	±0,20	±0,50	±1,20		MAS DE 400 A 1000 mm	±0,30	±0,80	±2,00		MAS DE 1000 A 2000 mm	±0,50	±1,20	±3,00	<table border="1"> <thead> <tr> <th>COMUN A</th> <th>MODELO</th> <th>Ud.</th> <th>MODELO</th> <th>Ud.</th> <th>MODELO</th> <th>Ud.</th> <th>MODELO</th> <th>Ud.</th> <th>MODELO</th> </tr> </thead> <tbody> <tr> <td></td> <td>MFP-135-GN/F 1</td> <td></td> <td></td> <td></td> <td></td> <td></td> <td></td> <td></td> <td></td> </tr> <tr> <td></td> <td></td> <td></td> <td></td> <td></td> <td></td> <td></td> <td></td> <td></td> <td></td> </tr> <tr> <td></td> <td></td> <td></td> <td></td> <td></td> <td></td> <td></td> <td></td> <td></td> <td></td> </tr> </tbody> </table>				COMUN A	MODELO	Ud.	MODELO	Ud.	MODELO	Ud.	MODELO	Ud.	MODELO		MFP-135-GN/F 1																													SUSTITUIDO POR:			
						ANGULAR	GRADO TOLERANCIA	FINO	MEDIO	GRUESO																																																																																			
							HASTA 3 mm	±0,05	±0,10	±0,15																																																																																			
	MAS DE 3 A 6 mm	±0,05	±0,10	±0,20																																																																																									
	MAS DE 6 A 30 mm	±0,10	±0,20	±0,50																																																																																									
	MAS DE 30 A 120 mm	±0,15	±0,30	±0,80																																																																																									
	MAS DE 120 A 400 mm	±0,20	±0,50	±1,20																																																																																									
	MAS DE 400 A 1000 mm	±0,30	±0,80	±2,00																																																																																									
	MAS DE 1000 A 2000 mm	±0,50	±1,20	±3,00																																																																																									
COMUN A	MODELO	Ud.	MODELO	Ud.	MODELO	Ud.	MODELO	Ud.	MODELO																																																																																				
	MFP-135-GN/F 1																																																																																												
<table border="1"> <thead> <tr> <th>LINEAL</th> <th>GRADO TOLERANCIA</th> <th>FINO</th> <th>MEDIO</th> <th>GRUESO</th> </tr> </thead> <tbody> <tr> <td></td> <td>HASTA 3 mm</td> <td>±0,05</td> <td>±0,10</td> <td>±0,15</td> </tr> <tr> <td></td> <td>MAS DE 3 A 6 mm</td> <td>±0,05</td> <td>±0,10</td> <td>±0,20</td> </tr> <tr> <td></td> <td>MAS DE 6 A 30 mm</td> <td>±0,10</td> <td>±0,20</td> <td>±0,50</td> </tr> <tr> <td></td> <td>MAS DE 30 A 120 mm</td> <td>±0,15</td> <td>±0,30</td> <td>±0,80</td> </tr> <tr> <td></td> <td>MAS DE 120 A 400 mm</td> <td>±0,20</td> <td>±0,50</td> <td>±1,20</td> </tr> <tr> <td></td> <td>MAS DE 400 A 1000 mm</td> <td>±0,30</td> <td>±0,80</td> <td>±2,00</td> </tr> <tr> <td></td> <td>MAS DE 1000 A 2000 mm</td> <td>±0,50</td> <td>±1,20</td> <td>±3,00</td> </tr> </tbody> </table>						LINEAL	GRADO TOLERANCIA	FINO	MEDIO	GRUESO		HASTA 3 mm	±0,05	±0,10	±0,15		MAS DE 3 A 6 mm	±0,05	±0,10	±0,20		MAS DE 6 A 30 mm	±0,10	±0,20	±0,50		MAS DE 30 A 120 mm	±0,15	±0,30	±0,80		MAS DE 120 A 400 mm	±0,20	±0,50	±1,20		MAS DE 400 A 1000 mm	±0,30	±0,80	±2,00		MAS DE 1000 A 2000 mm	±0,50	±1,20	±3,00	A4		Nombre		Fecha																																											
LINEAL	GRADO TOLERANCIA	FINO	MEDIO	GRUESO																																																																																									
	HASTA 3 mm	±0,05	±0,10	±0,15																																																																																									
	MAS DE 3 A 6 mm	±0,05	±0,10	±0,20																																																																																									
	MAS DE 6 A 30 mm	±0,10	±0,20	±0,50																																																																																									
	MAS DE 30 A 120 mm	±0,15	±0,30	±0,80																																																																																									
	MAS DE 120 A 400 mm	±0,20	±0,50	±1,20																																																																																									
	MAS DE 400 A 1000 mm	±0,30	±0,80	±2,00																																																																																									
	MAS DE 1000 A 2000 mm	±0,50	±1,20	±3,00																																																																																									
Dibujado		A.J.GONZALEZ		28/04/2008																																																																																									
Modificado																																																																																													
Escala		1:22		RECAMBIOS MFP-135-GN / F				Código máquina: CODIGO																																																																																					

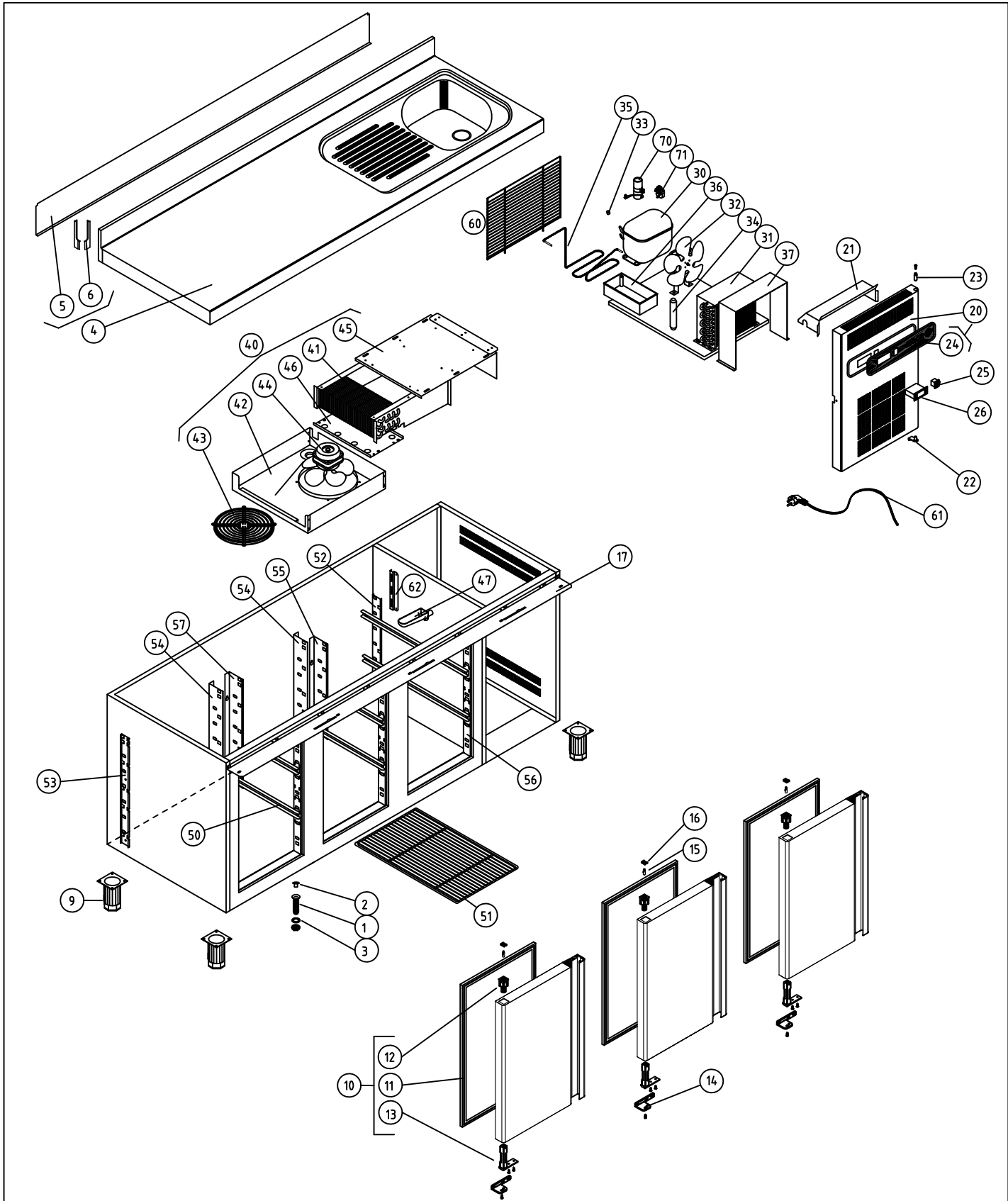

MFP-180-GN /F				COD. PIEZA: 148312030000							
COTAS SIN TOLERANCIA DIN 7168-f				Material: MATERIAL ESPESOR							
				Acabado: ACABADO							
ANGULAR	GRADO TOLERANCIA	FINO	MEDIO	GRUESO	SUSTITUYE A:			SUSTITUIDO POR:			
	HASTA 10 mm		±1°	±1° 30'	MODELO	Ud.	MODELO	Ud.	MODELO	Ud.	MODELO
	MAS DE 10 A 50 mm		±30'	±50'	MFP-180-F	1					
	MAS DE 50 A 120 mm		±20'	±25'							
	MAS DE 120 A 400 mm		±10'	±15'							
	MAS DE 400 mm		±5'	±10'							
LINEAL	GRADO TOLERANCIA	FINO	MEDIO	GRUESO	Nombre			Fecha			
	HASTA 3 mm		±0,05	±0,10	±0,15	A4			Dic-2010		
	MAS DE 3 A 6 mm		±0,05	±0,10	±0,20	Dibujado			A.J.GONZALEZ		
	MAS DE 6 A 30 mm		±0,10	±0,20	±0,50	Modificado					
	MAS DE 30 A 120 mm		±0,15	±0,30	±0,80	Escala			1:25		
	MAS DE 120 A 400 mm		±0,20	±0,50	±1,20						
	MAS DE 400 A 1000 mm		±0,30	±0,80	±2,00						
	MAS DE 1000 A 2000 mm		±0,50	±1,20	±3,00						
								Código máquina: CODIGO			

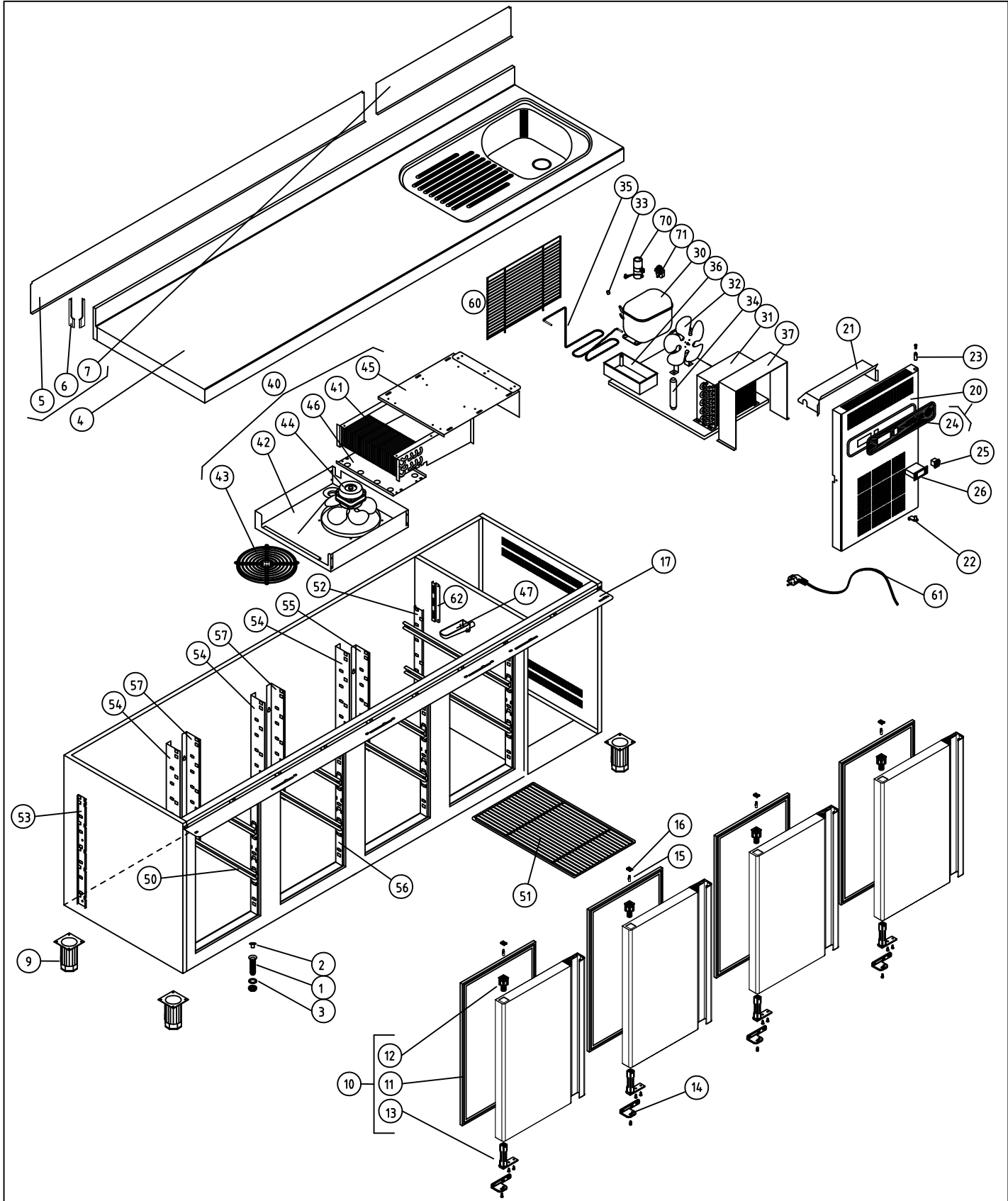

MFP-225-GN_F					COD. PIEZA: X																																																					
COTAS SIN TOLERANCIA DIN 7168-f					Material: MATERIAL ESPESOR																																																					
<table border="1"> <thead> <tr> <th>GRADO TOLERANCIA</th> <th>FINO</th> <th>MEDIO</th> <th>GRUESO</th> </tr> </thead> <tbody> <tr> <td>HASTA 10 mm</td> <td>±1°</td> <td></td> <td>±1° 30'</td> </tr> <tr> <td>MAS DE 10 A 50 mm</td> <td>±30'</td> <td></td> <td>±50'</td> </tr> <tr> <td>MAS DE 50 A 120 mm</td> <td>±20'</td> <td></td> <td>±25'</td> </tr> <tr> <td>MAS DE 120 A 400 mm</td> <td>±10'</td> <td></td> <td>±15'</td> </tr> <tr> <td>MAS DE 400 mm</td> <td>±5'</td> <td></td> <td>±10'</td> </tr> </tbody> </table>					GRADO TOLERANCIA	FINO	MEDIO	GRUESO	HASTA 10 mm	±1°		±1° 30'	MAS DE 10 A 50 mm	±30'		±50'	MAS DE 50 A 120 mm	±20'		±25'	MAS DE 120 A 400 mm	±10'		±15'	MAS DE 400 mm	±5'		±10'	Acabado: ACABADO																													
GRADO TOLERANCIA	FINO	MEDIO	GRUESO																																																							
HASTA 10 mm	±1°		±1° 30'																																																							
MAS DE 10 A 50 mm	±30'		±50'																																																							
MAS DE 50 A 120 mm	±20'		±25'																																																							
MAS DE 120 A 400 mm	±10'		±15'																																																							
MAS DE 400 mm	±5'		±10'																																																							
<table border="1"> <thead> <tr> <th>ANGULAR</th> <th>GRADO TOLERANCIA</th> <th>FINO</th> <th>MEDIO</th> <th>GRUESO</th> </tr> </thead> <tbody> <tr> <td></td> <td>HASTA 3 mm</td> <td>±0,05</td> <td>±0,10</td> <td>±0,15</td> </tr> <tr> <td></td> <td>MAS DE 3 A 6 mm</td> <td>±0,05</td> <td>±0,10</td> <td>±0,20</td> </tr> <tr> <td></td> <td>MAS DE 6 A 30 mm</td> <td>±0,10</td> <td>±0,20</td> <td>±0,50</td> </tr> <tr> <td></td> <td>MAS DE 30 A 120 mm</td> <td>±0,15</td> <td>±0,30</td> <td>±0,80</td> </tr> <tr> <td></td> <td>MAS DE 120 A 400 mm</td> <td>±0,20</td> <td>±0,50</td> <td>±1,20</td> </tr> <tr> <td></td> <td>MAS DE 400 A 1000 mm</td> <td>±0,30</td> <td>±0,80</td> <td>±2,00</td> </tr> <tr> <td></td> <td>MAS DE 1000 A 2000 mm</td> <td>±0,50</td> <td>±1,20</td> <td>±3,00</td> </tr> </tbody> </table>					ANGULAR	GRADO TOLERANCIA	FINO	MEDIO	GRUESO		HASTA 3 mm	±0,05	±0,10	±0,15		MAS DE 3 A 6 mm	±0,05	±0,10	±0,20		MAS DE 6 A 30 mm	±0,10	±0,20	±0,50		MAS DE 30 A 120 mm	±0,15	±0,30	±0,80		MAS DE 120 A 400 mm	±0,20	±0,50	±1,20		MAS DE 400 A 1000 mm	±0,30	±0,80	±2,00		MAS DE 1000 A 2000 mm	±0,50	±1,20	±3,00	SUSTITUYE A:													
					ANGULAR	GRADO TOLERANCIA	FINO	MEDIO	GRUESO																																																	
	HASTA 3 mm	±0,05	±0,10	±0,15																																																						
	MAS DE 3 A 6 mm	±0,05	±0,10	±0,20																																																						
	MAS DE 6 A 30 mm	±0,10	±0,20	±0,50																																																						
	MAS DE 30 A 120 mm	±0,15	±0,30	±0,80																																																						
	MAS DE 120 A 400 mm	±0,20	±0,50	±1,20																																																						
	MAS DE 400 A 1000 mm	±0,30	±0,80	±2,00																																																						
	MAS DE 1000 A 2000 mm	±0,50	±1,20	±3,00																																																						
<table border="1"> <thead> <tr> <th>COMUN A</th> <th>MODELO</th> <th>Ud.</th> <th>MODELO</th> <th>Ud.</th> <th>MODELO</th> <th>Ud.</th> <th>MODELO</th> <th>Ud.</th> <th>MODELO</th> </tr> </thead> <tbody> <tr> <td></td> <td>MFP-225-F</td> <td>1</td> <td></td> <td></td> <td></td> <td></td> <td></td> <td></td> <td></td> </tr> </tbody> </table>					COMUN A	MODELO	Ud.	MODELO	Ud.	MODELO	Ud.	MODELO	Ud.	MODELO		MFP-225-F	1								SUSTITUIDO POR:																																	
					COMUN A	MODELO	Ud.	MODELO	Ud.	MODELO	Ud.	MODELO	Ud.	MODELO																																												
	MFP-225-F	1																																																								
<table border="1"> <thead> <tr> <th>LINEAL</th> <th>GRADO TOLERANCIA</th> <th>FINO</th> <th>MEDIO</th> <th>GRUESO</th> </tr> </thead> <tbody> <tr> <td></td> <td>HASTA 3 mm</td> <td>±0,05</td> <td>±0,10</td> <td>±0,15</td> </tr> <tr> <td></td> <td>MAS DE 3 A 6 mm</td> <td>±0,05</td> <td>±0,10</td> <td>±0,20</td> </tr> <tr> <td></td> <td>MAS DE 6 A 30 mm</td> <td>±0,10</td> <td>±0,20</td> <td>±0,50</td> </tr> <tr> <td></td> <td>MAS DE 30 A 120 mm</td> <td>±0,15</td> <td>±0,30</td> <td>±0,80</td> </tr> <tr> <td></td> <td>MAS DE 120 A 400 mm</td> <td>±0,20</td> <td>±0,50</td> <td>±1,20</td> </tr> <tr> <td></td> <td>MAS DE 400 A 1000 mm</td> <td>±0,30</td> <td>±0,80</td> <td>±2,00</td> </tr> <tr> <td></td> <td>MAS DE 1000 A 2000 mm</td> <td>±0,50</td> <td>±1,20</td> <td>±3,00</td> </tr> </tbody> </table>					LINEAL	GRADO TOLERANCIA	FINO	MEDIO	GRUESO		HASTA 3 mm	±0,05	±0,10	±0,15		MAS DE 3 A 6 mm	±0,05	±0,10	±0,20		MAS DE 6 A 30 mm	±0,10	±0,20	±0,50		MAS DE 30 A 120 mm	±0,15	±0,30	±0,80		MAS DE 120 A 400 mm	±0,20	±0,50	±1,20		MAS DE 400 A 1000 mm	±0,30	±0,80	±2,00		MAS DE 1000 A 2000 mm	±0,50	±1,20	±3,00	<table border="1"> <tr> <td>A4</td> <td>Nombre</td> <td>Fecha</td> </tr> <tr> <td>Dibujado</td> <td>A.J.GONZALEZ</td> <td>Dic-2010</td> </tr> <tr> <td>Modificado</td> <td></td> <td></td> </tr> </table>		A4	Nombre	Fecha	Dibujado	A.J.GONZALEZ	Dic-2010	Modificado					
LINEAL	GRADO TOLERANCIA	FINO	MEDIO	GRUESO																																																						
	HASTA 3 mm	±0,05	±0,10	±0,15																																																						
	MAS DE 3 A 6 mm	±0,05	±0,10	±0,20																																																						
	MAS DE 6 A 30 mm	±0,10	±0,20	±0,50																																																						
	MAS DE 30 A 120 mm	±0,15	±0,30	±0,80																																																						
	MAS DE 120 A 400 mm	±0,20	±0,50	±1,20																																																						
	MAS DE 400 A 1000 mm	±0,30	±0,80	±2,00																																																						
	MAS DE 1000 A 2000 mm	±0,50	±1,20	±3,00																																																						
A4	Nombre	Fecha																																																								
Dibujado	A.J.GONZALEZ	Dic-2010																																																								
Modificado																																																										
<table border="1"> <tr> <td>Escala</td> <td colspan="4">MFP-225-GN_F</td> </tr> <tr> <td>1:25</td> <td colspan="4">Código máquina: CODIGO</td> </tr> </table>					Escala	MFP-225-GN_F				1:25	Código máquina: CODIGO																																															
Escala	MFP-225-GN_F																																																									
1:25	Código máquina: CODIGO																																																									

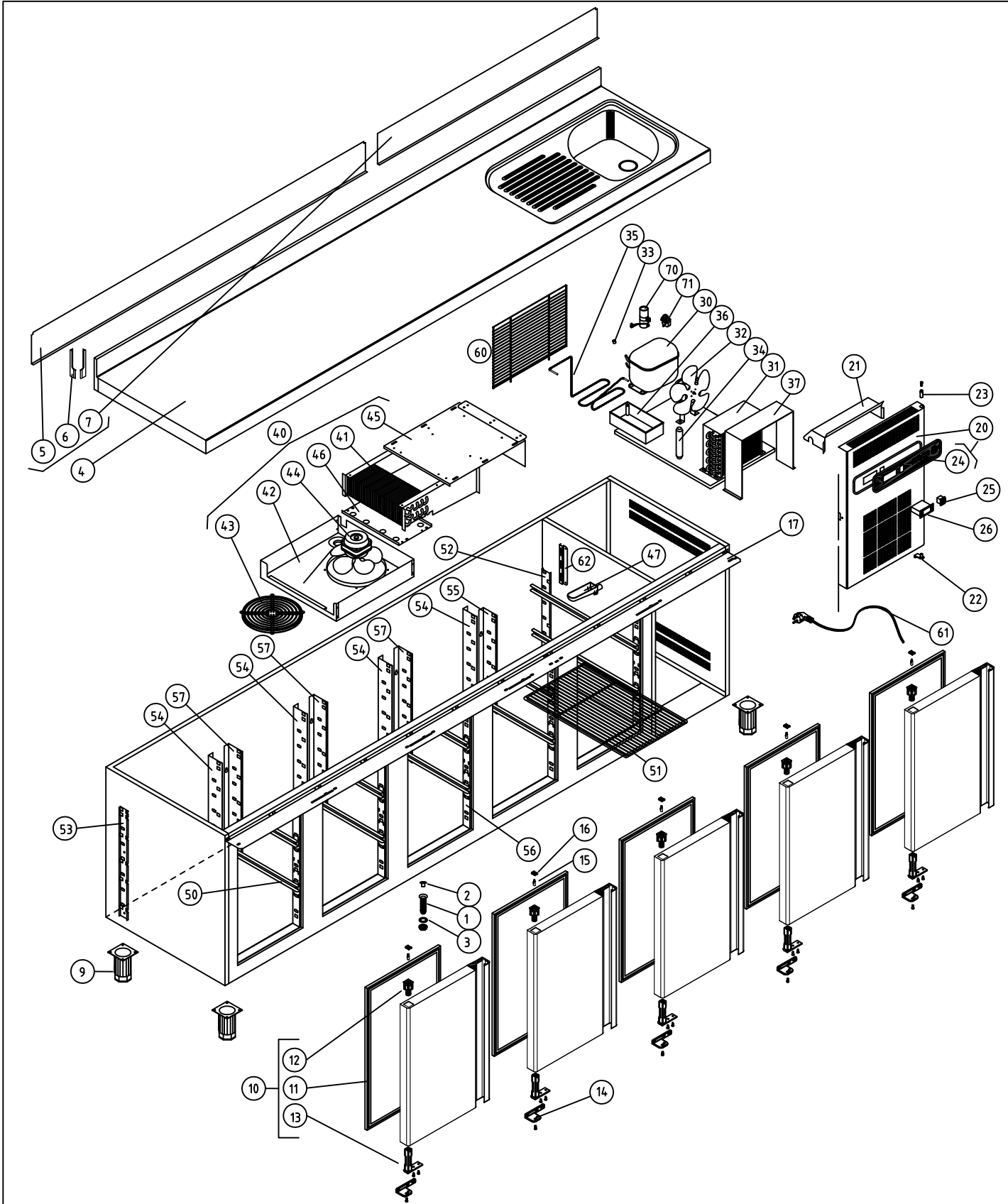

MFP-270-GN_F COD. PIEZA: 148314030000

COTAS SIN TOLERANCIA DIN 7168-f Material: MATERIAL ESPESOR

Acabado: ACABADO SUSTITUYE A:

SUSTITUIDO POR:

ANGULAR	GRADO TOLERANCIA	FINO	MEDIO	GRUESO
	HASTA 10 mm		±1°	±1° 30'
MAS DE 10 A 50 mm		±30'	±50'	
MAS DE 50 A 120 mm		±20'	±25'	
MAS DE 120 A 400 mm		±10'	±15'	
MAS DE 400 mm		±5'	±10'	

LINEAL	GRADO TOLERANCIA	FINO	MEDIO	GRUESO
	HASTA 3 mm		±0,05	±0,10
MAS DE 3 A 6 mm		±0,05	±0,10	±0,20
MAS DE 6 A 30 mm		±0,10	±0,20	±0,50
MAS DE 30 A 120 mm		±0,15	±0,30	±0,80
MAS DE 120 A 400 mm		±0,20	±0,50	±1,20
MAS DE 400 A 1000 mm		±0,30	±0,80	±2,00
MAS DE 1000 A 2000 mm		±0,50	±1,20	±3,00

COMUN A	MODELO	Ud.	MODELO	Ud.	MODELO	Ud.	MODELO	Ud.	MODELO	Ud.
	MFP-270-F	1								

A4	Nombre	Fecha
Dibujado	A.J.GONZALEZ	Dic-2010
Modificado		



Escala	1:25	MFP-270-GN_F	Código máquina: CODIGO
--------	------	--------------	---------------------------

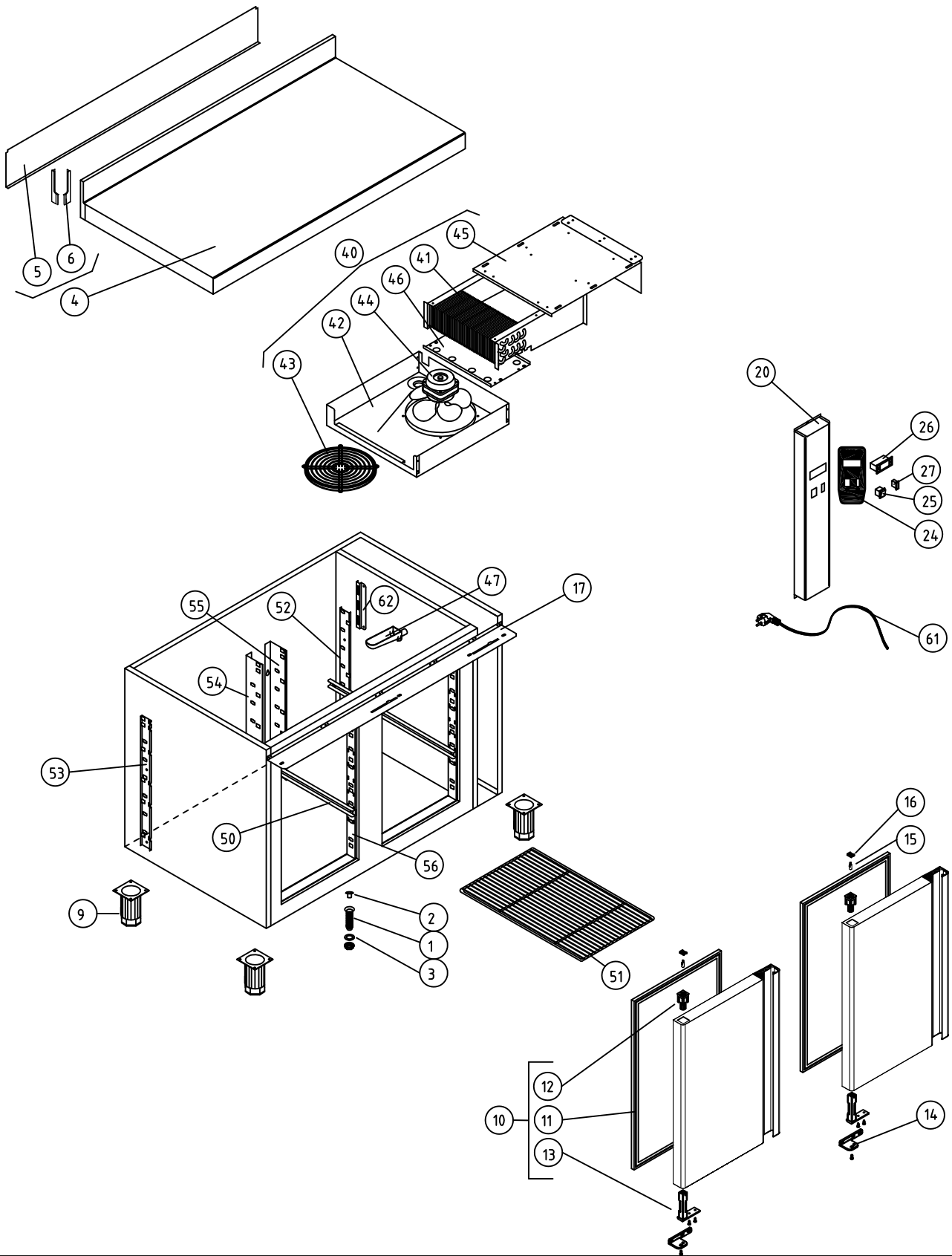

M1 MESAS FRÍAS

COD. PIEZA: 148311001000

COTAS SIN TOLERANCIA DIN 7168-f

Material: MATERIAL ESPESOR

SUSTITUYE A:

Acabado: ACABADO

SUSTITUIDO POR:

ANGULAR	GRADO TOLERANCIA	FINO	MEDIO	GRUESO
	HASTA 10 mm		±1°	±1° 30'
	MÁS DE 10 A 50 mm		±30'	±50'
	MÁS DE 50 A 120 mm		±20'	±25'
	MÁS DE 120 A 400 mm		±10'	±15'
MÁS DE 400 mm		±5'	±10'	

COMUN A	MODELO	Ud.	MODELO	Ud.	MODELO	Ud.	MODELO	Ud.	MODELO	Ud.
	MFP-102-R	1								

LINEAL	GRADO TOLERANCIA	FINO	MEDIO	GRUESO
	HASTA 3 mm	±0,05	±0,10	±0,15
	MÁS DE 3 A 6 mm	±0,05	±0,10	±0,20
	MÁS DE 6 A 30 mm	±0,10	±0,20	±0,50
	MÁS DE 30 A 120 mm	±0,15	±0,30	±0,80
MÁS DE 120 A 400 mm	±0,20	±0,50	±1,20	
MÁS DE 400 A 1000 mm	±0,30	±0,80	±2,00	
MÁS DE 1000 A 2000 mm	±0,50	±1,20	±3,00	

A4	Nombre	Fecha
Dibujado	A.J.GONZALEZ	Dic-2010
Modificado		
Escala	1:22	

FAGOR 

F A G O R I

RECAMBIOS MFP-102-GN_R

Código máquina:
CODIGO

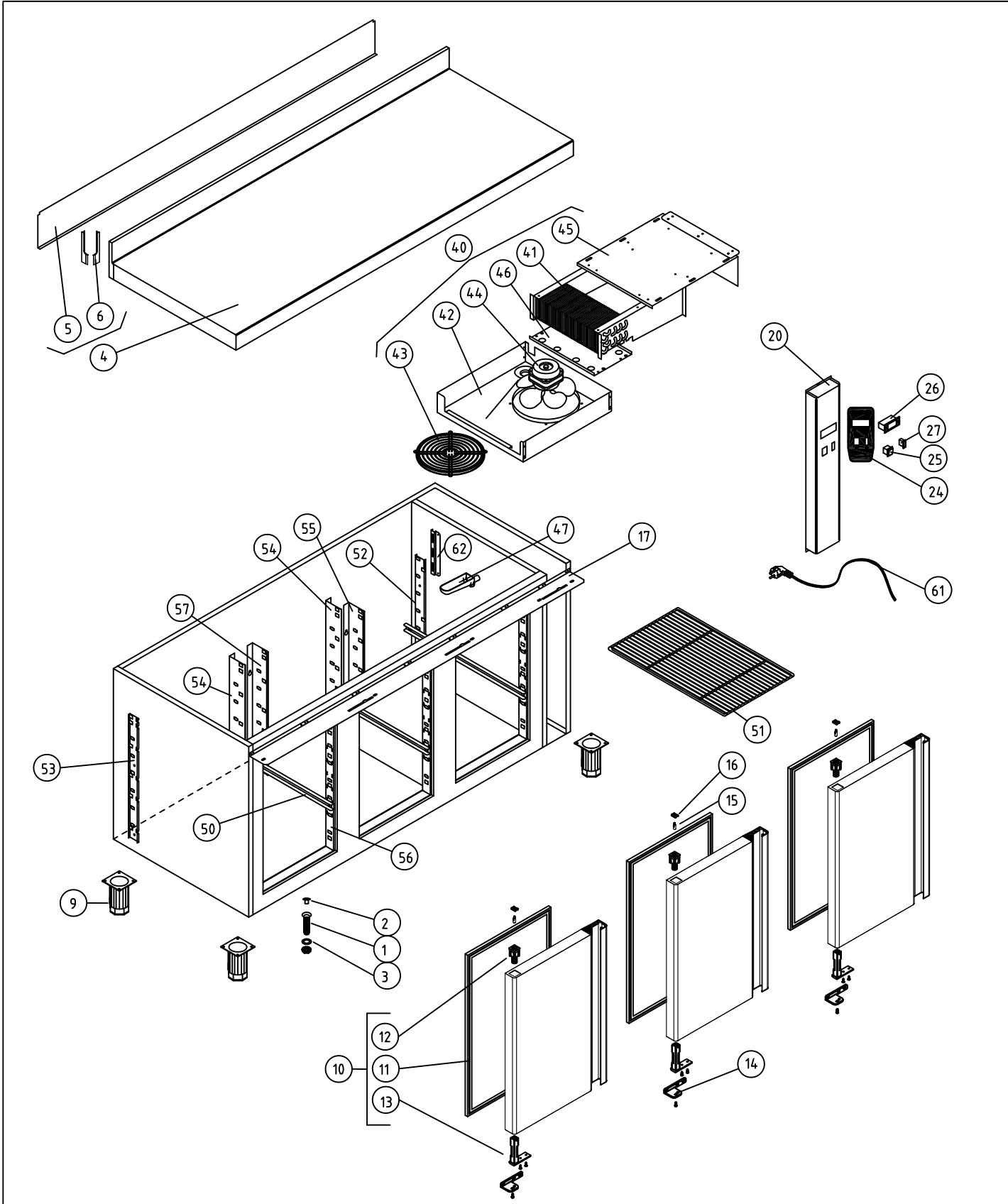

M1 MESAS FRÍAS				COD. PIEZA: 148312001000								
COTAS SIN TOLERANCIA DIN 7168-f				Material: MATERIAL ESPESOR								
Material: MATERIAL ESPESOR				SUSTITUYE A:								
Acabado: ACABADO				SUSTITUIDO POR:								
ANGULAR	GRADO TOLERANCIA	FINO	MEDIO	GRUESO								
	HASTA 10 mm		±1°	±1° 30'								
	MÁS DE 10 A 50 mm		±30'	±50'								
	MÁS DE 50 A 120 mm		±20'	±25'								
COMUN A	MÁS DE 120 A 400 mm		±10'	±15'	MODELO	Ud.	MODELO	Ud.	MODELO	Ud.	MODELO	Ud.
	MÁS DE 400 mm		±5'	±10'	MFP-147-R	1						
LINEAL	GRADO TOLERANCIA	FINO	MEDIO	GRUESO	A4		Nombre		Fecha			
	HASTA 3 mm	±0,05	±0,10	±0,15	Dibujado		A.J.GONZALEZ		Dic-2010			
	MÁS DE 3 A 6 mm	±0,05	±0,10	±0,20	Modificado							
	MÁS DE 6 A 30 mm	±0,10	±0,20	±0,50	Escala		1:22		RECAMBIOS MFP-147-GN_R		Código máquina:	
	MÁS DE 30 A 120 mm	±0,15	±0,30	±0,80							CODIGO	
	MÁS DE 120 A 400 mm	±0,20	±0,50	±1,20								
MÁS DE 400 A 1000 mm	±0,30	±0,80	±2,00									
MÁS DE 1000 A 2000 mm	±0,50	±1,20	±3,00									

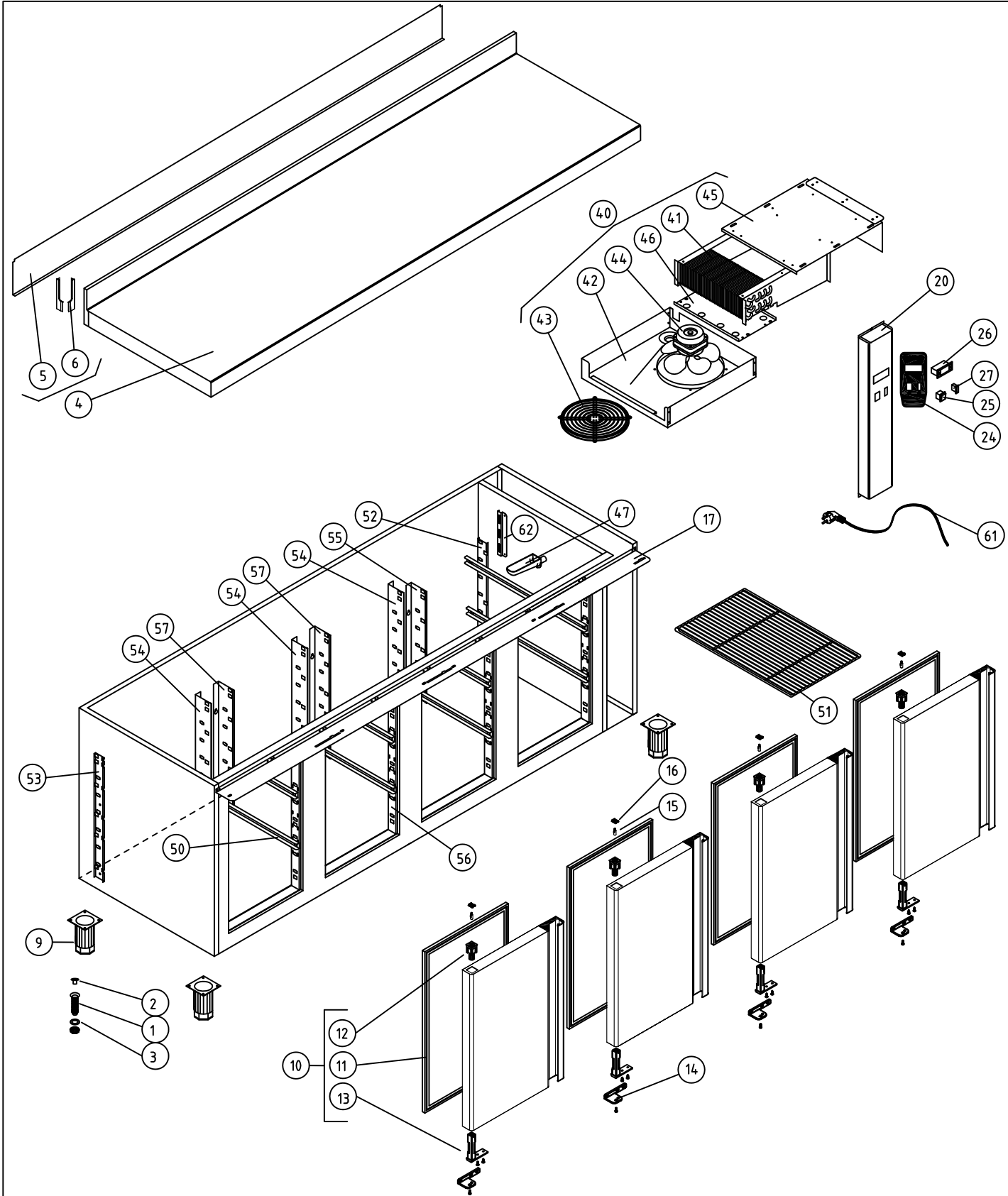

M1 MESAS FRÍAS COD. PIEZA: 148313001000

COTAS SIN TOLERANCIA DIN 7168-f Material: MATERIAL ESPESOR

Acabado: ACABADO SUSTITUYE A:

SUSTITUIDO POR:

ANGULAR	GRADO TOLERANCIA	FINO	MEDIO	GRUESO
	HASTA 10 mm		±1°	±1° 30'
MÁS DE 10 A 50 mm		±30'	±50'	
MÁS DE 50 A 120 mm		±20'	±25'	
MÁS DE 120 A 400 mm		±10'	±15'	
MÁS DE 400 mm		±5'	±10'	

LINEAL	GRADO TOLERANCIA	FINO	MEDIO	GRUESO
	HASTA 3 mm		±0,05	±0,10
MÁS DE 3 A 6 mm		±0,05	±0,10	±0,20
MÁS DE 6 A 30 mm		±0,10	±0,20	±0,50
MÁS DE 30 A 120 mm		±0,15	±0,30	±0,80
MÁS DE 120 A 400 mm		±0,20	±0,50	±1,20
MÁS DE 400 A 1000 mm		±0,30	±0,80	±2,00
MÁS DE 1000 A 2000 mm		±0,50	±1,20	±3,00

COMUN A	MODELO	Ud.	MODELO	Ud.	MODELO	Ud.	MODELO	Ud.	MODELO
	MFP-192-R	1							

A4	Nombre	Fecha	FAGOR F A G O F R I
Dibujado	A.J.GONZALEZ	Dic-2010	
Modificado			

Escala	RECAMBIOS MFP-192-GN_R	Código máquina: CODIGO
1:22		

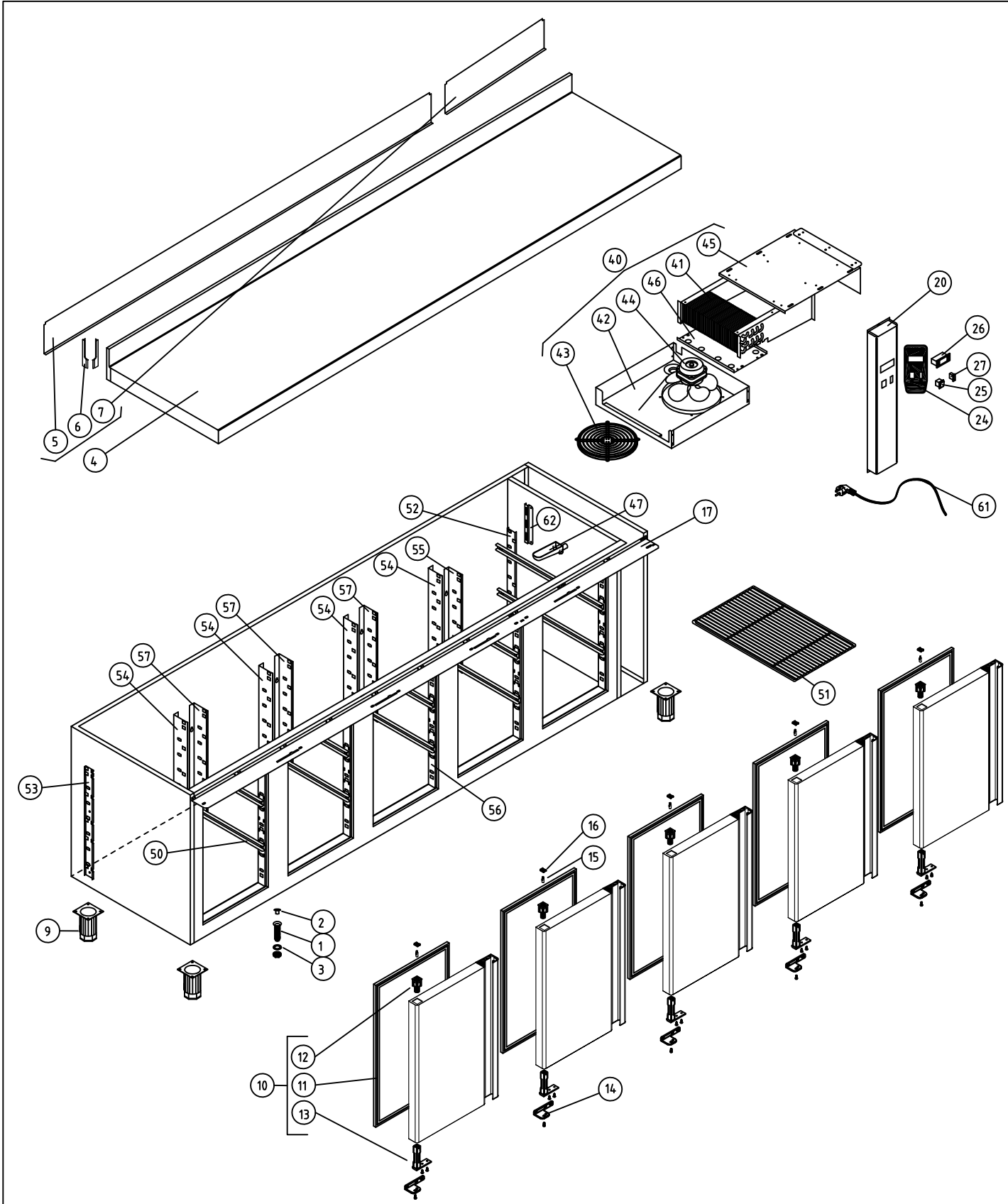

COTAS SIN TOLERANCIA DIN 7168-f				Material: MATERIAL ESPESOR				COD. PIEZA: X			
GRADO TOLERANCIA				Acabado: ACABADO				SUSTITUYE A:			
HASTA 10 mm								SUSTITUIDO POR:			
ANGULAR	FINO	MEDIO	GRUESO	MODELO	Ud.	MODELO	Ud.	MODELO	Ud.	MODELO	Ud.
	±1°	±1° 30'		MFP-237-R	1						
	±30'	±50'									
	±20'	±25'									
LINEAL	FINO	MEDIO	GRUESO	A4		Nombre		Fecha		FAGOR  F A G O F R I	
	±0,05	±0,10	±0,15	Dibujado		A.J.GONZALEZ		Dic-2010			
	±0,10	±0,20	±0,50	Modificado							
	±0,15	±0,30	±0,80	Escala		1:25		MFP-237-GN_R			
HASTA 3 mm								Código máquina:			
MAS DE 3 A 6 mm								CODIGO			
MAS DE 6 A 30 mm											
MAS DE 30 A 120 mm											
MAS DE 120 A 400 mm											
MAS DE 400 A 1000 mm											
MAS DE 1000 A 2000 mm											

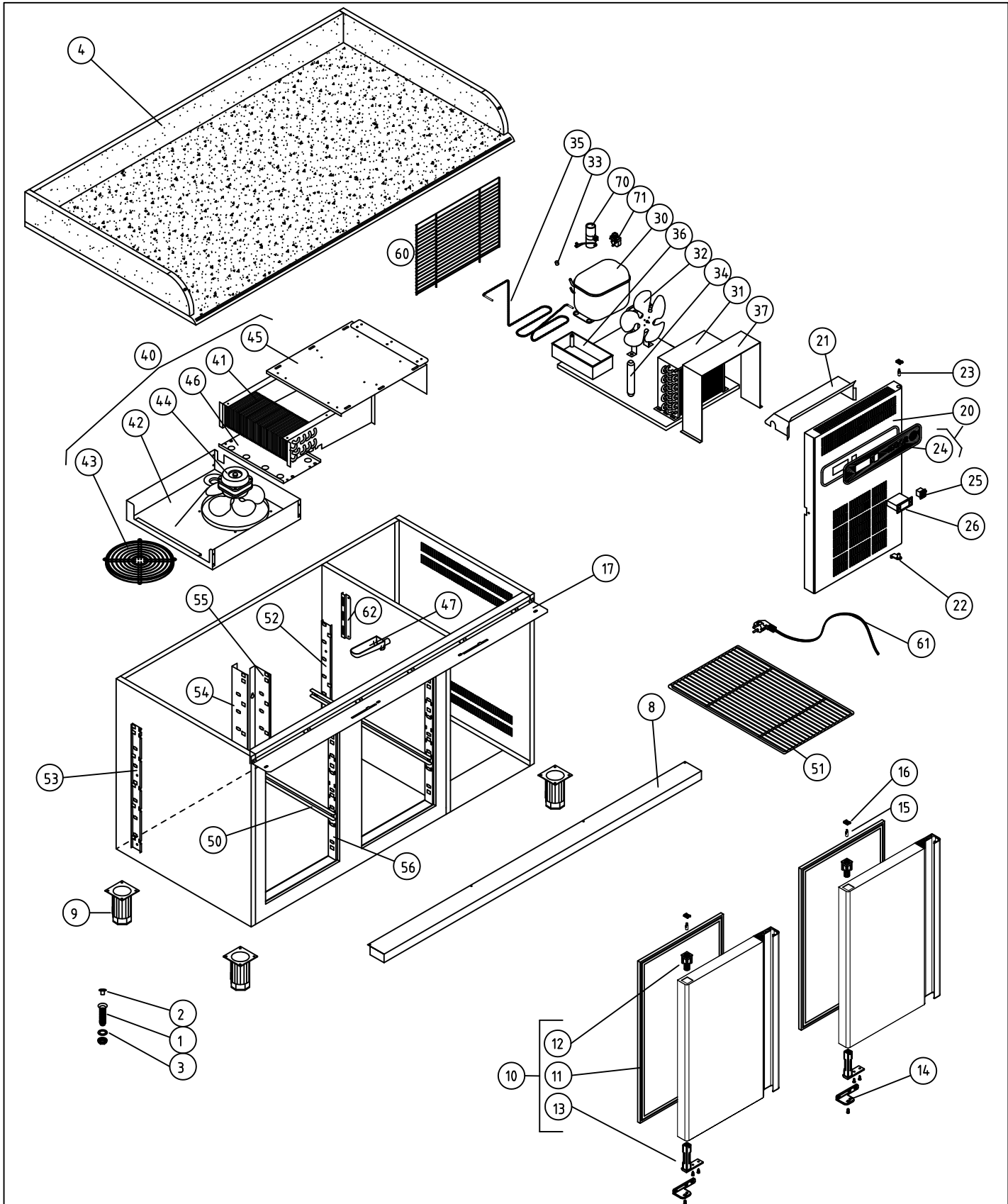

M1 MESAS FRÍAS					COD. PIEZA: 148311100000												
COTAS SIN TOLERANCIA DIN 7168-f					Material: .												
SUSTITUYE A:					SUSTITUIDO POR:												
ANGULAR	GRADO TOLERANCIA	FINO	MEDIO	GRUESO	COMUN A	MODELO	Ud.	MODELO	Ud.	MODELO	Ud.	MODELO	Ud.	MODELO	Ud.		
	HASTA 10 mm		±1°	±1° 30'		MFPG-135-GN	1										
	MAS DE 10 A 50 mm		±30'	±50'													
	MAS DE 50 A 120 mm		±20'	±25'													
LINEAL	MAS DE 120 A 400 mm		±10'	±15'													
	MAS DE 400 mm		±5'	±10'													
	GRADO TOLERANCIA	FINO	MEDIO	GRUESO	A4	Nombre	Fecha										
	HASTA 3 mm	±0,05	±0,10	±0,15	Dibujado	A.J.GONZALEZ	Dic-2010										
MAS DE 3 A 6 mm	±0,05	±0,10	±0,20	Modificado	.	.											
MAS DE 6 A 30 mm	±0,10	±0,20	±0,50	Escala	1:22					RECAMBIOS MFPG-135-GN		Código máquina:					
MAS DE 30 A 120 mm	±0,15	±0,30	±0,80														
MAS DE 120 A 400 mm	±0,20	±0,50	±1,20														
MAS DE 400 A 1000 mm	±0,30	±0,80	±2,00														
MAS DE 1000 A 2000 mm	±0,50	±1,20	±3,00														

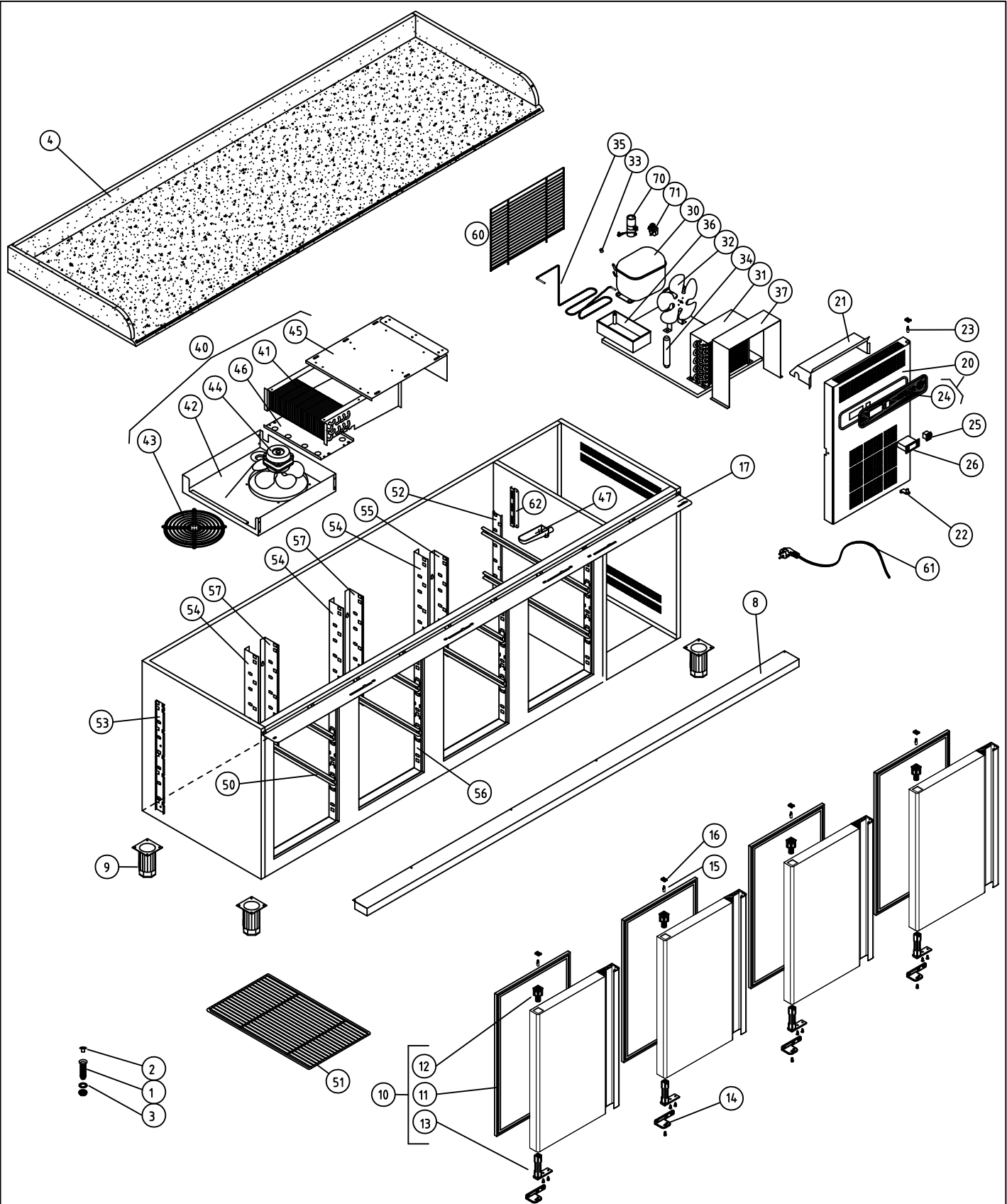

COD. PIEZA: 14831310000

COTAS SIN TOLERANCIA DIN 7168-f

ANGULAR	GRADO TOLERANCIA	FINO	MEDIO	GRUESO
	HASTA 10 mm		±1°	
MAS DE 10 A 50 mm		±30'		±50'
MAS DE 50 A 120 mm		±20'		±25'
MAS DE 120 A 400 mm		±10'		±15'
MAS DE 400 mm		±5'		±10'

LINEAL	GRADO TOLERANCIA	FINO	MEDIO	GRUESO
	HASTA 3 mm	±0,05	±0,10	±0,15
	MAS DE 3 A 6 mm	±0,05	±0,10	±0,20
	MAS DE 6 A 30 mm	±0,10	±0,20	±0,50
	MAS DE 30 A 120 mm	±0,15	±0,30	±0,80
MAS DE 120 A 400 mm	±0,20	±0,50	±1,20	
MAS DE 400 A 1000 mm	±0,30	±0,80	±2,00	
MAS DE 1000 A 2000 mm	±0,50	±1,20	±3,00	

Material:									
Acabado:									
COMUN A	MODELO	Ud.	MODELO	Ud.	MODELO	Ud.	MODELO	Ud.	MODELO
	MFPG-225	1							
A4	Nombre			Fecha					
Dibujado	A.J.GONZALEZ		Dic-2010						
Modificado									
Escala	1:25		MFPG-225-GN						

SUSTITUYE A:

SUSTITUIDO POR:

FAGOR 

F A G O F R I

Código máquina:
CODIGO