

RECAMBIOS
MFP-192-GN_R

13/06/2008





F A G O R I

COD. 148313001000

N.	CODIGO	DENOMINACION	CANTIDAD
1	6003010326	DESAG COMPL 3/4 GRIS+TUERCA	1
2	6003010262	TAPON DESAGÜE DE 3/4 CIEGO	1
3	6003010327	JUNTA GOMA DESAGÜE 3/4	1
4	M181010479	ENCIM.MFP-192-GN_R	1
5	M109170857	PROTECT.TRASER.MFP192	1
6	6033090086	JUEGO TAPETAS ENCIM.ZAMAK	1
7	M109050562	SOPOR.SUP.PUERTAS MFP-192 R	1
8	6007050017	PATA REGULAB ARM GASTRO	4
9	6025050010	TORN 4.8x25 ZINC DIN 7981	16
10	M169010093	PUERTA MFP/MFN-2006 FAGOR	4
11	6045010119	BURLETE MFP 385x580 MFP2006	4
12	6003010136	CAJA ALOJAMIENTO MUELLE GRIS	4
13	6033010100	BIS.TRSD DOBL MUELLE DV-2608	4
14	M169090003	JGO.BISAG.APERT.IZDA MSP COMPLETO	4
15	M177010070	CUADRO MANDOS MSP-R	1
17	6021130010	PILOTO RECTAN. AMBAR LUM FAGOR	1
18	6033090064	EJE30x10VARIL INOX ROSC.INT M6	5
20	6023010418	PEG.CUADRO REMOTO 105x220	1
31	6021130001	INT.BIP.AMB.O/I CONTAC.REFORZ.	1
32	6021350018	TERMOS REFRI CAREL PYCO1RN515	1
33	6021410034	INST.ELE.MESA REMOTAS REFRIG.	1
34	M171010080	UD.EVAPORAT.MFP-192-R	1
35	6029010088	BAT.6T3R330A4SMFP06 C/TUB PIN	1
36	M109050033	PROT SONDA 175x49	1
38	M109170831	BASE PATAS MFP NUEVA	1
39	6003010033	DESA.1/2 PULG.CUELL CORT+TUERC	1
40	6003050037	GAVETA TF GASTRO 2006	1
41	6027010003	PARRIL. GN1/1 530x325	4
42	M171010070	GAVET+REJILL+VENTILAD MFP-2006	1
43	6021050001	VENTIL.EVAPOR.5W ARO/TIRO FORZ	1
44	6003010035	REJILLA PROTECCION VENTILADOR	1

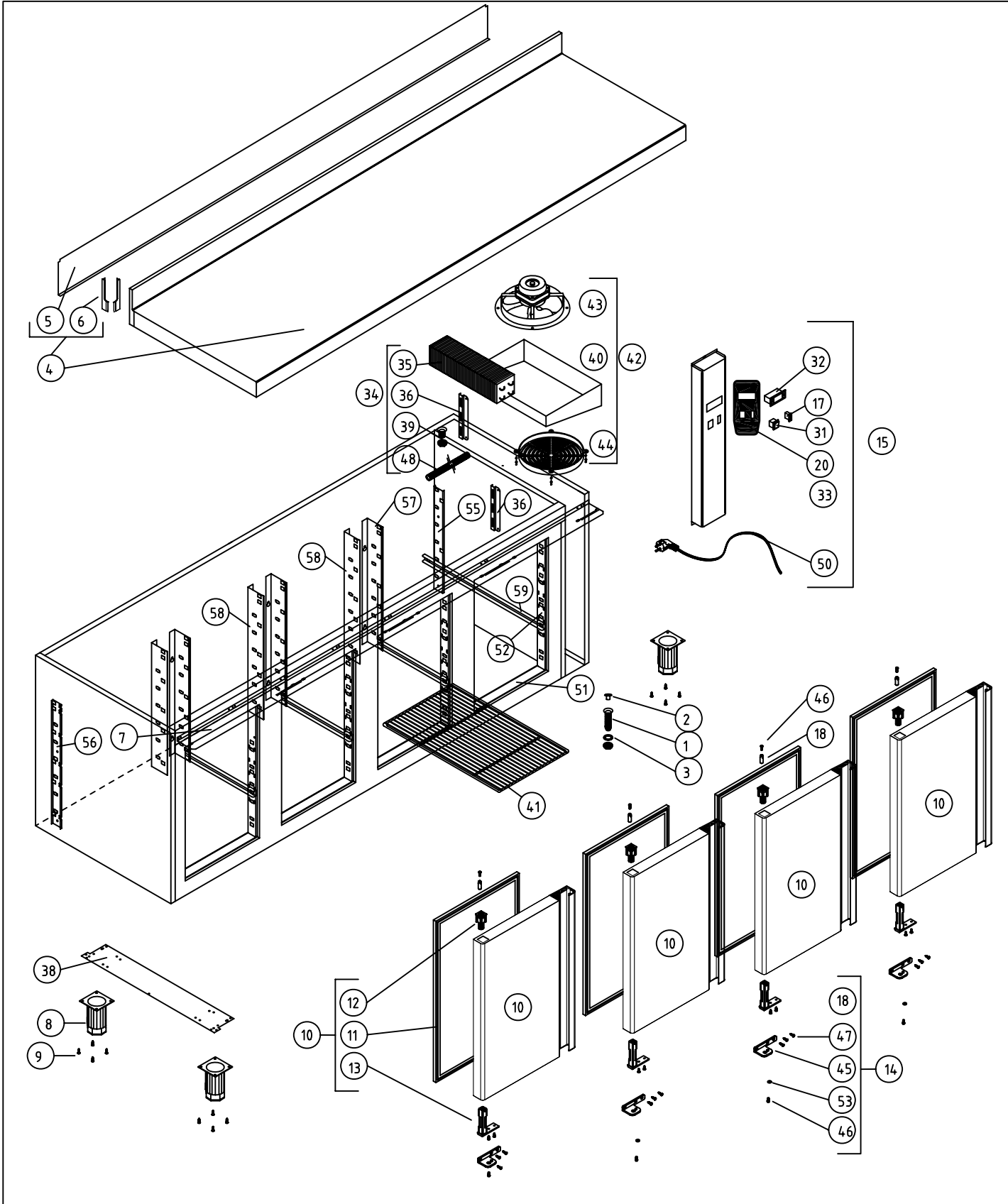
45	6033010098	SOP.BISAG.DV2607 INF IZQ.	4
46	6025090027	TORN M6X10 INOX EXAGONAL	9
47	6025050073	TORN.4.8X32 INOX DIN 7982	12
48	6003010417	TUBO DESAG.BUFLEX D.INT=17MM	1
50	6021390006	MANG 3X1X2500 BL. SCHUKO 3T	1
51	6007170097	PERFIL EN U A 336 MM/90°	8
52	M109050277	CREMALL. MARCO MSP-MFP 2006 CAJ.	8
53	6025210009	ARANDELA ALA ANCHA M6 INOX	8
54	6007020002	TUBO CAPILAR2X0,8 MM.INT.	1
55	M109050298	CREMALL.LATER.DCHA.MFP 2006	1
56	M109050299	CREMALL.LATER.IZDA.MFP 2006	1
57	M109050300	CREMALL.RESP.DCHA.MFP 2006	3
58	M109050301	CREMALL.RESP.IZDA. MFP 2006	3
59	6033050015	GUIA SNACK.DT.CONG-MESA GN 562mm	16



M1 MESAS FRÍAS				COD. PIEZA: 148313001000										
COTAS SIN TOLERANCIA DIN 7168-f				Material: MATERIAL ESPESOR										
				SUSTITUYE A:										
				SUSTITUIDO POR:										
ANGULAR	GRADO TOLERANCIA	FINO	MEDIO	GRUESO										
	HASTA 10 mm		±1°	±1° 30'										
	MAS DE 10 A 50 mm		±30'	±50'										
	MAS DE 50 A 120 mm		±20'	±25'										
COMUN A	MAS DE 120 A 400 mm		±10'	±15'	MODELO	Ud.	MODELO	Ud.	MODELO	Ud.	MODELO	Ud.	MODELO	Ud.
	MAS DE 400 mm		±5'	±10'	MFP-192-GN	R								
LINEAL	GRADO TOLERANCIA	FINO	MEDIO	GRUESO										
	HASTA 3 mm		±0,05	±0,10	±0,15									
	MAS DE 3 A 6 mm		±0,05	±0,10	±0,20									
	MAS DE 6 A 30 mm		±0,10	±0,20	±0,50									
	MAS DE 30 A 120 mm		±0,15	±0,30	±0,80									
MAS DE 120 A 400 mm		±0,20	±0,50	±1,20										
MAS DE 400 A 1000 mm		±0,30	±0,80	±2,00										
MAS DE 1000 A 2000 mm		±0,50	±1,20	±3,00										
A4		Nombre		Fecha		 F A G O F R I								
Dibujado		JJVM		12/06/2008										
Modificado														
Escala		1:22		RECAMBIOS MFP-192-GN_R				Código máquina: CODIGO						